

Relay

BR

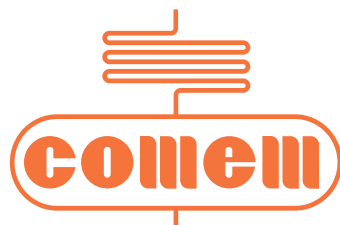

Index

Buchholz relay

General information	2
Overall dimensions according to EN 50216-2 and EN 50216-2_A1	6
Gas sampling device	22
Requirement sheet	23

Gas relay

General information	24
Overall dimensions	26
Requirement sheet	29

Flow relay

General information	30
Overall dimensions	32
Requirement sheet	37

Buchholz relay

Transformer outages have a considerable economic impact on the operation of a power supply network. Therefore it is the aim to ensure an accurate assessment of the transformer condition.

Partial discharges, leakage currents, hot spots and arcing are phenomena that contribute to degradation of oil insulating performances by generating dangerous gas flow inside the transformer tank.

BR

Internal gas accumulation and oil flow are monitored and kept under control by the Buchholz relay.



Thanks to COMEM's proven expertise, we have developed a reliable Buchholz relay that promptly provide information about internal malfunctioning giving the possibility to eventually stop the system prior its destruction.

The Buchholz relay is sited in the pipework between the transformer and its conservator and it is filled with oil during normal transformer operation.

When gas is generated in the transformer it rises towards the conservator and collects in the upper chamber of the relay. The oil level drops and the top float triggers alarm switch. Gas shall not freely pass from the relay body and escape into the pipework before the alarm contact has operated.

Another important functionality of the Buchholz relay is to operate if oil flow from the transformer tank to the oil conservator. In case the oil flow speed exceed the pre-set value, the the flow vent operates and switch the trip contact.

Advantages

- Proven "on the field" reliability
- No false alarms
- Robust reed switch design
- Electrical wiring provided with change-over contacts
- Additional accessories: Gas sampling device.



Buchholz relay

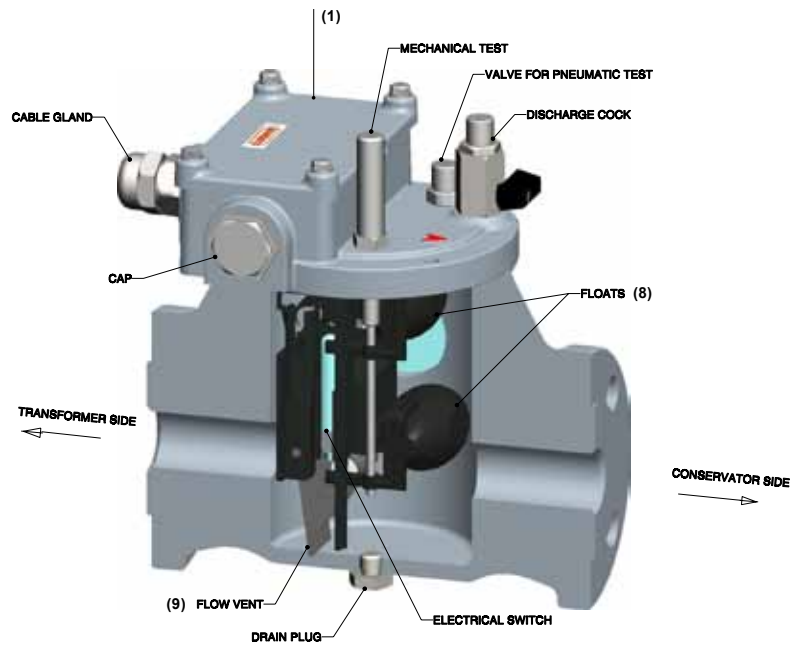

Construction

The housing consists of an aluminum alloy and it is provided with flanges for the connection of the transformer tank pipe and the oil conservator pipe. The terminals of the reed switches are positioned in the terminal box and the perfect sealing is guaranteed by an OR gasket.

The terminal box cover (1) is fixed to the terminal box with 4 unloosable screws.

There are two floats (8) with their associated switches encapsulated in glass bulbs.

The flow vent (9) has two permanent magnets.

Special features

Upon request our Buchholz relays are available with 4M6 vibration class in accordance with EN 50216-2 and EN 50216-2_A1, load stress are in compliance to EN60721-3-4 and to C5. Buchholz relays are available with improved corrosion resistance C5 class according to ISO 12944, suitable for off-shore environment and high salinity area.

Installation guidelines

The following table gives guidelines values:

Transformer Power MVA	Pipe Nominal diameter	Volume of oil Tons
Up to 5MVA	25	Up to 3,5
From 5 up to 20 MVA	50	From 3,6 up to 14
Over 20 MVA*	80	Over 14,1*
Over 20 MVA*	100	Over 14,1*

* In agreement with the transformer design

Tests

Topic	Test description	Standard
Type tests	Checking of the switching capacity of contacts	EN 50216-1
	Vacuum test	EN 50216-2 and EN 50216-2_A1
	Impulse withstand test of electrical circuits	EN 50216-1
	Calibration of gas collection scale on relay window to operate alarm contact if required	EN 50216-2 and EN 50216-2_A1
	Determination of the minimum oil flow to operate the contact and the time for closing	EN 50216-2 and EN 50216-2_A1
	Verification of the absence of reaction of contacts to a flow of oil from conservator to the tank	EN 50216-2 and EN 50216-2_A1
	Pressure withstand test	EN 50216-2 and EN 50216-2_A1
	Verification of the absence of reaction of contacts to magnetic field	EN 50216-2 and EN 50216-2_A1
Routine tests	Vibration test	EN 50216-1
	Short duration power frequency withstand test	EN 50216-1
	Oil leakage test	EN 50216-2 and EN 50216-2_A1
	Operation test	EN 50216-2 and EN 50216-2_A1

Buchholz relay

Overall dimensions according to EN 50216-2 and EN 50216-2_A1

BG25

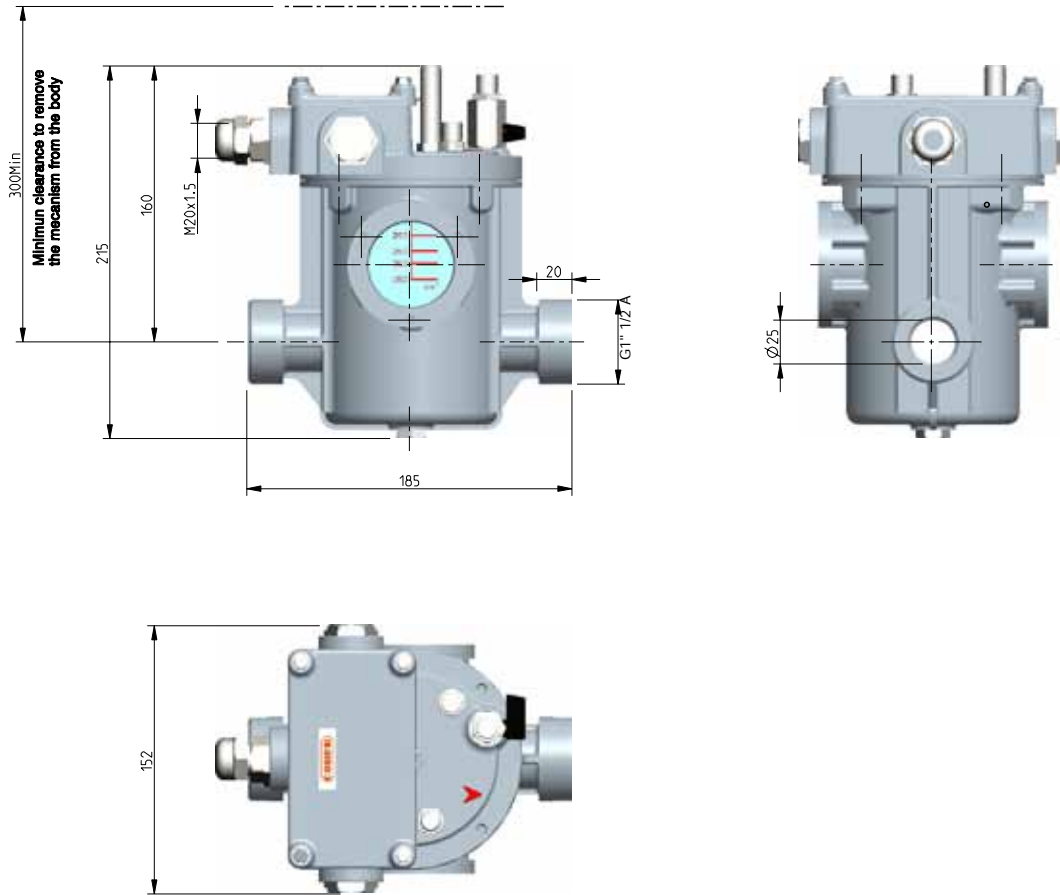

Weight 2.1 Kg

BR25

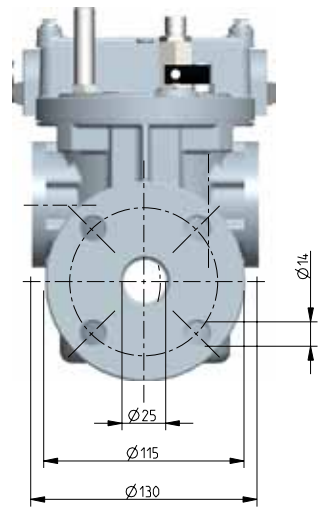
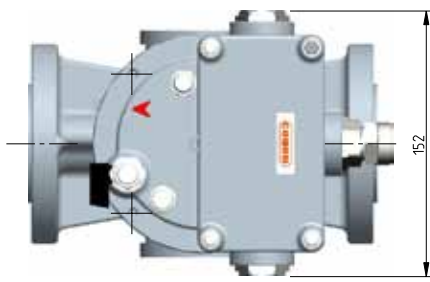
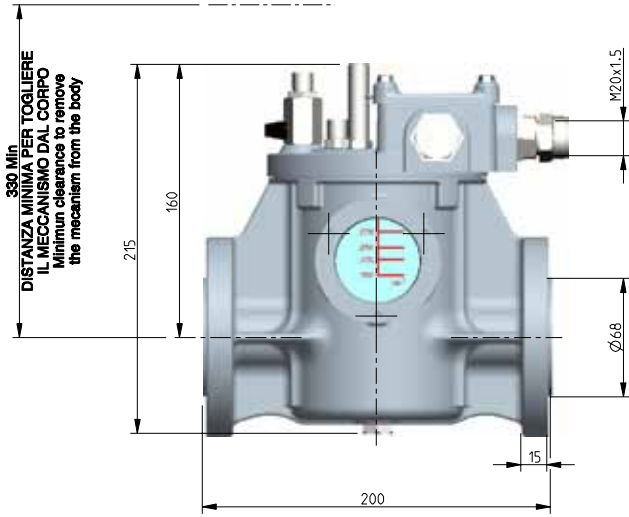

Weight 2.9 Kg

Buchholz relay

Overall dimensions according to EN 50216-2 and EN 50216-2_A1

BR50

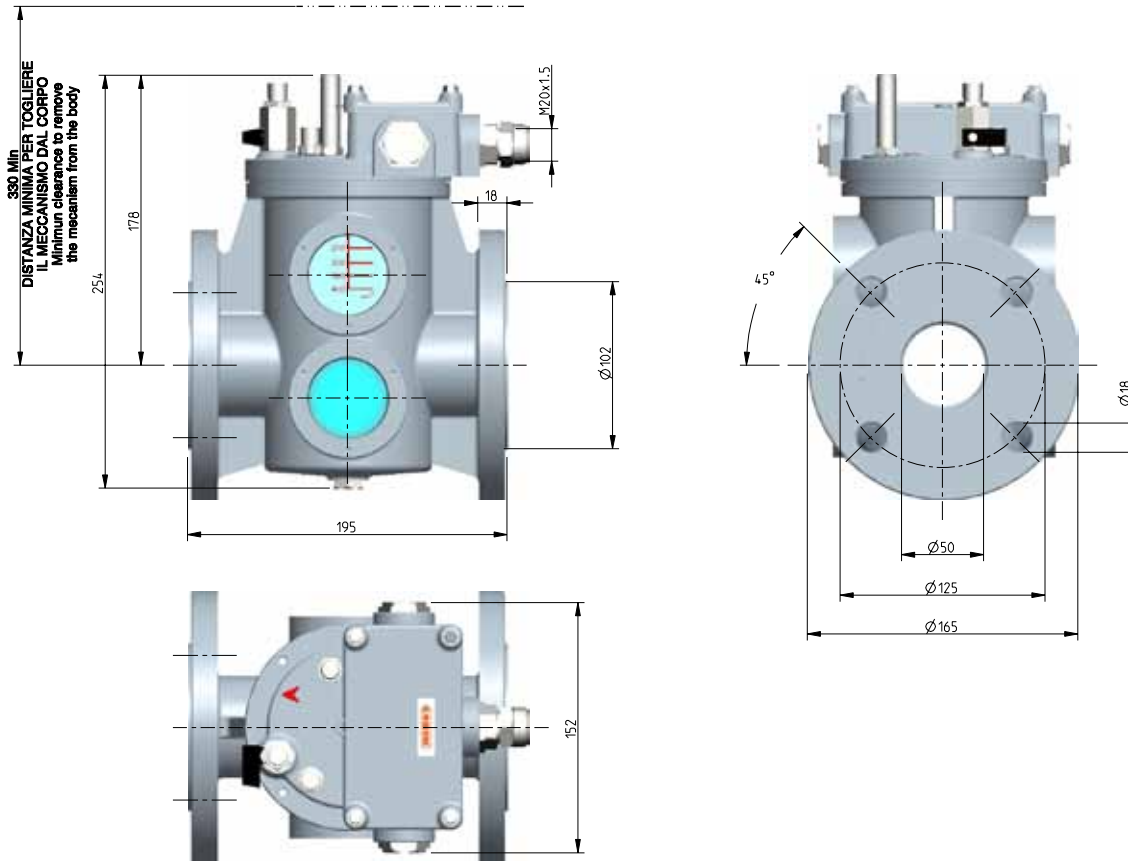

Weight 4.9 Kg

BR80

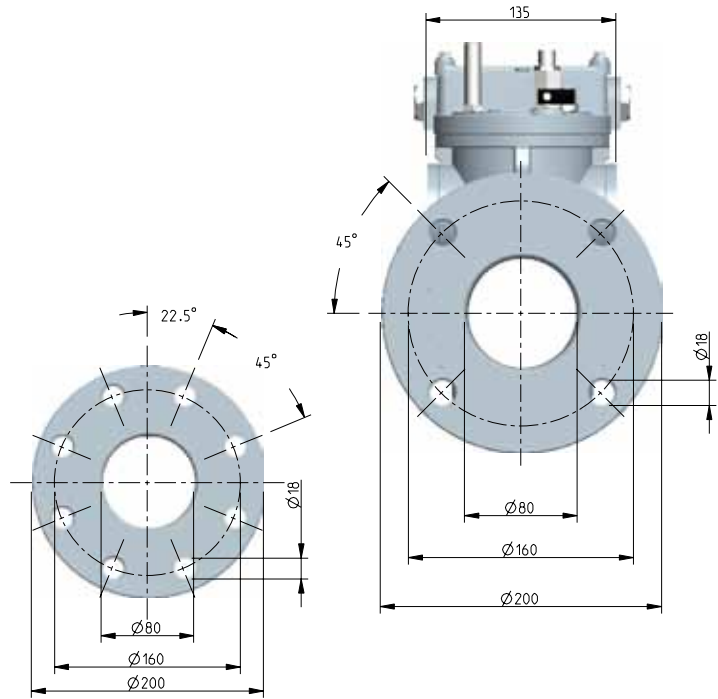
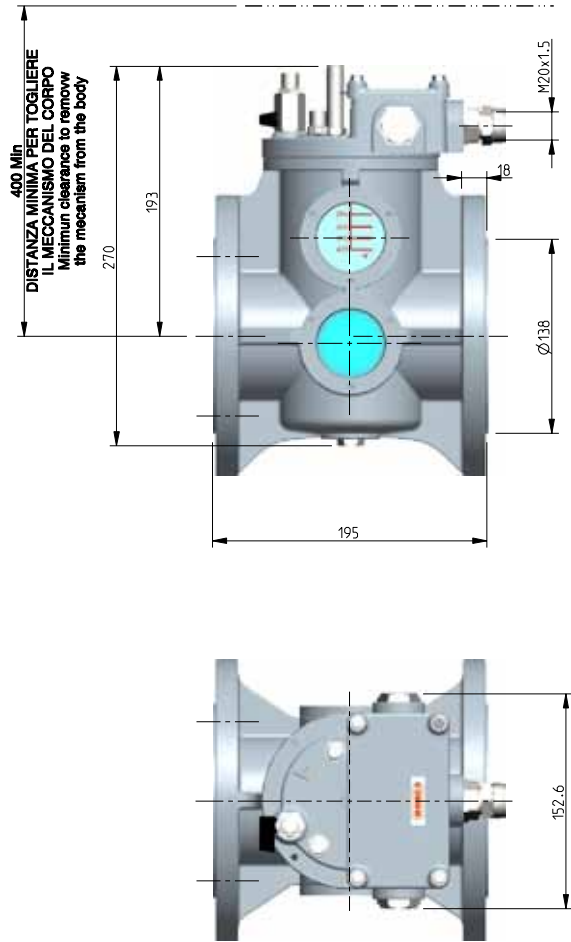

Weight 5.8 Kg

Buchholz relay

Overall dimensions according to EN 50216-2 and EN 50216-2_A1

BS25

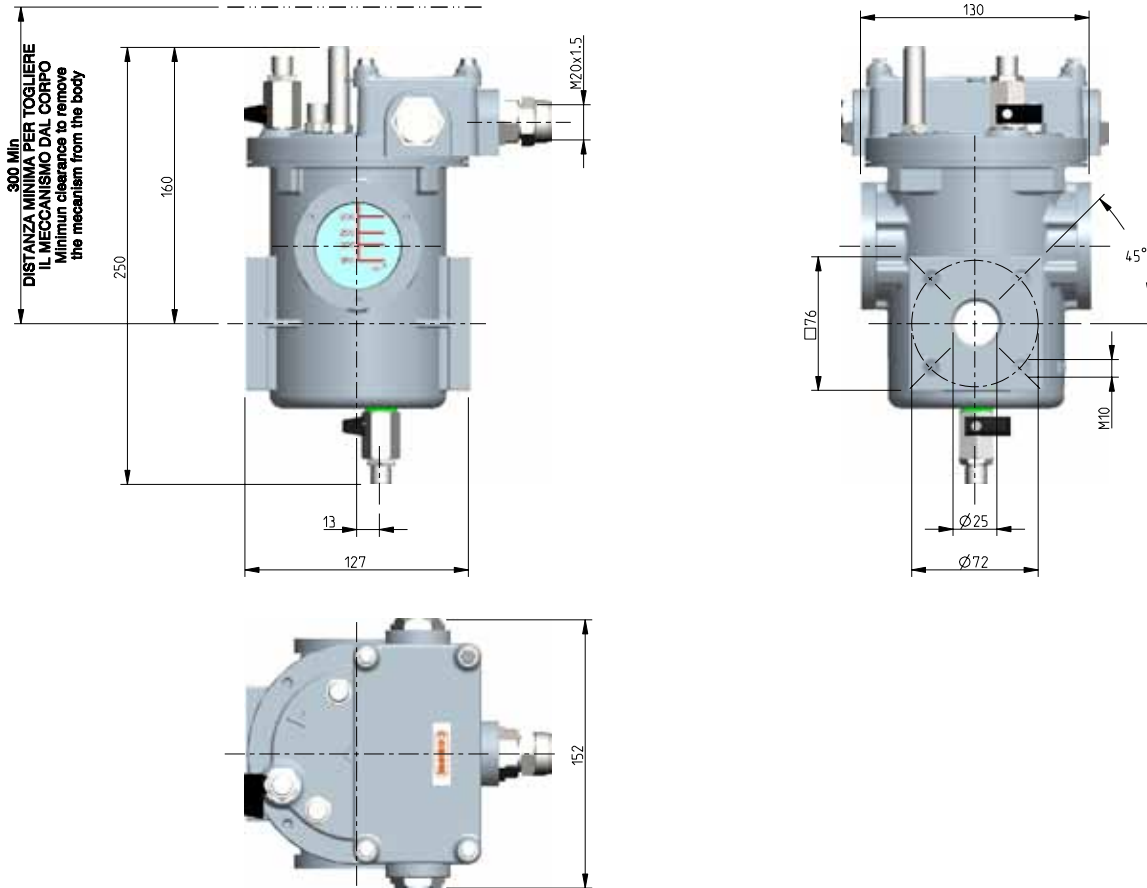

Weight 2.2 Kg

BS50

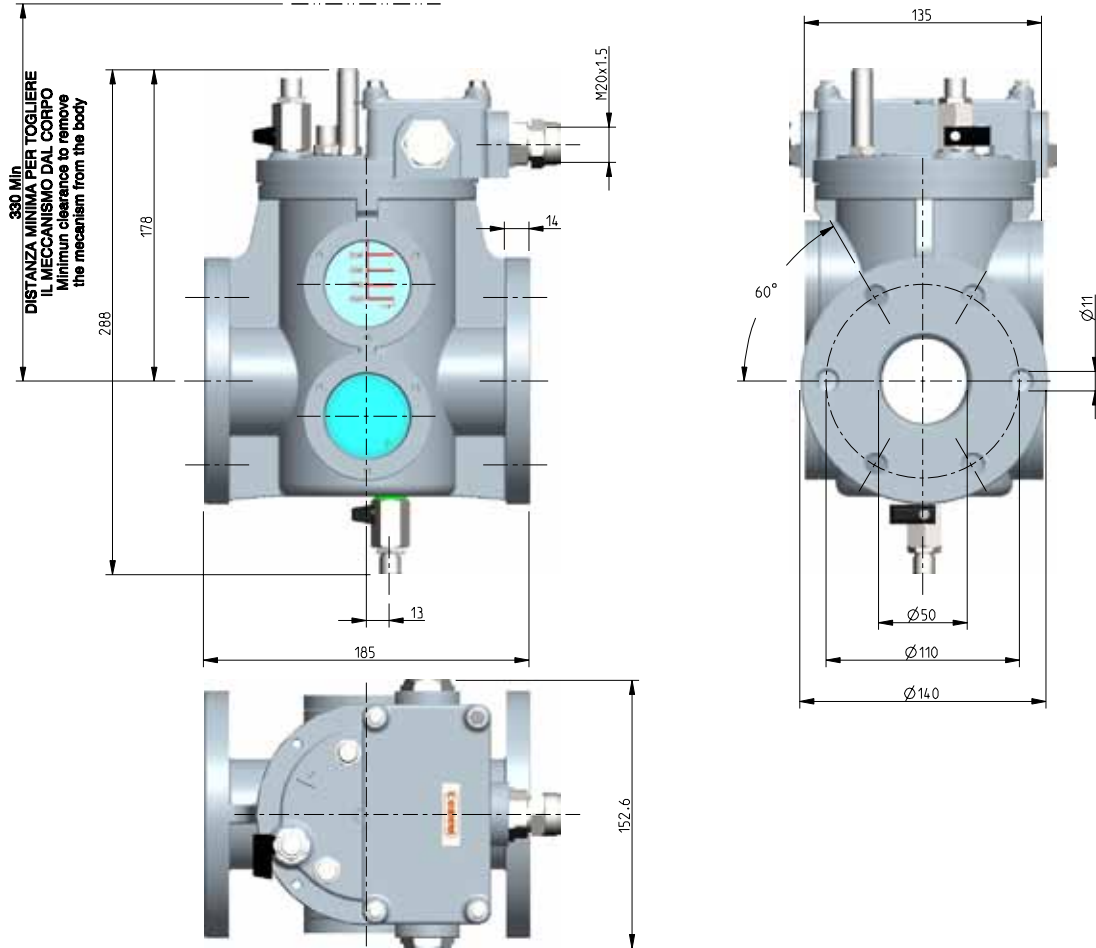

Weight 4.1 Kg

Buchholz relay

Overall dimensions according to EN 50216-2 and EN 50216-2_A1

BS80

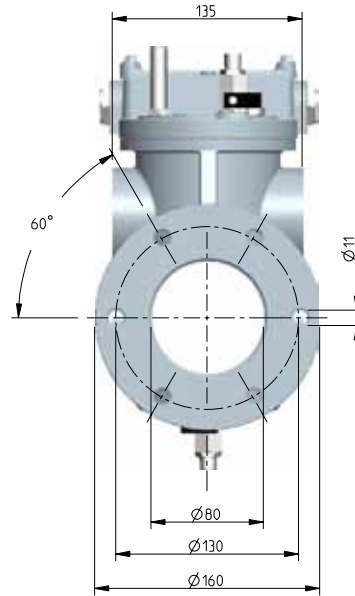
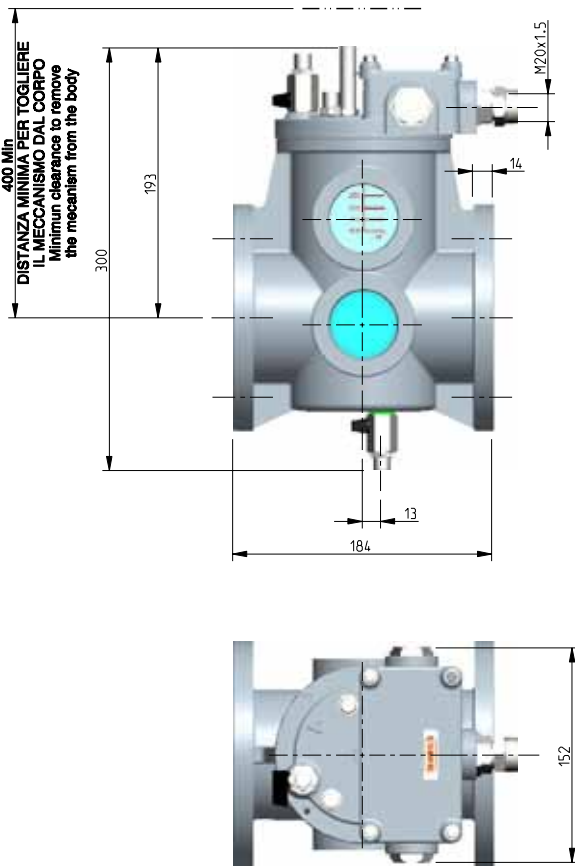

Weight 4.3 Kg

NF25

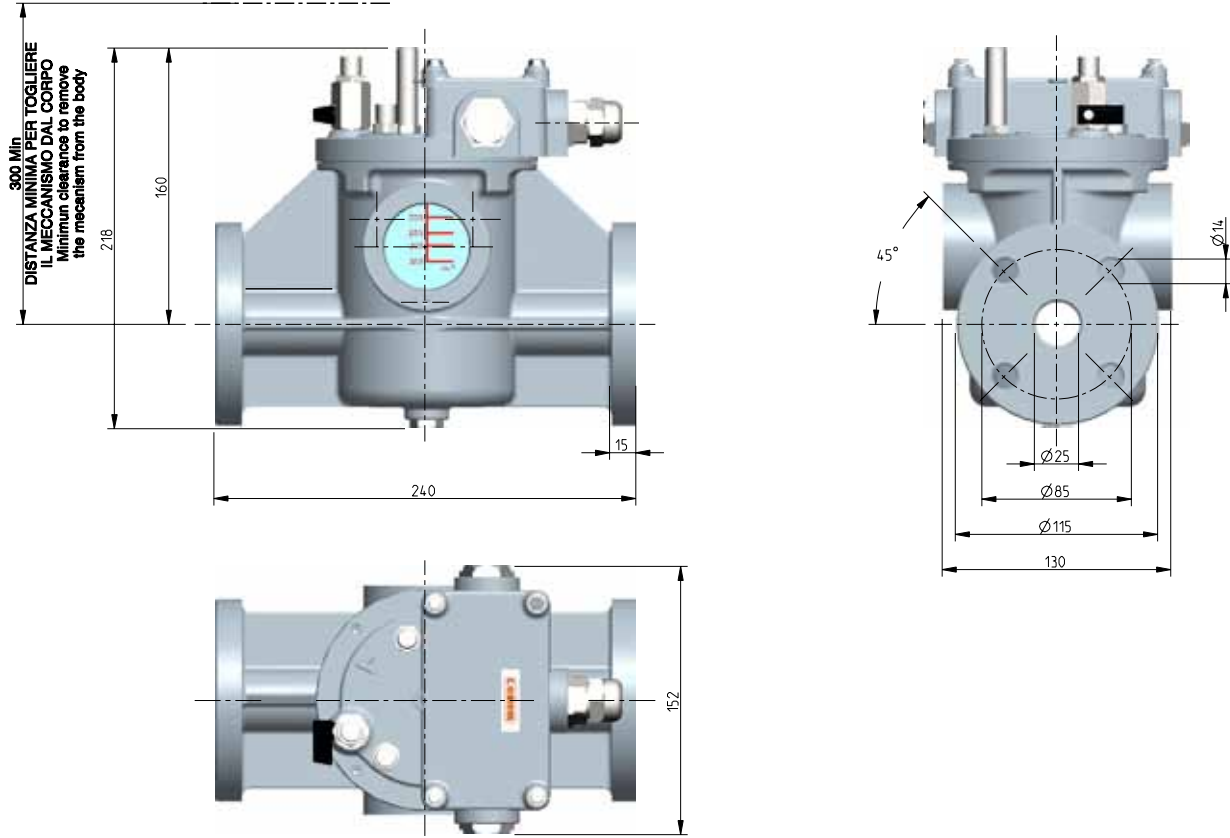

Weight 3.0 Kg

Buchholz relay

Overall dimensions according to EN 50216-2 and EN 50216-2_A1

NF50

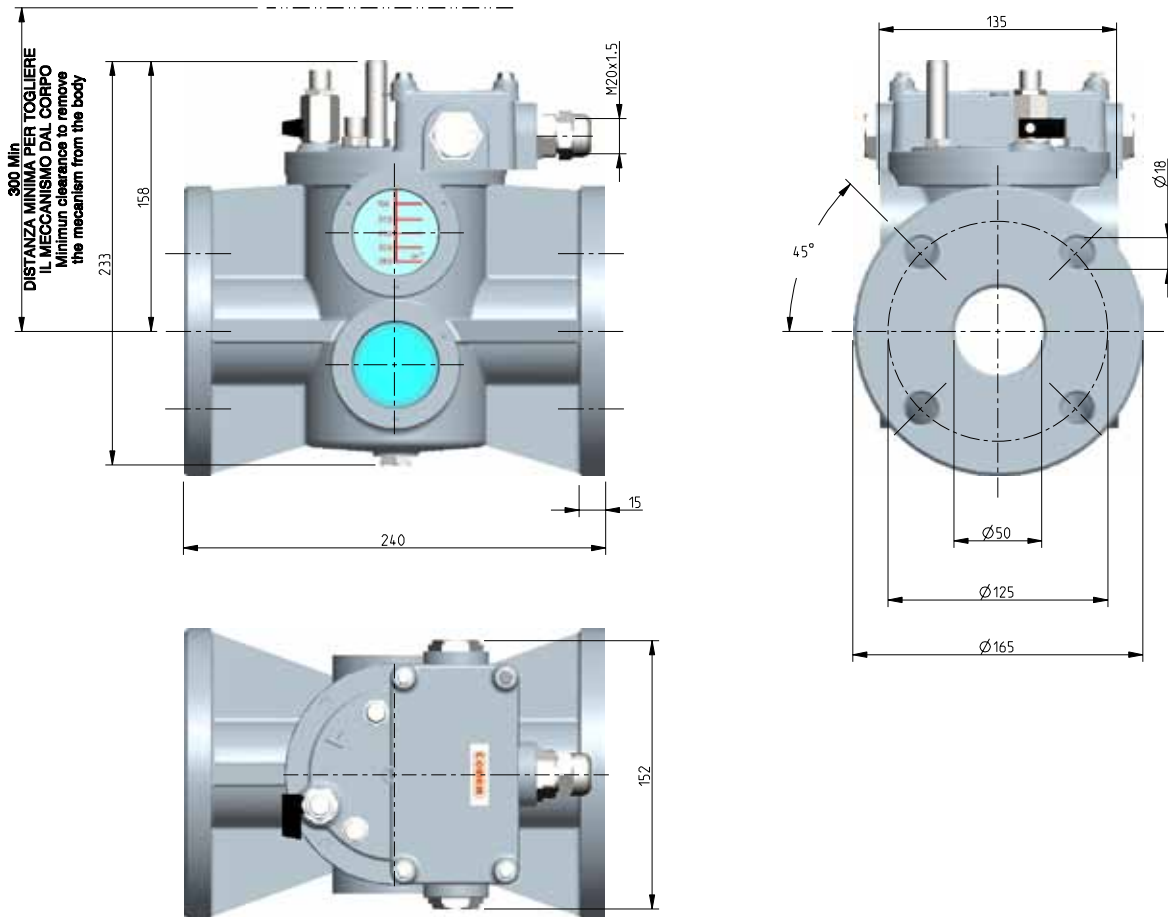

Weight 4.8 Kg

NF80

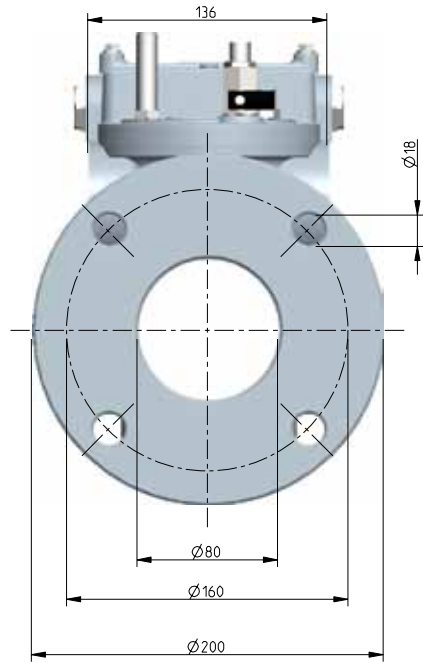
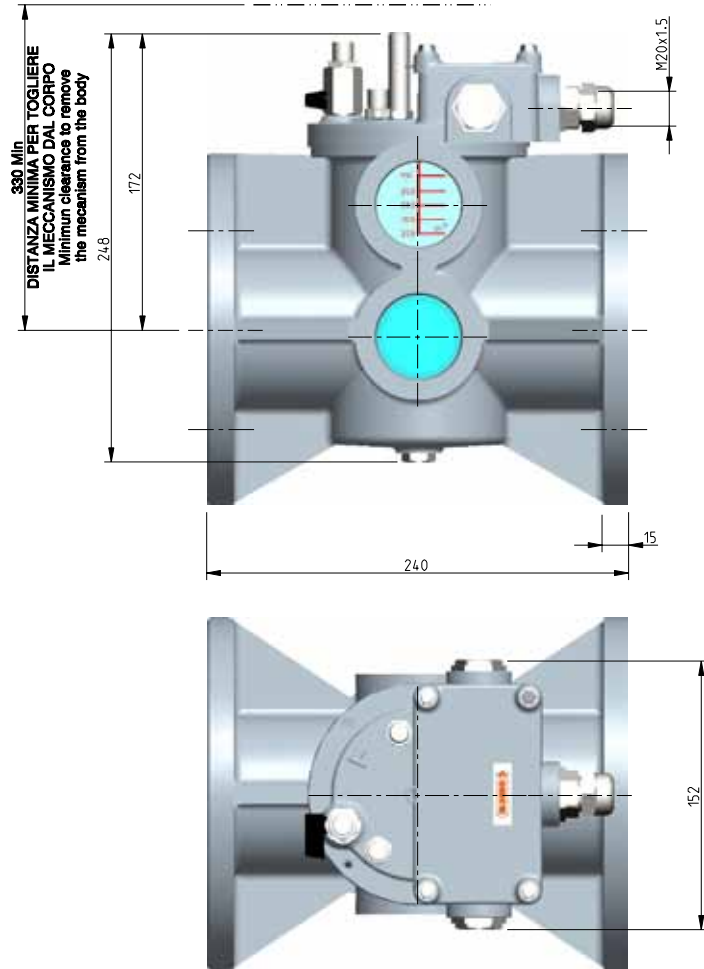

Weight 5.5 Kg

Buchholz relay

Overall dimensions according to EN 50216-2 and EN 50216-2_A1

C01

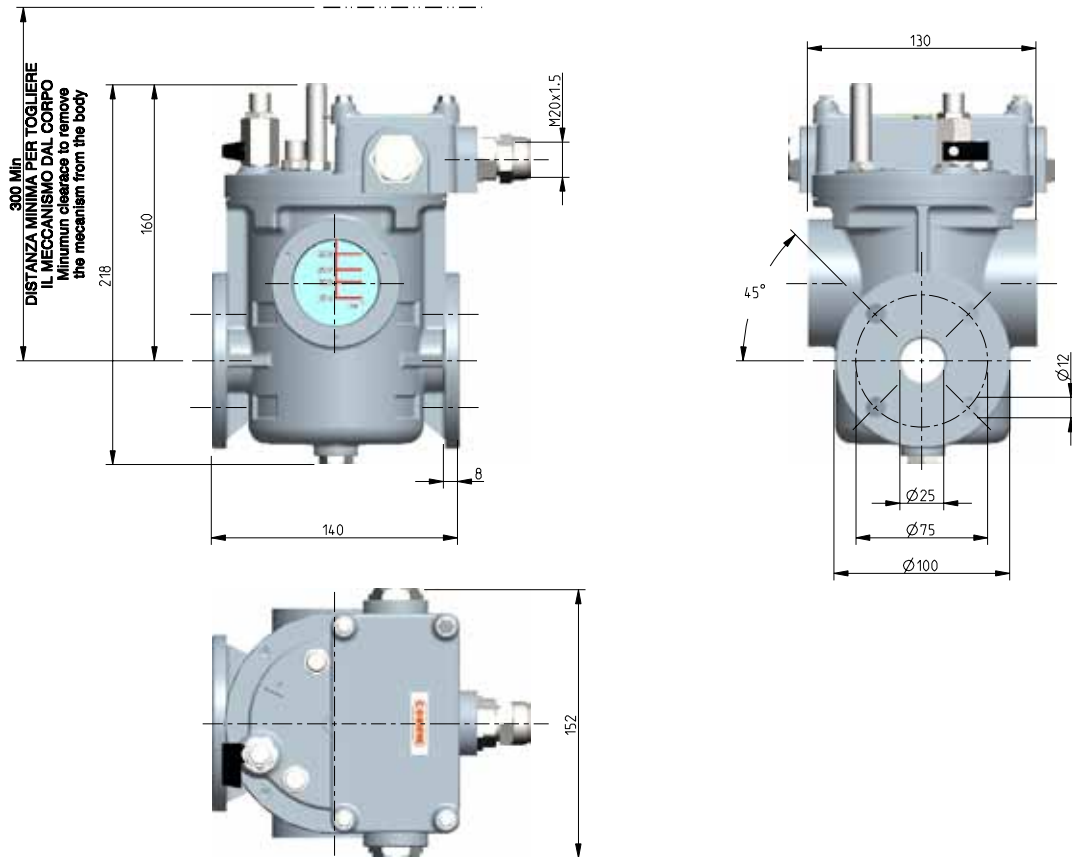

Weight 2.2 Kg

C1

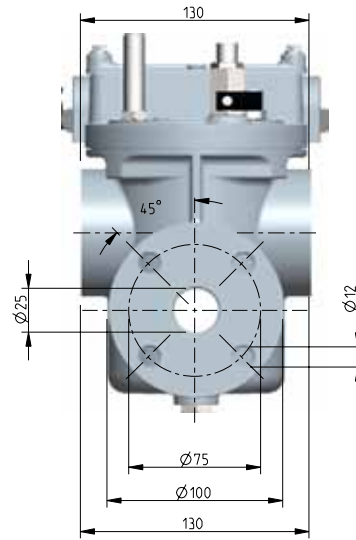
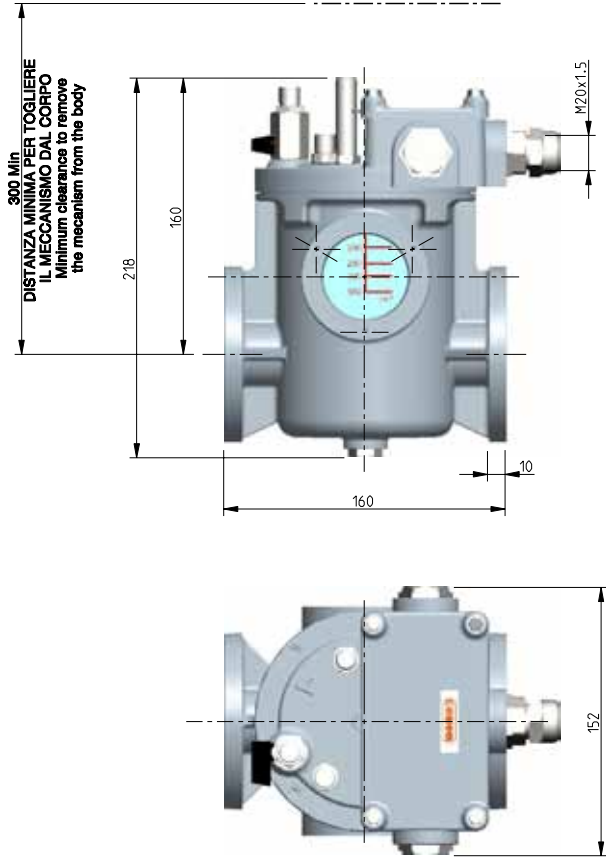

Weight 2.3 Kg

Buchholz relay

Overall dimensions according to EN 50216-2 and EN 50216-2_A1

C4

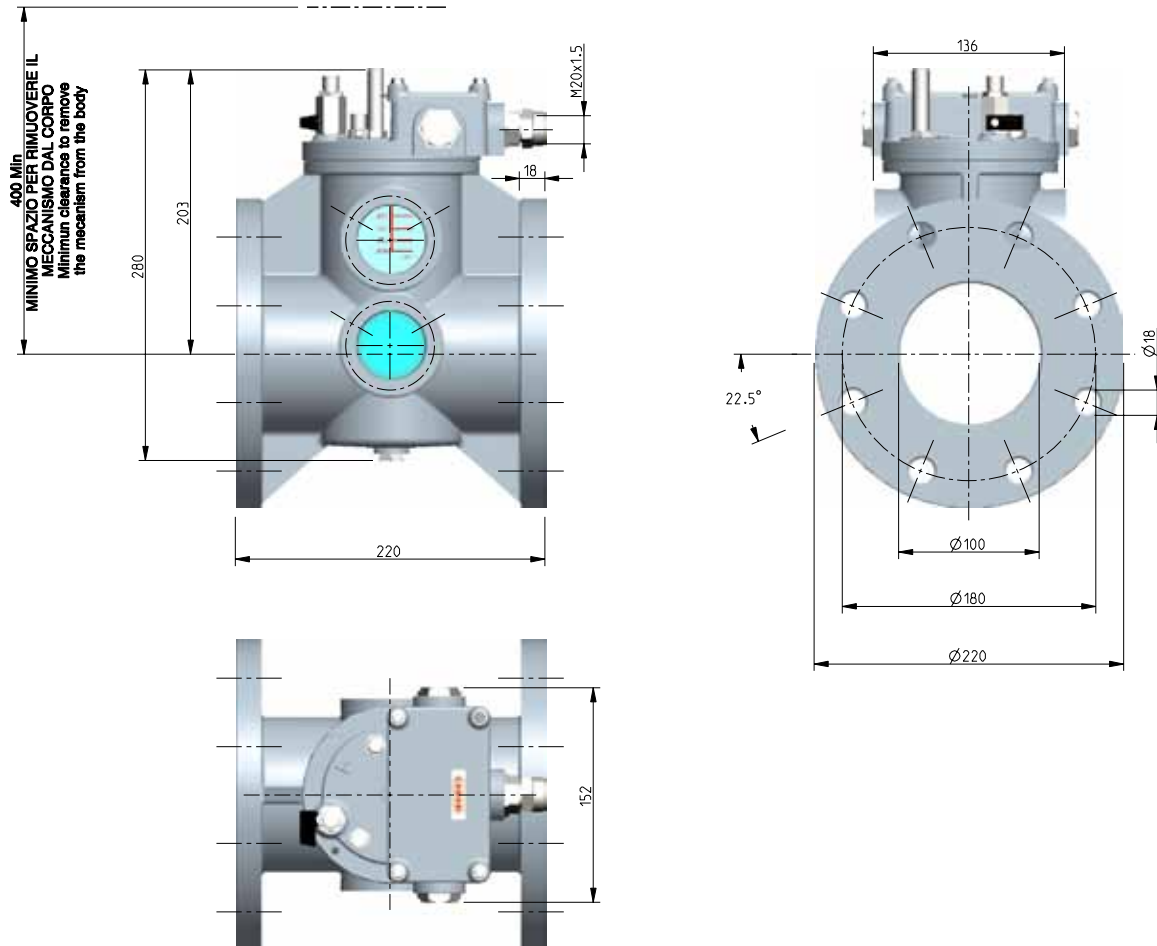

Weight 5.9 Kg

Main features

General data				
Material	All the external part are resistant to transformer oils, salt fog and UV rays			
Ambient temperature	-40 to 80°C			
Oil temperature	-40 to 115 °C			
Degree of protection	IP65 in accordance with EN60529			
Oil flow speed (oil temperature 20°C)	1.00 ± 0.15 m/s			
	1.50 ± 0.20 m/s			
	2.00 ± 0.30 m/s			
Switch electrical data (according to EN 50216-2 and EN 50216-2_A1)				
Breaking capacity	Voltage	Current	Breaking capacity	
	220 V d.c. (min. 12V)	2 A for 1000 maneuvers	250 W	L/R < 40 ms
	230 V a.c. (min. 12V)	6 A for 1000 maneuvers	400 VA	cosΦ > 0.5
Dielectric strength of contacts	Short duration power frequency withstand voltage 1 min – kV (r.m.s.)		Lightning impulse withstand voltage kV (peak)	
	Between circuits and earth		5	
	Across open contacts		3	

Alarm signalling Gas Volume	
Buchholz relay type	
BG25-BR25-NF25-C01-C1	100-200 cm ³
NF50-NF80	100-200 cm ³
BR50-BR80-C4	150-250 cm ³
BS25	170-230 cm ³
BS50-BS80	250-300 cm ³

Buchholz relay

Wiring diagrams

Diagram type "A"

- ALARM CONTACT (terminals 3-4)
NO contact
- TRIP CONTACT (terminals 1-2)
NO contact

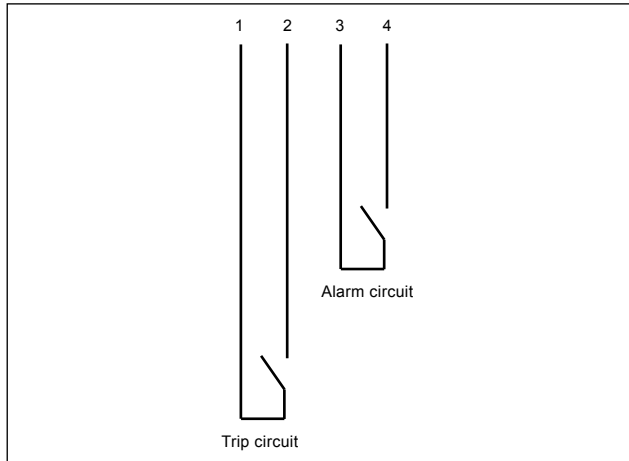

Diagram type "L"

- ALARM CONTACT (terminals 3-4- C2) change over contact
NO contact: terminals 4-C2; NC contact: terminal 3-4
- TRIP CONTACT (terminals 1-2-C1) change over contact
NO contact: terminals 2-C1; NC contact: terminal 1-2

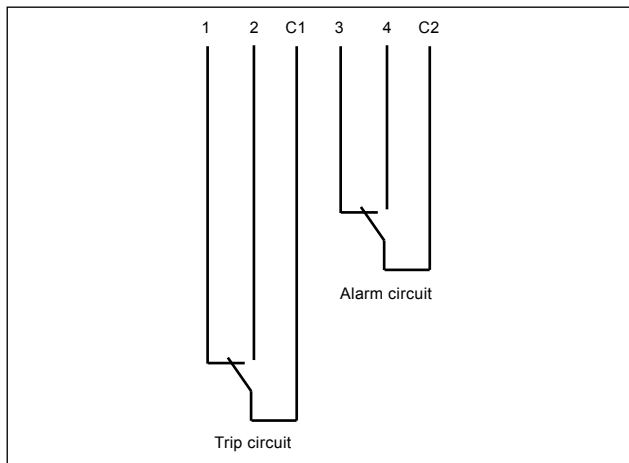

Diagram type "P"

- ALARM CONTACT (terminals C2-3)
NO contact
- ALARM CONTACT (terminals C1-4)
NO contact
- TRIP CONTACT (terminals 1-2)
NO contact

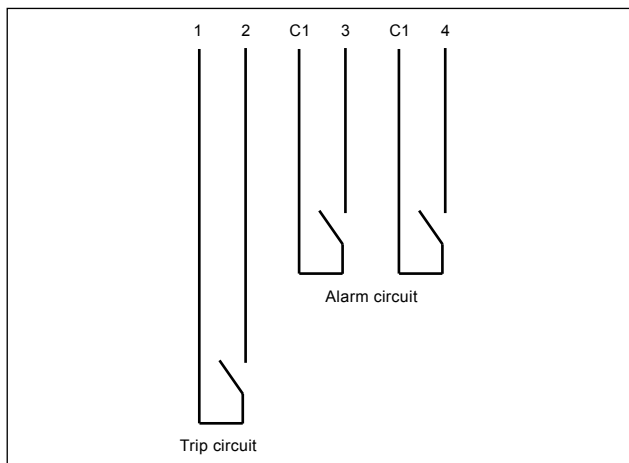

Diagram type "G"

- ALARM CONTACT (terminals 3-4)
NO contact
- TRIP CONTACT (terminals C2-2)
NO contact
- TRIP CONTACT (terminals C1-1)
NO contact

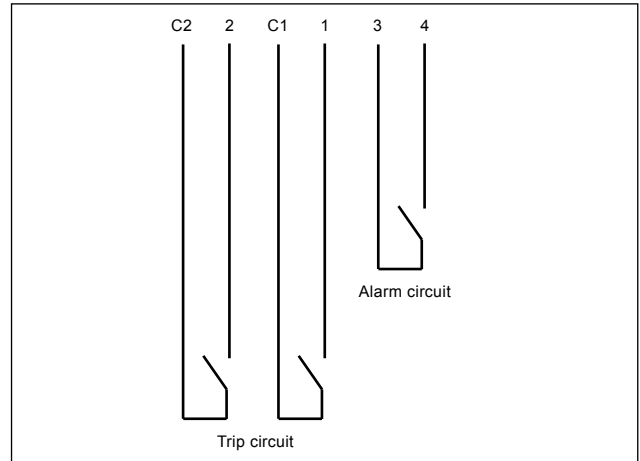

Diagram type "I"

- ALARM CONTACT (terminals 5-6)
NO contact
- ALARM CONTACT (terminals 7-8)
NO contact
- TRIP CONTACT (terminals 1-2)
NO contact
- TRIP CONTACT (terminals 3-4)
NO contact

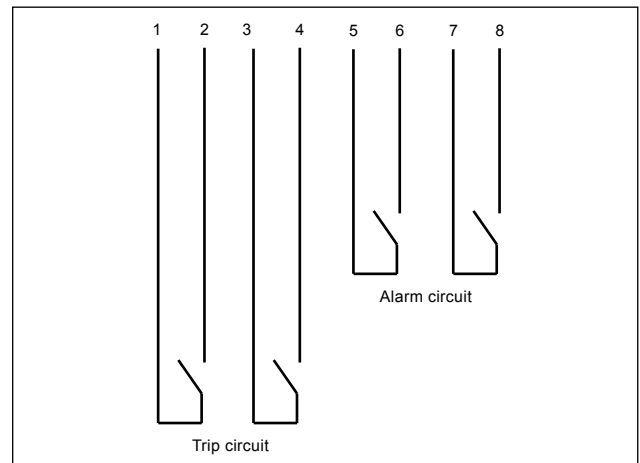
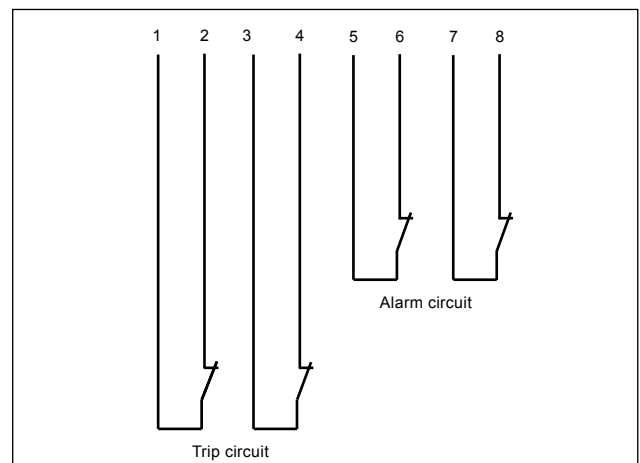

Diagram type "V"

- ALARM CONTACT (terminals 5-6)
NC contact
- ALARM CONTACT (terminals 7-8)
NC contact
- TRIP CONTACT (terminals 1-2)
NC contact
- TRIP CONTACT (terminals 3-4)
NC contact



Buchholz relay

Gas sampling device

Insulating materials within transformers and electrical equipment break down to liberate gases. The distribution of these gases can be related to the type of electrical fault, and the rate of gas generation can indicate the severity of the fault. The identity of the gases being generated by a particular unit can be very useful information in any preventative maintenance program.

The collection and analysis of gases in an oil-insulated transformer can indicate the severity of the default.

The presence of gas inside an oil filled transformer is always a sign of malfunction and one of the tasks of the Buchholz relay is to signal this presence. Analysis of the evolved gas can often give good indication of the type of malfunction but accessing the Buchholz relay during live operation of the transformer can be hazardous.

The gas sampling device has been designed to overcome this problem by siting the unit remote from the Buchholz relay and in a readily accessible position typically on the side of the transformer.

Construction

The COMEM gas sampling device is manufactured from an aluminium alloy casting with the following fittings:

- a tempered glass inspection window with graded markings for volume indication.
- a gas sampling valve (2).
- a bleed valve (3).
- a gas inlet valve for pneumatic testing (5).
- a valve for draining oil from the relay (this can be mounted on the right or left hand side of the body (6) or (7)).

As a routine test all castings are tested by injecting ambient air at 2.5 bar for 2 minutes. A certificate to this effect is supplied with the unit. For the sake of standardisation the device is fitted with the left and right hand valve supports but only one valve. Customer can then choose which side he prefers.

- with fittings for outside dia. 10 tubes, code 1RDPG00005 (standard);
- with fittings for outside dia. 6 tubes, code 1RDPG00006 (on request);
- with fittings for outside dia. 8 tubes, code 1RDPG00007 (on request).

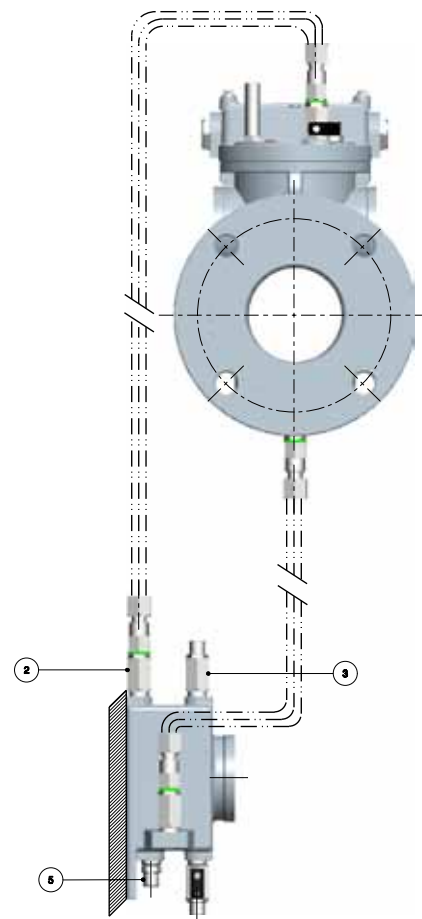
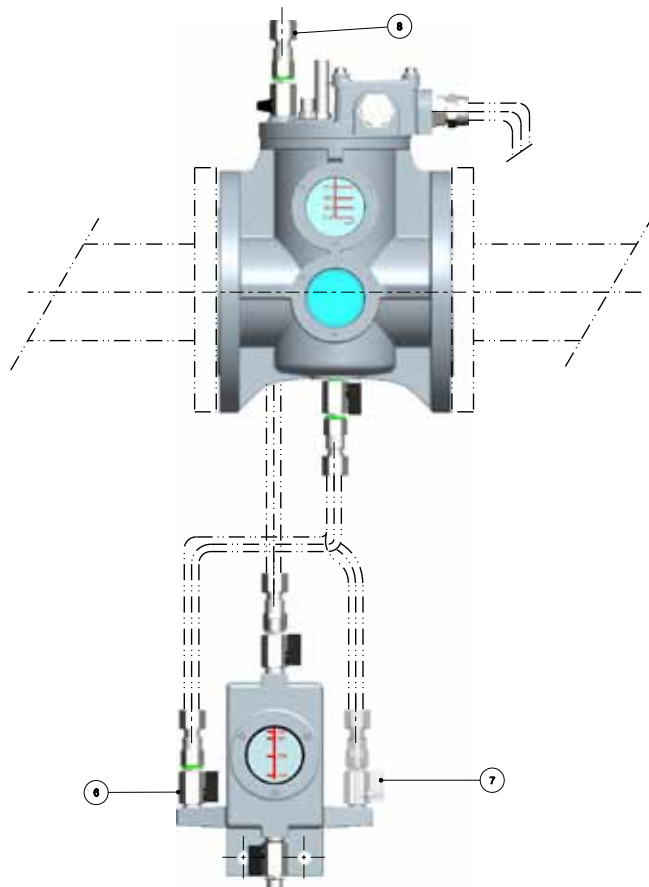

Requirement sheet

Number of pieces								
Size and model	BG25	BR25	BR50	BR80	BR80 8 holes	BS25	BS50	BS80
	<input type="checkbox"/>	<input type="checkbox"/>	<input type="checkbox"/>	<input type="checkbox"/>	<input type="checkbox"/>	<input type="checkbox"/>	<input type="checkbox"/>	<input type="checkbox"/>
Electric contact layout	NF25	NF50	NF80	C01	C1	C4		
	<input type="checkbox"/>	<input type="checkbox"/>	<input type="checkbox"/>	<input type="checkbox"/>	<input type="checkbox"/>	<input type="checkbox"/>	<input type="checkbox"/>	<input type="checkbox"/>
Sealing	A	L	P	G	I	V		
	<input type="checkbox"/>	<input type="checkbox"/>	<input type="checkbox"/>	<input type="checkbox"/>	<input type="checkbox"/>	<input type="checkbox"/>	<input type="checkbox"/>	<input type="checkbox"/>
For use in:	NBR -40°						VITON	
							<input type="checkbox"/>	<input type="checkbox"/>
Option available upon request:	Moderate salinity areas acc. to ISO 12944							
Gas sampling device	Off-shore areas acc. to ISO 12944							
Gas sampling device	Tube 6 mm	Tube 8 mm	Tube 10 mm					
	<input type="checkbox"/>	<input type="checkbox"/>	<input type="checkbox"/>					

Gas relay

Distribution transformers have the same working principle of Power transformers therefore they are influenced by the same fault principles. However, their specific design requires a different approach when talking about safety devices: COMEM Gas relay is the right solution for detecting the internal gas generated by various phenomena like dielectric failure, slight overload and degradation of insulating oil.

R1

Gas accumulation is monitored and kept under control by the gas relay. Ensure air bag functionality within the oil conservator.



Additionally, all kind of transformers may be equipped with oil conservator air bag (air cushion embedded into the oil conservator) and it is fundamental to ensure its correct functioning: thanks to COMEM Gas relay flexibility, it can be used for promptly detecting unexpected deflation or punching by stopping the transformer.

Working principle

For Distribution transformers, the gas relay is mounted on the transformer tank.

When gas is generated in the transformer it rises towards the conservator and collects in the upper chamber of the relay. The oil level drops and the top float triggers alarm switch.

Gas shall not freely pass from the relay body and escape into the pipework before the alarm contact has operated.

Alternatively, it is mounted on top of oil conservators and once there is a sudden air flow from air bag it trips the transformer.

Gas relay

Overall dimensions

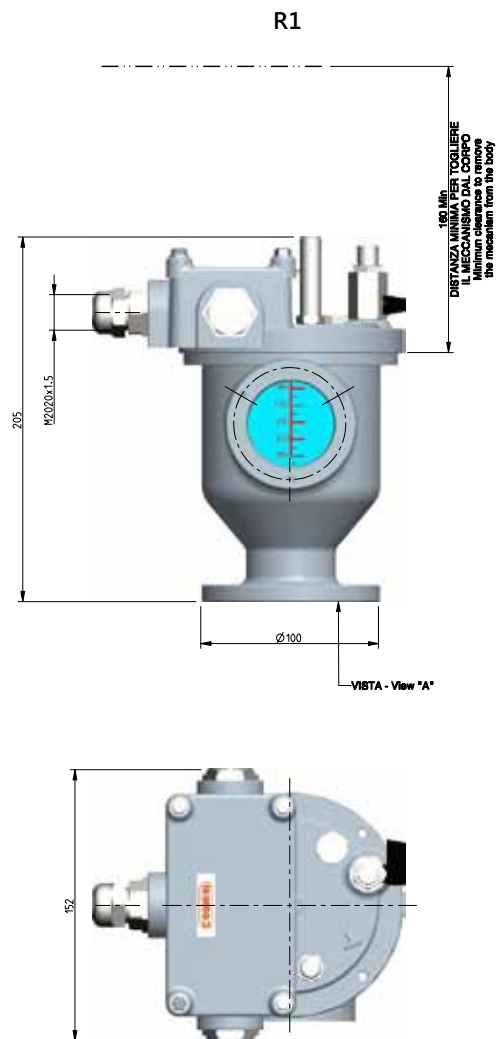

Weight 1.9 Kg

RF1

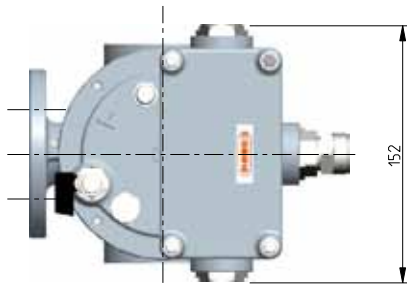
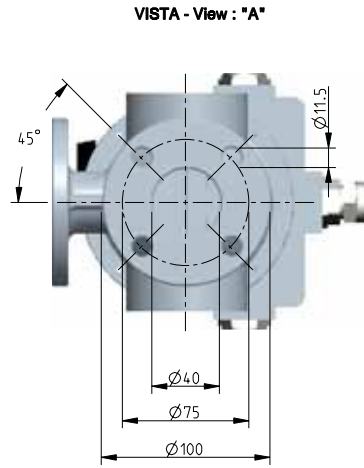
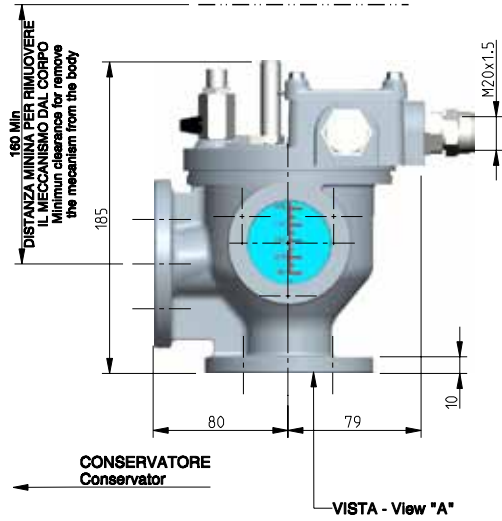

Weight 2.2 Kg

Gas relay

Main features

General data	
Material	All the external part are resistant to transformer oils, salt fog and UV rays
Ambient temperature	-40 to 80°C
Oil temperature	-40 to 115 °C
Degree of protection	IP65 in accordance with EN60529
Oil flow speed (oil temperature 20°C)	1.00 ± 0.15 m/s
	1.50 ± 0.20 m/s
	2.00 ± 0.30 m/s

Switch electrical data (according to EN 50216-2 and EN 50216-2_A1)			
Breaking capacity	Voltage	Current	Breaking capacity
	220 V d.c. (min. 12V)	2 A for 1000 maneuvers	250 W L/R < 40 ms
	230 V a.c. (min. 12V)	6 A for 1000 maneuvers	400 VA cosΦ > 0.5
Dielectric strength of contacts	Short duration power withstand voltage 1 min – kV (r.m.s.)		Lightning impulse withstand voltage kV (peak)
	Between circuits and earth		5
	Across open contacts		3

Operating pressure - 1 bar, tested to 2,5 bar for 2 minutes at 100 deg C.

Alarm signalling Gas Volume	
Buchholz relay type	
R1 - RF1	75 cm ³

Wiring diagrams

Diagram type "A"

- ALARM CONTACT (terminals 3-4)
NO contact
- TRIP CONTACT (terminals 1-2)
NO contact

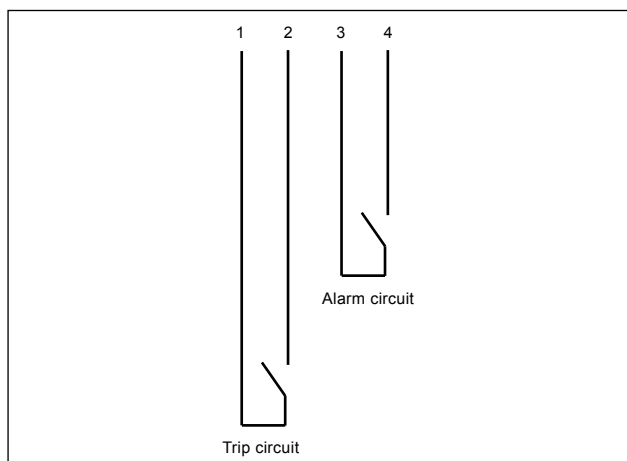
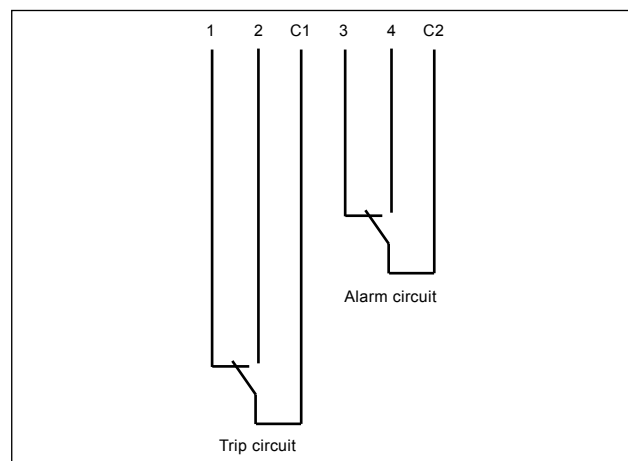

Diagram type "L"

- ALARM CONTACT (terminals 3-4- C2) change over contact
NO contact: terminals 4-C2; NC contact: terminal 3-4
- TRIP CONTACT (terminals 1-2-C1) change over contact
NO contact: terminals 2-C1; NC contact: terminal 1-2



Requirement sheet

Number of pieces		
Size and model	R1 <input type="checkbox"/>	RF1 <input type="checkbox"/>
Electric contact layout	A <input type="checkbox"/>	L <input type="checkbox"/>
Sealing	NBR-40°C <input type="checkbox"/>	VITON <input type="checkbox"/>
For use in:	Moderate salinity areas acc. to ISO 12944 <input type="checkbox"/>	
	Off-shore areas acc. to ISO 12944 <input type="checkbox"/>	

Flow relay

The flow Relay is used as a protective device sensitive to the effects of dielectric failure inside the energized (on load) tap-changer.

The flow relay detects a failing transformer. If an arc forms, gas accumulation is rapid, and oil flows rapidly into the conservator. This flow of oil operates a switch attached to a vane located in the path of the moving oil. This switch normally will operate a circuit breaker to isolate the apparatus before the fault causes additional damage.

OR-25 relay

Promptly detect leakages from Energized Tap Changers oil compartment to the oil conservator.



The relay for OLTC application is positioned in the pipe work between the on-load tap-changer head and the oil conservator. This relay responds only if oil flow occurs from the on-load tap-changer head to the oil conservator. If this happens, the flow vane switches the reed . The circuit breakers are tripped and the transformer is de-energized.

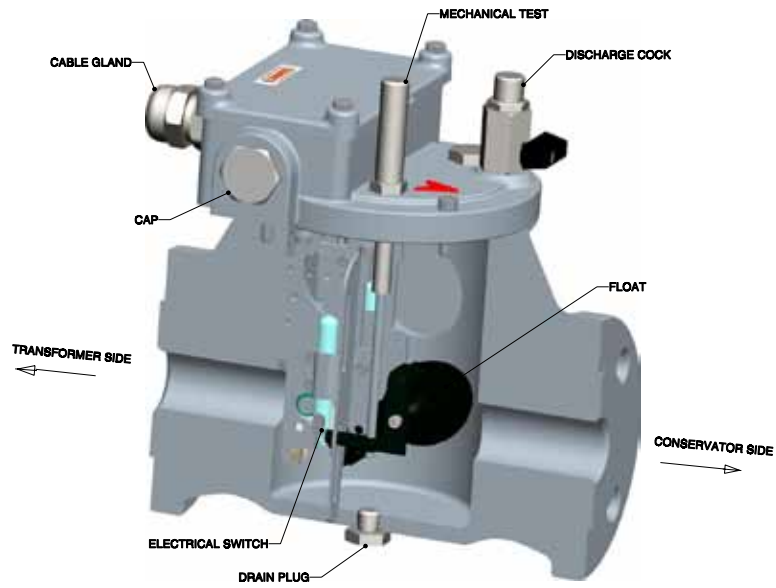

Advantages

- Complete protection for both the energized tap-changer and the transformer
- Detection of any eventual malfunctioning or failure in the diverter switch or sector oil compartment
- Transformer trip

Flow relay

Overall dimensions

OR25

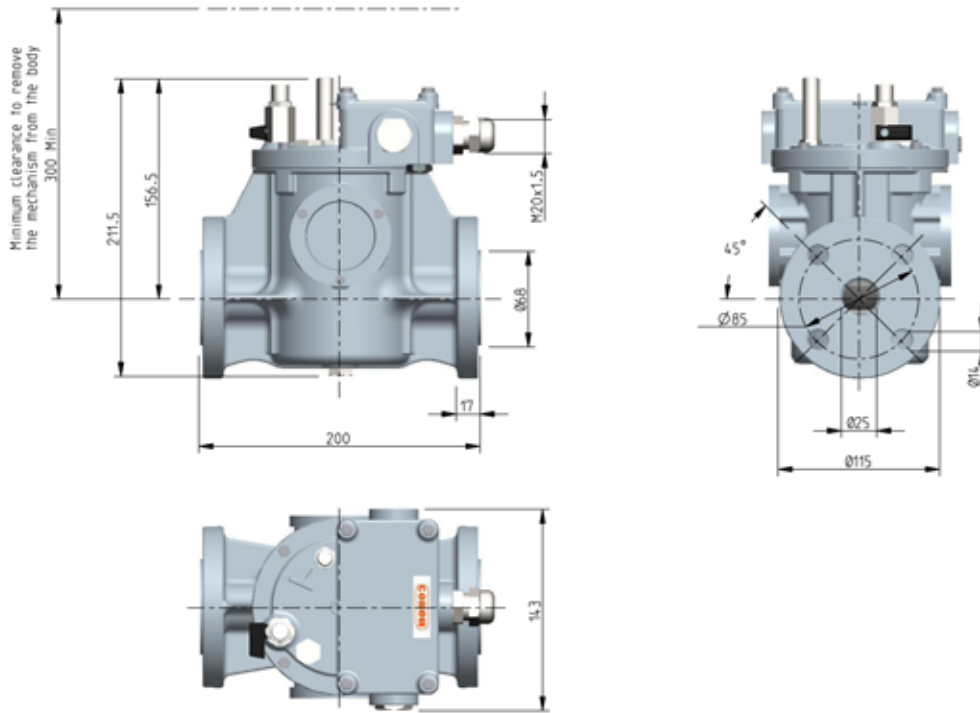

Weight 2.9 Kg

Main features

General data				
Material	All the external part are resistant to transformer oils, salt fog and UV rays			
Ambient temperature	-40 to 80°C			
Oil temperature	-40 to 115 °C			
Degree of protection	IP65 in accordance with EN60529			
Oil flow speed (oil temperature 20°C)	0.70 ± 0.15 m/s			
	1.00 ± 0.15 m/s			
	1.50 ± 0.20 m/s			
	2.00 ± 0.30 m/s			
Switch electrical data (according to EN 50216-2 and EN 50216-2_A1)				
Breaking capacity	Voltage	Current	Breaking capacity	
	24 V DC to 220 V DC	2 A for 1000 maneuvers	250 W	L/R < 40 ms
	230 V AC	2 A for 1000 maneuvers	400 VA	cosΦ > 0.5
Dielectric strength of contacts	Short duration power frequency withstand voltage 1 min – kV (r.m.s.)		Lightning impulse withstand voltage kV (peak)	
	Between circuits and earth		4	
	Across open contacts		3	

Tests

Type test:	Relevant Standard	Routine test	Relevant Standard
Vibration test	EN 60137-3-4 EN 60068-3-3	Oil leakage test in hot oil (90°C for 30 minutes at 100kPa)	EN 50216-2 and EN 50216-2_A1
Vacuum test (2.5 kPa for 24 hours)	EN 50216-2 and EN 50216-2_A1	Operation test	
Leakage test (250 kPa for 2 minutes at 100°C)	EN 50216-2 and EN 50216-2_A1	Mechanical test	EN 50216-2 and EN 50216-2_A1
Salt fog test (500 hours)	UNI EN ISO 9227	Flow vane test	EN 50216-2 and EN 50216-2_A1
Degree of protection IP65	EN 60529	Dielectric test	EN 50216-2 and EN 50216-2_A1

Flow relay

Wiring diagrams

Diagram type "AO"

- TRIP CONTACT (terminals 1-2)
- NO contact

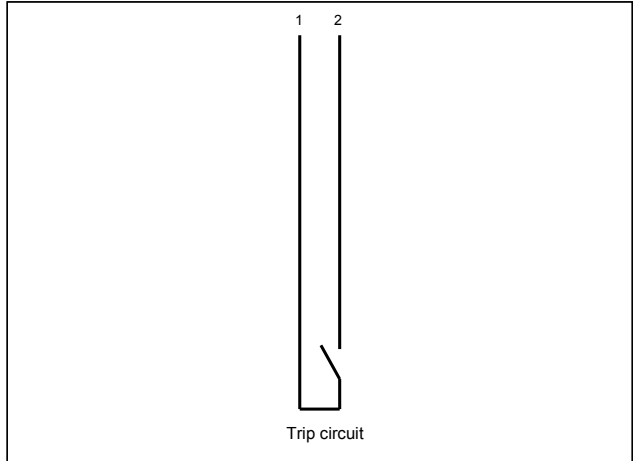

Diagram type "LO"

- TRIP CONTACT (terminals 1-2-3) change over contact
- NO contact: terminals 2-3; NC contact: terminal 1-2

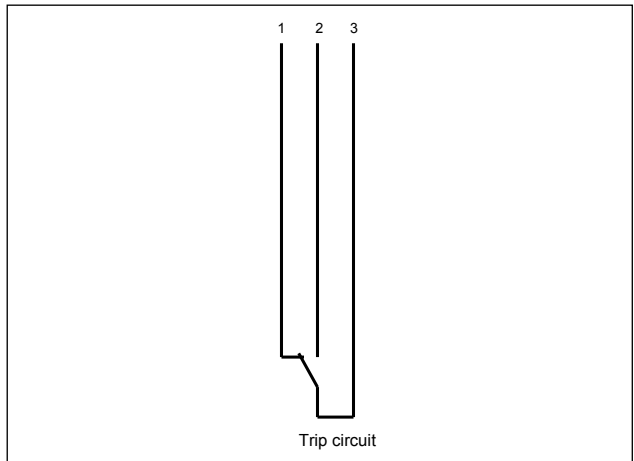

Diagram type "GO"

- TRIP CONTACT (terminals 1-2)
- NO contact
- TRIP CONTACT (terminals 3-4)
- NO contact

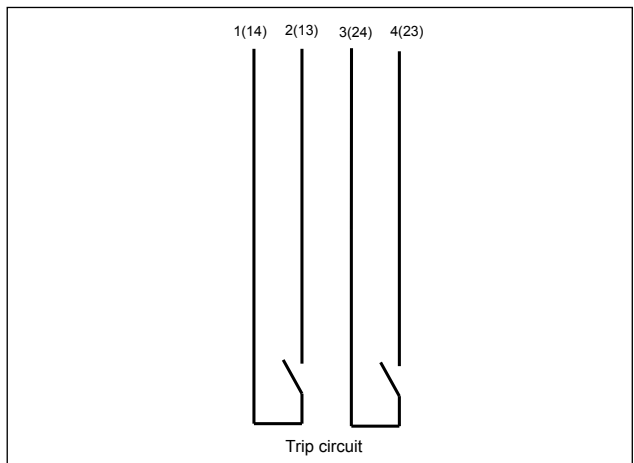

Diagram type "VO"

- TRIP CONTACT (terminals 1-2)
NC contact
- TRIP CONTACT (terminals 3-4)
NC contact

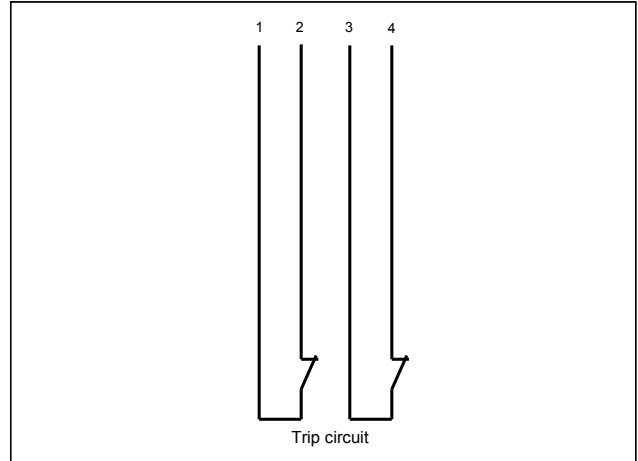

Diagram type "RO"

- TRIP CONTACT (terminals 1-2)
NC contact
- TRIP CONTACT (terminals 3-4)
NO contact

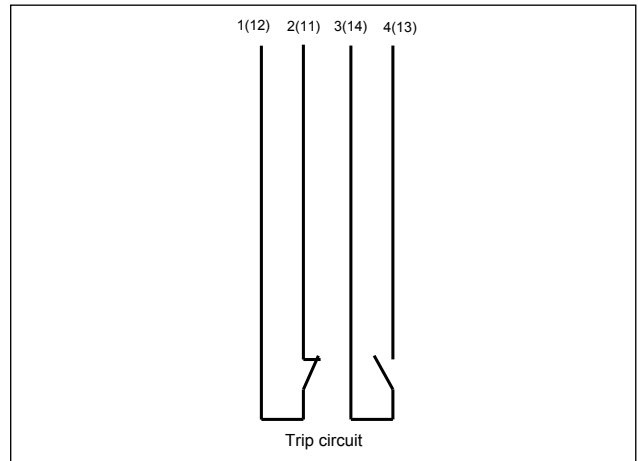
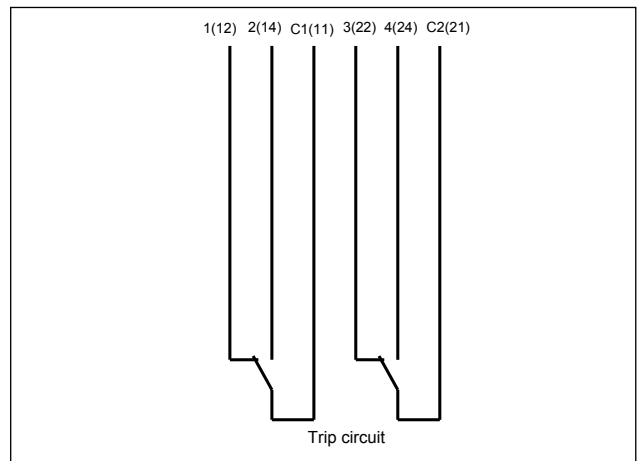

Diagram type "CO"

- TRIP CONTACT (terminals 1-2-C1) change over contact
NO contact: terminals 2-C1; NC contact: terminal 1-C1
- TRIP CONTACT (terminals 3-4-C2) change over contact
NO contact: terminals 4-C2; NC contact: terminal 3-C2



Flow relay

Wiring diagrams

Diagram type "TO"

- TRIP CONTACT (terminals 1-2-C1) change over contact
NO contact: terminals 2-C1; NC contact: terminal 1-C1
- TRIP CONTACT (terminals 3-4)
NO contact

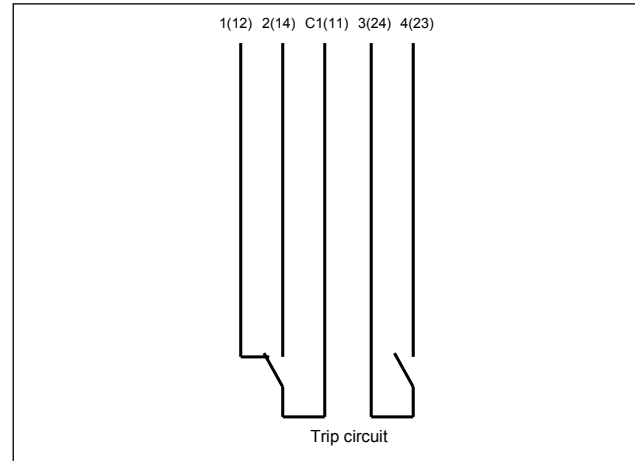

Requirement sheet

Number of pieces								
Size and model	OR25 <input type="checkbox"/>							
Electric contact layout	<table style="display: inline-table; border: none;"> <tr> <td style="text-align: center;">AO <input type="checkbox"/></td> <td style="text-align: center;">LO <input type="checkbox"/></td> <td style="text-align: center;">GO <input type="checkbox"/></td> <td style="text-align: center;">VO <input type="checkbox"/></td> <td style="text-align: center;">RO <input type="checkbox"/></td> <td style="text-align: center;">CO <input type="checkbox"/></td> <td style="text-align: center;">LO <input type="checkbox"/></td> </tr> </table>	AO <input type="checkbox"/>	LO <input type="checkbox"/>	GO <input type="checkbox"/>	VO <input type="checkbox"/>	RO <input type="checkbox"/>	CO <input type="checkbox"/>	LO <input type="checkbox"/>
AO <input type="checkbox"/>	LO <input type="checkbox"/>	GO <input type="checkbox"/>	VO <input type="checkbox"/>	RO <input type="checkbox"/>	CO <input type="checkbox"/>	LO <input type="checkbox"/>		
Sealing	NBR <input type="checkbox"/>							
For use in:	Moderate salinity areas acc. to ISO 12944 <input type="checkbox"/>							
	Off-shore areas acc. to ISO 12944 <input type="checkbox"/>							