

**BAND-IT® Tie-Dex II®
Banding Tools
600-058
600-061
Operating Instructions**



Band-It® Standard, Micro and Nano Overview

1 Calibration Access Plug

2 Tensioning Lever:

Squeeze with short gentle strokes to tighten band to the proper tension. Lever will lock to 3 Handle with final full stroke.

4 Cut-Off Lever:

Squeeze to lock band buckle and trim excess band material.

5 Band Insertion and Release Lever: Depress lever to insert or release band from tool.

6 Serial Number

7 Tension Release Lever

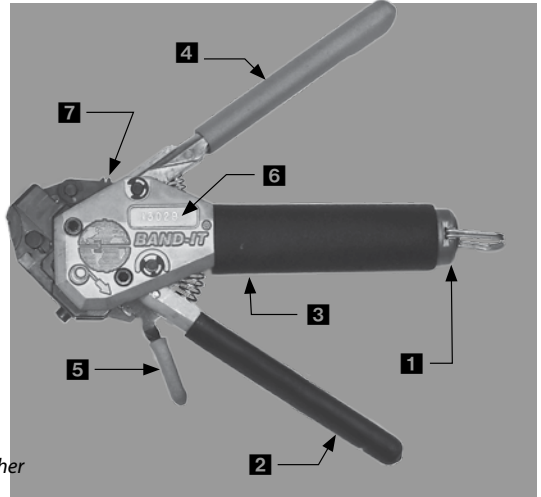

NOTES:

1. Use only genuine Glenair/Band-It bands. Other manufacturer's bands may damage tool.
2. Use only .240" wide bands with 600-058 tool and .120" wide bands with 600-061 tool.

Shield Termination Preparation Process

Step 1

Prepare Cable Braid for termination process.

NOTE: banding must occur on an unfixtured cable assembly. Attaching a band to a firmly clamped cable will affect the applied forces and will also interfere with the cut-off operation. The cut-off operation causes a rotation of the band termination in order to lock the band.

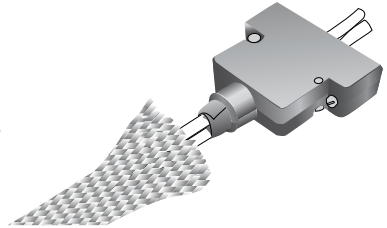

Step 2

Push braid forward over banding platform. Milk braid as required to remove slack and insure a snug fit around the shield termination area.

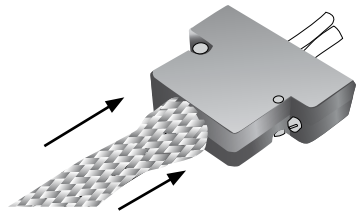

Shield Termination Assembly Process

Step 3

Double-coil the band prior to use:

IMPORTANT: *Due to connector/adaptor circumference, it may be necessary to double-coil the band in place around the cable or retention area.*

A. Insert leading edge of band through the buckle slot twice. (Bands must be double-coiled.)

B. Tighten the coil until the indicator mark (▷|) is approximately .250 inch (6.4mm) shy of the buckle slot (see illustration below). This will ensure sufficient band tail length for insertion into tool.

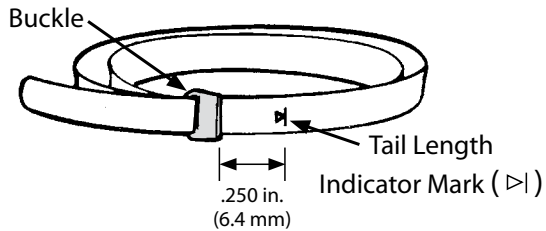

Step 4

Depress the band insertion and release lever (5), and insert the band into the front end opening of the tool, with the loop positioned outward as shown.

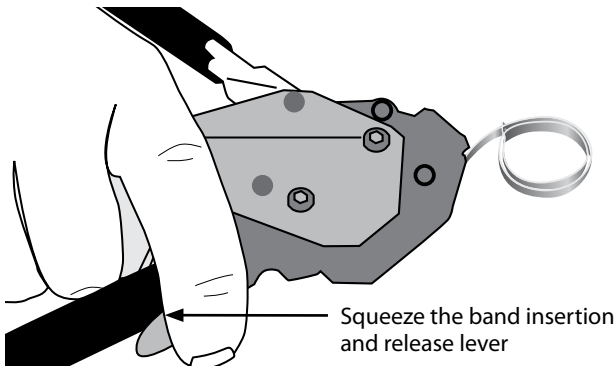

Shield Termination Assembly Process

Step 5

The band termination area on all backshells is wider than the band. Position the band near the rear lip of the banding platform, allowing room for buckle. For elliptical cable entries position the buckle off center of the peak of the circle. Failure to follow these guidelines will result in poor performance.

Position the band near the rear lip leaving room for buckle.



Position the buckle off-center as shown

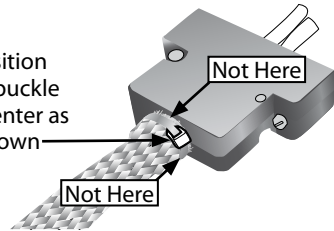

Step 6

Contract the band with the tensioning lever (2) using short, even strokes, as the band is firmly secured on termination area pull a full stroke to lock handle handle against the tool body indicating the band is compressed to the proper tension.

NOTE: *Overly rapid tightening of the band may result in uneven compression. If alignment of the band and shield is unsatisfactory, tension can be relaxed by pulling up tension lever (2) and pushing the release lever (7) forward on top of the tool. Make adjustments as necessary and finish tightening with tensioning lever (2) as described above. Instructional videos are available on the Glenair website: www.glenair.com/banding/*

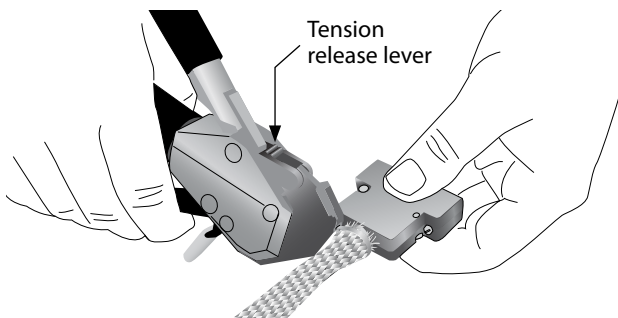

Shield Termination Assembly Process

Step 7

Complete the clamping process by depressing the cut-off lever (4), allowing band and cable to rotate slightly.

Note: Always install bands on an unfixtured connector/cable assembly.

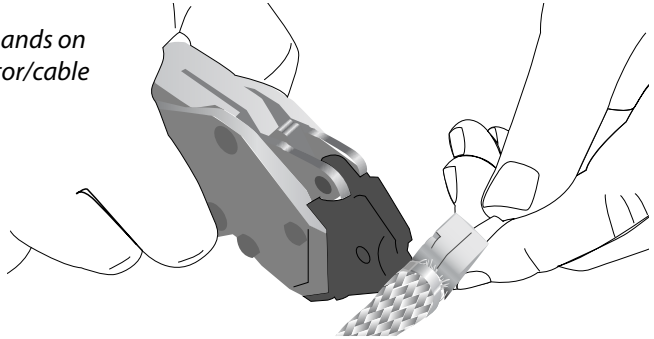

Step 8

Pull up the release lever (5) to remove excess band for disposal.

Step 9

Trim away excess braid from the forward groove, particularly if a shrink boot is to be applied to the assembly.

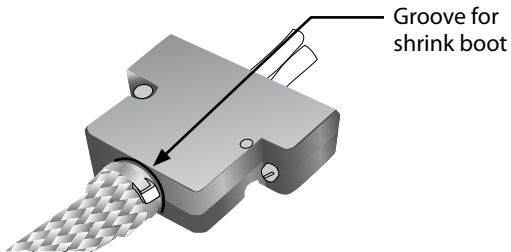

Step 10

Visually inspect shield termination for problems.

NOTE: Band can be removed by lifting buckle with a screwdriver or diagonal cutters.

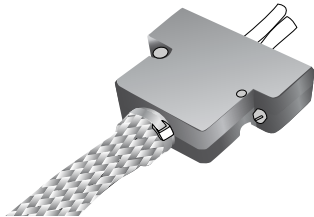

Tool Calibration

Band-It® tools are factory-calibrated and are supplied with a calibration certificate. Glenair recommends that tool calibration be checked after 500 terminations. Actual calibration interval can be determined by tool users. Glenair also provides calibration services. A portable kit is available for on-site calibration. Factory calibration values are 150 ± 5 lbs for standard band tool 601-100, and 80 ± 5 lbs for the micro band tool 601-101.



601-200 Calibration Kit For All Banding Tools

The 601-200 Calibration Kit provides fast, easy, accurate calibration of all banding tools.

Kit includes the (1) 601-200-3 Calibration Device, (2) Fifty 600-065-2 Micro Test Bands, (3) Fifty 600-065-1 Standard Test Bands, (4) 600-055 Calibration Key, (5) 600-065-5 Standard Tool Adapter for 600-058, 600-067 (installed) (6) 600-065-6 Micro tool adapter for 600-061, 600-068. Range of the calibration device is 60 to 170 lbs, and accuracy is calibrated to ± 1 lb. at factory. Dimensions: 6.65 in. x 2.47 in. x 2.83 in. (168.9 x 62.7 x 71.9mm). Weight: 2.10 lbs. (1.0Kg).

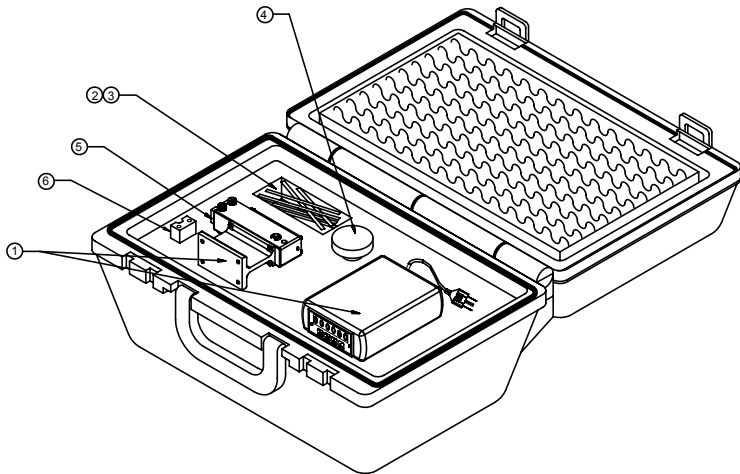

Tool Repair and Refurbishment

Glenair provides repair and refurbishment services for **Band-It®** tools. Typical services include calibration along with replacements of cutter knife and cut-off blade. Simply send the tool to Glenair:

ATTN: Customer Service
Glenair, Inc.
1211 Air Way
Glendale CA 91201

Pneumatic Tools for High Volume Production

Pneumatic **Band-It®** tools speed up band installation and reduce operator fatigue.

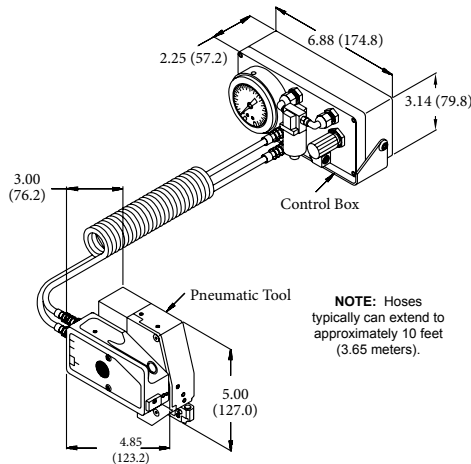

Band-It® Pneumatic Banding Tools

The Tie-Dex II® Pneumatic Banding Tools provide fast, easy band installation.

Weight of the tool is 2.52 lbs (1.14 Kg); the control box weighs 2.74 lbs (1.24 Kg).

600-067 for use with standard bands.

600-068 for use with micro bands.

600-074 Foot Pedal Control for Pneumatic Banding Tools

free both hands to help assure more accurate, reliable and faster shield terminations.

