

In touch with the medium

» BEDIA Level monitoring sensors

Typ PLS 40 DC 12/24 V

Typ PLS 45 DC 5 V

Typ PLS 30 DC 12/24 V

General description	4
Measurable mediums	5
Output	6
Installation instruction.....	7
Functionality overview level probes minimum	8
Functionality overview level probes maximum	9
Level probes type PLS 40	10
Probes with connector bayonet DIN 72585.....	10
Probes with cable.....	12
Probes with connector bayonet 16 S.....	14
Probes with thread M 27 x 1	15
Probes with connector bayonet 10 SL	16
Probes with connector DIN 43650	17
Probes with connector bayonet 16 S	18
Technical data PLS 40 probes.....	20
Level probes type PLS 45	22
Probes type PLS 45 description	22
Technical data PLS 45 probes.....	23
Special accessories for level probes type PLS 40 and type PLS 45	24
Level probes type PLS 30	26
Probes with connector bayonet 10S L	26
Probes with cable and connector bayonet 10 SL	27
Technical data PLS 30 probes.....	28

» General description

Level monitoring sensor with approvals

These sensors monitor the level of aqueous and oily liquids. They are used in:

- » engines
- » utility vehicles
- » ships
- » sets of machines

In engines these sensors monitor the level of:

- » cooling water, oil level and fuel container

These sensors are used reliably for automatic filling and refilling of liquids, such as for supplying engine oil and fuel service tanks.

Wherever pressure switches or temperature probes are today used as level monitoring elements, this sensor offers the advantage of its indicating a critical condition far sooner:

Temperature probes frequently react too late, because the medium to be monitored is no longer present. The rise in temperature is not passed on to the pick-up sensor. Pressure switches do not indicate low oil until there is a total shortage of oil and thus too late to protect the engine. The level sensor issues a warning when there is still enough medium present.



Probe for aqueous liquids



Probe for oily liquids

BEDIA Level Monitoring Sensors differ from float-type switches through their compact design and their resistance to vibration:

Since they contain no mechanical moving parts, their functioning cannot be influenced either by soil particles or other influences. No current is sent into the medium via an electrode with BEDIA sensors, and so insulation of the probe and electrolysis in the system are not possible.

» Measurable mediums

How the sensor functions

The level sensor functions on the capacitive principle. It detects the change in capacitance that develops when an electrode surrounded by air is immersed in a liquid medium. This change in capacitance on the electrode of the sensor excites an oscillator, causing it to vibrate (at a frequency of approx. 600 kHz). This signal is then processed by digital evaluation electronics.

Capacitance measurement

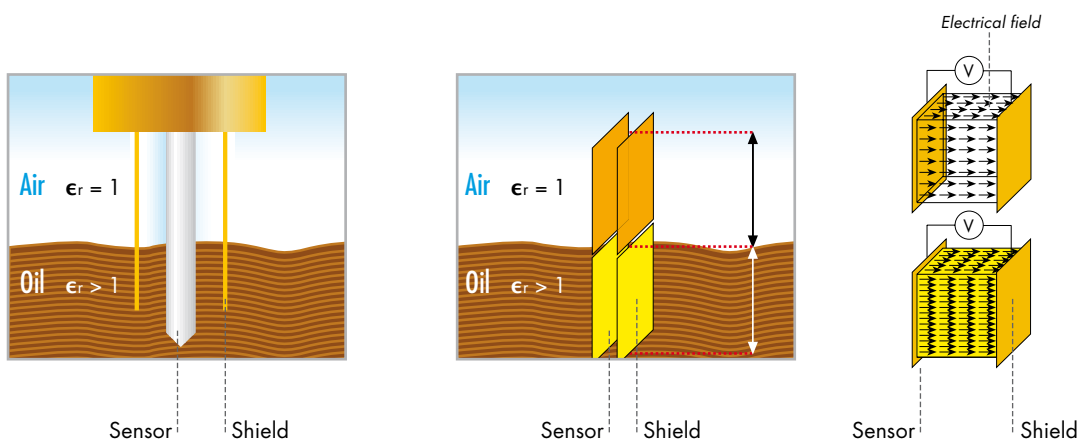

Medium variants

- » For electrically conductive liquid mediums with relative permittivity within a range of ϵ_r : 35 ... 85 (water, coolant, water/glucose mixture)
- » And for electrically non-conductive liquid mediums with relative permittivity within a range of ϵ_r : 1.8 ... 6 (engine oil, fuels, hydraulic oil)

» Output

Circuitry output

The probes have a short-circuit-proof switch output:

Minus switching: The output transistor switches minus potential to the load
Plus switching: The output transistor switches plus potential to the load

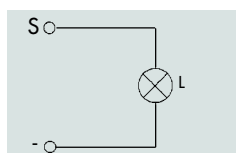

Plus switching

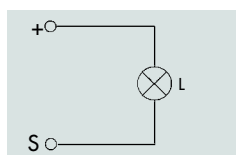
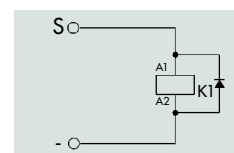

Minus switching

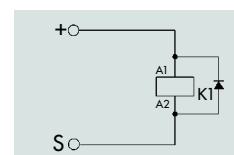

With switching currents over 1 A, a relay has to be inserted. To do so, a free-wheeling diode has to be connected parallel to the relay as an overvoltage protective device with inductive loading (see technical specs).

Automatic operational check

The sensors have an approx. two-second operational check built in as standard. When the power supply is applied (such as ignition being switched on), this signal appears for approx. two seconds, thus signalling readiness to function. If this signal does not appear, the sensor should be checked. This self-monitoring makes it possible to check the level monitoring sensors from a central point for their readiness to function as well as for cable breakage. Especially in intricate, rambling systems, such as ships, checking conventional level switches is very difficult.

Further function control times are also available upon request.

Monitoring delay

To avoid indication errors when the surface of the liquid is fluctuating producing brief shortages and excesses in the level, the output signal comes as standard with the indication delayed by approx. seven seconds.

Further indication delay times are available upon request.

» Installation instruction

Mounting position

BEDIA Level Monitoring Probes may be installed in any attitude.

The level sensors have to be installed in a calmed zone so that the medium does not constantly moisten the level sensor by sloshing and splashing, which would cause error messages.

This point is usually applicable for installation in gearboxes or for direct installation in engine oil pans during operation. In such cases, the correct level is only possible during standstills.

When carrying out the installation, be sure that the distance from the sensor probe to the wall is at least 7 mm.

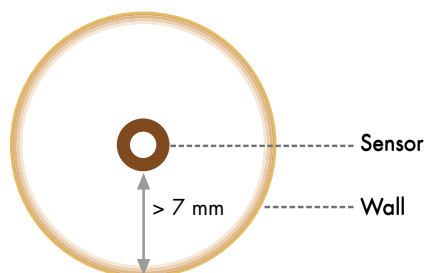

Only for water-sensors

If the sensor is installed from above in a plastic container, error messages might come about under certain circumstances if the medium does not conduct any potential. When installed in all other positions, the casing will come into contact with the medium. This guarantees that potential will be present.

» Functionality overview

Level probes minimum

Level probes minimum

If a minimum probe is removed from the medium, its outlet becomes active after the report delay. If it is a working current probe, its outlet becomes low-impedance after the report delay and a signal is available at the outlet. If it is a quiescent current probe, its outlet becomes high-impedance after the report delay and there is no longer a signal available at the outlet.

If a minimum probe is immersed in the medium, its outlet immediately becomes passive. If it is a working current probe, its outlet becomes high-impedance after immersion and a signal is no longer available at the outlet. If it is a quiescent current probe, its outlet becomes low-impedance after immersion and there is a signal available at the outlet.

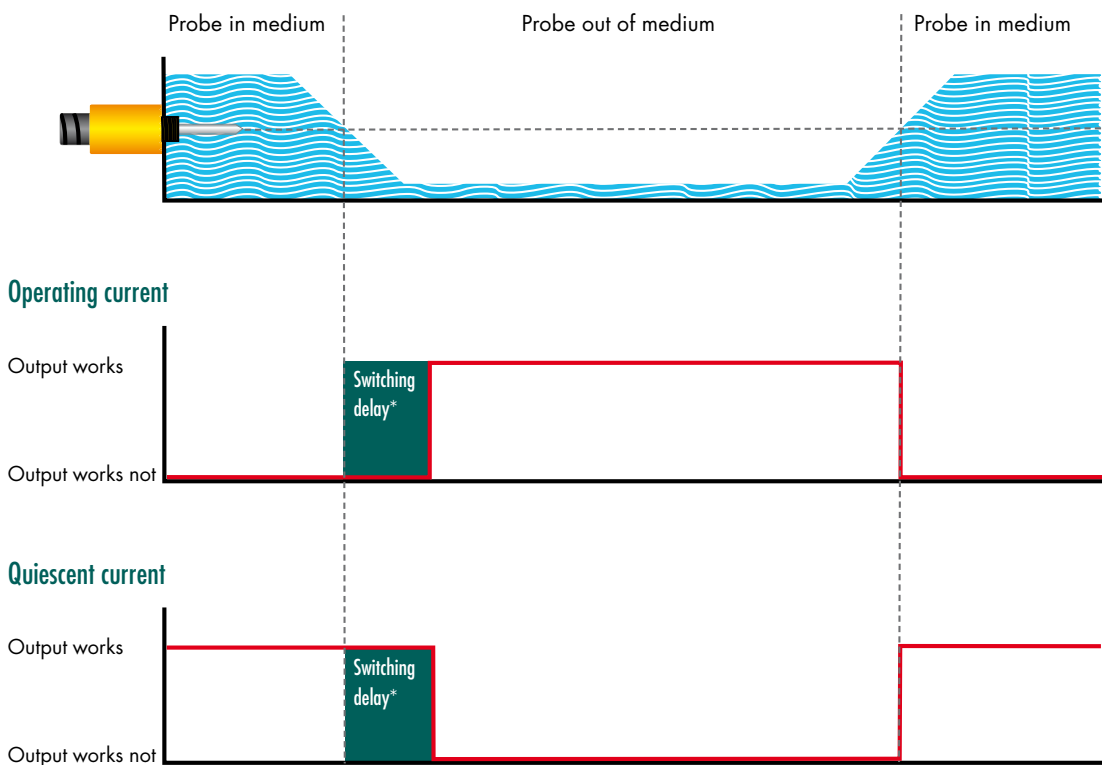

* If an immediately output switching is needed, it is possible to select a switching delay of 0 sec.

» Functionality overview

Level probes maximum

Level probes maximum

If a maximum probe is immersed in the medium, its outlet becomes active after the report delay. If it is a working current probe, its outlet becomes low-impedance after the report delay and a signal is available at the outlet. If it is a quiescent current probe, its outlet becomes high-impedance after the report delay and there is no longer a signal available at the outlet.

If a maximum probe is removed from the medium, its outlet immediately becomes passive. If it is a working current probe, its outlet becomes high-impedance after the removal and there is no longer a signal available at the outlet. If it is a quiescent current probe, its outlet becomes low-impedance after removal and a signal is available at the outlet.

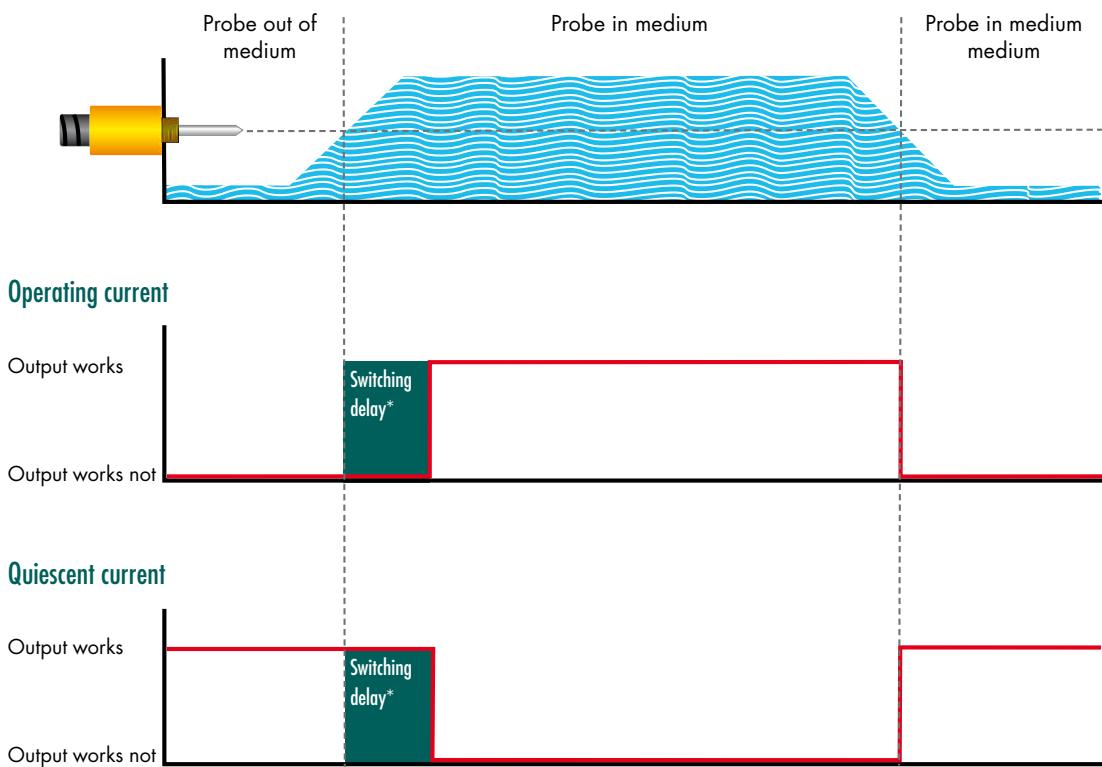

* If an immediately output switching is needed, it is possible to select a switching delay of 0 sec.

» Probe type PLS 40

sensor with connector bayonet DIN 72 585

Degree of protection IP 69K to DIN 40050

e1 type approval according EC-directive 2004/104/EC, UL approved
CE-marking according EC-directive 89/336/EWG (EMC-directive)

Thread	Monitoring display	Integral control function	Monitoring delay	Signal output – potential		Signal output + potential	
				Aqueous Liquids Ref.-No.	Oil and fuel Ref.-No.	Aqueous Liquids Ref.-No.	Oil and fuel Ref.-No.
Level sensors output OC, operating current							
M 14 x 1,5	MIN	2 sec	7 sec	420 400	420 431	420 401	420 432
M 14 x 1,5	MIN	0 sec	7 sec	–	420 446	–	–
M 14 x 1,5	MIN	0 sec	2 sec	420 419	420 447	–	–
M 14 x 1,5	MIN	2 sec	60 min	–	420 444	–	–
M 14 x 1,5	MIN	2 sec	60 sec	–	420 449	–	–
M 14 x 1,5	MIN	2 sec	7 sec	420 450	–	–	–
M 14 x 1,5	MIN	1 sec	17 sec	420 451	–	–	–
M 14 x 1,5	MIN	0 sec	0 sec	420 452	–	–	–
M 14 x 1,5	MAX	0 sec	0 sec	–	420 454	420 413	420 414
M 14 x 1,5	MAX	0 sec	7 sec	–	–	422 535	–
M 18 x 1,5	MIN	2 sec	7 sec	420 404	420 435	420 405	420 436
M 18 x 1,5	MIN	0 sec	7 sec	420 417	–	–	–
M 18 x 1,5	MAX	0 sec	0 sec	420 422	420 430	–	–
1/4" NPTF	MIN	2 sec	7 sec	420 408	420 439	420 409	420 440
1/4" NPTF	MIN	0 sec	7 sec	420 418	–	–	420 443
1/4" NPTF	MIN	1 sec	17 sec	420 415	–	–	–
1/4" NPTF	MIN	0 sec	0 sec	–	420 463	–	–
1/4" NPTF	MAX	2 sec	7 sec	–	420 456	–	–
1/4" NPTF	MAX	2 sec	0 sec	–	420 470	–	–
1/2" NPTF	MIN	2 sec	7 sec	422 541	–	–	–
G 3/8"	MAX	0 sec	7 sec	420 420	–	–	–
G 3/8"	MAX	0 sec	0 sec	420 416	–	–	–
G 3/8"	MAX	0 sec	0 sec	–	–	–	420 448
Probe with the sensing point 43mm from sensor tip							
M 14 x 1,5	MIN	1 sec	17 sec	420 412	–	–	–
Level sensors output RC, quiescent current							
M 14 x 1,5	MIN	0 sec	0 sec	420 467	–	–	–
M 14 x 1,5	MIN	0 sec	7 sec	420 402	420 433	420 403	420 434
M 14 x 1,5	MIN	0 sec	7 sec	–	–	–	420 428
M 18 x 1,5	MIN	0 sec	7 sec	420 406	420 437	420 407	420 438
3/8" NPTF	MIN	0 sec	0 sec	–	420 458	–	–
1/4" NPTF	MIN	0 sec	7 sec	420 410	420 441	420 411	420 442
R 1/2"	MIN	0 sec	7 sec	420 426	–	–	–



Accessories for probes with connector bayonet DIN 72585

Ref.-No.	Description			Connection
Connector				
420 700	Straight connector for bayonet DIN 72 585, for corrugated tubing NW10			
420 701	90° connector for bayonet DIN 72 585, for corrugated tubing NW 10			
420 702	Connector 90° for cable			
420 703	Straight connector for cable			
Cable with connector				
420 699	Cable with connector 420 703	150 mm		2*
420 704	Cable with connector 420 702	300 mm		2*
420 705	Cable with connector 420 703	300 mm		2*
420 706	Cable with connector 420 702	1000 mm		1*
420 707	Cable with connector 420 703	1000 mm		1*
420 708	Cable with connector 420 702	3000 mm		1*
420 709	Cable with connector 420 703	2000 mm		1*
420 714	Cable with connector 420 703	5000 mm		1*
420 715	Cable with connector 420 703	10000 mm		1*
420 716	Cable with connector 420 702	6000 mm		1*
420 717	Cable with connector 420 703	3000 mm		1*
420 718	Cable with connector 420 702	5000 mm		1*
420 719	Cable with connector 420 703	6000 mm		1*
Screw-in adapter				
421 639	Screw-in adapter	outside: R 1"	inside: M 18 x 1,5	
421 640	Screw-in adapter	outside: M 22 x 1,5	inside: M 14 x 1,5	
421 694	Screw-in adapter	outside: R 1/2"	inside: M 14 x 1,5	
421 695	Screw-in adapter	outside: G 1/2"	inside: M 14 x 1,5	
421 884	Screw-in adapter	outside: M 22 x 1,5	inside: 1/4" NPTF	
421 696	Screw-in adapter	outside: M 16 x 1,5	inside: M 14 x 1,5	
Brazed adapter				
421 641	Brazed adapter 1/4"NPTF			
421 644	Brazed adapter M 14 x 1,5			
421 648	Brazed adapter M 18 x 1,5			

1* Cable end without connector

2* Cable with 3 pole flat quick-connect terminations 6.3 in the housing

» Level probes type PLS 40

with cable

Degree of protection IP 69K to DIN 40050

e1 type approval according EC-directive 2004/104/EC,
CE-marking according EC-directive 89/336/EWG (EMC-directive)

Thread	Monitoring display	Integral control function	Monitoring delay	Cable length in mm	Cable Connection type	Signal output – potential		Signal output + potential	
						Aqueous Liquids Ref.-No.	Oil and fuel Ref.-No.	Aqueous Liquids Ref.-No.	Oil and fuel Ref.-No.
Level sensors output OC, operating current									
M 12 x 1	MIN	0 sec	7 sec	1000	1*	421 580	–	–	–
M 14 x 1,5	MIN	0 sec	7 sec	300	2*	421 519	–	–	–
M 14 x 1,5	MIN	2 sec	7 sec	250	1*	422 537	421 991	425 016	425 017
M 14 x 1,5	MIN	2 sec	7 sec	250	8*	421 927	421 928	–	–
M 14 x 1,5	MIN	2 sec	7 sec	2000	1*	–	421 929	–	–
M 14 x 1,5	MIN	2sec	7sec	300	2*	421 520	421 518	–	–
M 14 x 1,5	MIN	2 sec	7 sec	250	5*	–	421 072	–	–
M 14 x 1,5	MIN	2 sec	7 sec	250	9*	421 070	–	–	–
M 14 x 1,5	MIN	2 sec	7 sec	250	3*	–	422 525	–	–
M 14 x 1,5	MIN	2 sec	7 sec	2500	1*	422 297	422 298	–	–
M 14 x 1,5	MAX	0 sec	7 sec	250	5*	–	421 568	–	–
M 14 x 1,5	MIN	2 sec	7 sec	250	10*	418 154	–	–	–
M 14 x 1,5	MIN	0 sec	7 sec	500	3*	422 506	422 507	–	–
M 14 x 1,5	MIN	0 sec	2 sec	500	1*	–	421 507	–	–
M 14 x 1,5	MAX	0 sec	0 sec	1000	1*	–	–	425 300	425 301
M 14 x 1,5	MIN	2 sec	3 sec	250	9*	–	422 527	–	422 547
M 18 x 1,5	MIN	2 sec	7 sec	1000	1*	–	421 591	–	–
M 18 x 1,5	MIN	2 sec	7 sec	360	3*	422 515	–	–	–
M 18 x 1,5	MAX	2 sec	7 sec	360	3*	422 516	–	–	–
M 18 x 1,5	MIN	2 sec	7 sec	250	2*	422 503	422 504	425 020	425 021
M 18 x 1,5	MAX	0 sec	0 sec	1000	1*	425 305	425 304	–	–
1/4" NPTF	MIN	0 sec	0 sec	250	1*	421 566	421 567	–	–
1/4" NPTF	MIN	2 sec	7 sec	250	1*	421 402	421 992	425 024	425 025
1/4" NPTF	MIN	2 sec	7 sec	300	2*	421 521	421 523	–	–
1/4" NPTF	MIN	2 sec	7 sec	500	3*	422 225	422 226	–	–
1/4" NPTF	MIN	2 sec	7 sec	500	11*	422 524	–	–	–
1/4" NPTF	MIN	2 sec	7 sec	10000	1*	420 424	–	–	–
1/4" NPTF	MIN	0 sec	7 sec	500	3*	–	–	–	425 303
G 3/8"	MAX	0 sec	0 sec	360	3*	–	421 510	–	–
G 1/2"	MIN	2 sec	7 sec	250	9*	421 515	–	–	–
1/2" NPT	MIN	0 sec	0 sec	300	14*	–	–	–	422 531
1/2" NPT	MIN	2 sec	4 sec	300	14*	–	–	–	422 532
1/2" NPT	MIN	2 sec	7 sec	170	1*	422 540	–	–	–



Thread	Monitoring display	Integral control function	Monitoring delay	Cable length in mm	Cable Connection type	Signal output – potential		Signal output + potential	
						Aqueous Liquids Ref.-No.	Oil and fuel Ref.-No.	Aqueous Liquids Ref.-No.	Oil and fuel Ref.-No.
Level sensors output QC, quiescent current									
M 14 x 1,5	MIN	0 sec	7 sec	250	1*	421 582	421 993	425 018	425 019
M 14 x 1,5	MIN	0 sec	2 sec	220	5*	421 569	–	–	–
M 18 x 1,5	MIN	0 sec	7 sec	250	1*	–	–	425 022	425 023
1/4" NPTF	MIN	0 sec	7 sec	2000	1*	–	–	425 030	–
1/4" NPTF	MIN	0 sec	7 sec	250	1*	421 999	421 997	425 026	425 027
1/4" NPTF	MIN	0 sec	7 sec	250	4*	422 505	–	–	–
1/4" NPTF	MIN	0 sec	7 sec	500	3*	422 521	422 522	425 302	–
1/4" NPTF	MIN	0 sec	7 sec	250	16*	–	–	425 032	–
3/8" NPTF	MIN	0 sec	7 sec	250	1*	–	–	–	425 031
3/8" NPTF	MIN	0 sec	0 sec	180	15*	–	400 001	–	–
G 3/8"	MIN	0 sec	0 sec	2000	1*	422 534	422 533	–	–
G 3/8"	MIN	0 sec	7 sec	2000	1*	422 523	–	–	–
G 3/8"	MIN	0 sec	7 sec	250	1*	421 998	–	–	–
G 3/8"	MIN	0 sec	7 sec	250	3*	422 286	–	–	–
Probe with the sensing point at 35mm from sensor tip									
G 3/8"	MIN	0 sec	7 sec	2000	1*	422 523	–	–	–

(1*) Cable end without connector

(2*) Cable with 3 pole flat quick-connect

(3*) Cable with 3 pole DEUTSCH socket

(4*) Cable with 3 pole round G & H connector

(5*) Cable with 3 pole Reinshagen connector

(8*) Cable with 3 pole round AMP connector

(9*) Cable with 3 flat quick-connect terminations

(10*) Cable with 3 pole AMP connector

(11*) Probe 422 524 like the probe 422

(14*) Cable with Sure-Seal-connector

(15*) Cable with Packard connector

Accessories for probes with cable

Ref.-No.	Description	Connection
Screw-in adapter		
421 639	Screw-in adapter	outside: R 1" inside: M 18 x 1,5
421 640	Screw-in adapter	outside: M 22 x 1,5 inside: M 14 x 1,5
421 694	Screw-in adapter	outside: R 1/2" inside: M 14 x 1,5
421 695	Screw-in adapter	outside: G 1/2" inside: M 14 x 1,5
421 884	Screw-in adapter	outside: M 22 x 1,5 inside: 1/4" NPTF
421 696	Screw-in adapter	outside: M 16 x 1,5 inside: M 14 x 1,5
Braze-in adapter		
421 641	Braze-in adapter 1/4" NPTF	
421 644	Braze-in adapter M14 x 1,5	
421 648	Braze-in adapter M18 x 1,5	

» Level probes type PLS 40

sensor with connector bayonet 10 SL according VG 0095342

Degree of protection IP 67 to DIN 40050



e1 type approval according EC-directive 2004/104/EC,
CE-marking according EC-directive 89/336/EEG (EMC-directive)

Thread	Monitoring display	Integral control function	Monitoring delay	Signal output – potential		Signal output + potential	
				Aqueous Liquids Ref.-No.	Oil and fuel Ref.-No.	Aqueous Liquids Ref.-No.	Oil and fuel Ref.-No.
Level sensors output OC, operating current							
M 14 x 1,5	MIN	2 sec	7 sec	421 403	421 504	421 505	421 506
M 18 x 1,5	MIN	2 sec	7 sec	422 512	422 513	421 500	421 501
M 18 x 1,5	MIN	0 sec	0 sec	–	–	–	421 514
M 18 x 1,5	MAX	2 sec	7 sec	–	422 514	–	–
M 18 x 1,5	MAX	0 sec	0 sec	–	–	–	421 509
1/4" NPTF	MIN	2 sec	7 sec	421 907	421 908	421 498	421 499
1/2" UNF	MIN	2 sec	7 sec	–	421 584	–	–
Level sensors output QC, quiescent current							
M 14 x 1,5	MIN	0 sec	0 sec	–	–	421 508	–
M 14 x 1,5	MIN	0 sec	7 sec	–	–	–	421 516
M 18 x 1,5	MIN	0 sec	7 sec	421 989	421 990	421 502	421 503
1/4" NPTF	MIN	0 sec	7 sec	–	421 909	–	–

Accessories for probes with connector bayonet 10 SL			
Ref.-No.	Description		
Connector			
421 652	Straight connector for bayonet 10 SL according VG 0095342		
421 885	90° Connector for bayonet 10 SL 90° according VG 0095342		
Cable with connector			
421 653	Cable with connector straight	421 652	2000 mm
421 657	Cable with connector straight	421 652	5000 mm
421 658	Cable with connector straight	421 885	2000 mm
421 697	Cable with connector straight	421 885	5000 mm
Screw-in adapter			
421 639	Screw-in adapter	outside: R1"	inside: M 18 x 1,5
421 640	Screw-in adapter	outside: M 22 x 1,5	inside: M 14 x 1,5
421 694	Screw-in adapter	outside: R 1 1/2"	inside: M 14 x 1,5
421 695	Screw-in adapter	outside: G 1 1/2"	inside: M 14 x 1,5
421 884	Screw-in adapter	outside: M 22 x 1,5	inside: 1/4" NPTF
421 696	Screw-in adapter	outside: M 16 x 1,5	inside: M 14 x 1,5
Braze-in adapter			
421 641	Braze-in adapter	1/4" NPTF	
421 644	Braze-in adapter	M 14 x 1,5	
421 648	Braze-in adapter	M 18 x 1,5	

» Level probes type PLS 40

sensor with connector Packard

Degree of protection IP 67 to DIN 40050



e1 type approval according EC-directive 2004/104/EC,
CE-marking according EC-directive 89/336/EWG (EMC-directive)

Thread	Monitoring display	Integral control function	Monitoring delay	Signal output – potential		Signal output + potential	
				Aqueous Liquids Ref.-No.	Oil and fuel Ref.-No.	Aqueous Liquids Ref.-No.	Oil and fuel Ref.-No.
Level sensors output OC, operating current							
M 14 x 1,5	MIN	2 sec	7 sec	420 551	420 552	420 553	420 554
M 14 x 1,5	MAX	0 sec	0 sec	420 555	420 556	420 557	420 558
M 18 x 1,5	MIN	2 sec	7 sec	420 563	420 564	420 565	420 566
M 18 x 1,5	MAX	0 sec	0 sec	420 567	420 568	420 569	420 570
1/4" NPT	MIN	2 sec	7 sec	420 576	420 577	420 578	420 579
1/4" NPT	MAX	0 sec	0 sec	420 580	420 581	420 582	420 583
3/8" NPT	MIN	2 sec	7 sec	420 590	420 591	420 592	420 593
3/8" NPT	MAX	0 sec	0 sec	420 594	420 595	420 596	420 597

» Level probes type PLS 40

with connector according DIN 43650

Degree of protection IP 65 to DIN 40050



e1 type approval according EC-directive 2004/104/EC,
CE-marking according EC-directive 89/336/EWG (EMC-directive)

Thread	Monitoring display	Integral control function	Monitoring delay	Signal output – potential		Signal output + potential	
				Aqueous Liquids Ref.-No.	Oil and fuel Ref.-No.	Aqueous Liquids Ref.-No.	Oil and fuel Ref.-No.
Level sensors output OC, operating current							
M 14 x 1,5	MIN	2 sec	7 sec	420 600	420 620	420 601	420 621
M 18 x 1,5	MIN	2 sec	7 sec	420 604	420 624	420 605	420 625
1/4" NPTF	MIN	2 sec	7 sec	420 608	420 628	420 609	420 629
R 3/8"	MAX	0 sec	0 sec	–	420 632	–	420 650
Level sensors output QC, quiescent current							
M 14 x 1,5	MIN	0 sec	7 sec	420 602	420 622	420 603	420 623
M 18 x 1,5	MIN	0 sec	7 sec	420 606	420 626	420 607	420 627
1/4" NPTF	MIN	0 sec	7 sec	420 610	420 630	420 611	420 631

Accessories for probes with connector DIN 43650

Ref.-No.	Description
Connector	
421 880	Connector M 3 x 35 according DIN 43 650
Screw-in adapter	
421 639	Screw-in adapter outside: R 1" inside: M 18 x 1,5
421 640	Screw-in adapter outside: M 22 x 1,5 inside: M 14 x 1,5
421 694	Screw-in adapter outside: R 1/2" inside: M 14 x 1,5
421 695	Screw-in adapter outside: G 1/2" inside: M 14 x 1,5
421 884	Screw-in adapter outside: M 22 x 1,5 inside: 1/4" NPTF
421 696	Screw-in adapter outside: M 16 x 1,5 inside: M 14 x 1,5
Braze-in adapter	
421 641	Braze-in adapter 1/4" NPTF
421 644	Braze-in adapter M 14 x 1,5
421 648	Braze-in adapter M 18 x 1,5

» Level probes type PLS 40

with connector thread M 27 x 1

Degree of protection IP 67 to DIN 40050



e1 type approval according EC-directive 2004/104/EC,
CE-marking according EC-directive 89/336/EWG (EMC-directive)

Thread	Monitoring display	Integral control function	Monitoring delay	Type	Signal output – potential	
					Aqueous Liquids Ref.-No.	Oil and fuel Ref.-No.
Level sensors output OC, operating current						
M 14 x 1,5	MIN	2 sec	7 sec		421 603	421 623
M 14 x 1,5	MIN	2 sec	7 sec	1*	–	422 293
M 14 x 1,5	MIN	0 sec	7 sec		–	421 634
M 14 x 1,5	MIN	2 sec	20 sec		421 617	–
1/4" NPTF	MIN	2 sec	7 sec		421 607	421 627
Level sensors output QC, quiescent current						
M 14 x 1,5	MIN	0 sec	7 sec	2*	–	422 299
M 14 x 1,5	MIN	0 sec	7 sec		421 611	421 631

1* Housing nickel plated

2* Probe with the sensing point at 15 mm from sensor tip, housing nickel plated

Accessories for probes with connector thread M27 x 1

Ref.-No.	Description			Connection
Connector				
421 642	Straight connector M 27 x 1 for corrugated tubing NW 10			
421 643	90° connector M 27 x 1 for corrugated tubing NW 10			
421 742	Straight connector M 27 x 1 with 5,6 mm cable sealing			
421 743	90° connector M 27 x 1 with 5,6 mm cable sealing			
Cable with connector				
421 988	Cable with connector straight	421 742	300 mm	2*
421 588	Cable with connector 90°	421 743	300 mm	2*
421 038	Cable with connector 90°	421 743	300 mm	1*
Screw-in adapter				
421 639	Screw-in adapter	outside: R1"	inside: M 18 x 1,5	
421 640	Screw-in adapter	outside: M 22 x 1,5	inside: M 14 x 1,5	
421 694	Screw-in adapter	outside: R 1/2"	inside: M 14 x 1,5	
421 695	Screw-in adapter	outside: G 1/2"	inside: M 14 x 1,5	
421 884	Screw-in adapter	outside: M 22 x 1,5	inside: 1/4" NPTF	
421 696	Screw-in adapter	outside: M 16 x 1,5	inside: M 14 x 1,5	
Braze-in adapter				
421 641	Braze-in adapter	1/4" NPTF		
421 644	Braze-in adapter	M 14 x 1,5		
421 648	Braze-in adapter	M 18 x 1,5		

1* Cable end without connector

2* Cable end with 3 pole flat quick-connect terminations 6.3x0.8 in the housing

» Level probes type 40

sensor with connector bayonet 16 S

Degree of protection IP 67 to DIN 40050

e1 type approval according EC-directive 2004/104/EC,
CE-marking according EC-directive 89/336/EWG (EMC-directive)

Thread	Monitoring display	Integral control function	Monitoring delay	Signal output – potential		Signal output + potential	
				Aqueous Liquids Ref.-No.	Oil and fuel Ref.-No.	Aqueous Liquids Ref.-No.	Oil and fuel Ref.-No.
Level sensors output OC, operating current							
M 12 x 1	MIN	2 sec	7 sec	421 404	421 593	–	–
M 14 x 1,5	MIN	2 sec	7 sec	421 575	421 595	425 002	425 003
M 14 x 1,5	MIN	1 sec	17 sec	–	420 445	–	–
M 14 x 1,5	MAX	0 sec	0 sec	–	422 511	–	–
M 14 x 1,5	MIN	0 sec	0 sec	422 528	422 529	–	–
M 14 x 1,5	MAX	2 sec	2 sec	–	422 509	–	–
M 14 x 1,5	MIN	2 sec	15 sec	421 637	–	–	–
M 14 x 1,5	MIN	2 sec	2 sec	422 502	422 508	–	422 510
M 14 x 1,5	MIN	0 sec	7 sec	421 564	421 590	–	–
M 14 x 1,5	MAX	0 sec	2 sec	–	–	425 004	–
M 14 x 1,5	MIN	2 sec	0 sec	–	421 562	–	–
M 18 x 1,5	MIN	2 sec	7 sec	421 570	421 572	425 006	425 007
M 18 x 1,5	MIN	0 sec	7 sec	–	422 031	–	–
1/4" NPTF	MIN	2 sec	7 sec	421 577	421 597	425 010	425 011
1/4" NPTF	MIN	2 sec	15 sec	421 401	–	–	–
1/4" NPTF	MIN	0 sec	7 sec	421 581	–	425 000	–
1/4" NPTF	MIN	0 sec	20 sec	421 636	–	–	–
1/4" NPTF	MIN	6 sec	15 sec	422 500	–	–	–
1/4" NPTF	MIN	0 sec	0 sec	–	–	–	–
3/8" NPTF	MIN	2 sec	7 sec	420 992	420 994	425 014	425 015
3/8" NPTF	MIN	0 sec	7 sec	–	–	–	425 001
Probe with sensing point at 25mm from sensor tip							
M 22 x 1,5	MIN	1 sec	17 sec	422 501	–	–	–
Probe with housing nickl plated							
M 14 x 1,5	MIN	2 sec	7 sec	421 513	–	–	–
Level sensors output QC, quiescent current							
M 12 x 1,5	MIN	2 sec	7 sec	421 400	–	–	–
M 14 x 1,5	MIN	0 sec	7 sec	421 579	421 599	–	425 005
M 18 x 1,5	MIN	0 sec	7 sec	421 571	421 573	425 008	425 009
1/4" NPTF	MIN	0 sec	7 sec	420 993	424 999	425 013	425 012
3/8" NPTF	MIN	0 sec	7 sec	–	–	–	425 029



Accessories for probes with connector bayonet 16 S

Ref.-No.	Description	Connection		
Connector				
421 672	Straight connector for bayonet 16 S, for corrugated tubing NW10			
421 673	90° connector for bayonet 16 S, for corrugated tubing NW 10			
421 772	Straight connector for bayonet 16 S with 5,6 mm cable sealing			
421 773	90° connector for bayonet 16 S with 5,6 cable sealing			
Cable with connector				
421 670	Cable with connector straight	421 772	300 mm	2*
421 871	Cable with connector straight	421 772	500 mm	13*
421 891	Cable with connector straight	421 772	800 mm	2*
421 018	Cable with connector straight	421 772	1015 mm	2*
421 586	Cable with connector straight	421 772	1300 mm	2*
421 668	Cable with connector straight	421 772	3000 mm	2*
421 775	Cable with connector straight	421 772	5000 mm	2*
421 774	Cable with connector straight	421 772	15000 mm	2*
421 671	Cable with connector 90°	421 773	300 mm	2*
421 017	Cable with connector 90°	421 673	300 mm	12*
421 585	Cable with connector 90°	421 773	1300 mm	2*
421 669	Cable with connector 90°	421 773	5000 mm	1*
421 587	Cable with connector 90°	421 773	10000 mm	12*
Screw-in adapter				
421 639	Screw-in adapter	outside: R1"	inside: M 18 x 1,5	
421 640	Screw-in adapter	outside: M 22 x 1,5	inside: M 14 x 1,5	
421 694	Screw-in adapter	outside: R 1/2"	inside: M 14 x 1,5	
421 695	Screw-in adapter	outside: G 1/2"	inside: M 14 x 1,5	
421 884	Screw-in adapter	outside: M 22 x 1,5	inside: 1/4" NPTF	
421 696	Screw-in adapter	outside: M 16 x 1,5	inside: M 14 x 1,5	
Braze-in adapter				
421 641	Braze-in adapter	1/4" NPTF		
421 644	Braze-in adapter	M 14 x 1,5		
421 648	Braze-in adapter	M 18 x 1,5		

1* Cable end without connector

2* Cable end with 3 pole flat quick-connect terminations 6.3x0.8 in the housing

12* Cable end without housing with flat quick-connect terminations 6.3x0.8

13* Cable end with Deutsch connector DT 04-3P

» Technical data

for Level probes type PLS 40
at $T_u = 25\text{ °C}$

Operating voltage:	DC 12/24 V (-25 %/+50 %)
Current consumption:	typ. 8 mA
Signal output switching current	1 A over the whole operating voltage range. At inductive loads freewheeling diode e.g. 1N4007, has to be mounted at the load.
Switch point vertically mounted:	20 mm ± 6 mm
Switch point horizontally mounted:	2,5 mm ± 1 mm
Switch point hysteresis:	typ. < 3 mm
Medium temperature:	-30 °C ... +125 °C
Ambient temperature:	-30 °C ... +125 °C
Storage temperature:	-50 °C ... +125 °C
Response delay:	see product table on following pages
Integral control function:	see product table on following pages
Reverse polarity protection:	see product table on following pages
Function:	see product table on following pages

Caution!

With **low-side switching** sensors do not connect minus potential to signal terminal and plus potential to minus terminal.

With **high-side switching** sensors do not connect plus potential to signal terminal and minus potential to plus terminal.

Voltage drop:	< 200 mV/1 A			
Vibration:	IEC 68-2-6 5–57 Hz 1,5 mm/58–200 Hz 20 g			
	Cab	5 Hz	0.007 g ² Hz	
		20 Hz	0.07 g ² Hz	
		100 Hz	0.007 g ² Hz	
		300 Hz	0.007 g ² Hz	
		2000 Hz	0.0035 g ² Hz	
	Frame	20 Hz	0.001 g ² Hz	797 Hz 0.10 g ² Hz
		119 Hz	0.08 g ² Hz	1212 Hz 0.001 g ² Hz
		223 Hz	0.011 g ² Hz	1780 Hz 0.0005 g ² Hz
		391 Hz	0.091 g ² Hz	1980 Hz 0.0004 g ² Hz
Pressure resistance:	25 bar = 367,5 PSI			
Environmental protection:	see product table on following pages			
Mounting attitude:	optional			
Housing:	typ. CuZn38Pb1,5 material number 2.0371 capacitive connected to ground Tefzel® ETFE			
Probe coating:	Tefzel® ETFE			
Weight:	approx. 120g			
Mounting thread:	see product table on following pages			
Marking:	Laser EMV			
Electrostatic discharge:	IEC 1000-4-2	8 kV air discharge 6 kV contact discharge		
Radiated electro-magnetic fields:	IEC 1000-4-3	30 V/m; 27 MHz to 1000 MHz 80% AM (1kHz)		
Burst:	IEC 1000-4-4	2 V power supply 1 kV signal output		
Surge:	IEC 1000-4-5	0.5 kV power supply 1 kV, signal output		
Conducted high frequency:	IEC 1000-4-6	10 V; 10 kHz to 80 MHz 80% AM (1kHz)		

» Level probes type PLS 45



Probe for aqueous liquids



Probe for oily liquids

e1 type approval according EC-directive 2004/104/EC,
CE-marking according EC-directive 89/336/EWG (EMC-directive)

Technical description

The Level sensor PLCA 55 is working with 5 V DC supply voltage. They operate in the principle of electrical capacitance changes arising when an electrode surrounded by air is immersed in a liquid medium. This capacitance change causes the electrical circuit at the sensor electrode to oscillate (approx. 600 kHz); the resultant signal is processed in the digital control unit.

For further questions and to order sensor please contact us:

Tel. +49 (0) 9187 95 09 611
Fax +49 (0) 9187 95 09 1611
vertrieb@bedia.com

» Technical data

for Level probes type PLS 45

at $T_u = 25\text{ °C}$

Voltage rating:	DC 5 V ($\pm 0,25$ V)
Current consumption:	typ. 8 mA
Signal output:	voltage
At $-30\text{ °C} \dots 125\text{ °C}$:	0,5 V and 4,5 V; 0,4 V ... 0,6 V; 4,4 V ... 4,6 V at 10 mA
Wire break detection:	
GND:	> 4,84 V
SIGNAL:	< 0,20 V
U_B :	< 0,20 V
Output current:	< 10 mA short-circuit and overload protected over the ambient temperature range
Switch point vertically mounted:	18 mm \pm 6 mm
Switch point horizontally mounted:	2,5 mm \pm 1 mm
Switch point hysteresis:	typ. < 3 mm
Medium temperature:	$-30\text{ °C} \dots +125\text{ °C}$
Ambient temperature:	$-30\text{ °C} \dots +125\text{ °C}$
Storage temperature:	$-50\text{ °C} \dots +125\text{ °C}$
Function:	see ordering information
Reverse polarity protection:	in-built between plus and minus terminal
Vibration:	IEC 68-2-6 5–57 Hz 1,6 mm Amplitude; 57–2000 Hz 4 g
Pressure resistance:	25×10^5 Pa (25 bar = 367,5 PSI)
Degree of protection:	see on following pages
Mounting attitude:	optional
Housing:	capacitively connected to ground
Material:	Messing – CuZn38Pb1,5 galvanic nickel plated Probe coating: Tefzel® ETFE
Weight:	approx. 180 g
Mounting thread:	see ordering information
Marking:	laser
Connection turning moment:	max. 50 Nm
EMC Electrostatic discharge:	IEC 1000-4-2 8 kV air discharge; 6 kV contact discharge
Radiated electro-magnetic fields:	IEC 1000-4-3 30 V/m; 20 MHz ... 1000 MHz; 80% AM (1 kHz)
Burst:	IEC 1000-4-4 1 kV capacitive coupling
Conducted high frequency:	IEC 1000-4-6 10 V; 10 kHz ... 80 MHz; 80 % AM (1 kHz)
Conducted emissions:	CISPER 16-1,2 30 kHz ... 75 kHz 54 dB ... 44 dB (μ V/m); 75 kHz ... 400 kHz 44 dB ... 55 dB (μ V/m); 400 kHz ... 1000 MHz 55 dB (μ V/m)
Radiated emissions from enclosure port:	CISPER 16-1,2 30 kHz ... 75 kHz, 64 dB ... 54 dB (μ V/m); 75 kHz ... 400 MHz 54 dB ... 65 dB (μ V/m); 400 MHz ... 1000 MHz 65 dB (μ V/m)

» Special accessoires

for level probes type PLS 40 and type PLS 45



Suggestion for level monitoring in the oil sump

Which are the benefits of a level monitoring system in the oil sump over conventional pressure and temperature sensors?

Temperature sensors indicate very slowly. When motor oil is lost, e. g. by tubing breakage, the component temperature can no longer be conducted to the sensors.

The lower limit value of oil pressure switches or sensors is set low (low oil pressure, with the motor running at no load). At rated motor speed and with too little oil in the oil circuit an oil-air mixture may be produced without that a signal is put out. The components are no longer sufficiently cooled and lubricated.

In the two events described above, the output signal is available either too late or even not at all so that the motor will be damaged. The level monitoring system, however, indicates even before the oil level becomes too low, i.e. as soon as the oil level has fallen 10 to 20 mm below the minimum marking on the dipstick. Oil pressure and oil temperature indication is always ensured.

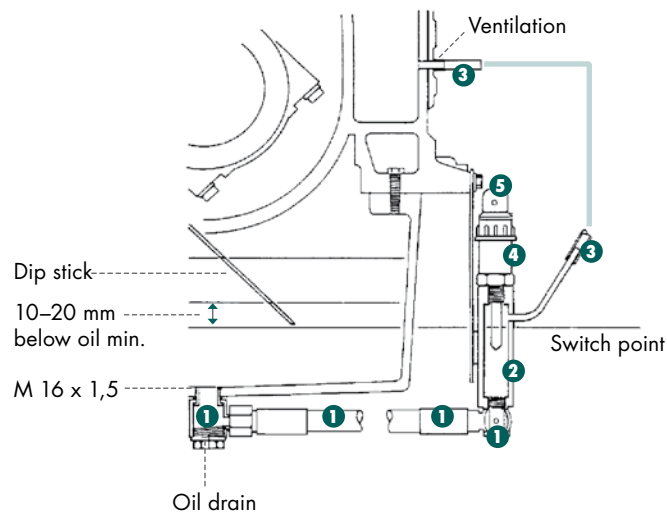

Special accessories for level probes type PLS 40 and type PLS 45

Bestell-Nr.	Beschreibung	Picture-Nr. (see illustration)	
421 660	Tubing complete with 350 mm pipe coupling	1	
421 661	Tubing complete with 450 mm pipe coupling	1	
421 659	Tubing complete with 550 mm pipe coupling	1	
454 134	Sensor support	2	
421 662	PA pipe, available in meters	3	
420 431	Level monitoring sensor	Oil MIN 9–36 V	4
420 454	Level monitoring sensor	Oil MAX 9–36 V	4
420 703	Straight connector without cable	5	
420 702	90° connector without cable	5	
420 707	Straight connector with cable	5	
420 706	90° connector with cable	5	

Installation instructions

1. Drain the motor oil.
2. Fasten adjustable corner swivelling screw-fitting to the engine with hose line and sensor bracket. The sensor holder has to be adjustable by the slots to determine the minimum point.
3. Install the ventilation to the crankcase (such as inspection hole cover)
4. Install and connect the sensor.
5. Check for correct electrical function. The minimum sensor must indicate now.
6. Refill the oil up to the minimum marking on the dip stick.
7. Move the sensor and support slowly down until the signal is no longer available. The switch point of the sensor is now exactly at the minimum oil level of the motor
8. Move the sensor down by another 10 to 20 mm and fix it. The signal „oil level too low“ will now be put out when the level is approx. 10 to 20 mm below the minimum marking on the dipstick.

» Level probes type PLS 30

sensor with connector bayonet 10 SL according VG 0095342

Degree of protection IP 67 to DIN 40050



Thread	Monitoring display	Integral control function	Monitoring delay	Signal output – potential		Signal output + potential	
				Aqueous Liquids Ref.-No.	Oil and fuel Ref.-No.	Aqueous Liquids Ref.-No.	Oil and fuel Ref.-No.
Level sensors output OC, operating current							
M 18 x 1,5	MIN	1 sec	3 sec	421 903	421 950	421 470	421 471
M 18 x 1,5	MAX	1 sec	3 sec	421 951	421 952	421 472	421 473

Probe type PLS 30 with connector bayonet 10 SL to VG 0095342			
Order Nr.	Description		
Connector			
421 652	Straight connector for bayonet 10 SL		
421 885	90° connector for bayonet 10 SL		
Cable end with connector			
421 653	Cable end with connector	421 652	2000 mm
421 657	KCable end with connector	421 652	5000 mm
Braze-in adapter			
421 648	Braze-in adapter, internal thread M 18 x 1,5		

» Level probes type PLS 30

sensor with cable and connector bayonet 10 SL according VG 0095342

Degree of protection IP 68 to DIN 40050

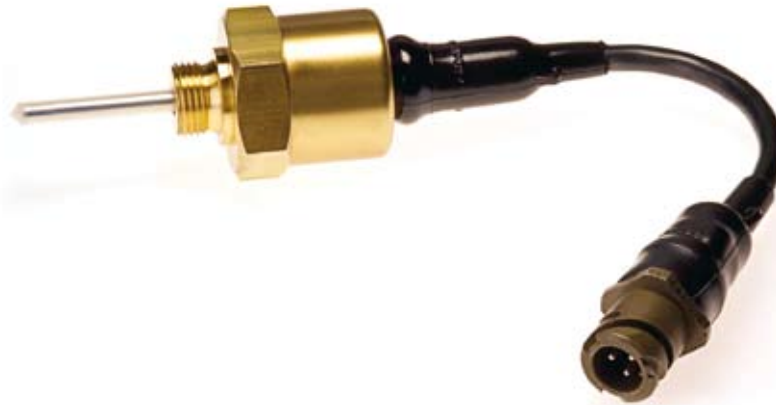

Thread	Monitoring display	Integral control function	Monitoring delay	Cable length in mm	Signalausgang – Potential		Signalausgang + Potential	
					Aqueous Liquids Ref.-No.	Oil and fuel Ref.-No.	Aqueous Liquids Ref.-No.	Oil and fuel Ref.-No.
Level sensors output OC, operating current								
M 18 x 1,5	MIN	1 sec	3 sec	200	421 906	421 957	421 478	421 479
M 18 x 1,5	MAX	1 sec	3 sec	200	421 958	421 959	421 480	421 481
M 18 x 1,5	MIN	1 sec	3 sec	450	421 960	–	–	–
M 18 x 1,5	MIN	1 sec	3 sec	550	421 962	–	–	–

» Technical data

for Level probes type PLS 30
at $T_u = 25\text{ °C}$

Mechanical data

Housing:	stainless, non-magnetic
Thread:	M 18 x 1,5, max. tightening torque 30 Nm
Sealing ring (not supplied with the system):	18 x 22 DIN 7603-CU
Fitting:	Cu-Zn alloy material No. 2.0401
Connection:	see table according to VG 0095342
Isolation of sensor::	Tefzel ETFE®
Marking:	function, type number, manufacturing date, voltage
Mounting attitude:	optional
Switch point:	immersion depth, horizontal: approx. 3 mm ± 2 mm immersion depth, vertical: approx. 20 mm ± 6 mm
Weight:	approx. 200 g
Ambient temperature:	-30°C ... + 125°C
Storage temperature:	-55°C ... + 125°C
Medium temperature:	-30°C ... + 125°C
Sinusoidal vibration (peak):	2-25 Hz 1,6 mm amplitude 25-420 Hz 4 g amplitude 420-1330 Hz 5 g amplitude 1330-2700 Hz 10 g amplitude 2700-5000 Hz 25 g amplitude
Relative humidity:	up to 100 %

Environment

Shock (peak):	50 g half-sine 11 ms
EMC:	IEC801(1-4) < 500 mV rms, depending on cables
EMC to VG 95373:	depending on cables
Interference suppression:	according to VDE0871, limit B
Pressure on sensor:	max. 25 bar/367,5 PSI
Media to be monitored:	water, cooling water, seawater, oil, fuel, hydraulic oil, brake fluid
Dependability:	The performance is not impaired by small deposits on the probe

Electric data

Voltage rating:	9–36 V
Output:	open collector, switching minus potential
Closed-circuit current at 24 V:	< 10 mA
Power consumption:	closed-circuit current plus switching current
Switching capacity:	max. 1 A continuous current in the voltage range indicated
Load:	resistive and inductive
Load inductance:	500 mH
Protection against reverse polarity:	between UB and frame
Voltage spikes:	70 V dropping to U_N in 270
Hysteresis of response:	max. ± 5 mm around the sensing point
Response time – "level acceptable":	typically 1 s (0,5 s to 1,5 s)
Response time – "level unacceptable":	typically 3 s (1 s to 4 s)
Recovery time:	< 2 s
Integral control function:	see table
Terminal connection:	A = + U_B B = - U_B C = output signal
Potential of housing:	galvanically isolated from plus U_B and minus U_B VDE
Dielectric strength:	according to VDE 0100.500, VDC 1 min
Insulation resistance:	according to VDE 0160.500, VAC/50 Hz, 1 min
Dielectric resistance:	> 10 M Ohm
Through connection voltage:	< 0, 5 V

Caution!

With **low-side switching** sensors do not connect minus potential to signal terminal and plus potential to minus terminal.

With **high-side switching** sensors do not connect plus potential to signal terminal and minus potential to plus terminal.

Inductive loads: A free wheeling diode, e.g. 1N4007, has to be mounted at the load