

TECHNICAL DATASHEET

Sine-wave Encoder S 21



- Wide operating temperature range of -15 °C up to $+120\text{ °C}$, therefore optimum use of motor capacity
- High limiting frequency with excellent signal quality, allowing highest peak speeds and reduced non-productive time wastage
- Excellent immunity to interference (EN 61000-4-4, Class 4)
- High functional safety due to signal control and system monitoring (under-voltage, pollution, disc damage, end of LED service life)
- High signal quality through control and error compensation



TECHNICAL DATA mechanical

Housing diameter	53 mm
Shaft diameter	Cone 1/10
Protection class shaft input (EN 60529)	IP40
Protection class housing (EN 60529)	IP40
Shaft load axial / radial	for tapered solid shaft: 20 N / 90 N
Axial endplay of mounting shaft (hubshaft)	$\pm 0.5\text{ mm}$
Radial runout of mating shaft (hubshaft)	$\pm 0.1\text{ mm}$
Max. speed	max. 12 000 rpm (continuous), max. 15 000 rpm (short term)
Torque	$\leq 1\text{ Ncm}$
Vibration resistance (DIN EN 60068-2-6)	$\leq 100\text{ m/s}^2$ (10 ... 2,000 Hz)
Shock resistance (DIN EN 60068-2-27)	$\leq 1,000\text{ m/s}^2$ (6 ms)
Operating temperature	$-15\text{ °C} \dots +120\text{ °C}$
Storage temperature	$-20\text{ °C} \dots +80\text{ °C}$
Material housing	Aluminum
Weight	approx. 170 g
Connection	PCB connector and cable

TECHNICAL DATA electrical

General design	as per DIN EN 61010-1, protection class III, contamination level 2, overvoltage class II
Supply voltage	DC 5 V $\pm 10\%$
Max. current w/o load	120 mA
Reference signal R	$> 0.4\text{ V}$ (1 pulse per revolution)
Commutation signals C, D	Sine - Cosine 1 Vpp (1 period per rev.)
Incremental signals optional	Sinus-Cosinus 1 Vpp
Number of pulses	2048
3dB limiting frequency	500 kHz
Absolute accuracy	$\pm 35''$
Repeatability	$\pm 7''$

TECHNICAL DATASHEET

Sine-wave Encoder S 21

S 21 SIGNALS

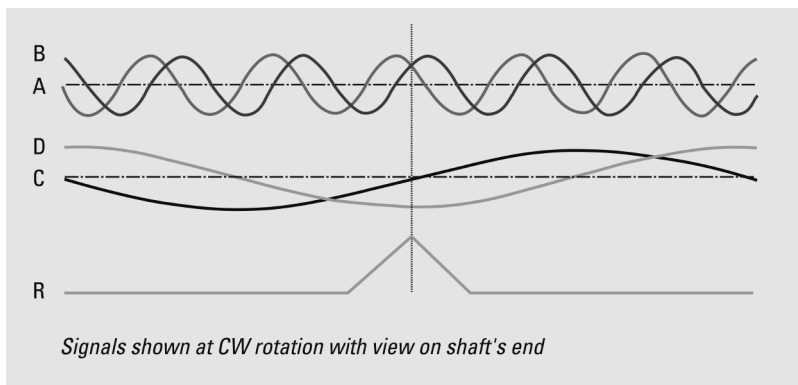

The incremental signals A and B and the zero signal R are differential voltage signals. The differential signal level is 1 Vpp. The zero signal appears once per revolution and reaches its maximum value at the angle where the amplitudes of A and B Signals are equal. The coarse tracks C and D deliver one sinewave period per revolution and are utilized to determine the absolute rotor position of Brushless DC motors for startup commutation. All signals have a DC offset of 2.5 V.

S 21 SIGNAL QUALITY

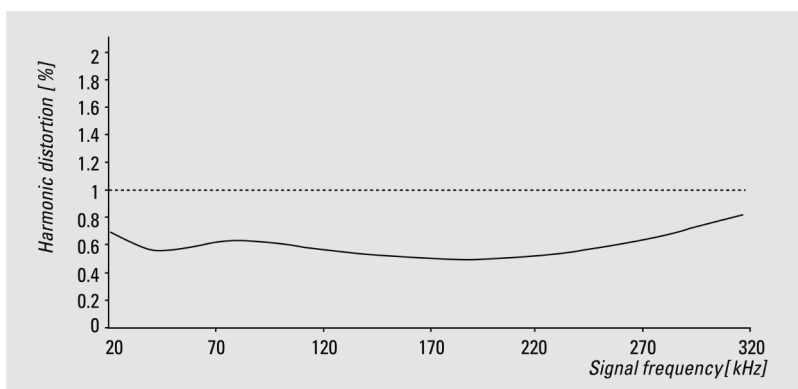

The quality of the servo loop is determined to a large extent by the absence of harmonics in the encoder's sinewave signals, particularly at low speed. In order to achieve high interpolation factors in the sequencing control, the incremental sinewave signals A and B are available with a harmonic distortion significantly under 1% throughout the specified temperature range. This delivers excellent synchronism and a high level of positional accuracy with servo axes.

TECHNICAL DATASHEET

Sine-wave Encoder S 21

ELECTRICAL CONNECTIONS PCB connector

Colour	PIN	Signals
brown	1a	C-
grey/pink	1b	U _B
yellow	2a	A-
black	2b	D+
green/brown	3a	0 V Sense
blue	3b	B+
pink	4a	R-
grey	4b	R+
red	5a	B-
white/green	5b	GND
violet	6a	D-
green	6b	A+
red/blue	7a	DC 5 V Sense
white	7b	C+

DIMENSIONED DRAWINGS

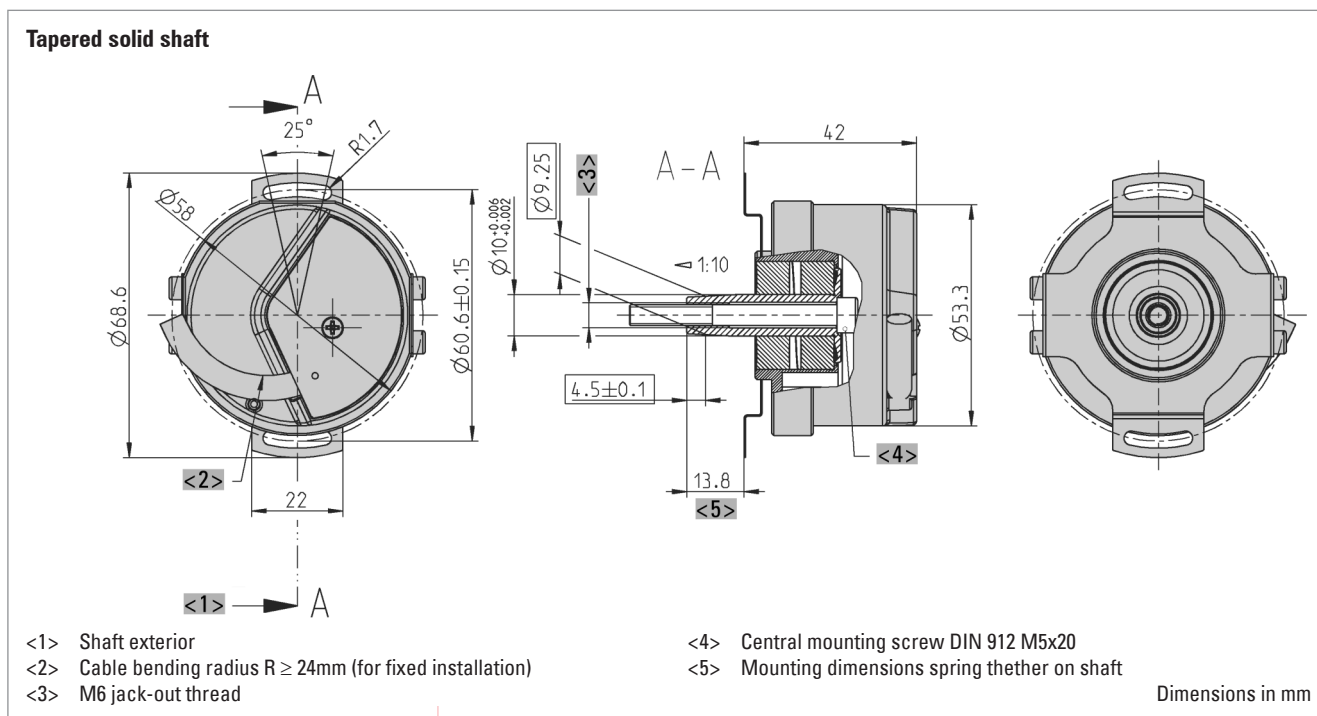

ORDERING INFORMATION

	Ordering code
Tapered solid shaft with mounting support	0 548 011

TECHNICAL DATASHEET

**Sine-wave Encoder S 21
Accessories**