

RES-407

®

Operating Instructions

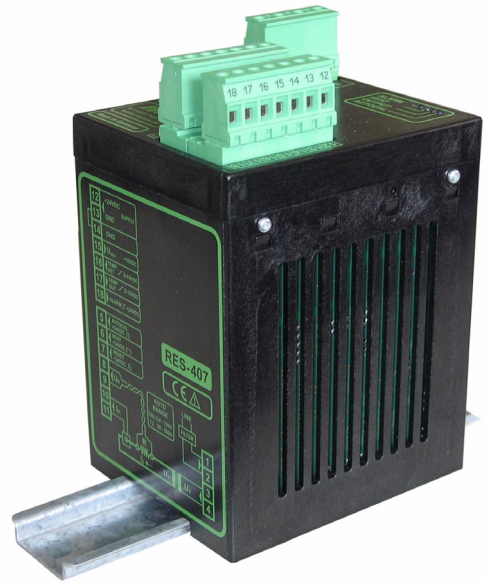

Important features

- Microprocessor technology
- Automatic zero calibration (AUTOCAL)
- Automatic optimization (AUTOTUNE)
- Automatic configuration of the secondary voltage and current ranges (AUTORANGE, as of April 2005)
- Automatic phase angle compensation (AUTOCOMP, as of April 2005)
- Automatic frequency adjustment
- Large current and voltage range
- Electrically isolated analog input for set point selection with potentiometer or 0...10VDC
- Electrically isolated 0...10VDC analog output for ACTUAL temperature
- 24VDC control signals for START, AUTOCAL and RESET with electrical isolation
- Alarm function with fault diagnosis
- Heatsealing band alloy and temperature range selectable as standard (as of June 2003)

Contents

| | | | | | |
|----------|---|-----------|-----------|--|-----------|
| 1 | Safety and warning notes | 3 | 9 | Startup and operation | 19 |
| 1.1 | Use | 3 | 9.1 | View of the controller | 19 |
| 1.2 | Heatsealing band | 3 | 9.2 | Controller configuration | 19 |
| 1.3 | Impulse transformer | 3 | 9.3 | Heatsealing band | 21 |
| 1.4 | Current transformer PEX-W2/-W3 | 3 | 9.4 | Startup procedure | 22 |
| 1.5 | Line filter | 4 | 10 | Controller functions | 24 |
| 1.6 | Warranty provisions | 4 | 10.1 | Indicators and controls | 24 |
| 1.7 | Standards / CE marking | 4 | 10.2 | Temperature setting (set point selection) | 25 |
| 2 | Application | 4 | 10.3 | Temperature indication (actual value output) | 26 |
| 3 | Principle of operation | 5 | 10.4 | Automatic zero calibration (AUTOCAL) | 27 |
| 4 | Description of the controller | 6 | 10.5 | "START" signal (HEAT) | 28 |
| 5 | Accessories and modifications | 6 | 10.6 | "RESET" signal | 28 |
| 5.1 | Accessories | 6 | 10.7 | Measuring impulse duration (as of April 2005) | 29 |
| 5.2 | Modifications (MODs) | 7 | 10.8 | Automatic phase angle compensation (AUTOCOMP) (as of April 2005) | 29 |
| 6 | Technical data | 10 | 10.9 | Temperature diagnosis (as of April 2005) | 30 |
| 7 | Dimensions | 12 | 10.10 | Heatup timeout (as of April 2005) | 31 |
| 8 | Installation | 12 | 10.11 | Diagnostic interface/visualization software (as of April 2005) | 31 |
| 8.1 | Installation procedure | 12 | 10.12 | System monitoring/alarm output | 31 |
| 8.2 | Installation steps | 13 | 10.13 | Error messages | 32 |
| 8.3 | Power supply | 14 | 10.14 | Fault areas and causes | 37 |
| 8.4 | Line filter | 15 | 11 | Factory settings | 38 |
| 8.5 | Current transformer PEX-W3 | 15 | 12 | Maintenance | 39 |
| 8.6 | Auxiliary voltage | 16 | 13 | How to order | 40 |
| 8.7 | Wiring diagram (standard) | 16 | 14 | Index | 42 |
| 8.8 | Wiring diagram with booster connection (MOD 26) | 17 | | | |
| 8.9 | Wiring diagram with "Temp- erature reached" signal (MOD 40) or „Temp. OK“ signal (MOD 46) | 18 | | | |

1 Safety and warning notes

This RESISTRON temperature controller is manufactured according to DIN EN 61010-1. In the course of its manufacture it passed through quality assurance, whereby it was subjected to extensive inspections and tests.

It left the factory in perfect condition.

The recommendations and warning notes contained in these operating instructions must be complied with, in order to guarantee safe operation.

The device can be operated within the limits indicated in the "Technical Data" without impairing its operational safety. Installation and maintenance may only be performed by technically trained, skilled persons who are familiar with the associated risks and warranty provisions.

1.1 Use

RESISTRON temperature controllers may only be used for heating and temperature control of heatsealing bands which are expressly suitable for them, and providing the regulations, notes and warnings contained in these instructions are complied with.

 **In case of non-compliance or use contrary to the intended purpose, there is a risk that safety will be impaired or that the heatsealing band, electrical wiring, transformer etc. will overheat. Ensuring such compliance is the personal responsibility of the user.**

1.2 Heatsealing band

A basic prerequisite for reliable and safe operation of the system is the use of suitable heatsealing bands.

 **The resistance of the heatsealing band which is used must have a positive minimum temperature coefficient in order to guarantee trouble-free operation of the RESISTRON temperature controller.**

The temperature coefficient must be specified as follows:

$$TCR \geq 10 \times 10^{-4} \text{ K}^{-1}$$

e.g. Alloy-20: TCR = 1100 ppm/K
NOREX: TCR = 3500 ppm/K

The RESISTRON temperature controller must be set and coded according to the temperature coefficient of the heatsealing band.

 **The use of incorrect alloys with a too low temperature coefficient and incorrect coding of the RESISTRON temperature controller lead to uncontrolled heating and ultimately to burn-out of the heatsealing band!**

The heatsealing bands that were originally supplied must be identified by detail specification, part number or some other means that will assure that replacement bands are identical.

1.3 Impulse transformer

A suitable impulse transformer is necessary to ensure that the control loop functions perfectly. This transformer must be designed according to VDE 0570/EN 61558 (isolating transformer with reinforced insulation) and have a one section bobbin. When the impulse transformer is installed, suitable shock protection must be provided in accordance with the national installation regulations for electrical equipment. In addition, water, cleaning solutions and conductive fluids must be prevented from seeping into the transformer.

 **Incorrect installation of the impulse transformer impairs electrical safety.**

1.4 Current transformer PEX-W2/-W3

The current transformer supplied with the RESISTRON temperature controller is an integral part of the control system.

 **Only the original ROPEX PEX-W2 or PEX-W3 current transformer may be used. Other transformers may cause the equipment to malfunction.**

The current transformer may only be operated if it is connected to the RESISTRON temperature controller correctly (see section 9, "Startup and operation"). The relevant safety instructions contained in section 8.3, "Power supply", must be obeyed. External monitoring modules can be used in order to additionally increase

operating safety. They are not included in the scope of supply of the standard control system and are described in a separate document.

1.5 Line filter

The use of an original ROPEX line filter is mandatory in order to comply with the standards and provisions mentioned in section 1.7 "Standards / CE marking" on page 4. This device must be installed and connected according to the instructions contained in section 8.3, "Power supply" as well as the separate documentation enclosed with the line filter.

1.6 Warranty provisions

The statutory provisions for warranties apply for a period of 12 months following the delivery date.

All devices are tested and calibrated in the factory. Devices that have been damaged due to faulty connections, dropping, electrical overloading, natural wear, incorrect or negligent handling, chemical influences or mechanical overloading as well as devices that have been modified, relabeled or otherwise altered by the customer, for example in an attempt to repair them or install additional components, are excluded from the warranty.

Warranty claims must be examined in the factory and approved by ROPEX.

1.7 Standards / CE marking

The controller described here complies with the following standards, provisions and directives:

| | |
|--------------------------------|---|
| DIN EN 61010-1 (VDE 0411-1) | Safety provisions for electrical measuring, control and laboratory devices (low voltage directive). Overvoltage category III, pollution severity 2, safety class II. |
| DIN EN 60204-1 | Electrical equipment of machines (machinery directive) |
| EN 50081-1 | EMC interference emissions according to EN 55011, group 1, class B |
| EN 50082-2 | EMC interference immunity: ESDs, RF radiation, bursts, surges. |

Compliance with these standards and provisions is only guaranteed if original accessories and/or peripheral components approved by ROPEX are used. If not, then the equipment is operated on the user's own responsibility.

The CE marking on the controller confirms that the device itself complies with the above-mentioned standards.

It does not imply, however, that the overall system also fulfils these standards.

It is the responsibility of the machine manufacturer and of the user to verify the completely installed, wired and operationally ready system in the machine with regard to its conformity with the safety provisions and the EMC directive (see also section 8.3, "Power supply"). If peripheral components (e.g. the transformer or the line filter) from other manufacturers are used, no functional guarantee can be provided by ROPEX.

2 Application

This RESISTRON temperature controller is an integral part of the "series 400", the outstanding feature of which is its microprocessor technology. All RESISTRON temperature controllers are used to control the temperature of heating elements (heatsealing bands, beaded bands, cutting wires, heatsealing blades, solder elements etc.), as required in a variety of heatsealing processes.

The controller is most commonly used for impulse-heatsealing PE and PP films in:

- Vertical and horizontal f/f/s machines
- Pouch, filling and sealing machines
- Film wrapping machines
- Pouch-making machines
- Group packaging machines
- L-sealers

- etc.

The use of RESISTRON temperature controllers results in:

- Repeatability of the heatseals under any conditions
- Increased machine capacity
- Extended life of the heatsealing bands and teflon coatings
- Simple operation and control of the sealing process

3 Principle of operation

The resistance of the heatsealing band, which is temperature-sensitive, is monitored 50x per second (60x at 60Hz) by measuring the current and voltage. The temperature calculated with the help of these measurements is displayed and compared with the set point.

The primary voltage of the impulse transformer is adjusted by phase-angle control if the measured values deviate from the set point. The resulting change in the current through the heatsealing band leads to a change in the band temperature and thus also its resistance. This change is measured and evaluated by the RESISTRON temperature controller.

The control loop is closed: ACTUAL temperature = SET temperature. Even minute thermal loads on the heatsealing band are detected and can be corrected quickly and precisely.

The thermoelectric control loop which is formed has a highly dynamic response because purely electrical variables are measured at a high sampling rate. A very wide secondary current range can be controlled with only minimal power loss - a considerable advantage - because power is controlled on the primary side of the

transformer. This allows optimum adaptation to the load and to the required dynamic range despite the exceptionally compact dimensions of the controller.

PLEASE NOTE!

RESISTRON temperature controller play a significant role in enhancing the performance of modern machines. However, the full benefit can only be obtained from the advanced technology offered by this control system if all the system components, in other words the heatsealing band, the impulse transformer, the wiring, the timing signals and the controller itself, are compatible with one another.

We will be pleased to contribute our many years of experience towards optimizing your heatsealing system.

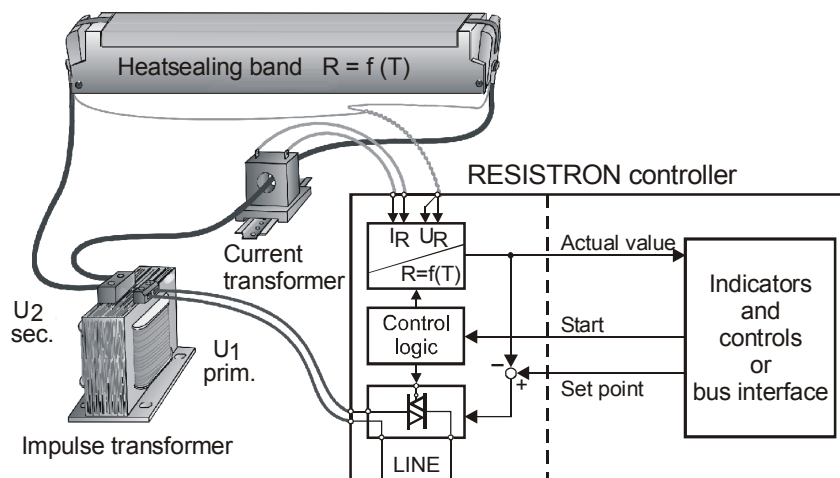

4 Description of the controller

The microprocessor technology endows the RESISTRON temperature controller RES-407 with previously unattainable capabilities:

- Very simple operation thanks to AUTOCAL, the automatic zero calibration function.
- Good dynamic response of the control system thanks to AUTOTUNE, which adapts automatically to the controlled system.
- High precision thanks to further improved control accuracy and linearization of the heatsealing band characteristic.
- High flexibility: The AUTORANGE function (as of April 2005) covers a secondary voltage range from 0.4V to 120V and a current range from 30A to 500A.
- Automatic adjustment to the line frequency in the range from 47Hz to 63Hz.
- Increased protection against dangerous conditions, such as overheating of the heatsealing band.

The electrically isolated analog interfaces for the temperature set point and the actual temperature (0-10VDC) allow the temperature to be set either

directly on the machine PLC or by means of an external potentiometer (PD-x).

Similarly, the real heatsealing band temperature can be visualized either on the display of the machine PLC or on an external temperature meter (ATR-x).

The RESISTRON temperature controller RES-407 features an integrated fault diagnosis function, which tests both the external system (heatsealing band, wiring etc.) and the internal electronics and outputs a selective error message in case of a fault.

To increase operational safety and interference immunity, all 24VDC logic signals are electrically isolated from the controller and the heating circuit.

Coding switches on the temperature controller itself can be used to adapt to different heatsealing band alloys (Alloy A20, NOREX etc.) and set the required temperature range (0...300°C, 0...500°C etc.) on all controllers manufactured as of June 2003.

An external 24VDC auxiliary voltage is required to supply the isolating amplifiers and optocouplers. The compact design of the RESISTRON temperature controller RES-407 and the plug-in connections make this controller easy to install.

5 Accessories and modifications

A wide range of compatible accessories and peripheral devices are available for the RESISTRON temperature controller RES-407. They allow it to be optimally adapted to your specific heatsealing application and to your plant's design and operating philosophy.

5.1 Accessories

The products described below are only a few of the wide range of accessories available for RESISTRON temperature controllers (↳ "Accessories" leaflet).



Analog temperature meter ATR-x

For front panel mounting or mounting on a top hat rail (DIN TS35 rail).

Analog indication of the ACTUAL temperature of the heatsealing band in °C. The meter damping of the unit is optimized for the abrupt temperature changes that occur in impulse mode.



Digital temperature meter DTR-x

For front panel mounting or mounting on a top hat rail (DIN TS35 rail).

Digital indication of the ACTUAL temperature of the heatsealing band in °C, with HOLD function.

| | |
|---|---|
|  | <p>Set point potentiometer PD-x Front panel-mounting version for setting the required SET heatsealing temperature of the RESISTRON temperature controller. The number which appears on the display corresponds to the SET heatsealing temperature in °C.</p> |
|  | <p>Line filter Essential in order to ensure CE conformity. Optimized for the RESISTRON temperature controller.</p> |
|  | <p>Impulse transformer Designed according to VDE 0570/EN 61558 with a one-section bobbin. Optimized for impulse operation with RESISTRON temperature controllers. Specified according to the heatsealing application (↪ ROPEX Application Report).</p> |
|  | <p>Communication interface CI-USB-1 Interface for connecting a RESISTRON temperature controller with diagnostic interface (DIAG) to the PC (USB port). Associated PC visualization software for displaying setting and configuration data, and for recording SET and ACTUAL temperatures in real time.</p> |
|  | <p>Booster External switching amplifier, necessary for high primary currents (continuous current > 5A, pulsed current > 25A).</p> |
|  | <p>Monitoring current transformer For detecting frame short-circuits on the heatsealing band. Used as an alternative to the standard PEX-W2/-W3 current transformer.</p> |

5.2 Modifications (MODs)

Owing to its universal design, the RESISTRON temperature controller RES-407 is suitable for a very wide range of heatsealing applications. Various modifications (MODs) are offered for the RESISTRON temperature controller RES-407 for implementing special applications.

The modifications described here are just a few of the large number available. Separate documents are supplied for all modifications.

MOD 01

Amplifier for low secondary voltages ($U_R = 0.25...16VAC$). This modification is necessary, for example, for very short or low-resistance heatsealing bands.

MOD 21

Inverts the alarm signal (terminal 18). If an alarm is signaled, the alarm output is switched to open condition (LOW). If the controller does not report an alarm, a 24VDC voltage level (HIGH) is output at terminal 18.

MOD 26

Additional terminal for connecting an external switching amplifier (booster). This modification is necessary for high primary currents (continuous current > 5A, pulsed current > 25A).

MOD 37 (until May 2003)

Additional rotary coding switch for the heatsealing band alloy and the temperature range. Various heatsealing band alloys (e.g. Alloy-20, NOREX) and temperature ranges (e.g. 300°C, 500°C) can be selected.

! This modification is supplied as standard with all controllers manufactured as of June 2003 (see section 9.2.2 "Configuration of the rotary coding switch for the temperature range and alloy (as of June 2003)" on page 20).

| Switch position | Temp. range | Temp. coefficient | Band alloy |
|-----------------|-------------|-------------------|---------------|
| 0 | 300°C | 1100ppm/K | e.g. Alloy-20 |
| 1 | 300°C | 780ppm/K | e.g. Alloy L |
| 4 | 500°C | 1100ppm/K | e.g. Alloy-20 |
| 5 | 500°C | 780ppm/K | e.g. Alloy L |
| 8 | 300°C | 3500ppm/K | e.g. NOREX |

0 = Factory settings

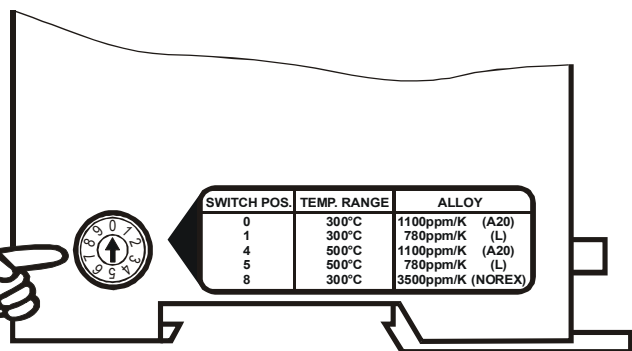

MOD 40

Additional terminal for "Temperature reached" signal. This output signal is activated when the ACTUAL temperature of the heatsealing band exceeds 95% of the SET heatsealing temperature. It can be used to

monitor the process, for example, or to control the closure of the heatsealing bars.

! MOD 40 cannot be used in combination with MOD 26 (booster connection) manufactured prior to March 2005.

MOD 46 (as of April 2005)

Additional terminal for "Temperature OK" signal. If this modification is installed, the RES-407 checks whether the ACTUAL temperature is within a settable tolerance band ("OK" window) on either side of the SET temperature. The lower ($\Delta\vartheta_{lower}$) and upper ($\Delta\vartheta_{upper}$) tolerance band limits are configured in the factory to -10K and +10K. These values can be set independently of one another in the ROPEX visualization software (see section 10.11 "Diagnostic interface/visualization software (as of April 2005)" on page 31).

If the actual temperature is inside the specified tolerance band when the "START" signal is activated, the output signal is activated as well (see graph below):

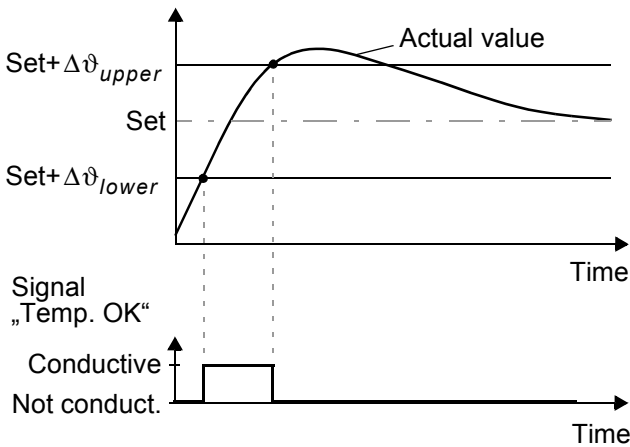

If the actual temperature leaves the tolerance band, the output signal is deactivated again. The output signal then remains deactivated, even if the actual temperature subsequently returns to the tolerance band.



It is thus possible to check - as part of the monitoring concept, for instance - whether the output signal is still active at the end of the heatsealing process, in other words whether the actual temperature has remained within the defined tolerance band throughout the entire process.

The output signal is not deactivated again until the next "START" signal is activated or until an alarm is signaled.

! MOD 46 ("Temperature OK" signal) cannot be used in combination with MOD 40 ("Temperature reached" signal).

6 Technical data

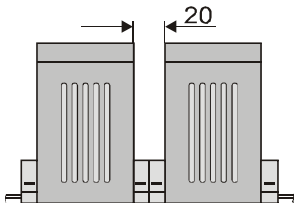
| | |
|---|--|
| Type of construction | Housing for installation in the electrical cabinet Snaps onto a standard top hat rail (DIN TS35 rail, 35mm) acc. to DIN EN 50022 Dimensions: 90 x 75mm; height: 135mm (incl. terminals) |
| Line voltage | <p><u>All controllers manufactured as of April 2005:</u> 115VAC version: 110VAC -15%...120VAC +10% (equivalent to 94...132VAC) 230VAC version: 220VAC -15%...240VAC +10% (equivalent to 187...264VAC) 400VAC version: 380VAC -15%...415VAC +10% (equivalent to 323...456VAC)</p> <p><u>All controllers manufactured as of January 2004 up to March 2005:</u> 115VAC version: 115VAC -15%...120VAC +10% (equivalent to 98...132VAC) 230VAC version: 230VAC -15%...240VAC +10% (equivalent to 196...264VAC) 400VAC version: 400VAC -15%...415VAC +10% (equivalent to 340...456VAC)</p> <p><u>All controllers manufactured up to December 2003:</u> 115VAC, 230VAC or 400VAC, tolerance: +10% / -15%</p> <p>Depending on the controller version (↪ section 13 "How to order" on page 40)</p> |
| Line frequency | 47...63Hz, automatic adjustment to frequencies in this range |
| Auxiliary voltage Terminals 12+13 | 24VDC, +20%, -10%, reverse polarity-protected Current input (up to March 2005): max. 50mA (as of April 2005): max. 1.0A |
| Heatsealing band type and temperature range | <p><u>All controllers manufactured as of April 2005:</u> The temperature range and temperature coefficient settings can also be specified by means of the ROPEX visualization software (↪ section 10.11 "Diagnostic interface/visualization software (as of April 2005)" on page 31) in addition to the rotary coding switch (see below): Temperature range: 200°C, 300°C, 400°C or 500°C Temperature coefficient: 400...4000ppm (variable setting range)</p> <p><u>All controllers manufactured as of June 2003:</u> Five different ranges can be set on the controller with a rotary coding switch: Temperature coefficient 1100ppm, 0...300°C (e.g. Alloy A20), default Temperature coefficient 780ppm, 0...300°C (e.g. Alloy L) Temperature coefficient 1100ppm, 0...500°C (e.g. Alloy A20) Temperature coefficient 780ppm, 0...500°C (e.g. Alloy L) Temperature coefficient 3500ppm, 0...300°C (e.g. NOREX)</p> <p><u>All controllers manufactured up to May 2003:</u> Default value 300°C, Alloy-20 The temperature range and alloy are selectable with MOD 37.</p> |
| Analog input (set point) Terminals 16+14 | 0...10VDC, $I_{max} = 5\text{mA}$, electrically isolated Equivalent to 0...300°C or 0...500°C or with an external PD-3 or PD-5 precision potentiometer ($R = 2\text{kohms}$) 0...2kohms equivalent to 0...300°C or 0...500°C |
| Analog output (actual value) Terminals 17+14 | 0...10VDC, $I_{max} = 5\text{mA}$, electrically isolated Equivalent to 0...300°C or 0...500°C Accuracy: $\pm 1\%$ add. 50mV |

| | |
|---|---|
| Reference voltage | +10VDC / $\pm 5\%$, $I_{max} = 5\text{mA}$ |
| Digital logic levels Terminals 5, 6, 7 | LOW (0V): 0...2VDC, electrically isolated HIGH (24VDC): 12...30VDC (max. current input 6mA) Reverse polarity-protected |
| Switching output for "Temp. OK" signal (MOD 40) | $U_{max} = 30\text{VDC}$ $I_{max} = 50\text{mA}$ $U_{ON} < 2\text{V}$ (saturation voltage) |
| Alarm output | $U_{ON} < 3\text{V}$ (saturation voltage), electrically isolated, short-circuit proof Up to March 2005: $I_{max} = 40\text{mA}$ As of April 2005: $I_{max} = 200\text{mA}$ As of April 2005, the output can also be inverted by means of a plug-in jumper. |
| Maximum load (primary current of impulse transformer) | $I_{max} = 5\text{A}$ (duty cycle = 100%) $I_{max} = 25\text{A}$ (duty cycle = 20%) |
| Power dissipation | max. 20W |
| Ambient temperature | +5...+45°C |
| Degree of protection | IP20 |
| Installation | <p>If several controllers are installed on one top hat rail (DIN TS35 rail), a clearance of at least 20mm should be allowed between them.</p>  <p>The moving clip required for fastening must be facing down for mounting on a horizontal top hat rail.</p> <p>End holders to mechanical fix the controller must be fitted at both ends for mounting on a vertical top hat rail.</p> |
| Weight | Approx. 0.7 kg (incl. connector plug-in parts) |
| Housing material | Plastic, polycarbonate, UL-90-V0 |
| Connecting cables Type / cross-sections | Rigid or flexible; 0.2...2.5mm ² (AWG 24...12) Plug-in connectors |
| | <p> If ferrules are used, they must be crimped in accordance with DIN 46228 and IEC/EN 60947-1. This is essential for proper electrical contact in the terminals.</p> |

7 Dimensions

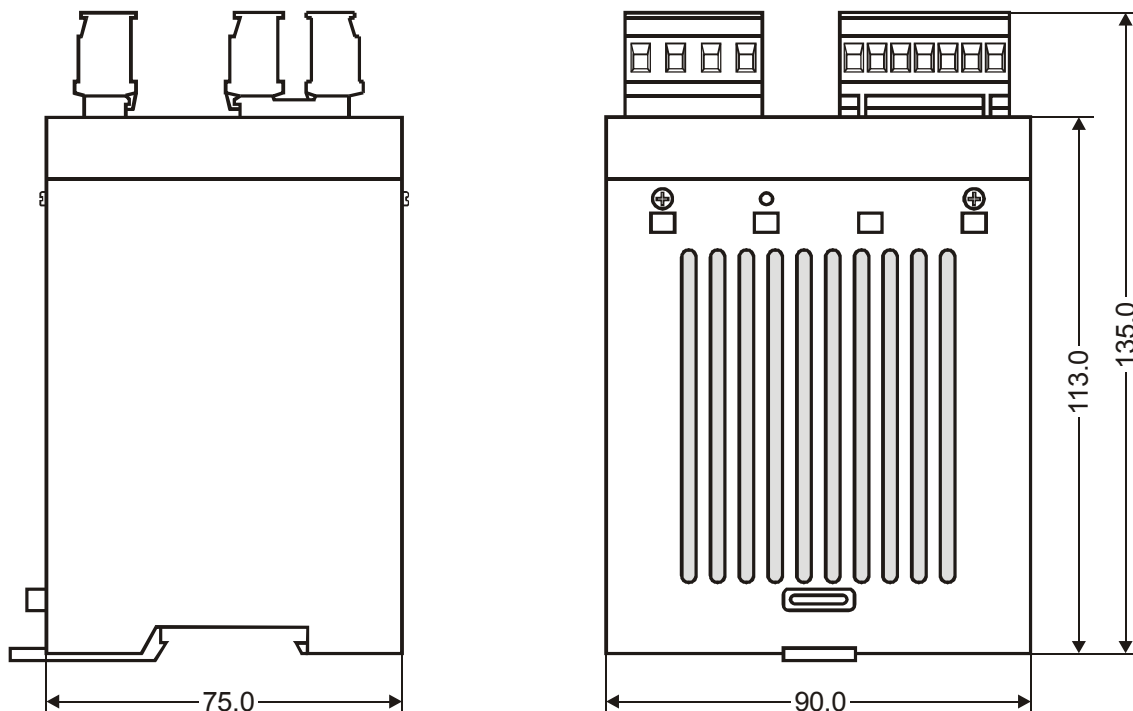

8 Installation

↳ See also section 1 "Safety and warning notes" on page 3.

⚠ Installation and startup may only be performed by technically trained, skilled persons who are familiar with the associated risks and warranty provisions.

8.1 Installation procedure

Proceed as follows to install the RESISTRON temperature controller RES-407:

1. Switch off the line voltage and verify that all circuits are deenergized.
2. The supply voltage specified on the nameplate of the RESISTRON temperature controller must be identical to the line voltage that is present in the plant or machine. The line frequency is

automatically detected by the temperature controller in the range from 47Hz to 63Hz.

3. Install the RESISTRON temperature controller in the electrical cabinet on a standard top hat rail (DIN TS35 rail, according to DIN EN 50022). If several controllers are installed on one top hat rail, the minimum clearance specified in section 6 "Technical data" on page 10 must be allowed between them.
4. Wire the system in accordance with the instructions in section 8.3 "Power supply" on page 14, section 8.6 "Auxiliary voltage" on page 16 and the ROPEX Application Report. The information provided in section 8.2 "Installation steps" on page 13 must be heeded additionally.

⚠ Check the tightness of all the system connections, including the terminals for the impulse transformer windings.

5. Make sure that the wiring conforms to the relevant national and international installation regulations.

8.2 Installation steps

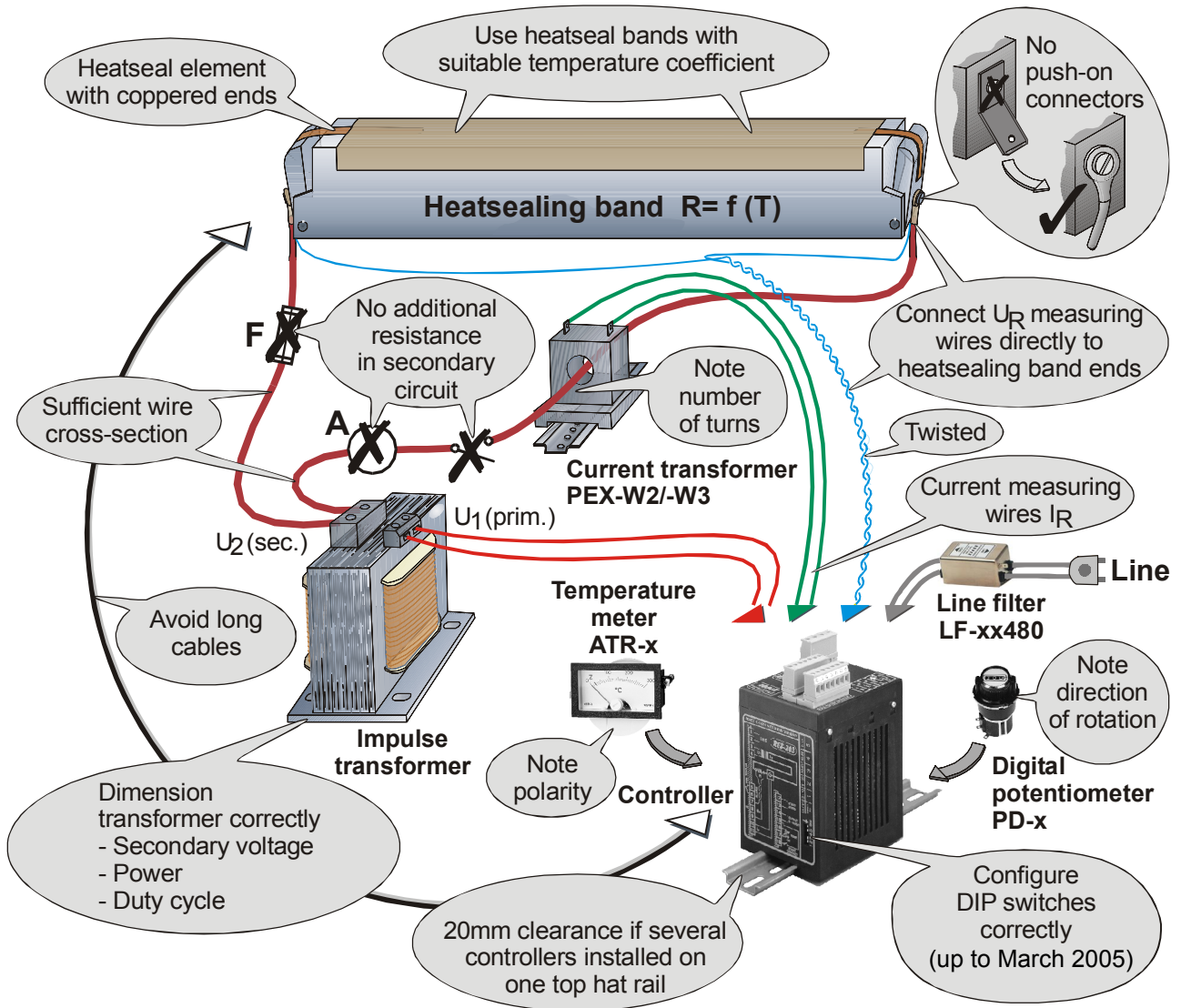

8.3 Power supply

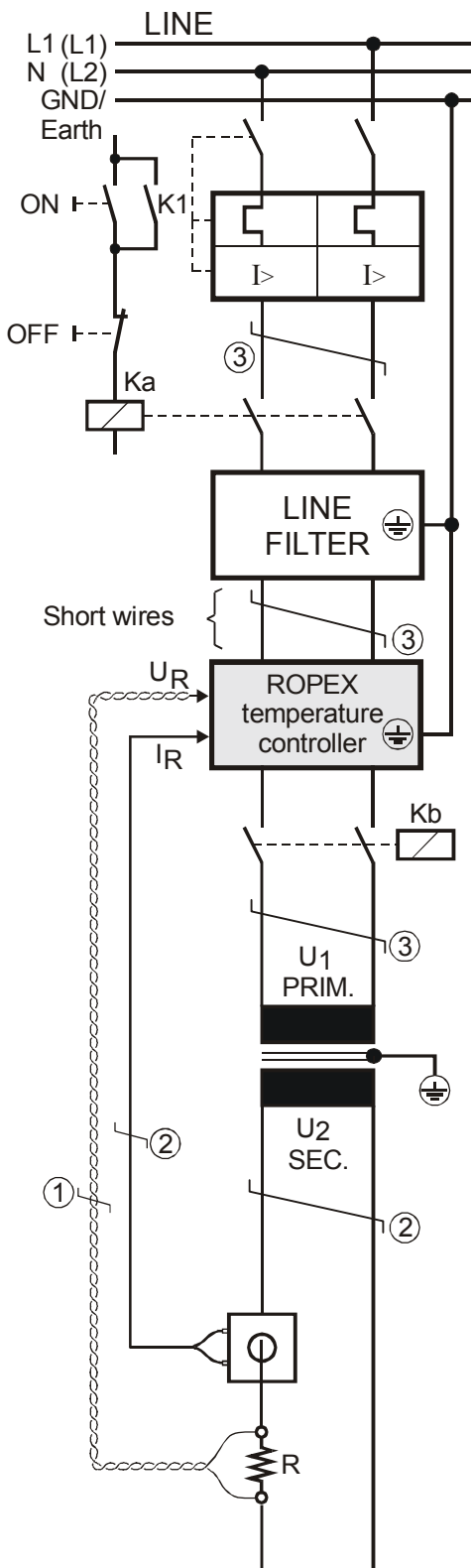

Line

115VAC, 230VAC, 400VAC
50/60Hz

Circuit breaker

Double-pole, C characteristic
(☞ ROPEX Application Report)

⚠ Short-circuit protection only.
RESISTRON temperature controller not protected.

Relay Ka

For "HEAT ON - OFF" function (all-pole) or "EMERGENCY STOP".

Line filter

The filter type and size must be determined according to the load, the transformer and the machine wiring (☞ ROPEX Application Report).

⚠ Do not run the filter supply wires (line side) parallel to the filter output wires (load side).

RESISTRON temperature controller belonging to the 4xx Series.

Relay Kb

Load break (all-pole), e.g. in combination with the alarm output of the temperature controller.

⚠ When using a series resistor RV-....-1 the relay Kb shall be installed.

Impulse Transformer

Designed according to VDE 0570/EN 61558 (isolating transformer with reinforced insulation). Connect core to ground.

⚠ Use transformers with a one section bobbin. The power, duty cycle and voltage values must be determined individually according to the application (☞ ROPEX Application Report and "Accessories" leaflet for impulse transformers).

Wiring

The wire cross-sections depend on the application (☞ ROPEX Application Report).

Guide values:

Primary circuit: min. 1.5mm², max. 2.5mm²

Secondary circuit: min. 4.0mm², max. 25mm²

- ① These wires must always be twisted (>20/m)
- ② These wires must be twisted (>20/m) if several control loops are laid together ("crosstalk").
- ③ Twisting (>20/m) is recommended to improve EMC.

8.4 Line filter

To comply with EMC directives – corresponding to EN 50081-1 and EN 50082-2 – RESISTRON control loops must be operated with line filters. These filters damp the reaction of the phase-angle control on the line and protect the controller against line disturbances.

⚠ The use of a suitable line filter is part of the standards conformity and a prerequisite of the CE mark.

installed and wired correctly, they guarantee compliance with the EMC limit values. You can find the exact specification of the line filter in the ROPEX Application Report calculated for your particular heatsealing application. For more technical information: ↪ "Line filter" documentation.

⚠ It is permissible to supply several RESISTRON control loops with a single line filter, providing the total current does not exceed the maximum current of the filter.

ROPEX line filters are specially optimized for use in RESISTRON control loops. Providing that they are

The wiring instructions contained in section 8.3 "Power supply" on page 14 must be observed.

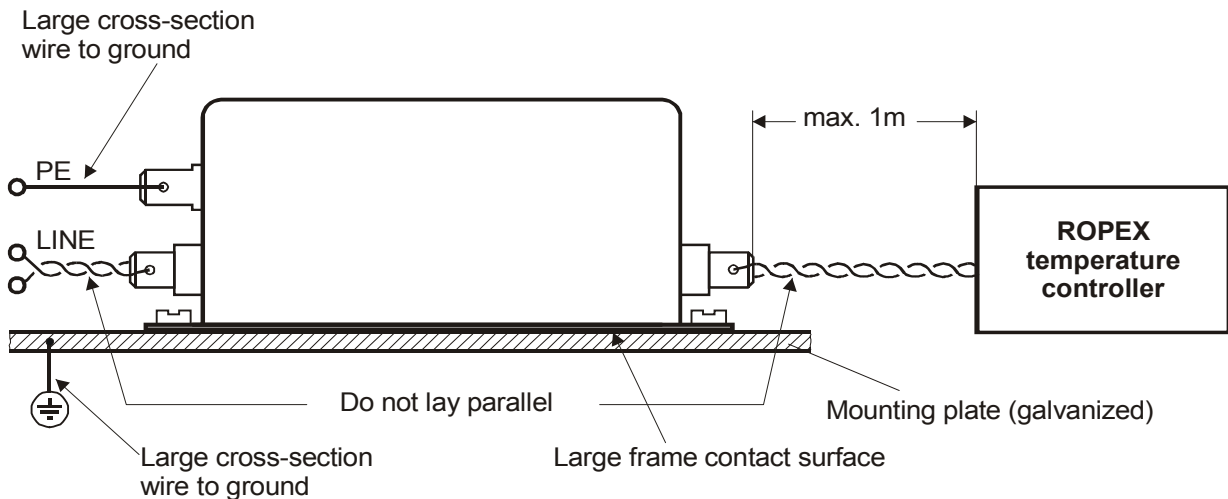

8.5 Current transformer PEX-W3

The PEX-W3 current transformer supplied with the RESISTRON temperature controller is an integral part

of the control system. The current transformer may only be operated if it is connected to the temperature controller correctly (↪ section 8.3 "Power supply" on page 14).

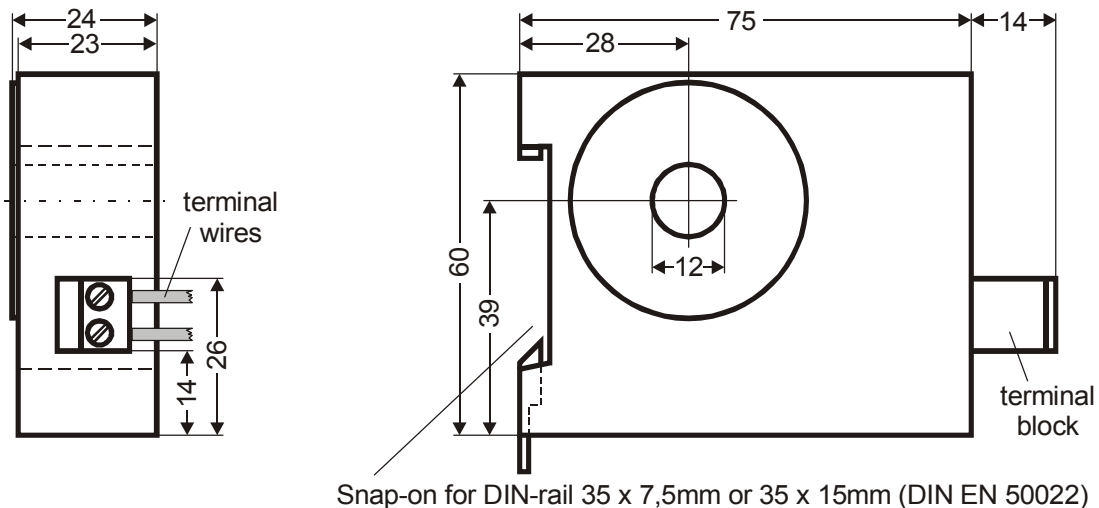

8.6 Auxiliary voltage

Since the inputs and outputs of the RES-407 are electrically isolated, a 24VDC auxiliary voltage must be applied to terminals 12+13. The auxiliary voltage has a

maximum current input of 1,0A and it is also protected against reverse polarity.

8.7 Wiring diagram (standard)

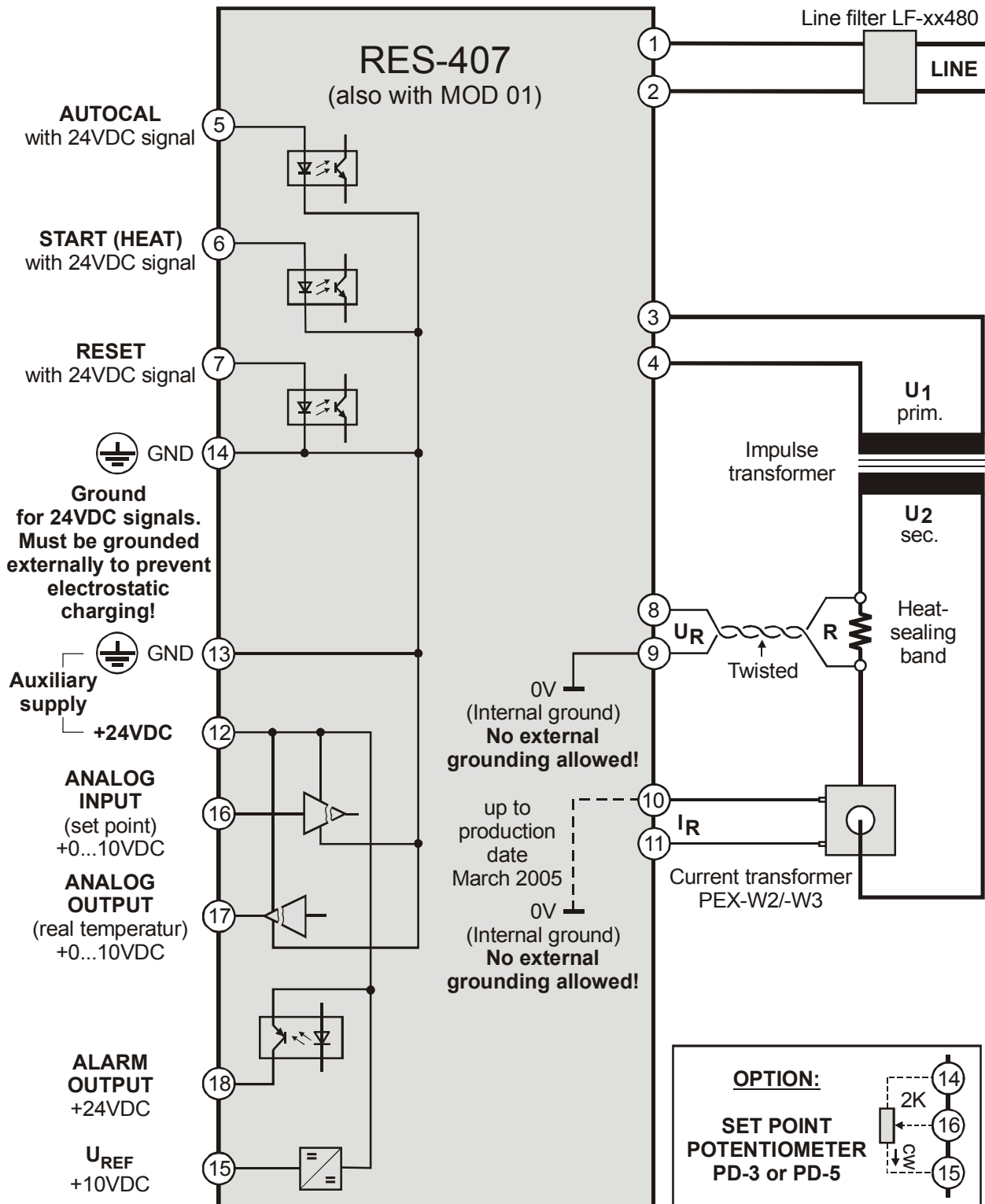

8.8 Wiring diagram with booster connection (MOD 26)

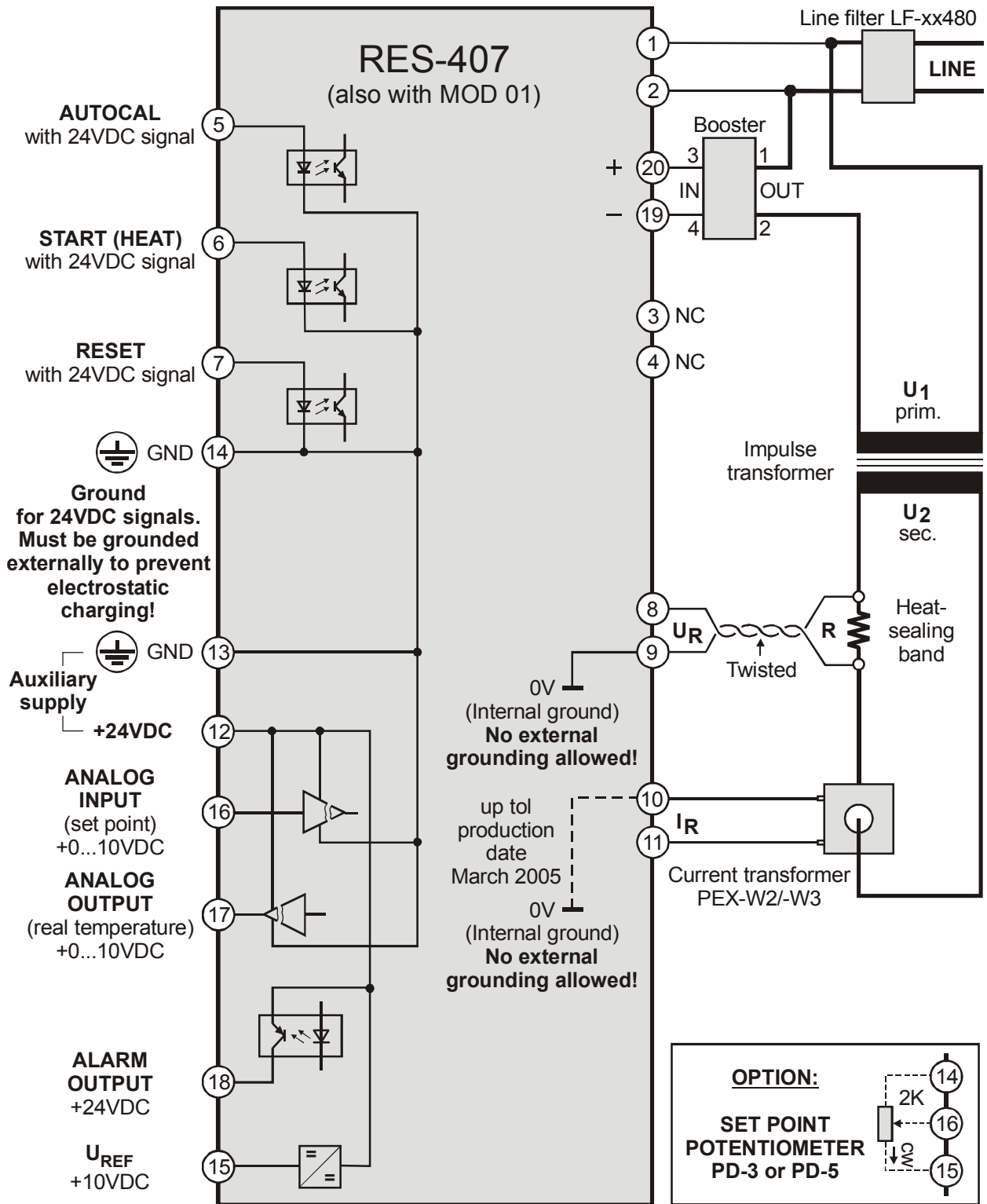

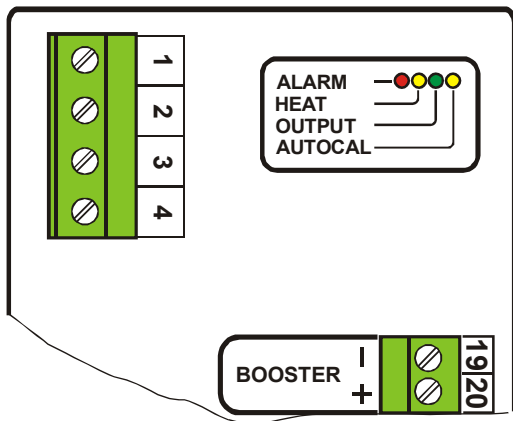

Additional terminals in housing cover for MOD 26 (booster connection)

! MOD 26 cannot be used in combination with MOD 40 ("Temperature OK" signal) manufactured up to March 2005.

8.9 Wiring diagram with "Temperature reached" signal (MOD 40) or „Temp. OK“ signal (MOD 46)

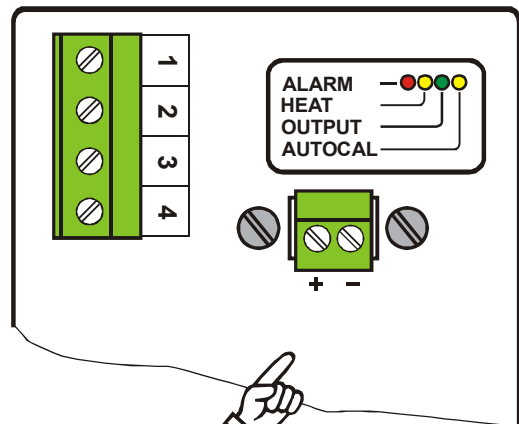
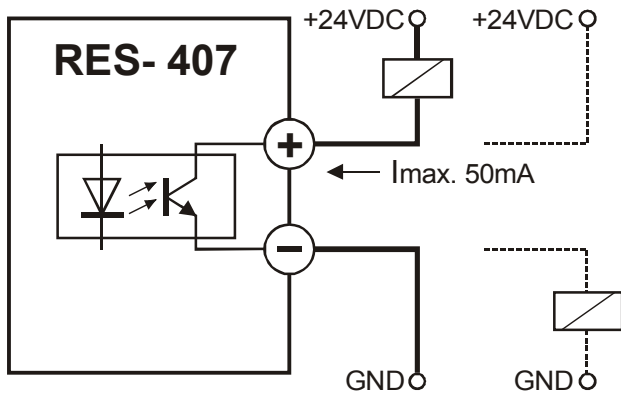

Additional terminals in housing cover for MOD 40 ("Temp. reached" signal) or MOD 46 ("Temp. OK" signal)

! MOD 40 cannot be used in combination with MOD 26 (booster connection) manufactured prior to March 2005.

! MOD 46 cannot be used in combination with MOD 40.

9 Startup and operation

9.1 View of the controller

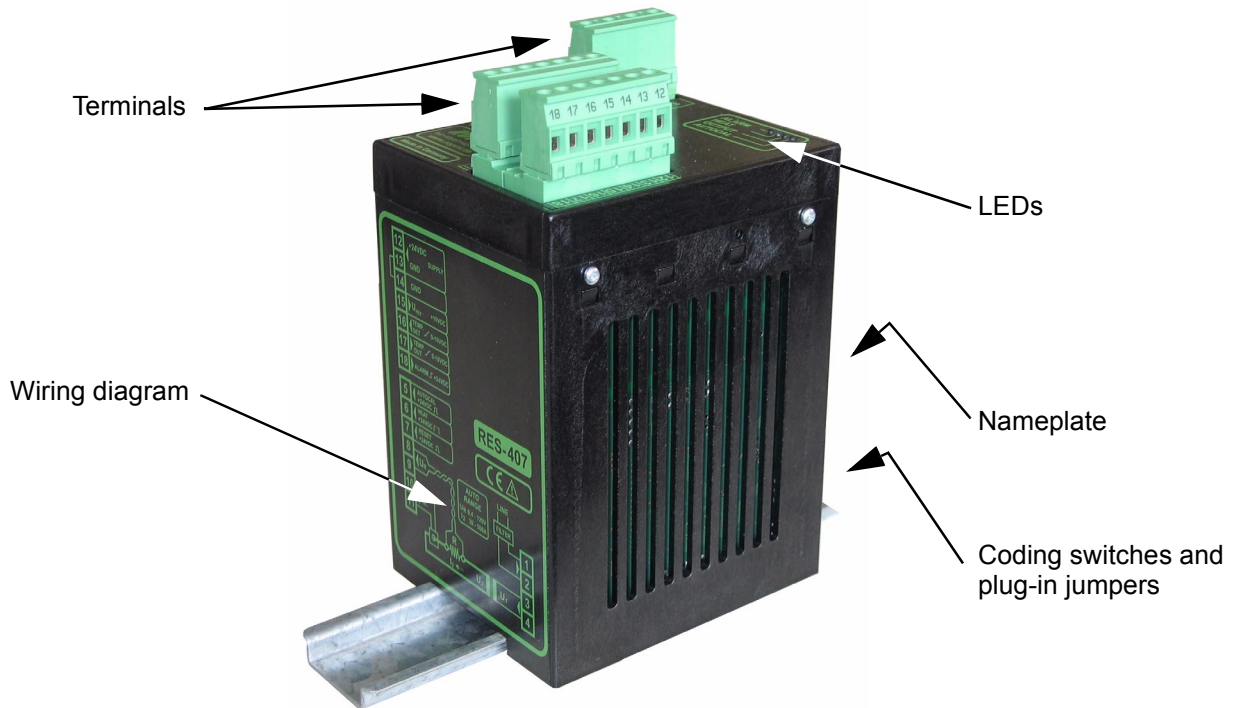

9.2 Controller configuration

! The controller must be switched off in order to configure the coding switches and the plug-in jumpers.

9.2.1 Configuration of the DIP switches for secondary voltage and current

Automatic configuration (AUTORANGE) (as of April 2005)

The secondary voltage and current ranges are automatically configured by the automatic calibration function (AUTOCAL). The voltage is configured in the range from 0.4VAC to 120VAC and the current in the range from 30A to 500A. If the voltage and/or the

current is outside the permissible range, a detailed error message appears on the controller (see section 10.13 "Error messages" on page 32).

Configuration with coding switches (up to March 2005)

Set the DIP switches for matching the secondary voltage U_2 and the secondary current I_2 to the correct position for your application.

! You can find the exact configuration of the DIP switches in the ROPEX Application Report calculated for your particular application.

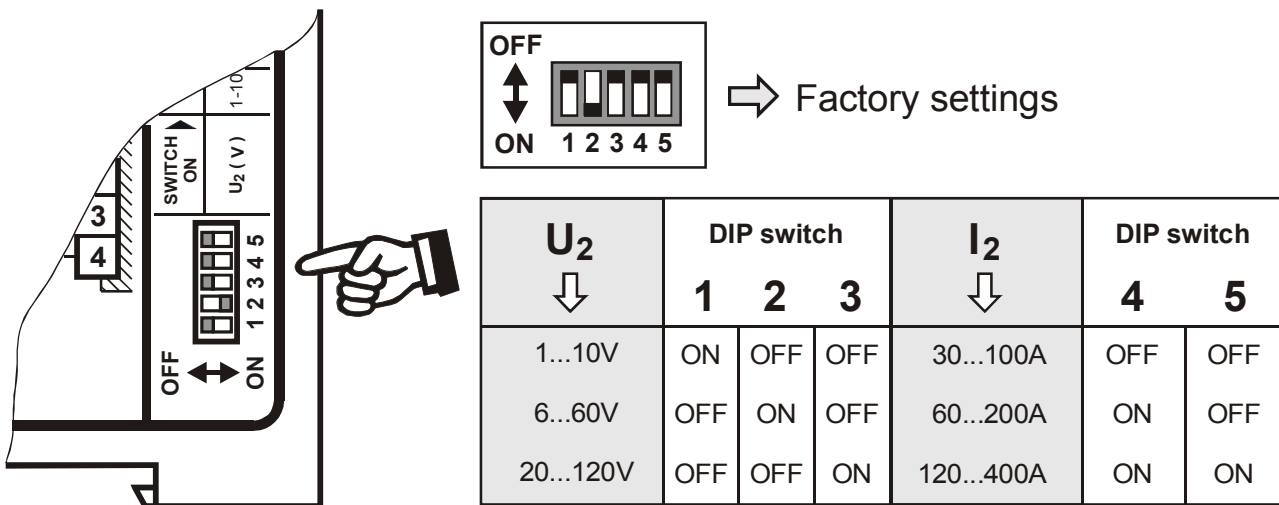

If the secondary current I_2 is less than 30 A, the PEX-W2 or PEX-W3 current transformer must have two turns (↪ ROPEX Application Report).



9.2.2 Configuration of the rotary coding switch for the temperature range and alloy (as of June 2003)

| Switch position | Temp. range | Temp. coefficient | Band alloy |
|-----------------|------------------|-------------------|---------------|
| 0 | 300°C | 1100ppm/K | e.g. Alloy-20 |
| 1 | 300°C | 780ppm/K | e.g. Alloy L |
| 4 | 500°C | 1100ppm/K | e.g. Alloy-20 |
| 5 | 500°C | 780ppm/K | e.g. Alloy L |
| 8 | 300°C | 3500ppm/K | e.g. NOREX |
| 9 | PC-CONFIGURATION | | |



! This configuration is supplied as standard with all controllers manufactured as of June 2003. The settings are only possible on older controllers in conjunction with MOD 37 (↪ section "MOD 37 (until May 2003)" on page 8).

If the switch is set to "9" (as of April 2005), more temperature ranges and alloys can be selected by means of the ROPEX visualization software (↪ see section 10.11 "Diagnostic interface/visualization software (as of April 2005)" on page 31).

9.2.3 Configuration of the alarm output (as of April 2005)

Alarm output opened
(HIGH) by alarm/
PC-CONFIGURATION.

Alarm output closed
(LOW) by alarm.
(factory setting)

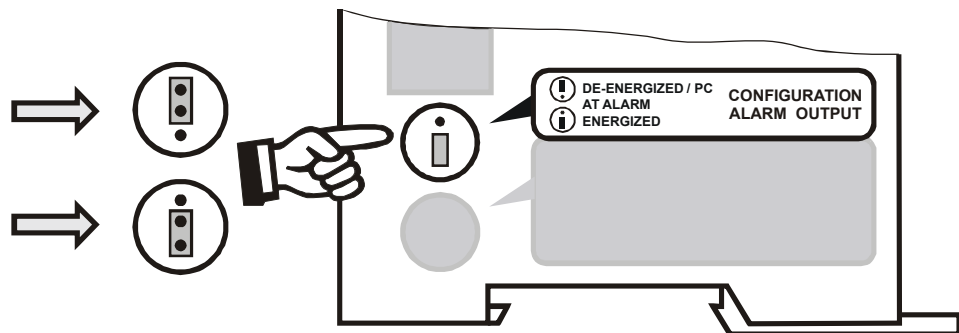

! If the plug-jumper is not inserted - or if it is incorrectly inserted - an error message appears when the controller is switched on (↪ section 10.13 "Error messages" on page 32).

If the "Alarm output opened by alarm/PC CONFIGURATION" position is selected (as of April 2005), the behavior of the alarm output can be configured in more detail by means of the ROPEX visualization software (↪ see section 10.11 "Diagnostic interface/visualization software (as of April 2005)" on page 31).

9.3 Heatsealing band

9.3.1 General

The heatsealing band is a key component in the control loop, since it is both a heating element and a sensor. The geometry of the heatsealing band is too complex to be discussed at length here. We shall therefore only refer to a few of the most important physical and electrical properties:

The measuring principle applied for this system necessitates a heatsealing band alloy with a suitable temperature coefficient TCR, i.e. one whose resistance increases as the temperature rises.

Too low a TCR leads to oscillation or uncontrolled heating.

When heatsealing bands with a higher TCR are used, the controller must be calibrated for this.

The first time the heatsealing band is heated to approximately 200...250°C, the standard alloy undergoes a once-only resistance change (burn-in effect). The cold resistance of the heatsealing band is reduced by approximately 2...3%. However, this at first glance slight resistance change results in a zero point error of 20...30°C. The zero point must therefore be

corrected after a few heating cycles (↪ section 9.3.2 "Burning in the heatsealing band" on page 21).

One very important design feature is the copper or silver-plating of the heatsealing band ends. Cold ends allow the temperature to be controlled accurately and increase the life of the teflon coating and the heatsealing band.

! An overheated or burned-out heatsealing band must no longer be used because the TCR has been altered irreversibly.

9.3.2 Burning in the heatsealing band

If a new heatsealing band has been used, the zero point is first of all calibrated while the band is still cold by activating the "AUTOCAL" function on the controller. When the "AUTOCAL" function has finished, the controller outputs a voltage equivalent to a temperature of 20°C at the actual value output. Adjust the set point to approximately 250°C and activate the "START" signal to heat for approximately 1 second. After recooling, the controller usually outputs an actual value of less than 20°C. Repeat the "AUTOCAL" function. The heatsealing band has now been burned in and the change in the alloy stabilized.

The burn-in effect described here does not occur if the heatsealing band has already been thermally pretreated by the manufacturer.

9.3.3 Replacing the heatsealing band

All power supply leads must be disconnected from the RESISTRON temperature controller in order to replace the heatsealing band.

! The heatsealing band must be replaced in accordance with the instructions provided by the manufacturer.

Each time the heatsealing band is replaced, the zero point must be calibrated with the AUTOCAL function while the band is still cold, in order to compensate production-related resistance tolerances. The burn-in procedure described above should be performed for all new heatsealing bands.

9.4 Startup procedure

Please also refer to section 1 "Safety and warning notes" on page 3 and section 2 "Application" on page 4.

 **Installation and startup may only be performed by technically trained, skilled persons who are familiar with the associated risks and warranty provisions.**

9.4.1 Initial startup

Prerequisites: The controller must be correctly installed and connected (↪ section 8 "Installation" on page 12). Proceed as follows to start up the controller for the first time:

1. Switch off the line voltage and verify that all circuits are deenergized.
2. The supply voltage specified on the nameplate of the controller must be identical to the line voltage that is present in the plant or machine. The line frequency is automatically detected by the temperature controller in the range from 47 to 63Hz.
3. In the case of controllers manufactured up to March 2005, the settings of the DIP switches on the controller are indicated in the ROPEX Application Report and depend on the heatsealing band that is used (section 9.2 "Controller configuration" on page 19).
4. Make sure that no START signal is present.
5. Apply the auxiliary voltage (24VDC).
6. Switch on the line voltage.
7. When the voltage is switched on, the yellow "AUTOCAL" LED lights up for approximately 0.3 seconds to indicate that the controller is being powered up correctly.

 **As of SW-Revision 106:**
If the red "ALARM" LED lights up for 0.3s in addition to the yellow "AUTOCAL" LED when the voltage is switched on, the configuration of this controller has been changed in the visualization software (↪ section 10.11 "Diagnostic interface/ visualization software (as of April 2005)" on page 31). In order to avoid malfunctions, please check the controller configuration before continuing the startup procedure.

8. One of the following states then appears:

| "ALARM" LED | "OUTPUT" LED | ACTION |
|-------------------|-------------------------|------------------------------------|
| OFF | Short pulses every 1.2s | Go to 9 |
| BLINKS fast (4Hz) | OFF | Go to 9 |
| Lit continuously | OFF | Fault diagnosis (↪ section 10.1 3) |

9. Activate the AUTOCAL function while the heatsealing band is still cold (terminals 5+14). The yellow "AUTOCAL" LED lights up for the duration of the calibration process (approx. 10...15s). A voltage of app. 0V appears at the same time at the actual value output (terminals 17+14). If an ATR-x is connected, it indicates 0...3°C.

When the zero point has been calibrated, the "AUTOCAL" LED goes out and a voltage of 0.66V (300°C range) or 0.4V (500°C range) appears at the actual value output instead. If an ATR-x is connected, it must be set to "Z".

If the zero point has not been calibrated successfully, the red "ALARM" LED blinks slowly (1Hz). In this case the controller configuration is incorrect (↪ section 9.2 "Controller configuration" on page 19 and ROPEX Application Report). Repeat the calibration after the controller has been configured correctly.

10. When the zero point has been calibrated successfully, set a defined temperature at the set point input (terminal 16) and apply the "START" signal (HEAT). The "HEAT" LED then lights up. The heating and control process can be observed at the actual value output:

The controller is functioning correctly if the temperature (which corresponds to the signal change at the analog output) follows a harmonious

curve, in other words it must not jump abruptly, fluctuate or deviate temporarily in the wrong direction. This kind of behavior would indicate that the U_R measuring wires have been laid incorrectly. If an error message is displayed, please proceed as described in section 10.13 "Error messages" on page 32.

11. Burn in the heatsealing band (↪ section 9.3.2 "Burning in the heatsealing band" on page 21) and repeat the AUTOCAL function.

The controller is now ready

9.4.2 Restart after replacing the heatsealing band

To replace the heatsealing band, proceed as described in section 9.3.2 "Burning in the heatsealing band" on page 21 .

 **Always use a heatsealing band with the correct alloy, dimensions and copper-plating in order to avoid malfunctions and overheating.**

Continue with section 9.4.1, steps 4 to 11.

10 Controller functions

See also section 8.6 "Auxiliary voltage" on page 16.

10.1 Indicators and controls

Manufactured as of April 2005

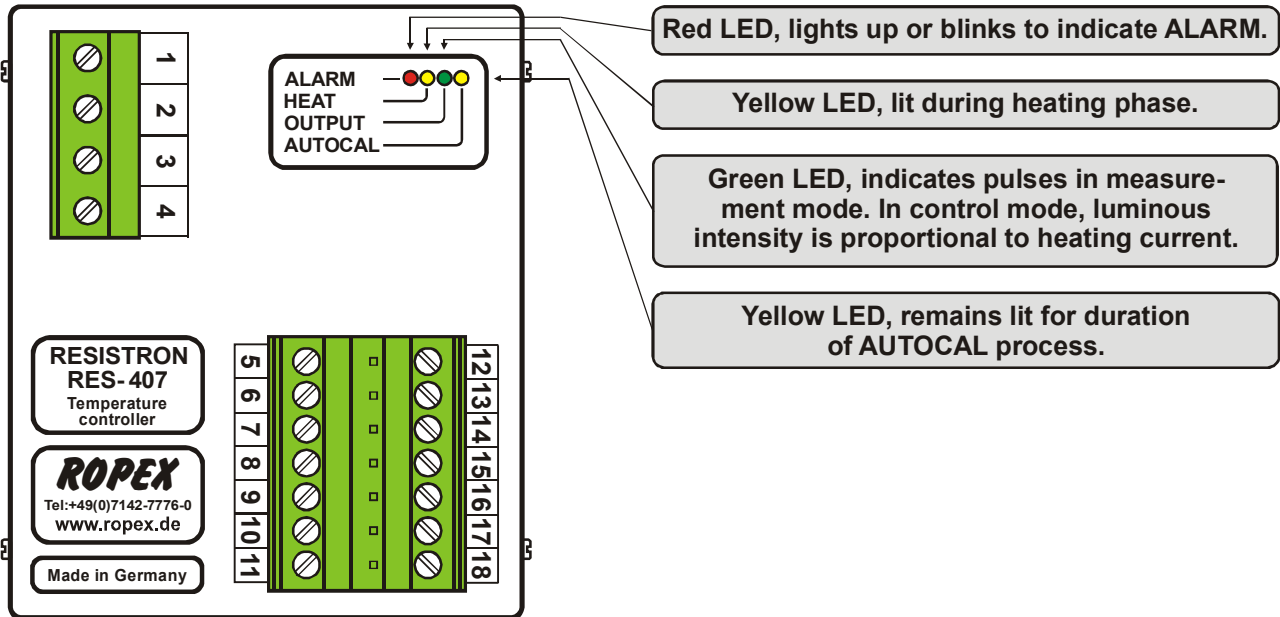

Manufactured up to March 2005

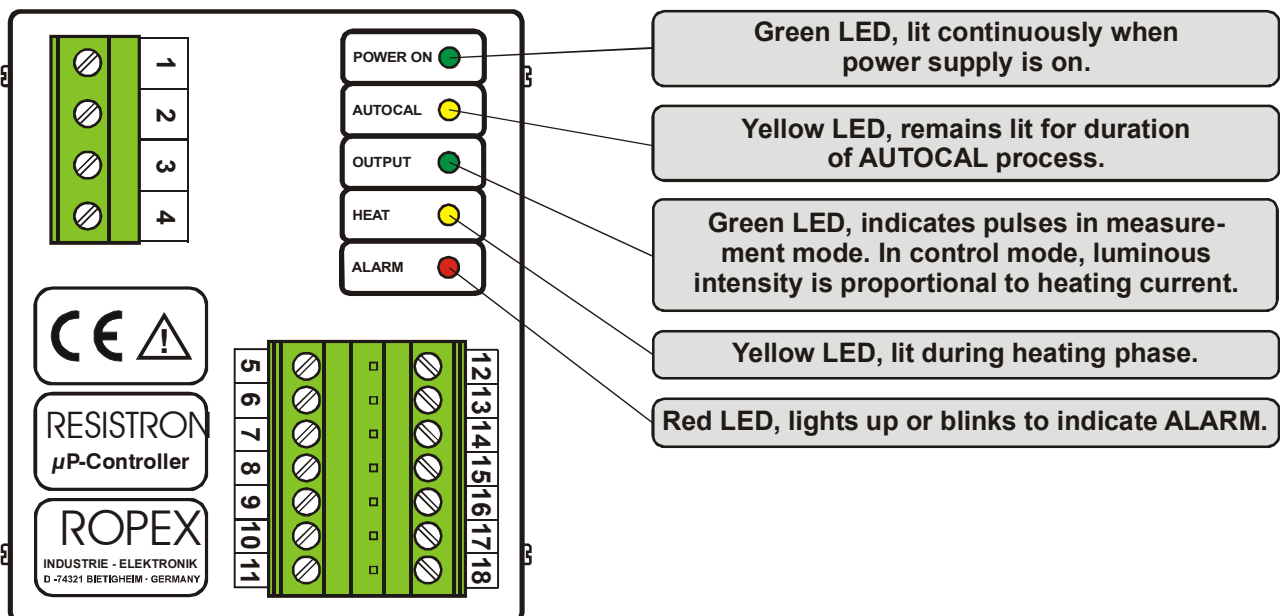

In addition to the functions shown in the diagram above, various controller operating states are indicated by the LEDs. These states are described in detail in the table below:

| LED | Blinks slowly (1Hz) | Blinks fast (4Hz) | Lit continuously |
|----------------------------|--|--|------------------------|
| AUTOCAL (yellow) | RESET active, START and AUTOCAL functions are locked (as of April 2005) | AUTOCAL requested, but function is locked (as of April 2005) | AUTOCAL executing |
| HEAT (yellow) | — | HEAT requested, but function is locked (as of April 2005) | START executing |
| OUTPUT (green) | In control mode the luminous intensity is proportional to the heating current. | | |
| ALARM (red) | Configuration error, AUTOCAL not possible | Controller calibrated incorrectly, run AUTOCAL | Fault, ↪ section 10.13 |

10.2 Temperature setting (set point selection)

The heatsealing temperature of the RES-407 can be set in two ways:

- By applying a 0...10VDC voltage to the analog input terminals 16 + 14:

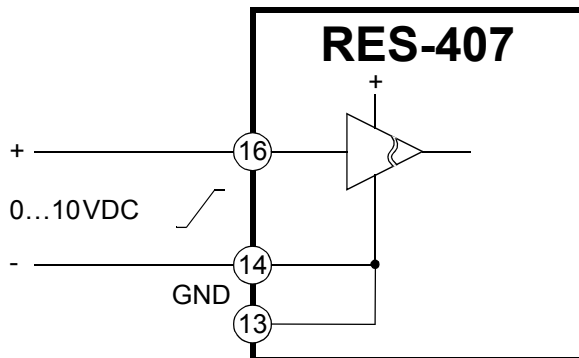

The relationship between the applied voltage and the SET temperature is linear.

Setting range:

0VDC → 0°C

10VDC → 300°C or 500°C

(depending on the contr. configuration)

Please refer to section 10.3 "Temperature indication (actual value output)" on page 26 for a circuit diagram.

- By connecting a 2kohm potentiometer to terminals 14...16:

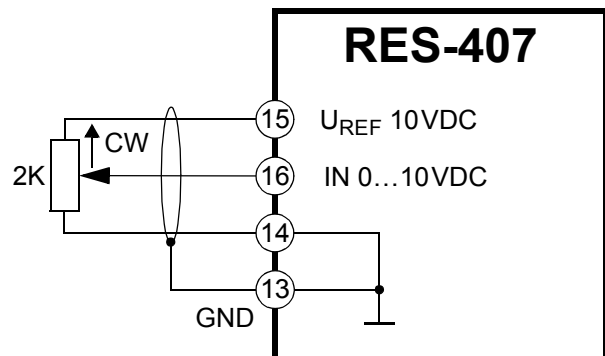

Potentiometer with digital dial PD-x

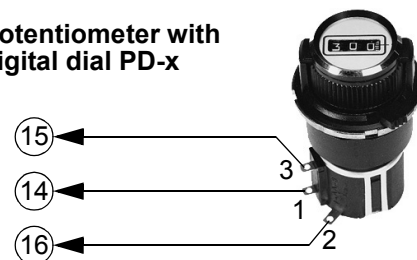

In order to be able to select the set point with a potentiometer, the controller makes a +10VDC (±5%) reference voltage available at terminal 15.

The relationship between the potentiometer setting and the SET temperature is linear.

The connecting wires between the controller and the potentiometer must be shielded.

If a ROPEX PD-x precision potentiometer is used, the SET temperature can be adjusted exactly with the help of the digital display in the window of the dial. The number which appears on the display corresponds to the SET temperature in °C.

The set point that is selected for the heatsealing temperature must be greater than 40°C. If not, the heatsealing band will not be heated up when the "START" signal is activated.

! If a potentiometer is not connected or if 0VDC is applied to the set point input, the set point is assumed to be zero. When you connect the potentiometer, please note the direction of rotation!

10.3 Temperature indication (actual value output)

The RES-407 supplies an analog 0...10VDC signal, which is proportional to the real ACTUAL temperature, at terminals 17+14.

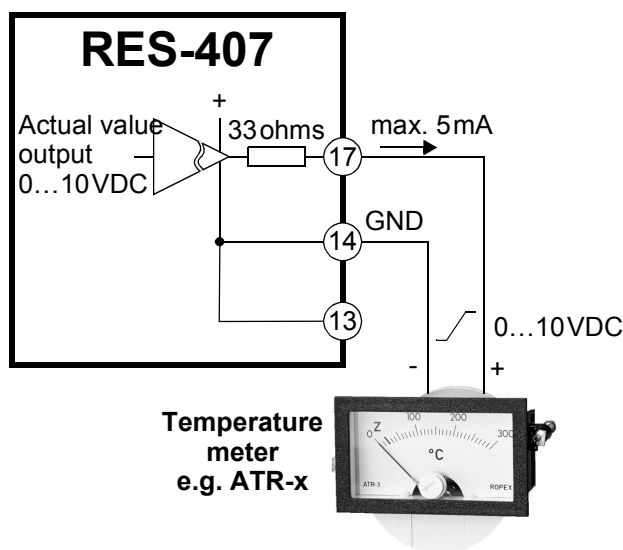

Voltage values:
 0VDC → 0°C
 10VDC → 300°C or 500°C
 (depending on the contr. configuration)

The relationship between the change in the output voltage and the ACTUAL temperature is linear.

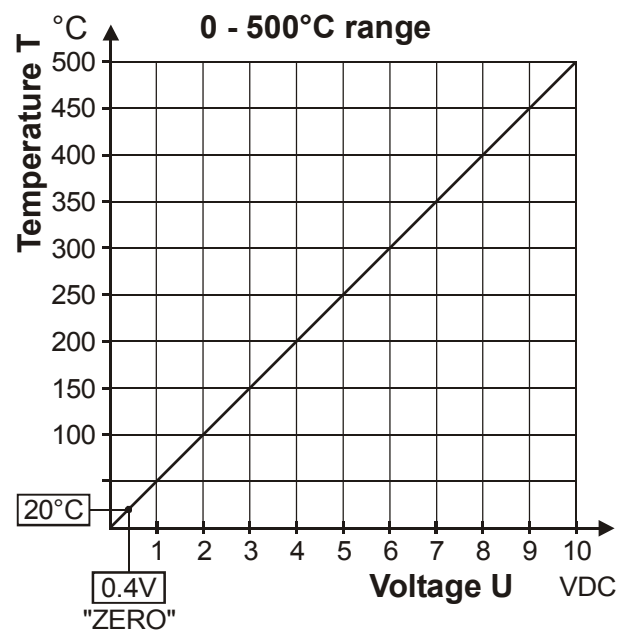
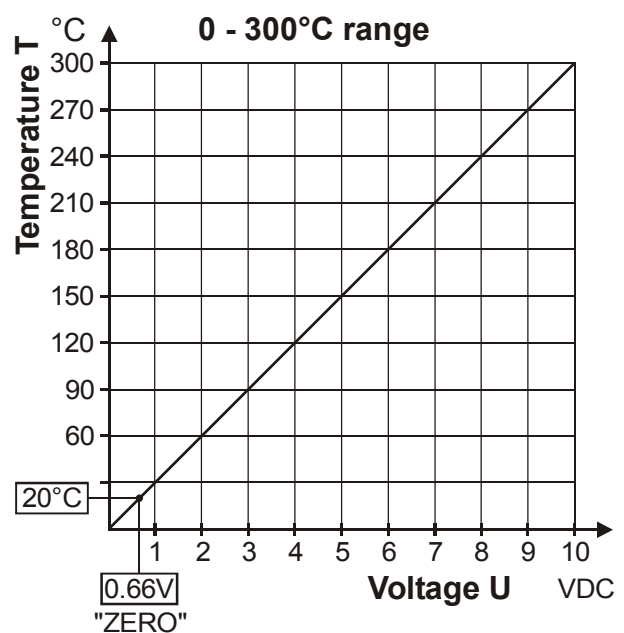

An indicating instrument can be connected to this output in order to visualize the temperature of the heatsealing band.

The characteristics of the ROPEX ATR-x temperature meter (size, scaling, dynamic response) are ideally suited to this application and this instrument should therefore always be used (↪ section 5 "Accessories and modifications" on page 6).

It not only facilitates SET-ACTUAL comparisons, but also enables other criteria such as the heating rate, set point reached within the specified time, cooling of the heatsealing band etc. to be evaluated.

This meter moreover permits disturbances in the control loop (loose connections, contacting or wiring problems) as well as any line disturbances to be

observed extremely effectively and interpreted accordingly. The same applies if mutual interference occurs between several neighboring control loops.

! If an alarm is signaled, this analog output is used to display a selective error message (↪ section 10.13 "Error messages" on page 32).

10.4 Automatic zero calibration (AUTOCAL)

Owing to the automatic zero calibration (AUTOCAL) function, there is no need to adjust the zero point manually on the controller. This function matches the controller to the current and voltage signals that are present in the system. The zero point is calibrated in the factory to the initial temperature (ambient temperature, 20°C).

Variable initial temperature:

On controllers manufactured as of April 2005, the initial temperature for the "AUTOCAL" function can be set in the 0...+40°C range in the visualization software (↪ section 10.11 "Diagnostic interface/visualization software (as of April 2005)" on page 31). This setting is remembered if the controller is switched off and then on again.

As of SW Revision 107, the "External calibration temperature" setting can also be selected in the visualization software. The initial temperature for this setting can be specified in the +3...+40°C range via the analog input (terminals 16+14) (↪ section 10.2 "Temperature setting (set point selection)" on page 25). The value selected at the analog input must be present when the "AUTOCAL" function is activated.

If the specified temperature is too high (greater than 40°C) or if the selected value varies, an error message appears (error codes 115 and 116; ↪ section 10.13 "Error messages" on page 32).

The "AUTOCAL" function is activated by means of a 24VDC pulse at terminals 5+14.

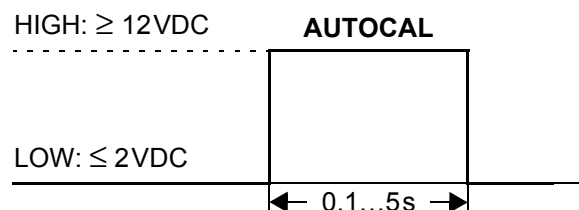
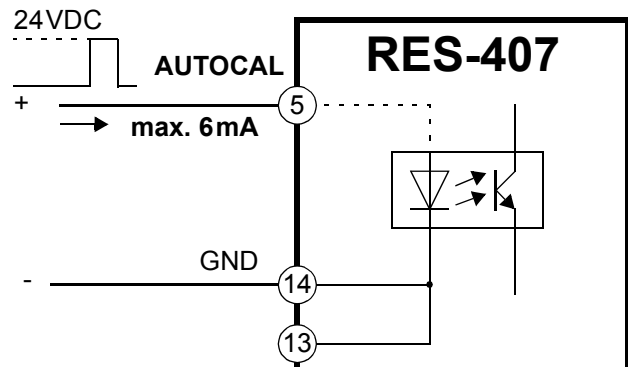

The automatic calibration process takes around 10...15seconds. The heatsealing band is not heated during this process.

The yellow LED on the front panel lights up when the "AUTOCAL" function is active. The actual value output (terminals 14+17) is 0...3°C (corresponds to app. 0VDC).

If the temperature of the heatsealing band varies on controllers manufactured as of April 2005, the "AUTOCAL" function is executed a maximum of three times. If the function still cannot be terminated successfully, an error message appears (↪ section 10.13 "Error messages" on page 32).

! You should always wait for the heatsealing band and the bar to cool down (to ambient temperature) before activating the "AUTOCAL" function.

Reasons for disabled "AUTOCAL" function:

1. The "AUTOCAL" function cannot be activated until 10seconds after the controller is switched on. If you attempt to activate it sooner, it will not work.
2. The "AUTOCAL" function cannot be not activated if the heatsealing band cools down at a rate of more than 0.1K/s. If the control signal is activated, the function is executed automatically providing the cooling rate has fallen below the above-mentioned value.

3. If the "START" signal (24VDC) is active, the "AUTOCAL" function is not executed ("HEAT" LED lit).
4. If the "RESET" signal (24VDC) is active, the "AUTOCAL" function is not executed.
5. The "AUTOCAL" function cannot be activated if error codes 101...103, 201...203, 801 or 9xx (up to March 2005: error codes 1...3, 5...7) occur on startup (↪ section 10.13 "Error messages" on page 32). If the controller has already operated correctly - at least once - after starting up, the "AUTOCAL" function cannot be activated with error codes 201...203, 801 or 9xx (up to March 2005: error codes 5...7).

10.5 "START" signal (HEAT)

When the "START" signal is activated, the controller-internal set/actual comparison is enabled and the heatsealing band is heated up to the SET temperature. It remains at this temperature until the signal is deactivated again.

The "HEAT" LED on the front panel of the RES-407 is lit continuously for the duration of the heating phase.

The "START" signal is activated by means of a 24VDC signal at terminals 6+14.

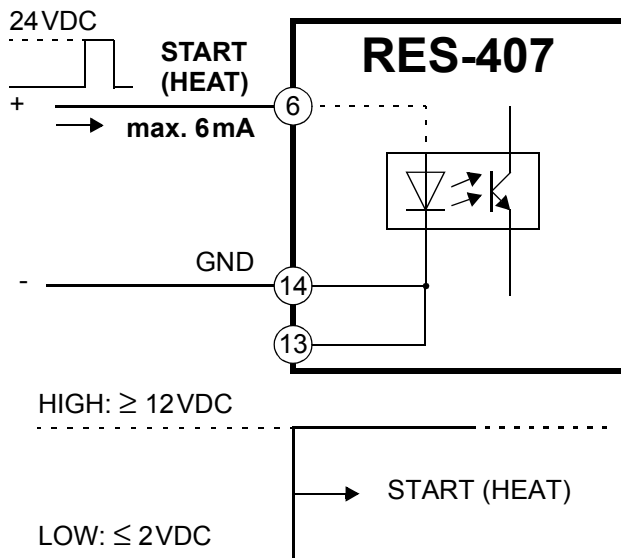

! The "START" signal is disabled as long as the "AUTOCAL" function is executing or the "RESET" signal is active.

The set point that is selected for the heatsealing temperature must be greater than 40°C. If not, the heatsealing band will not be heated up.

The alarm output is switched if the "START" signal is activated while an error message is indicating error codes 104...106, 111...114, 211, 302 or 303 (up to March 2005: error codes 8...12) (↪ section 10.13 "Error messages" on page 32). The heatsealing band is no longer heated up.

10.6 "RESET" signal

The RESISTRON temperature controller RES-407 can be reset by means of an external "RESET" signal at terminals 7+14). As a result:

- A heatsealing cycle is aborted if one is in progress
- No more measuring impulses are generated
- An error message is reset if one is present (Note: The error message is not reset until the "RESET" signal is deactivated)

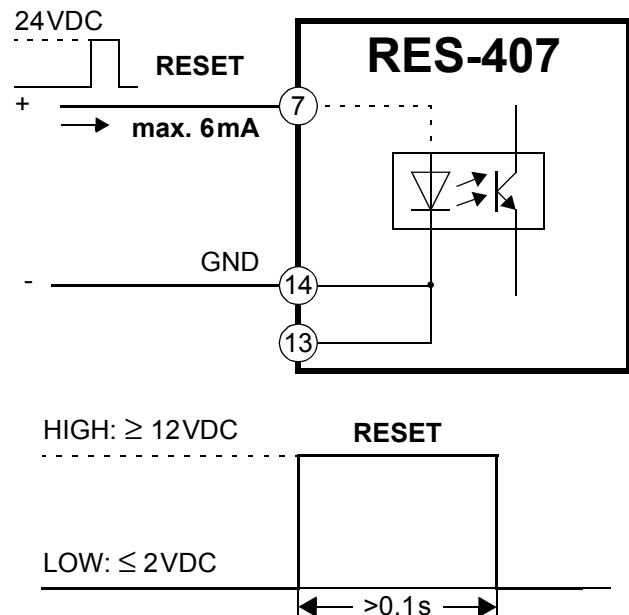

As of SW revision 103, the controller actual value output changes to 0...3°C (i.e. approximately 0VDC) while the "RESET" signal is being activated. This may be interpreted by the higher-level controller (e.g. a PLC) as feedback.

The "AUTOCAL" function is not aborted if the "RESET" signal is activated while it is still executing.

! The controller performs an internal initialization run lasting approximately 500ms after the "RESET" signal is deactivated. The next heatsealing process cannot be started until it has finished.

! If a contactor Kb is used to deactivate the control loop (↪ section 8.3 "Power supply" on page 14), it must be energized again 50ms at the latest after the "RESET" signal is deactivated. If it is energized too late, an error message will be output by the controller.

10.7 Measuring impulse duration (as of April 2005)

The length of the measuring impulses generated by the controller can be set with the parameter. It may be necessary to set a measuring impulse that is longer than the default 1.7ms for certain applications (↪ ROPEX Application Report).

! This parameter can only be set by means of the ROPEX visualization software (↪ section 10.11 "Diagnostic interface/ visualization software (as of April 2005)" on page 31).

10.8 Automatic phase angle compensation (AUTOCOMP) (as of April 2005)

It may be necessary to compensate the phase angle displacement between the U_R and I_R measuring signals for special heatsealing applications (↪ ROPEX Application Report). The "AUTOCOMP" function is provided for this purpose. The following settings are possible:

1. **„OFF" (Factory settings)**

The „AUTOCOMP" function is deactivated.

2. **„ON"**

The „AUTOCOMP" function is executed whenever the "AUTOCAL" function (↪ section 10.4 "Automatic zero calibration (AUTOCAL)" on page 27) is run twice in quick succession. The interval between the end of the first "AUTOCAL" function and the start of the second "AUTOCAL" function must be shorter than 2.0s. The second "AUTOCAL" function only takes around 2.0s and incorporates the "AUTOCOMP" function.

If the interval between the two "AUTOCAL" functions is longer than 2.0s, "AUTOCAL" is executed normally again the second time.

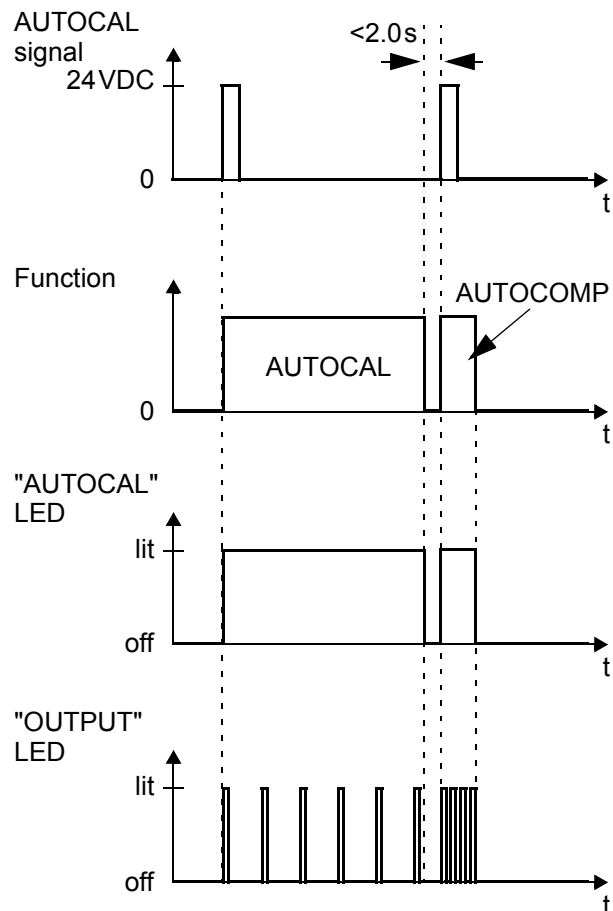

The "OUTPUT" LED blinks repeatedly when the "AUTOCOMP" function is executed and the actual value output (terminals 17+14) is set to 0...3°C (i.e. app. 0VDC).

3. **„AUTO"**

(as of software revision 108)

With this setting the „AUTOCOMP" function is activated automatically after the "AUTOCAL" function has been successfully executed.

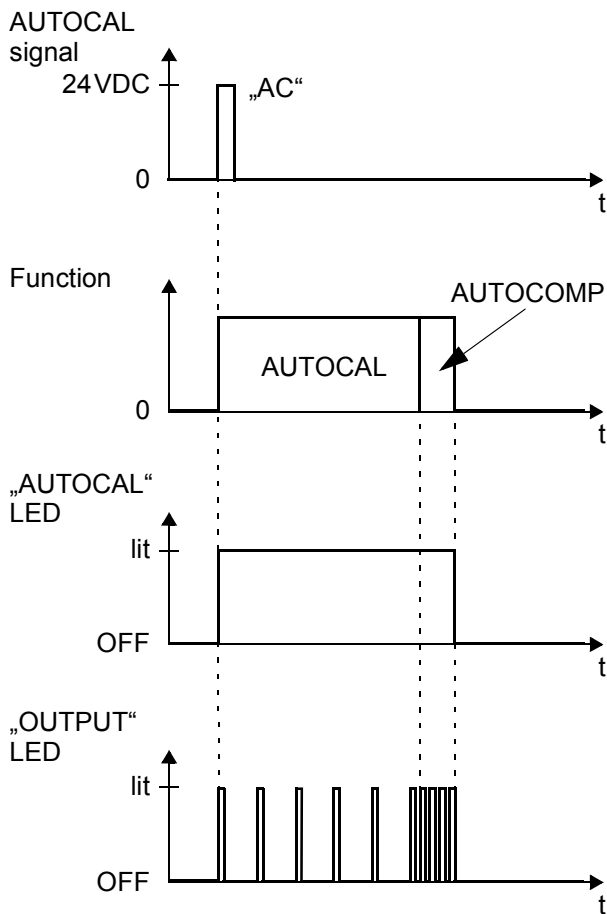

The "OUTPUT" LED blinks repeatedly when the "AUTOCOMP" function is executed and the actual value output (terminals 17+14) is set to 0...3°C (i.e. app. 0VDC).

⚠ The "AUTOCOMP" function must be activated in the ROPEX visualization software (↪ section 10.11 "Diagnostic interface/visualization software (as of April 2005)" on page 31) (default setting: AUTOCOMP off).

10.9 Temperature diagnosis (as of April 2005)

An additional temperature diagnosis can be activated in the ROPEX visualization software (↪ section 10.11 "Diagnostic interface/visualization software (as of April 2005)" on page 31). The RES-407 checks whether the ACTUAL temperature is within a settable tolerance band ("OK" window) on either side of the SET

temperature. The lower ($\Delta\vartheta_{lower}$) and upper ($\Delta\vartheta_{upper}$) tolerance band limits are configured in the factory to -10K and +10K. These values can be set independently of one another in the ROPEX visualization software.

If the actual temperature is inside the specified tolerance band when the "START" signal is activated, the temperature diagnosis is activated as well. If the ACTUAL temperature leaves the tolerance band, the corresponding error code (307 or 308) is indicated and the alarm output is switched (↪ section 10.13 "Error messages" on page 32).

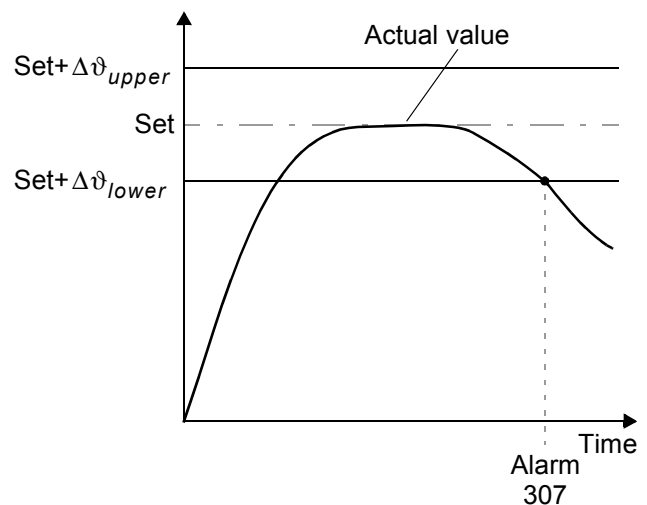

If the temperature diagnosis is not activated by the time the "START" signal is deactivated (i.e. if the ACTUAL temperature does not exceed the upper or lower tolerance band limit), the corresponding error code (309, 310) is indicated and the alarm output is switched.

An additional delay time (0...9.9s) can be set in the ROPEX visualization software. The first time the lower tolerance band limit is exceeded, the temperature diagnosis is not activated until the parameterized delay time has elapsed. The temperature diagnosis function can thus be explicitly deactivated, e.g. if the temperature drops temporarily owing to the closure of the sealing jaws.

⚠ The values that can be set in the ROPEX visualization software for the upper and lower tolerance band are identical to those for the "Temperature OK" signal (MOD 46).

10.10 Heatup timeout (as of April 2005)

An additional heatup timeout can be activated in the ROPEX visualization software (↪ section 10.11 "Diagnostic interface/visualization software (as of April 2005)" on page 31).

This timeout starts when the START signal is activated. The RES-407 then monitors the time required for the ACTUAL temperature to reach 95% of the SET temperature. If this time is longer than the parameterized time, the corresponding error code (304) is indicated and the alarm output is switched (↪ section 10.13 "Error messages" on page 32).

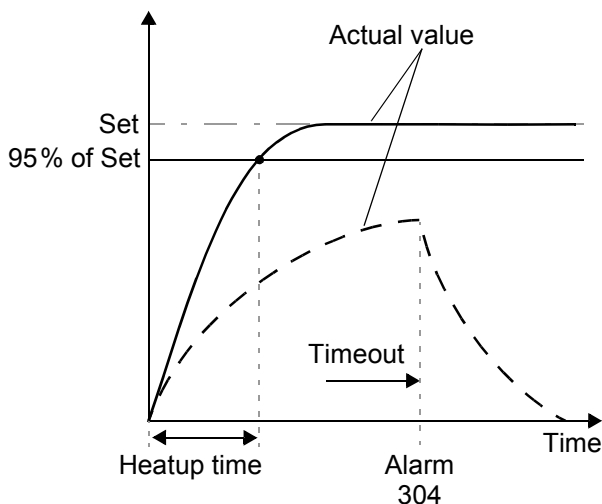

10.11 Diagnostic interface/visualization software (as of April 2005)

An interface with a 6-pole Western socket is provided for systemdiagnostics and process visualization. This interface allows a data connection to be set up to the ROPEX visualization software using the ROPEX communication interface CI-USB-1.

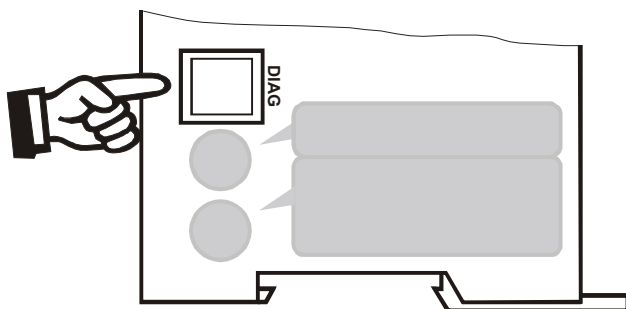

⚠ Only a ROPEX communication interface is allowed to be connected to the diagnostic interface. Connecting another device (e.g. a telephone cable) could result in malfunctions or damage to the controller.

The ROPEX visualization software is described in a separate document.

10.12 System monitoring/alarm output

To increase operating safety and to avoid faulty heatsealing, this controller incorporates special hardware and software features that facilitate fault diagnosis and selective error messages. Both the external wiring and the internal system are monitored. These features assist the operator in identifying the cause of abnormal operations.

A system fault is reported or differentiated by means of the following indications:

A.) Red "ALARM" LED on the controller with three states:

1. **Blinks fast (4Hz):**
The "AUTOCAL" function should be executed (error codes 104...106, 211, 302, 303; up to March 2005: error codes 8+9).
2. **Blinks slowly (1Hz):**
The system configuration is incorrect and the zero calibration ("AUTOCAL" function) was unsuccessful (↪ section 9.2 "Controller configuration" on page 19). It corresponds to error codes 110...114 (up to March 2005: error codes 10...12).
3. **Lit continuously:**
A fault is preventing the controller from being started (error codes 101...103, 107, 108, 201...203, 307, 308, 801, 9xx; up to March 2005: error codes 1...7). Also in instances 1 and 2 if the "START" signal is activated simultaneously.
As a rule, it refers to an external wiring fault.

B.) Alarm output signal on the controller (terminals 12+18):

This logic output is set in the factory as follows:

- **LOW (OPEN)** in operating states A.1) and A.2), but high (closed) if a "START" signal is activated in one of these states.
- **HIGH (CLOSED)** in operating state A.3)

If the alarm relay is configured opposite to the factory setting (↳ section 9.2.3 "Configuration of the alarm output (as of April 2005)" on page 21), these states are reversed.

C.) Error code output via the 0 to 10V DC actual value output (terminals 17+14):

Since a temperature indication is no longer necessary if a fault occurs, the actual value output is used to display error messages in the event of an alarm.

13 voltage levels (up to March 2005: 12 voltage levels) are offered for this purpose in the 0...10VDC range, each of which is assigned an error code (↳ section 10.13 "Error messages" on page 32).

If a state that requires "AUTOCAL" occurs - or if the controller configuration is not correct - (error codes 104...106, 111...114, 211, 302, 303; up to March 2005: error codes 8...12), the actual value output jumps back and forth at 1Hz between the voltage value which corresponds to this error and the end of the scale (10V DC, i.e. 300°C or 500°C). If the "START" signal is activated in one of these states, the voltage value does not change any more.

Selective fault detection and indication can thus be implemented simply and inexpensively using the analog input of a PLC with a corresponding error message (↳ section 10.13 "Error messages" on page 32).

 An alarm can only be reset by applying a "RESET" signal or by switching the controller off and then on again.

 If an error message is reset using the "RESET" signal, the "RESET" signal must be deactivated first.

 Invalid error messages may appear when the controller is switched off owing to the undefined operating state. This must be taken into account when they are evaluated by the higher-level controller (e.g. a PLC) in order to avoid false alarms.

10.13 Error messages

The table below shows how the analog voltage values that appear at the actual value output correspond to the faults that have occurred. It also describes each fault and the required corrective action.

The error messages are listed in two separate tables for controllers "up to March 2005" and "as of April 2005". The block diagram in section 10.14 "Fault areas and causes" on page 37 permits each fault to be cleared quickly and efficiently.

13 voltage levels for fault diagnostics appear at the actual value output of all controllers manufactured as of April 2005. The error messages are differentiated even more finely in the controller. The error codes described below can be displayed with the ROPEX visualization software (↳ section 10.11 "Diagnostic interface/ visualization software (as of April 2005)" on page 31) to facilitate troubleshooting.

 If the actual value output is evaluated in order to identify an error message - in the higher-level controller, for instance - the tolerance window must be adjusted to prevent it from being incorrectly interpreted. Please note the tolerances of the actual value output (↳ section 6 "Technical data" on page 10).

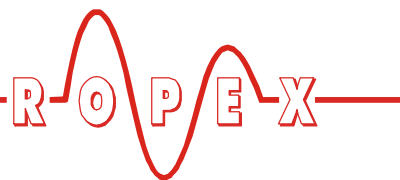

| Part 1 of 3: Error messages as of April 2005 | | | | | | | | | |
|--|--------------------------------|-------------------|-------------------|------------------|--------------------------------------|---|--|--|--|
| Error code | Act. value output; Voltage [V] | Temp. 300 °C [°C] | Temp. 500 °C [°C] | ALARM LED | STATUS of alarm outp. (factory set.) | Cause | Action if machine started for first time | Action if machine already operating, HS band not chang. | |
| 1 (101) | 0.66 | 20 | 33 | Lit continuously | HIGH | I _R signal missing | Fault area ① | Fault area ① | |
| 2 (102) | 1.33 | 40 | 66 | | | U _R signal missing | Fault area ③ | Fault area ③ | |
| 3 (103) | 2.00 | 60 | 100 | | | U _R and I _R signals missing | Fault area ② | Fault area ②⑨ | |
| (107) (108) | | | | | | Temperature step, down Temperature step, up | Fault area ④⑤⑥ (loose contact) | Fault area ④⑤⑥ (loose contact) | |
| 4 (307) (308) (309) (310) | 2.66 | 80 | 133 | | | Temperature too low/high (☛ section 10.9) | | | |
| 5 (201) (202) (203) | 3.33 | 100 | 166 | | | Frequency fluctuation, inadmissible line frequency | Check power supply | Check power supply | |
| 6 (304) | 4.00 | 120 | 200 | | | Heatup time too long (☛ section 10.10) | Run RESET | Run RESET | |
| (901) (913) (914) (915) (916) | 4.66 | 140 | 233 | | | Int. faut, contr. defective Triac defective Int. faut, contr. defective Int. faut, contr. defective Int. faut, contr. defective | Replace controller Replace controller Replace controller Replace controller Replace controller | Replace controller Replace controller Replace controller Replace controller Replace controller | |
| (917) (918) | | | | | | Plug-in jumper for alarm output wrong | Check plug-in jumper | Check plug-in jumper | |

Part 2 of 3: Error messages as of April 2005

NOTE: The specified error messages are initially output as warnings (actual value output jumps back and forth between two values; alarm LED blinks; alarm output is LOW). When the "START" signal is activated, the warning changes to a fault (actual value output no longer jumps back and forth, see *bold italic values*; alarm LED lit continuously; alarm output is HIGH).

| Error code | Act. value output; Volt. [V] | Temp. 300 °C [°C] | Temp. 500 °C [°C] | ALARM LED | STATUS of alarm outp. (factory set.) | Cause | Action if machine started for first time | Action if machine already operating, HS band not chang. |
|------------|------------------------------|--------------------|--------------------|-------------------------------|---|--|--|---|
| 8 | (104) | | | | | I _R signals incorrect, incorrect specification of impulse-transformer | Run AUTOCAL , Check specification of transformer, Fault area ⑦ ⑧ | Fault area ④ ⑤ ⑥ (loose contact) |
| | (105) | | | Warning: Blinks fast (4Hz) | U _R signals incorrect, incorrect specification of impulse-transformer | | | |
| | (106) | ↕ 5.33 ↕ ↕ 10 ↕ | ↕ 160 ↕ ↕ 300 ↕ | ↕ 266 ↕ ↕ 500 ↕ | Warning: LOW | U _R and/or I _R signals incorrect, incorrect specification of impulse-transformer | | |
| | (302) | | | Fault: Lit continuously | Fault: HIGH (voltage value at actual value output then no longer changes) | Temperature too low, AUTOCAL wasn't performed, loose contact, ambient temp. fluctuates | Run AUTOCAL and/or fault area ④ ⑤ ⑥ (loose contact) | |
| | (303) | | | | temperature too high, AUTOCAL wasn't performed, loose contact, ambient temp. fluctuates | | | |
| 9 | ↕ 6.00 ↕ ↕ 10 ↕ | ↕ 180 ↕ ↕ 300 ↕ | ↕ 300 ↕ ↕ 500 ↕ | | Data error | Run AUTOCAL | --- | |

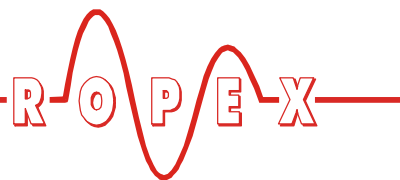

| Part 3 of 3: Error messages as of April 2005 | | | | | | | | | |
|---|------------------------------|--------------------|--------------------|---------------------------------|--|---|--|---|--|
| <p>NOTE: The specified error messages are initially output as warnings (actual value output jumps back and forth between two values; alarm LED blinks; alarm output is LOW). When the "START" signal is activated, the warning changes to a fault (actual value output no longer jumps back and forth, see bold italic values; alarm LED lit continuously; alarm output is HIGH).</p> | | | | | | | | | |
| Error code | Act. value output; Volt. [V] | Temp. 300 °C [°C] | Temp. 500 °C [°C] | ALARM LED | STATUS of alarm outp. (factory set.) | Cause | Action if machine started for first time | Action if machine already operating, HS band not chang. | |
| 10 (111) | ↕ 6.66 ↕ ↕ 10 ↕ | ↕ 200 ↕ ↕ 300 ↕ | ↕ 333 ↕ ↕ 500 ↕ | Warning: Blinks slowly (1Hz) | Warning: LOW | I _R signal incorrect, calibration not possible | Fault area ⑧, check configuration | --- | |
| 11 (112) | ↕ 7.33 ↕ ↕ 10 ↕ | ↕ 220 ↕ ↕ 300 ↕ | ↕ 366 ↕ ↕ 500 ↕ | | | | | | |
| 12 (113) | ↕ 8.00 ↕ ↕ 10 ↕ | ↕ 240 ↕ ↕ 300 ↕ | ↕ 400 ↕ ↕ 500 ↕ | | | | | | |
| (114) | | | | Fault: Lit continuously | Fault: HIGH (voltage value at actual value output then no longer changes) | U _R and I _R signals incorrect, calibration not possible | Fault area ⑦⑧, check configuration | --- | |
| 13 (115) | ↕ 8.66 ↕ ↕ 10 ↕ | ↕ 260 ↕ ↕ 300 ↕ | ↕ 433 ↕ ↕ 500 ↕ | | | | | | |
| (116) | | | | | | | | | |

| Error messages up to March 2005 | | | | | | | | | |
|---------------------------------|---------------------------------|--------------------|--------------------|---------------------|---|---|--|---|--|
| Error code | Act. value output ; Voltage [V] | Temp. 300 °C [°C] | Temp. 500 °C [°C] | ALARM LED | STATUS of alarm outp. (factory set.) | Cause | Action if machine started for first time | Action if machine already operating, HS-band not chang. | |
| 1 | 0.66 | 20 | 33 | Lit Continuously | HIGH | I _R signal missing | Fault area ① | Fault area ① | |
| 2 | 1.33 | 40 | 66 | | | U _R signal missing | Fault area ③ | Fault area ③ | |
| 3 | 2.00 | 60 | 100 | | | U _R and I _R signals missing | Fault area ② | Fault areas ②③ | |
| 4 | 2.66 | 80 | 133 | Lit Continuously | HIGH | Temperature step | Fault areas ④⑤⑥ (loose contact) | Fault areas ④⑤⑥ (loose contact) | |
| 5 | 3.33 | 100 | 166 | | | Frequency fluctuation, inadmissible line frequency | Check power supply | Check power supply | |
| 6 | 4.00 | 120 | 200 | Lit Continuously | HIGH | Internal fault | Run RESET | Run RESET | |
| 7 | 4.66 | 140 | 233 | | | Internal fault, controller defective | Replace controller | Replace controller | |
| 8 | ↔ 5.33 ↕ ↔ 10 ↕ | ↔ 160 ↕ ↔ 300 ↕ | ↔ 266 ↕ ↔ 500 ↕ | Blinks fast (4Hz) | LOW, gets HIGH with "START" signal (voltage value at analog output then no longer changes) | U _R and/or I _R signal incorrect | Run AUTOCAL | Fault areas ④⑤⑥ | |
| 9 | ↔ 6.00 ↕ ↔ 10 ↕ | ↔ 180 ↕ ↔ 300 ↕ | ↔ 300 ↕ ↔ 500 ↕ | Blinks slowly (1Hz) | | Data error | Run AUTOCAL | --- | |
| 10 | ↔ 6.66 ↕ ↔ 10 ↕ | ↔ 200 ↕ ↔ 300 ↕ | ↔ 333 ↕ ↔ 500 ↕ | | Blinks slowly (1Hz) | I _R signal incorrect, calibration not possible | Fault area ⑧, check configuration | --- | |
| 11 | ↔ 7.33 ↕ ↔ 10 ↕ | ↔ 220 ↕ ↔ 300 ↕ | ↔ 365 ↕ ↔ 500 ↕ | Blinks slowly (1Hz) | | U _R signal incorrect, calibration not possible | Fault area ⑦, check configuration | --- | |
| 12 | ↔ 8.00 ↕ ↔ 10 ↕ | ↔ 240 ↕ ↔ 300 ↕ | ↔ 400 ↕ ↔ 500 ↕ | | Blinks slowly (1Hz) | U _R and I _R signals incorrect, calibration not possible | Fault areas ⑦⑧, check configuration | --- | |

10.14 Fault areas and causes

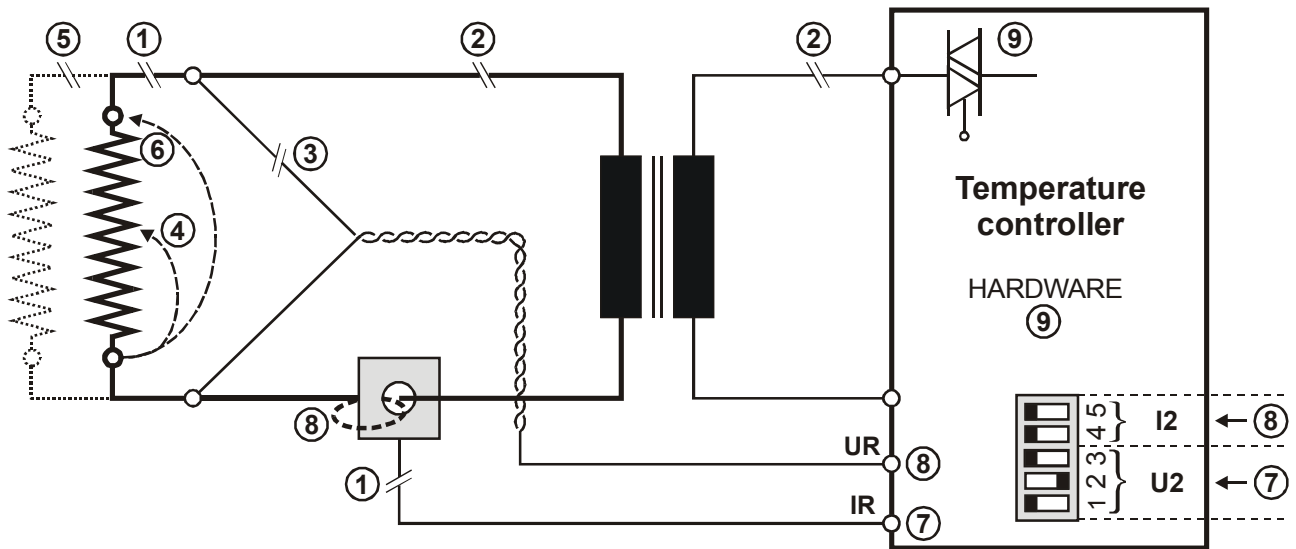



The table below explains the possible fault causes.



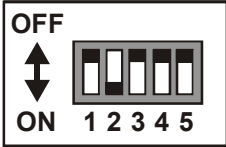
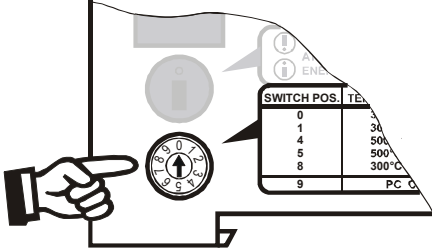
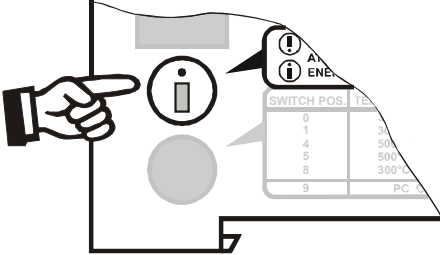

| Fault area | Explanation | Possible causes |
|------------|--|---|
| ① | Load circuit interrupted after U_R pickoff point | - Wire break, heatsealing band break - Contact to heatsealing band defective |
| | PEX-W2/-W3 current transformer signal interrupted | - I_R measuring wires from current transformer interrupted |
| ② | Primary circuit interrupted | - Wire break, triac in controller defective - Primary winding of impulse transformer interrupted |
| | Secondary circuit interrupted before U_R pickoff point | - Wire break - Secondary winding of impulse transformer interrupted |
| ③ | U_R signal missing | - Measuring wires interrupted |
| ④ | Partial short-circuit (ΔR) | - Heatsealing band partially bypassed by conducting part (clamp, opposite heatsealing bar etc.) |
| ⑤ | Parallel circuit interrupted | - Wire break, heatsealing band break - Contact to heatsealing band defective |
| ⑥ | Total short-circuit | - Heatsealing band installed incorrectly, insulation at heatsealing bar ends missing or incorrectly installed - Conducting part bypasses heatsealing band completely |
| ⑦ | U_R signal incorrect | - Up to March 2005: DIP switches 1 - 3 configured incorrectly (U_2 range) - As of April 2005: U_2 outside permissible range from 0.4...120VAC |

| Fault area | Explanation | Possible causes |
|------------|--|--|
| ⑧ | I_R signal incorrect | - Up to March 2005: DIP switches 4 + 5 configured incorrectly (I_2 range) - As of April 2005: I_2 outside permissible range from 30...500A |
| | Turns through PEX-W2/-W3 current transformer incorrect | - Check number of turns (two or more turns required for currents < 30A) |
| ⑨ | Internal controller fault | - Hardware fault (replace controller) - Plug-in jumper for alarm output not connected or incorrectly connected |

11 Factory settings

The RESISTRON temperature controller RES-407 is configured in the factory as follows:

| | | |
|---|---|--|
| <p><u>DIP switches</u> for secondary voltage U_2 and current I_2 (up to March 2005)</p> |  | <p>$U_2 = 6...60VAC$ $I_2 = 30...100A$</p> <p>DIP switches: 2 ON 1, 3, 4, 5 OFF</p> <p>These switches are automatically set by the AUTORANGE function on all controllers manufactured as of April 2005.</p> |
| <p><u>Rotary coding switch</u> for heatsealing band alloy and temperature range (as of June 2003)</p> |  | <p>Heatsealing band alloy: Alloy A20 Temperature range: 300°C Maximum temperature: 300°C</p> <p>Rotary coding switch: "0" position</p> |
| <p><u>Plug-in jumper</u> for alarm output (as of April 2005)</p> |  | <p>Output closes (HIGH) by alarm</p> |
| <p><u>Automatic phase angle compensation</u> (AUTOCOMP) [X]</p> |  | <p>AUTOCOMP: OFF</p> |

| | | |
|--|---|--|
| <p><u>Measuring impuse duration</u></p> <p>[X]</p> |  | <p>Measuring impulse length: 1,7ms</p> |
| <p><u>„Temp. OK“ signal</u> (as of April 2005: With MOD 46 only</p> <p>[X]</p> |  | <p>Tolerance band: -10K...+10K</p> |
| <p><u>Temperature diagnosis</u></p> <p>[X]</p> |  | <p>Temperature diagnosis: OFF</p> |
| <p><u>Heatup timeout</u></p> <p>[X]</p> |  | <p>Heatup timeout: OFF</p> |







[X] As of April 2005:
With ROPEX visualization software only.

12 Maintenance

The controller requires no special maintenance. Regular inspection and/or tightening of the terminals – including the terminals for the winding connections on

the impulse transformer – is recommended. Dust deposits on the controller can be removed with dry compressed air.

13 How to order

| | |
|---|--|
|  | <p>Contr. RES - 407 / . . . VAC</p> <ul style="list-style-type: none"> ↳ 115: Power supply 115VAC, Art. No. 740701 ↳ 230: Power supply 230VAC, Art. No. 740702 ↳ 400: Power supply 400VAC, Art. No. 740703 <p>Scope of supply: Controller includes connector plug-in parts (without current transformer)</p> <p>Modification MOD . . (optional, if required)</p> <ul style="list-style-type: none"> ↳ e.g. ↳ 01: MOD 01, Art. No. 800001 (amplifier for low voltage) ↳ 26: MOD 26, Art. No. 800026 (booster connection) ↳ 40: MOD 40, Art. No. 800040 ("Temperature OK" signal) <p>Please indicate the article numbers of the controller and the required modifications (optional) in all orders, e.g. RES-407/400VAC + MOD 26 (controller for 400VAC power supply with booster connection) Art. Nos. 740703 + 800026 must be ordered</p> |
|  | <p>Current transformer PEX-W3 Art. No. 885105</p> |
|  | <p>Line filter LF- . . 480</p> <ul style="list-style-type: none"> ↳ 06: Continuous current 6A, 480VAC, Art. No. 885500 ↳ 35: Continuous current 35A, 480VAC, Art. No. 885506 |
|  | <p>Impulse transformer</p> <p>See ROPEX Application Report for design and ordering information</p> |
|  | <p>Communication interface CI-USB-1 Art. No. 885650</p> |
|  | <p>Potentiometer PD- .</p> <ul style="list-style-type: none"> ↳ 3: For 300°C range, Art. No. 881103 ↳ 5: For 500°C range, Art. No. 881105 <p>Scope of supply: Potentiometer with digital dial</p> |
|  | <p>Temp. meter ATR- .</p> <ul style="list-style-type: none"> ↳ 3: 300°C range, Art. No. 882130 ↳ 5: 500°C range, Art. No. 882150 |

| | |
|---|---|
|  | <p>Booster B- . . . 400</p> <p>↘ → 075: Max. pulse load 75A, 400VAC, Art. No. 885301</p> <p>100: Max. pulse load 100A, 400VAC, Art. No. 885304</p> |
|---|---|

For more accessories: ↗ "Accessories" leaflet

14 Index

A

Accessories 6
 Actual value output 26
 Alarm output 11, 31
 Alarm relay 21
 Alloy 20, 23
 Ambient temperature 11
 Analog input 10
 Analog output 10
 Analog temperature meter 6
 Application 4
 Application Report 12, 15, 19
 AUTOCAL 6, 22, 27
 AUTOCOMP 29
 Automatic phase angle compensation 29
 Automatic zero calibration 6, 22, 27
 AUTOTUNE 6
 Auxiliary voltage 10, 16

B

Booster 7, 8, 41
 Burning in the heatsealing band 21, 23

C

Circuit breaker 14
 CI-USB-1 7, 31, 40
 Communication interface 7, 31, 40
 Controller configuration 19
 Controls 24
 Current transformer 7, 15, 40

D

Degree of protection 11
 Diagnostic interface 31
 Digital temperature meter 6
 Dimensions 12
 DIP switches 19

E

Error messages 32
 External switching amplifier 7

F

Factory settings 38
 Fault areas 37
 Fault diagnosis 6

H

HEAT 22, 28
 Heatsealing band type 10
 Heatup timeout 31
 How to order 40

I

Impulse heatsealing method 4
 Impulse transformer 7, 14, 40
 Installation 11, 12
 Installation procedure 12
 Installation regulations 12

L

Line filter 7, 14, 15, 40
 Line frequency 6, 10
 Line voltage 10, 40

M

Maintenance 39
 Measuring impulse duration 29
 Modifications 7, 17, 18, 40
 MODs 7, 17, 18, 40
 Monitoring current transformer 7

O

Overheating of heatsealing band 6

P

PEX-W2/-W3 3
 PEX-W3 15, 40
 Phase angle compensation 29
 Potentiometer 7, 25, 40
 Power dissipation 11
 Power supply 14
 Principle of operation 5

R

Reasons for locked "AUTOCAL" function 27
 Reference voltage 11
 Replacing the heatsealing band 21, 23
 "RESET" signal 28

S

Secondary current I_2 19
 Secondary voltage U_2 19
 Set point potentiometer 7, 25
 Set point selection 10, 25
 Signal „Temperatur erreicht“ 9
 "START" signal 22, 28
 Startup 19
 System diagnostics 31
 System monitoring 31

T

TCR 3, 21
 Technical data 10
 Temperature coefficient 3, 21

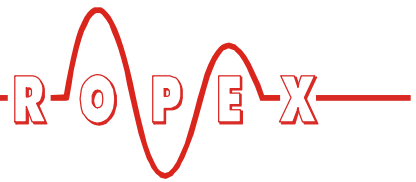

Temperature control 4
Temperature diagnosis 30
Temperature meter 6, 26, 40
Temperature OK signal 11, 18
Temperature range 10, 20
Temperature reached signal 8, 18
Temperature setting 25
Transformer 3, 7, 14, 40
Type of construction 10

V
View of the controller 19
Visualization software 31

W
Wiring 12, 14
Wiring diagram 16