

Internal Gear Pumps

Series QX

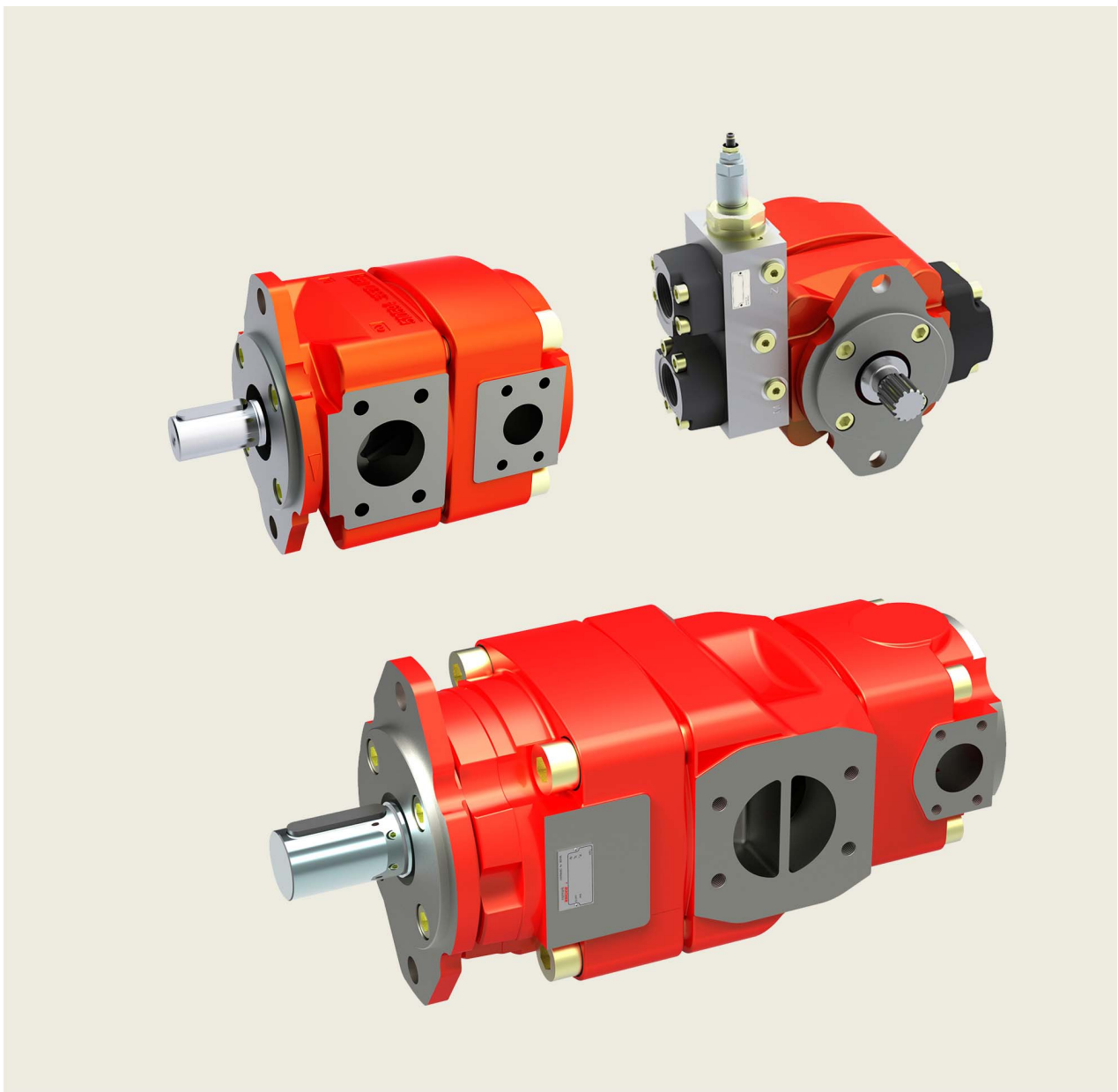

Contents	Page
1	General 5
1.1	Product description 5
1.2	Advantages 5
1.3	ATEX compliant explosion protection 5
2	Technical data 5
2.1	General (deviating values according manufacturer's specification) 5
2.2	Main characteristics for pressure range 1 6
2.3	Main characteristics for pressure range 2 7
2.4	Main characteristics for pressure range 3 7
2.5	Main characteristics for pressure range 4 8
3	Performance graphs 8
3.1	Noise level (Lp) 8
3.2	Efficiency (η) 9
3.3	Operation with variable-speed drives 10
4	Single pumps 11
4.1	Dimensions frame size 2 - 4 11
4.2	Dimensions frame size 5 - 8 12
4.3	Pressure range 1 13
4.4	Pressure range 2 13
4.5	Pressure range 3 14
4.6	Pressure range 4 14
4.7	Pressure range 4 with low-flow capability 15
4.8	Ordering code for single pumps 16
5	Double pumps 17
5.1	Selection table 17
5.2	Dimensions 18
5.3	Ordering code for double pumps 27
6	Triple pumps 28
6.1	Selection table 28
6.2	Ordering code for triple pumps 29
7	Low-flow capability pump in combination with other QX-single pumps 30
7.1	Dimensions 30
7.2	Ordering code 31

8	Fluid	32
9	Fluid cleanliness class	32
10	Operational reliability	32
11	Note	32
12	Accessories	33
	12.1 Bolt-on valves - SAE J518 code 61 / ISO 6162-1 pattern	33
	12.2 Pipe flanges - high pressure type	34
	12.3 Pipe flanges - low pressure type	35

1 General

1.1 Product description

The QX pumps are the 5th generation of Bucher internal gear pumps, which have proven themselves in thirty years of service around the world. Numerous improvements have been made to the straightforward and robust design.

Advances in the manufacturing process have made it possible without making higher demands on individual components to build pumps that are considerably lighter and more compact.

A new tooth profile, conceived and optimised with the help of CAE, has yielded another significant reduction in noise levels. Large sealing areas result in higher efficiencies.

The internal ring gear is supported by a hydrodynamic / hydrostatic lubrication film, which allows operation at low viscosities or low and high speeds. QX pumps are therefore suitable for use with variable speed drives, where they can provide variable flow rates.

1.3 ATEX compliant explosion protection

The internal gear pumps QX are suitable for application in hazardous areas and complies with the following guidelines:

ATEX directive	2014/34/EU
group	II
equipment category	3
atmosphere	G
temperature class	T3 and T4

1.2 Advantages

- extremely long service life
- volumetric efficiency up to 98%
- suitable for use with variable speed drivers
- can be used with fire resistant fluids (HFB, HFC and HFD = QXV), fuels, biodegradable and low-viscosity fluids
- certifications by ATEX 2, ABS, DNV, GL, LR, NK, ...
- low flow and pressure pulsations



II 3 G EEx c II T4
-20°C ≤ Ta ≤ +40°C



II 3 G EEx c II T3
-20°C ≤ Ta ≤ +80°C

2 Technical data

2.1 General (deviating values according manufacturer's specification)

General characteristics	Unit	Description, value
Installation attitude		unrestricted
Mounting method (standard)		oval 2-hole flange to ISO 3019/1 (SAE): QX 3-6 oval 2-hole flange to ISO 3019/2 (metric) QX 2+8
Direction of rotation		CW or CCW
Pump drive method		in-line, through a flexible coupling
Volumetric efficiency η_v		up to 98%
Fluids		HLP mineral oils to DIN 51524, Part, HFC fluids to VDMA 24317
Maximum admissible level of contamination of the hydraulic fluid		ISO 4406 code 20/18/15 (see section 9)
Operating viscosity	mm ² /s	10 ... 100 *
Starting viscosity		10 ... 300 * *other values on request
Fluid temperature range	°C	HLP-mineral oils -20 min. / +80 max. / HFC +50 max. range for max. long life cycle +30 ... +60 (considering viscosity field)
Inlet pressure maximum minimum	bar	1.5 absolute (without external drain connection) 0.5 ... 0.98 absolute (dependent on pump frame size and speed, see example in section 3.3.2)
Startup against pressure	bar	max. 20 (other values on request)
Seal material		NBR = standard, FKM (Viton) = option 09

IMPORTANT: The main characteristics are valid for hydraulic oils DIN 51524 with a viscosity of 20 ... 50mm²/s.
The operating pressure at the pump outlet side is specified also for fire-resistant fluids (HFC).

2.2 Main characteristics for pressure range 1

Displacement	Flow rate	Maximum speed	Code	Max. operating pressure at the pump outlet side				Torque	Power consumption
				continuous [bar]		intermittent [bar] ²⁾			
effective	1450 min ⁻¹ p = 0 bar								
[cm ³ /U] ¹⁾ [cm ³ /rev] ¹⁾	[l/min]	[rpm]		Mineral oil	HFC	Mineral oil	HFC	[Nm] ³⁾	[kW] ⁴⁾
10,3	14,9	3600	QX21-010	160	130	210	180	26	4,0
12,6	18,3	3600	QX21-012	125	100	160	135	25	3,8
15,9	23,0	3600	QX21-016	100	80	125	100	25	3,9
20,0	29,0	3000	QX31-020	160	130	210	180	51	7,7
25,3	36,7	3000	QX31-025	125	100	160	135	50	7,7
31,2	45,2	3000	QX31-032	100	80	125	100	50	7,5
40,7	59,0	3000	QX41-040	160	130	210	180	104	15,7
50,3	72,9	2600	QX41-050	125	100	160	135	100	15,2
64,7	93,8	2300	QX41-063	100	80	125	100	103	15,6
78,6	114	2300	QX51-080	160	130	210	180	200	30,4
101,1	146	2100	QX51-100	125	100	160	135	201	30,5
127,3	184	1800 ⁵⁾	QX51-125	100	80	125	100	203	30,8
160,5	232	1800 ⁶⁾	QX61-160	160	130	210	180	409	62,0
202,1	293	1800 ⁶⁾	QX61-200	125	100	160	135	402	61,0
249,7	362	1800 ⁶⁾	QX61-250	100	80	125	100	397	60,4
326,0	472	1750 ⁶⁾	QX81-315	160	130	210	180	830	126,0
402,6	583	1750 ⁶⁾	QX81-400	125	100	160	135	801	121,6
498,5	722	1500 ⁶⁾	QX81-500	100	80	125	100	793	120,5

1) Due to manufacturing tolerances, there may be slight variations in the displacement.

2) max. 20 second and not more than 10% of the duty cycle

3) theoretical value at the max. permitted continuous pressure for mineral oil

4) theoretical value at the max. permitted continuous pressures for mineral oil at n = 1450 rpm

5) for speeds > 1450 rpm, the min. permissible inlet pressure is 0.95 bar absolute. For HFC application a second suction port may be required

6) max. speed only possible with a second suction port, see section 2.2.1.

2.2.1 Suction arrangements for pump types QX61 and QX81

IMPORTANT: Minimum inlet pressure is 0.95 bar absolute with viscosity 10 ... 100 mm²/s (other values on request).

Type	Speed 1500 rpm Suction height		Speed 1800 rpm Suction height	
	up to 150 mm	over 150 mm	up to 150 mm	over 150 mm
QX61-160	I	I	I	II
QX61-200	I	I	I	II
QX61-250	I	II	II	II
QX81-315	I	II	II	II
QX81-400	II	II	II	-
QX81-500	II	II	-	-

I = standard pump with one suction port

II = model with two suction ports

All pump types coded II can be used without the second suction port up to 1200 rpm.

2.3 Main characteristics for pressure range 2

Displacement	Flow rate	Maximum speed	Code	Max. operating pressure at the pump outlet side				Torque	Power consumption
				effective		intermittent			
				[cm ³ /rev] ¹⁾	[l/min]	[rpm]	[bar]		
	1450 min ⁻¹ p = 0 bar			continuous	HFC	Mineral oil	HFC		
5,1 6,3 8,0	7,4 9,1 11,5	3600	QX22-005 QX22-006 QX22-008	210	180	250	210	17 21 27	2,6 3,2 4,0
10,0 12,6 15,6	14,5 18,3 22,6	3400	QX32-010 QX32-012 QX32-016	210	180	250	210	34 42 52	5,1 6,4 7,9
20,4 25,1 32,4	29,5 36,4 46,8	3200	QX42-020 QX42-025 QX42-032	210	180	250	210	68 84 108	10,4 12,7 16,5
39,3 50,6 63,7	56,9 73,2 92,1	2800	QX52-040 QX52-050 QX52-063	210	180	250	210	132 170 213	19,9 25,7 32,3
80,2 101,0 124,8	116 146 181	2500 ⁵⁾ 2300 ⁵⁾ 2000 ⁵⁾	QX62-080 QX62-100 QX62-125	210	180	250	210	268 338 417	40,7 51,2 63,4
163,0 201,3 249,2	236 291 361	1800 ⁵⁾ 1750 ⁵⁾ 1500 ⁵⁾	QX82-160 QX82-200 QX82-250	210	180	250	210	544 672 833	82,7 102,1 126,5

2.4 Main characteristics for pressure range 3

Displacement	Flow rate	Maximum speed	Code	Max. operating pressure at the pump outlet side				Torque	Power consumption
				effective		Intermittent			
				[cm ³ /rev] ¹⁾	[l/min]	[rpm]	[bar]		
	1450 min ⁻¹ p = 0 bar			continuous	HFC	Mineral oil	HFC		
5,1 6,3 8,0	7,4 9,1 11,5	3600	QX23-005 QX23-006 QX23-008	320	280	400	350	26 32 41	4,0 4,9 6,2
10,0 12,6 15,6	14,5 18,3 22,6	3400	QX33-010 QX33-012 QX33-016	320	280	400	350	51 64 80	7,7 9,7 12,1
20,4 25,1 32,4	29,5 36,4 46,8	3200	QX43-020 QX43-025 QX43-032	320	280	400	350	104 128 165	15,8 19,4 25,0
39,3 50,6 63,7	56,9 73,2 92,1	2800	QX53-040 QX53-050 QX53-063	320	280	400	350	200 258 321	30,4 39,1 49,3
80,2 101,0 124,8	116 146 181	2500 ⁵⁾ 2300 ⁵⁾ 2000 ⁵⁾	QX63-080 QX63-100 QX63-125	320	280	400	350	409 514 636	62,0 78,1 96,5
163,0 201,3 249,2	236 291 361	1800 ⁵⁾ 1750 ⁵⁾ 1500 ⁵⁾	QX83-160 QX83-200 QX83-250	320	280	400	350	830 1025 1270	126,0 155,7 192,7

1) Due to manufacturing tolerances, there may be slight variations in the displacement.

2) max. 20 second and not more than 10% of the duty cycle

3) theoretical value at the max. permitted continuous pressure for mineral oil

4) theoretical value at the max. permitted continuous pressures for mineral oil at n = 1450 rpm

5) for speeds > 1450 rpm, the min. permissible inlet pressure is 0.95 bar absolute. For HFC application a second suction port may be required

2.5 Main characteristics for pressure range 4

Displacement	Flow rate	Maximum speed	Code	Max. operating pressure at the pump outlet side				Torque	Power consumption
				continuous [bar]		Intermittent [bar] ²⁾			
effective	1450 min ⁻¹ p = 0 bar			Mineral oil	HFC	Mineral oil	HFC		
[cm ³ /rev] ¹⁾	[l/min]	[rpm]						[Nm] ³⁾	[kW] ⁴⁾
3,3 4,2	4,8 6,2	3600	QX24-003 QX24-004	320	280	400	350	17 21,5	2,6 3,2
5,1 6,3 8,0	7,4 9,1 11,5	3600	QX24-005 QX24-006 QX24-008	360	320	400	350	26 32 41	4,0 4,9 6,2
10,0 12,6 15,6	14,5 18,3 22,6	3600	QX34-010 QX34-012 QX34-016	360	320	400	350	51 64 80	7,7 9,7 12,1
20,4 25,1 32,4	29,5 36,4 46,8	3600	QX44-020 QX44-025 QX44-032	360	320	400	350	104 128 165	15,8 19,4 25,0
39,3 50,6 63,7	56,9 73,2 92,1	3000	QX54-040 QX54-050 QX54-063	340	280	400	350	200 258 321	30,4 39,1 49,3
80,2 101,0 124,8	116 146 181	2500 ⁵⁾ 2300 ⁵⁾ 2000 ⁵⁾	QX64-080 QX64-100 QX64-125	330	280	400	350	409 514 636	62,0 78,1 96,5
163,0 201,3 249,2	236 291 361	1800 ⁵⁾ 1750 ⁵⁾ 1500 ⁵⁾	QX84-160 QX84-200 QX84-250	330	280	400	350	830 1025 1270	126,0 155,7 192,7

1) Due to manufacturing tolerances, there may be slight variations in the displacement.

2) max. 20 second and not more than 10% of the duty cycle

3) theoretical value at the max. permitted continuous pressure for mineral oil

4) theoretical value at the max. permitted continuous pressures for mineral oil at n = 1450 rpm

5) for speeds > 1450 rpm, the min. permissible inlet pressure is 0.95 bar absolute.

3 Performance graphs

IMPORTANT: The performance graphs shown are valid for the specified pump models.
For other pump sizes, contact Bucher Hydraulics GmbH.

3.1 Noise level (L_p)

measured to DIN 45635, Part 26, in Stuttgart University's low-echo noise measurement chamber:
measurement distance 1 m
speed n = 1500 rpm
viscosity = 42 mm²/s

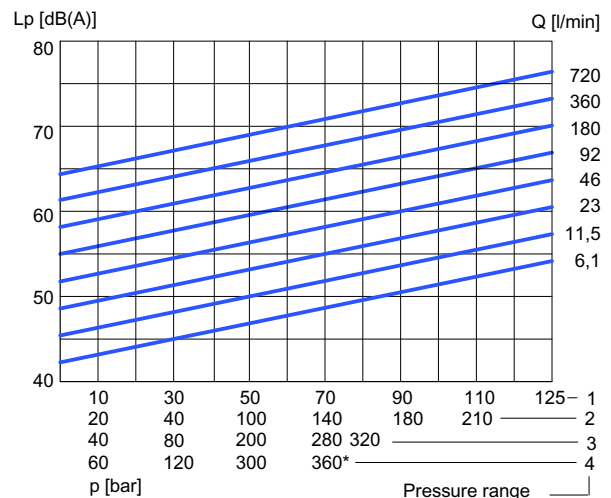

*Max. continuous operating pressure for pressure range 4 see section 2.5

3.2 Efficiency (η)

measured at speed 1450 rpm, viscosity 42 mm²/s

3.2.1 Pressure range 1

3.2.1.1 Volumetric efficiency

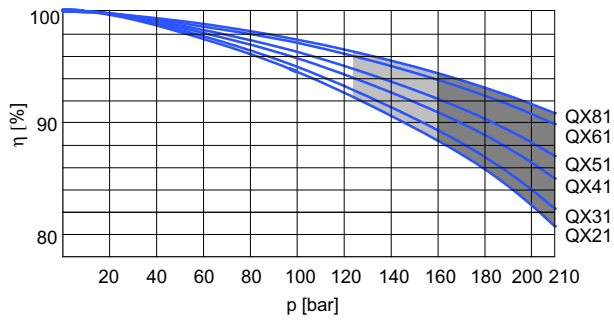

3.2.1.2 Hydromechanical efficiency

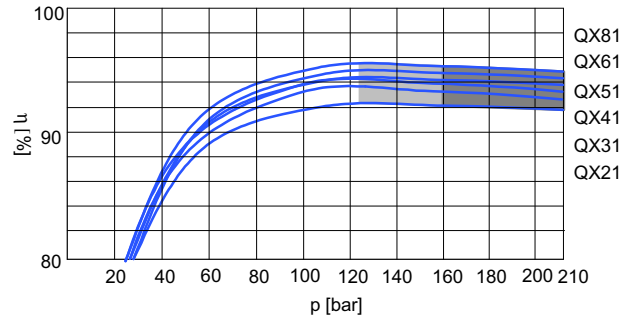

intermittent operating pressure as a function of displacement (see section 2.2)

3.2.2 Pressure range 2

3.2.2.1 Volumetric efficiency

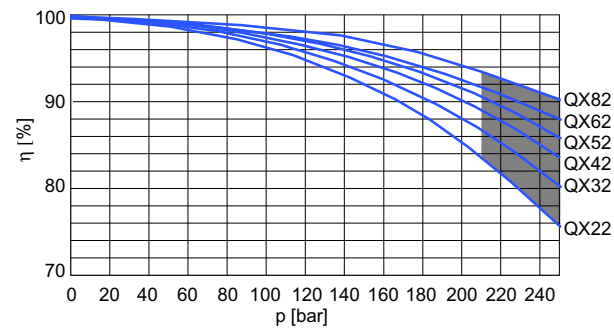

3.2.2.2 Hydromechanical efficiency

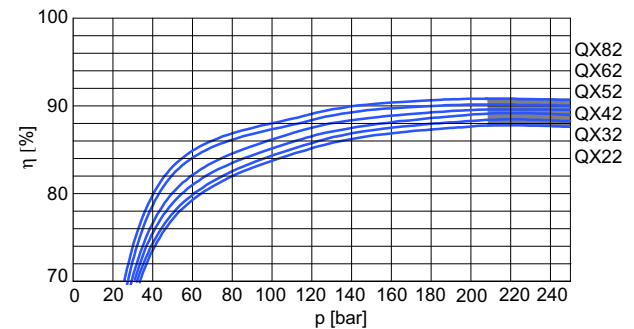

intermittent operating pressure

3.2.3 Pressure range 3

3.2.3.1 Volumetric efficiency

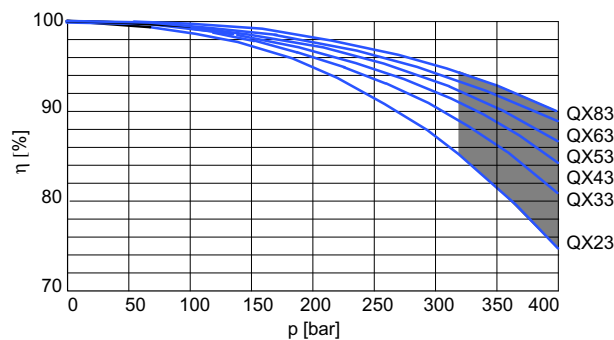

3.2.3.2 Hydromechanical efficiency

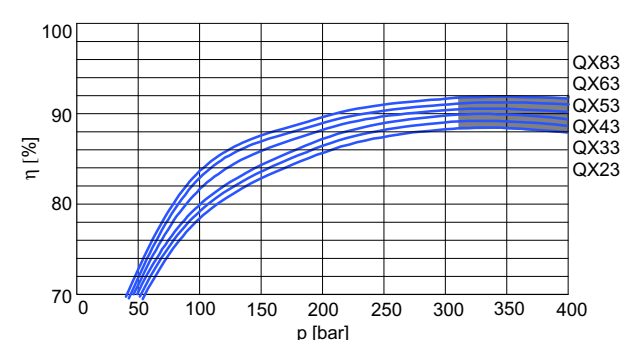

intermittent operating pressure

3.2.4 Pressure range 4

3.2.4.1 Volumetric efficiency

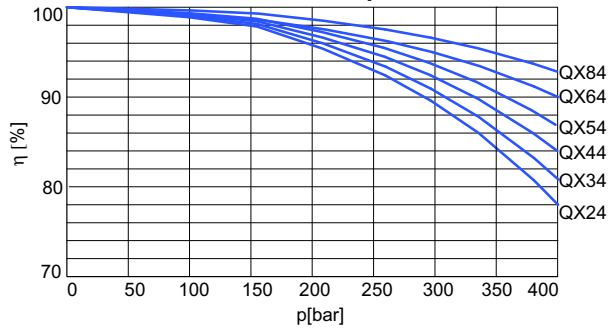

3.2.4.2 Hydromechanical efficiency

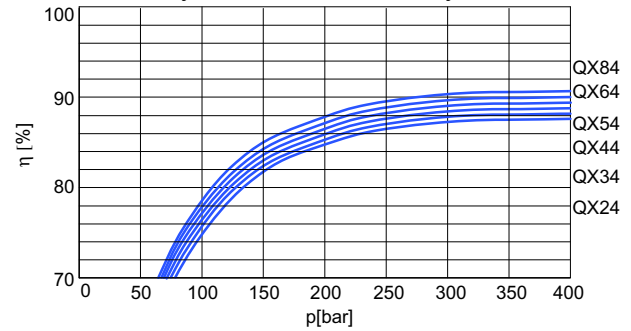

3.3 Operation with variable-speed drives

IMPORTANT: The following main characteristics are to be understood as examples only. They are valid only for the specified pump models and parameters. We would be very happy to advise you on the layout of your drive. QX pumps with variable-speed drive all contain an external drain port.

3.3.1 Typical loading cycle for a QX pump with variable-speed drive

Pump QX53-063 with viscosity 20 mm²/s

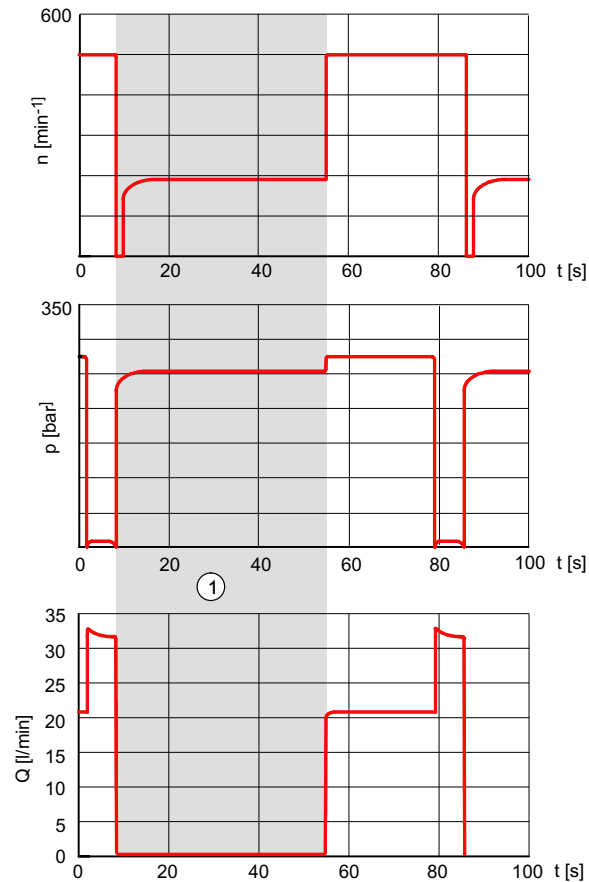

1 | pressure-holding operation
Q = 0 l/min for up to 60 s

3.3.2 Minimum pressure at suction port as a function of speed

Pump QX53-063 measured: with viscosity 42 mm²/s

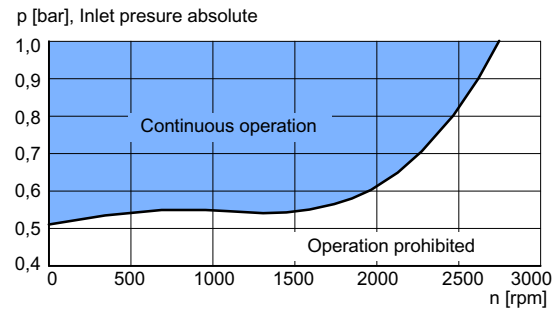

3.3.3 Minimum speed as a function of pressure

Pump QX53-063 measured with viscosity 42 mm²/s

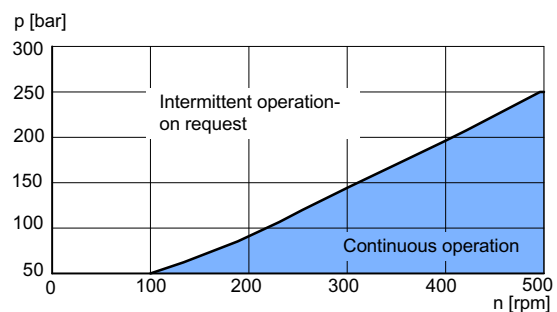

4 Single pumps

4.1 Dimensions frame size 2 - 4

Frame size		2				3				4					
Pressure range		1	2	3	4 ⁵⁾	1	2	3	4	1	2	3	4		
Suction port: to SAE J518 ¹⁾	S	G1" ³⁾ thread				G1 ¼" ³⁾ thread				1½"					
Pressure port: to SAE J518 ¹⁾	P	G ½" ^{3) 4)} thread				G ¾" ^{3) 4)} thread				1"					
External drain port (option 06) pressure range 1-3 optional pressure range 4 standard	①	G ¼"				G ¼"				G ¼"					
Mounting: oval 2-hole flange to ISO 3019/1 (SAE) ISO 3019/2 (metric)	A	118				132				170					
	B (SAE)	-				106				146					
	B (Metr.)	100				109				140					
	C	9				11				14					
	N (SAE)	-				82,55 _{-0,05}				101,6 _{-0,05}					
	N (Metr.)	63 h8				80 h8				100 h8					
	O	8,5				8,5				10,5					
	V	6				6				7					
4-hole flange ISO 3019/2	X (Metr.)	9				9				12					
	Y (Metr.)	85				103				125					
Shaft end: parallel, to ISO/R775 ²⁾	D	20 j6				25 j6				32 j6					
	E	36				42				58					
	F	6				8				10					
	G	22,5				28				35					
	I	45				50				68					
Housing	K	38			37,5	44				52			52,5		
	L	136	118	153	192	164	144	189	232,5	202	176	232	286		
	M	-	55	90	125	-	70	114	159,5	-	87	143	199		
	T1	43				54				53,5	67				
	T2	43				54	60				67	70			
	Z	100				120				125					
	W	80				100				136					
	Weight	kg	6	6	7	8	10	10	13	15	20	18	22	27	

1) Pipe flange dimensions, SAE J518 code 61 / ISO 6162-1.
 - high pressure type up to 420 bar (see section 12.2)
 - low pressure type for up to 16 bar (see section 12.3)

2) For other shaft ends, contact Bucher Hydraulics GmbH.

3) Threaded port to DIN 3852, Part 2.

4) Pressure port to SAE J518 code 61 / ISO 6162-1 can be supplied for pressure ranges 2 + 3.

5) The dimensions are not valid for low-flow capability pumps (3,3 cm³/U and 4,2 cm³/U, see chapter 4.7).

4.2 Dimensions frame size 5 - 8

Frame size		5				6				8			
Pressure range		1	2	3	4	1	2	3	4	1	2	3	4
Suction port: to SAE J518 ¹⁾	S	2"				2½"				3"			
Pressure port: to SAE J518 ¹⁾	P	1¼"				1½"				2"			
External drain port (option 06) pressure range 1-3 optional pressure range 4 standard	①	G ¼"				G ⅜"				G ½"			
Mounting: oval 2-hole flange to ISO 3019/1 (SAE) ISO 3019/2 (metric)	A	212				267				330			
	B (SAE)	181				229				-			
	B (Metr.)	180				224				280			
Mounting: oval 2-hole flange to ISO 3019/1 (SAE) ISO 3019/2 (metric)	C	18				22				26			
	N (SAE)	127 -0,05				152,4 -0,05				-			
	N (Metr.)	125 h8				160 h8				200 h8			
	O	12,5				16,5				20			
	V	7				7				9			
4-hole flange ISO 3019/2	X (Metr.)	14				18				22			
	Y (Metr.)	160				200				250			
Shaft end: parallel, to ISO/R775 ²⁾	D	40 j6				50 j6				63 j6			
	E	82				82				105			
	F	12				14				18			
	G	43				53,5				67			
	I	92				92				117			
Housing	K	60			60,5	74				90			
	L	242	210	280	349	288	248	338	429	361	331	446	446
	M	-	102	172	242	-	119	209	299	-	151	266	266
	T1	89				107	110			137	138		
	T2	89				107	110			137	138		
	Z	156				195	197			250			
	W	165				203				256			
Weight	kg	36	32	41	50	64	57	77	90	130	118	160	200

1) Pipe flange dimensions, SAE J518 code 61 / ISO 6162-1.
 - high pressure type up to 420 bar (see section 12.2)
 - low pressure type for up to 16 bar (see section 12.3)

2) For other shaft ends, contact Bucher Hydraulics GmbH.

4.3 Pressure range 1

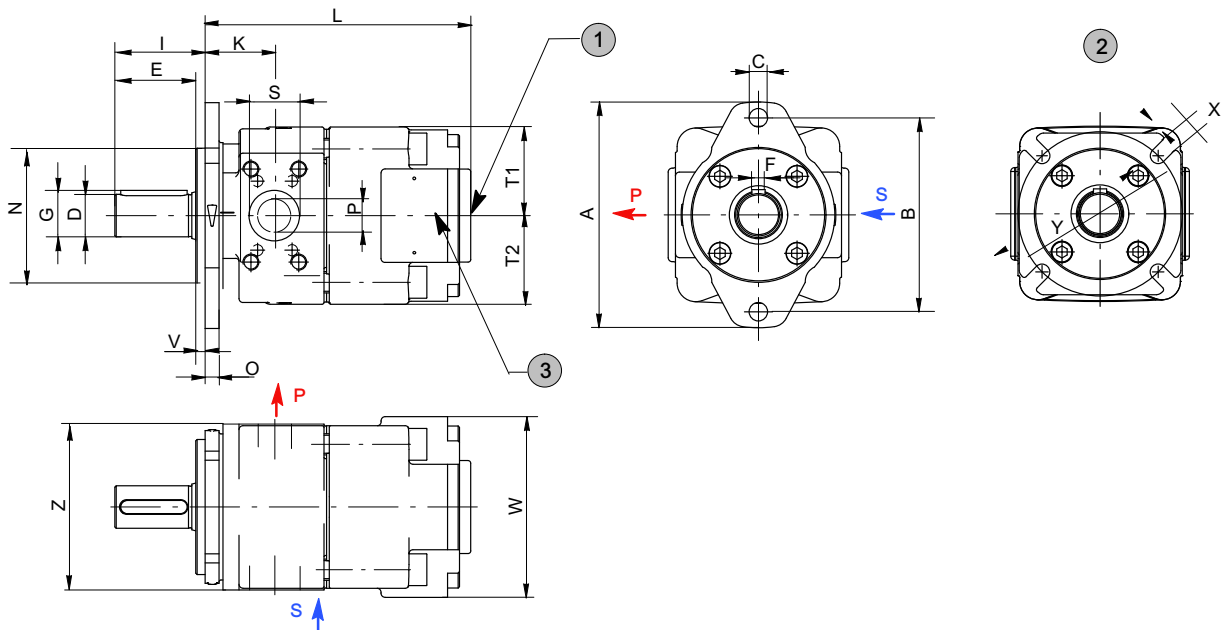

1	option 06 = external drain port
2	option 66 = special model 4-hole flange ISO 3019/2

3	depending on operating conditions, a second suction port may be required on: QX51=SAE 1¼", QX61=SAE 2", QX81=SAE 2½" - see section 2.2.1
---	--

4.4 Pressure range 2

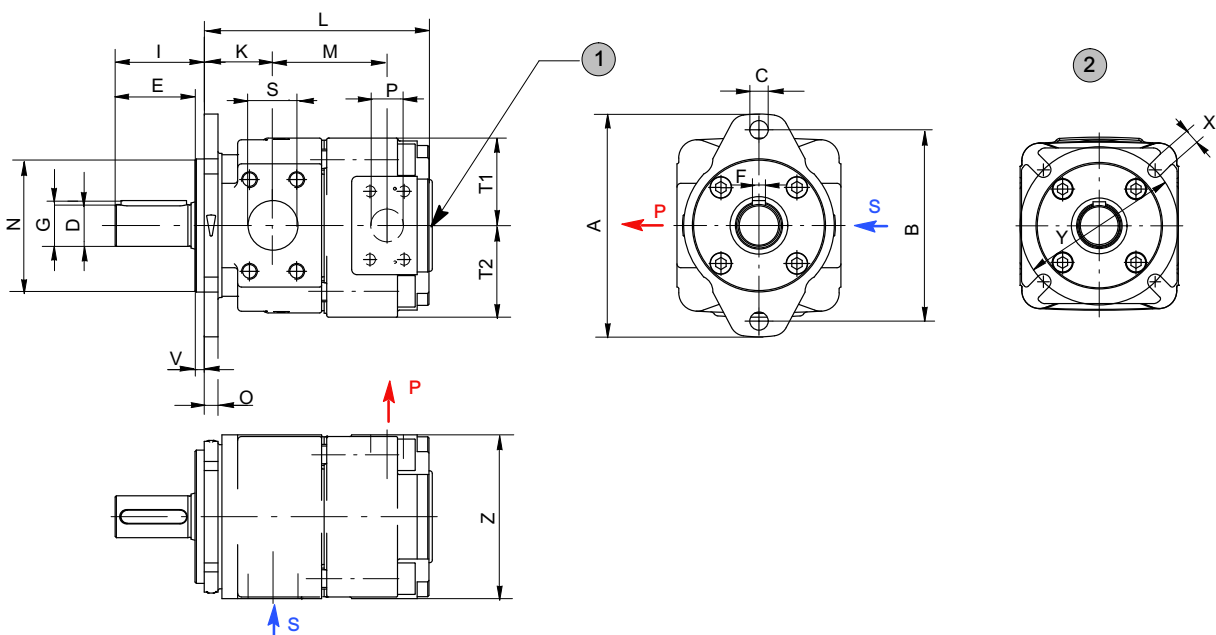

1	option 06 = external drain port
---	---------------------------------

2	option 66 = special model 4-hole flange ISO 3019/2
---	--

4.5 Pressure range 3

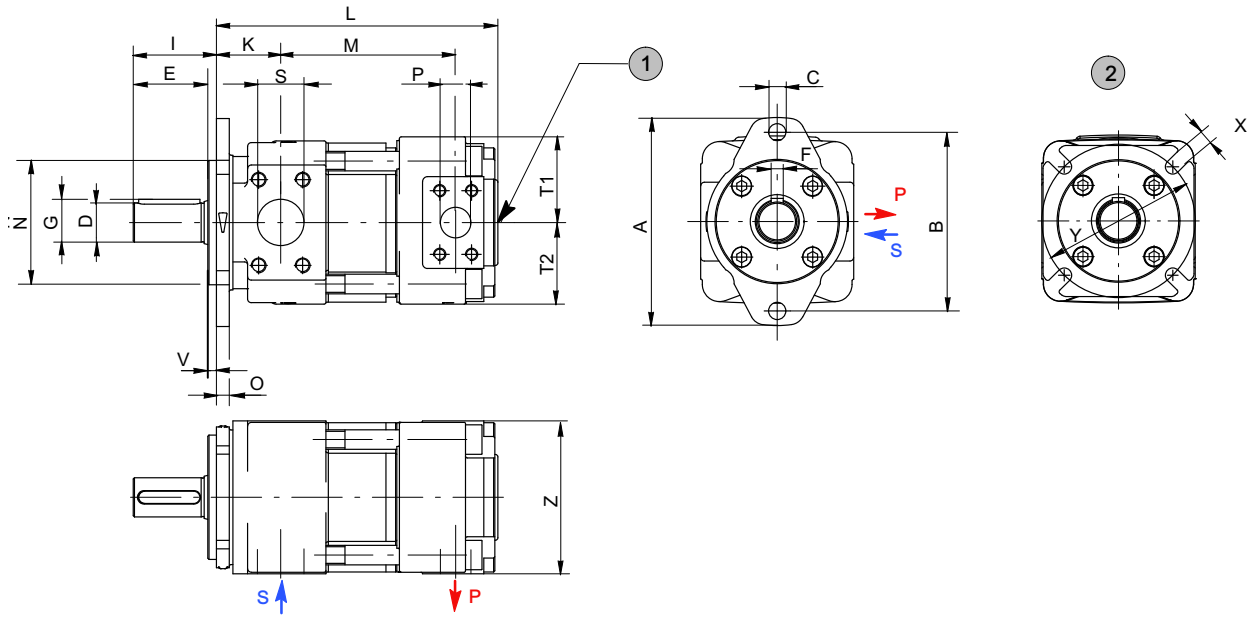

1 external drain port - see special feature 06

2 option 66 = special model 4-hole flange ISO 3019/2

4.6 Pressure range 4

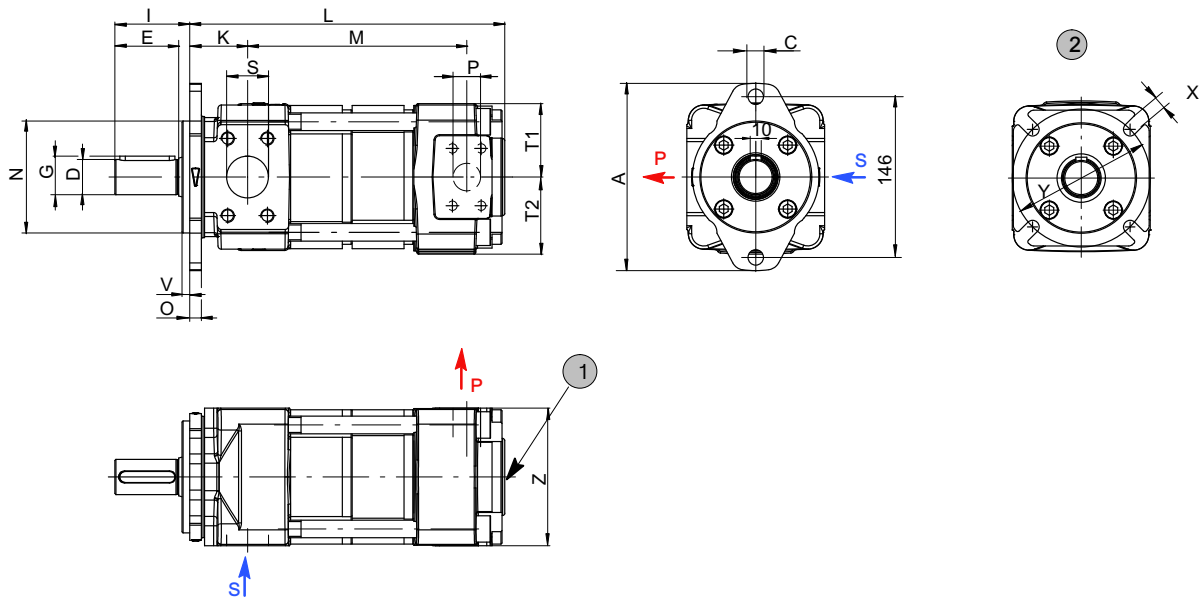

1 external drain port - see special feature 06

2 option 66 = special model 4-hole flange ISO 3019/2

4.7 Pressure range 4 with low-flow capability

QX24 with displacements from 3 and 4 cm³/U.

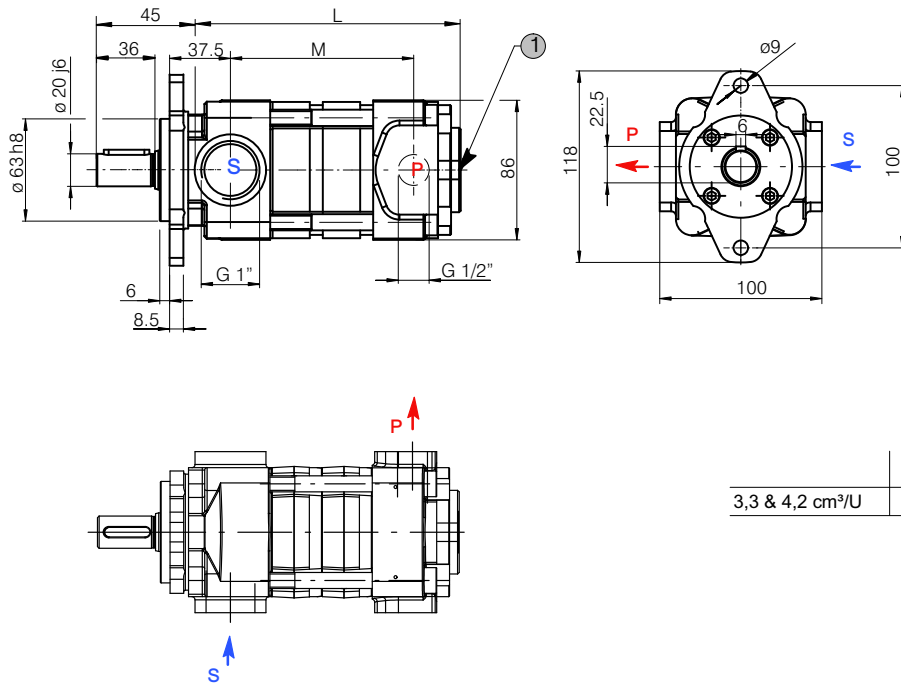

1 external drain port G $\frac{1}{4}$ "

4.8 Ordering code for single pumps

Series	= QX	Q	X	5	3	-	0	4	0	R	*	*
Frame size	= 2 / 3 / 4 / 5 / 6 / 8											
Pressure range	= 1 / 2 / 3 / 4											
Displacement [cm ³ /rev]	= 003 - 500											
Rotation (viewed from shaft end)	right (CW) = R (standard) left (CCW) = L											
Option	see section 4.8.3											

4.8.1 Ordering example:

Required:	single pump
Displacement:	40 cm ³ /rev
Continuous pressure: for use with mineral oil	300 bar
Ordering code:	QX53-040R

4.8.2 Standard configuration

- direction of rotation - right (CW)
- 2-hole mounting flange to ISO 3019/1 (SAE): sizes QX 3-6
- 2-hole mounting flange to ISO 3019/2 (metric): sizes QX 2+8
- Nitrile seals
- cylindrical shaft end to ISO R775
- black priming, flange without priming

4.8.3 Option

- O = without priming
- 06 = external drain port in the pump rear cover
 - QX 2-5 = G ¼"
 - QX 6 = G ⅜"
 - QX 8 = G ½"
- 09 = FKM (Viton) seals and without priming
- 12 = 2-hole mounting flange to ISO 3019/2 (metric): size QX 3-6
- 29 = for HFB and HFC fluids, frame sizes 2-5, without priming
- 66 = 4-hole mounting flange to ISO 3019/2 (metric)
- 83 = second suction port on:
 - QX51 = SAE 1¼"
 - QX61 = SAE 2"
 - QX81 = SAE 2½"
- 86 = for HFB and HFC fluids, frame sizes 6+8, without priming
- 117 = pressure port to SAE J518 code 61 / ISO 6162-1 can be supplied for frame size 2+3 with pressure ranges 2+3

Further options on request.

5 Double pumps

QX double pumps consist of two single pumps mounted on a common drive shaft. Hydraulically, the two pumps operate independently of one another but they share a common suction port in the pump's centre section. The larger pump of the combination is situated at the shaft end (the drive side) and is referred to as pump 1. With equal frame sizes, the pump with the larger displacement is situated at the drive side.

Double pumps can be combined as shown in the following table. If a letter is shown at the intersection point of the two pumps, the letter identifies the page in section 5.2 that contains the relevant dimensional drawing. If there is no letter at the intersection point, then that pump combination is not possible.

IMPORTANT: Double pumps with pressure range 4 on request.

5.1 Selection table

		Pump 2																			Maximum permissible torque [Nm] drive side
		Displacement [cm ³ /rev]																			
		5/6/8			10/12/16			20/25/32			40/50/63			80/100/125			160/200/250			315 400 500	
		Maximum pressure [bar]																			
		250	400	125 160 210	250	400	125 160 210	250	400	125 160 210	250	400	125 160 210	250	400	125 160 210	250	400	125 160 210	Maximum permissible torque [Nm] drive side	
		QX22..	QX23..	QX21..	QX32..	QX33..	QX31..	QX42..	QX43..	QX41..	QX52..	QX53..	QX51..	QX62..	QX63..	QX61..	QX82..	QX83..	QX81..		
Pump 1	5/6/8	250	QX22..	E																65	
		400	QX23..	H	I																
	10/12/16	125/160 210	QX21..	B	C	A															130
		250	QX32..	E	F	D	E														
	20/25/32	400	QX33..	H	I	G	H	I													260
		125/160 210	QX31..	B	C	A	B	C	A												
	40/50/63	250	QX42..	E	F	D	E	F	D	E											520
		400	QX43..	H	I	G	H	I	G	H	I										
	80/100/125	125/160 210	QX41..	B	C	A	B	C	A	B	C	A									1050
		250	QX52..	E	F	D	E	F	D	E	F	D	E								
	160/200/250	400	QX53..	H	I	G	H	I	G	H	I	G	H	I							2100
		125/160 210	QX51..	B	C	A	B	C	A	B	C	A	B	C	A						
	315 400 500	80/100/125	250	QX62..				E	F	D	E	F	D	E	F	D	E				2100
			400	QX63..				H	I	G	H	I	G	H	I	G	H	I			
		160/200/250	125/160 210	QX61..				B	C	A	B	C	A	B	C	A	B	C	A		
	250		QX82..							E	F	D	E	F	D	E	F	D	E		
	315 400 500	160/200/250	400	QX83..						H	I	G	H	I	G	H	I	G	H	I	2100
			125/160 210	QX81..						B	C	A	B	C	A	B	C	A	B	C	

5.2 Dimensions

A Double pumps QX.1/1

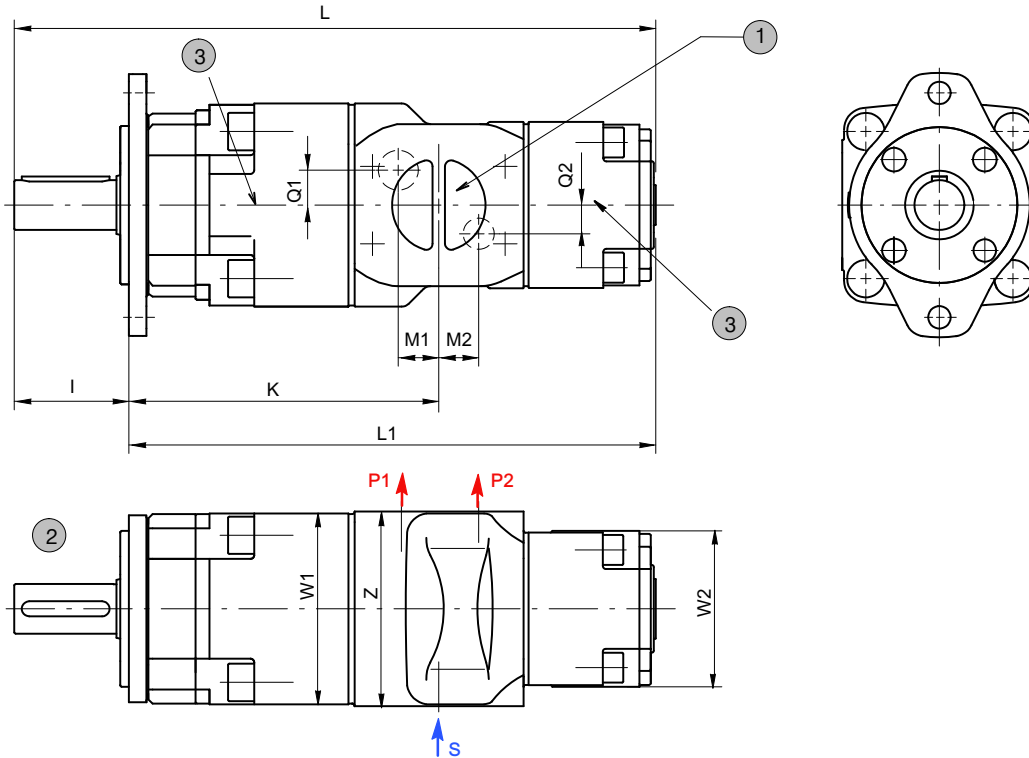

1	S = common suction port
2	shaft and mounting dimensions see section 4

3	depending on operating conditions, a second suction port may be required - see section 2.2.1 QX51=SAE 1¼", QX61=SAE 2", QX81=SAE 2½"
---	--

Type	L	L1	K	M1	M2	Q1	Q2	I	Z	W1	W2	S	P1	P2
QX21/21	296	251	141	18	18			45	100	80	80	G 1¼" 1)	G ½" 1) 2)	
QX31/21	343	293		26	30			50	120	100	80	G 1½" 1)	G ¾" 1) 2)	G ½" 1) 2)
QX31/31	358	308	171	26	26	-	-			100	100			G ¾" 1) 2)
QX41/21	396	328		19	35	15		68	125	136	80	SAE 2"	SAE 1"	G ½" 1) 2)
QX41/31	411	343	201	33	15	15	136			100	G ¾" 1) 2)			
QX41/41	449	381	208	26	26	23	23			136	136			SAE 1"
QX51/21	468	376		23	43	15		92	156	165	80	SAE 2½"	SAE 1¼"	G ½" 1) 2)
QX51/31	483	391	241	39	15	15	165			100	G ¾" 1) 2)			
QX51/41	521	429	249	32	28	23	165			136	SAE 1"			
QX51/51	547	455		30	30	28		92	195	165	165	SAE 3"	SAE 1¼"	SAE 1¼"
QX61/31	541	449	287	24	47	17	14			203	100			G ¾" 1) 2)
QX61/41	564	472	27	39	26	27	203			136	SAE 1"			
QX61/51	601	509		32	40	35		92	250	203	165	SAE 1½"	SAE 1½"	SAE 1¼"
QX61/61	628	536	292	32	35	35	203			203	SAE 1½"			
QX81/41	679	562		35	51	25	25			250	136			SAE 1"
QX81/51	705	588		47	30	30		117	250	250	165	SAE 3½"	SAE 2"	SAE 1¼"
QX81/61	732	615	359	45	35	35	250			203	SAE 1½"			
QX81/81	774	657	38	38	40	40	256			256	SAE 4"			SAE 2"

1) threaded port to DIN 3852, Part 2

2) pressure port to SAE J518 code 61 / ISO 6162-1 can be supplied for pressure ranges 2+3

B Double pumps QX.1/2

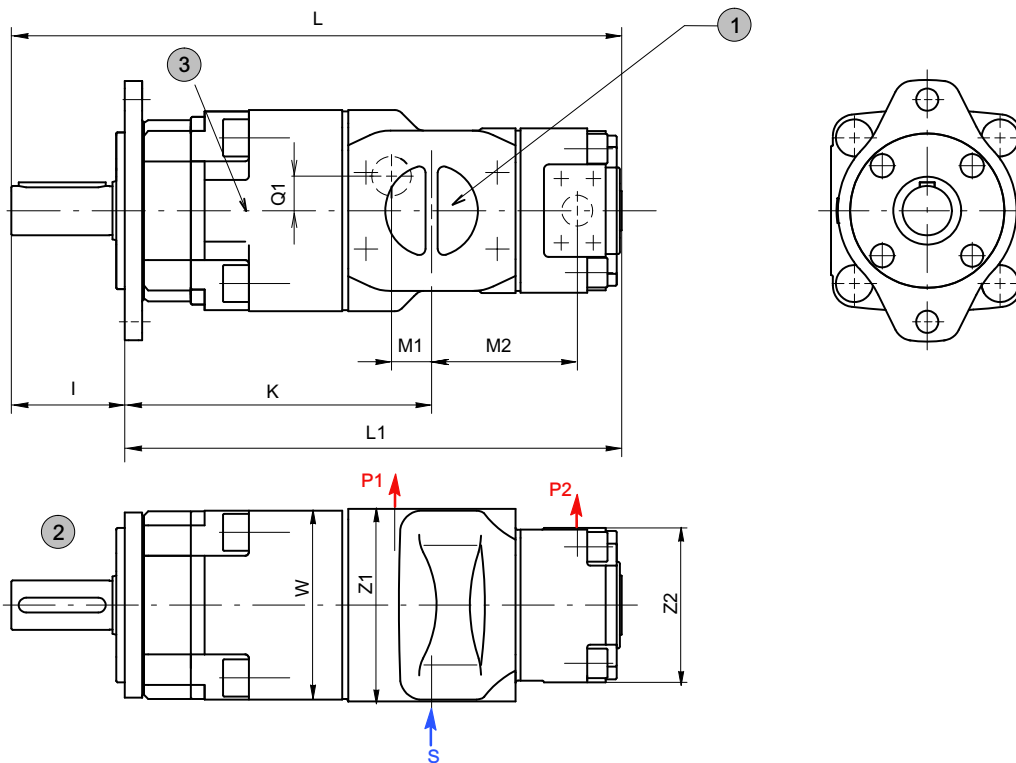

1	S = common suction port
2	shaft and mounting dimensions see section 4

3	depending on operating conditions, a second suction port may be required - see section 2.2.1: QX51=SAE 1 1/4", QX61=SAE 2", QX81=SAE 2 1/2"
---	---

Type	L	L1	K	M1	M2	Q1	I	Z1	Z2	W	S	P1	P2		
QX21/22	278	233	141	18	67	-	45	100	100	80	G 1 1/4" ¹⁾	G 1/2" ^{1) 2)}	G 1/2" ^{1) 2)}		
QX31/22	325	275	171	26	79		50	120		100	G 1 1/2" ¹⁾	G 3/4" ^{1) 2)}			
QX31/32	338	288		87	15	68	125	136	100	SAE 2"	SAE 1"	G 3/4" ^{1) 2)}			
QX41/22	378	310	201	19								84	120	125	SAE 1"
QX41/32	391	323	208	26	92	23	92	156	165	SAE 2 1/2"	SAE 1 1/4"	G 1/2" ^{1) 2)}			
QX41/42	423	355			111							15	100	120	125
QX51/22	450	358	241	23	92	15	92	156	203	SAE 3"	SAE 1 1/2"	G 1/2" ^{1) 2)}			
QX51/32	463	371			100							28	120	125	156
QX51/42	495	403	249	30	118	17	92	195	203	SAE 3"	SAE 1 1/2"	SAE 1"			
QX51/52	515	423			127							26	125	156	197
QX61/32	521	429	287	24	112	17	92	195	203	SAE 3 1/2"	SAE 2"	G 3/4" ^{1) 2)}			
QX61/42	538	446		27	123							26	125	156	197
QX61/52	569	477	292	32	137	35	117	250	256	SAE 3 1/2"	SAE 2"	SAE 1 1/4"			
QX61/62	588	496			149							40	156	197	250
QX81/42	653	536	359	35	141	25	117	250	256	SAE 4"	SAE 2"	SAE 1"			
QX81/52	673	556			150							40	156	197	250
QX81/62	692	575		38	162	40						197	250	250	SAE 1 1/2"
QX81/82	724	607			179							40	250	250	250

1) threaded port to DIN 3852, Part 2

2) pressure port to SAE J518 code 61 / ISO 6162-1 can be supplied for pressure ranges 2+3

C Double pumps QX.1/3

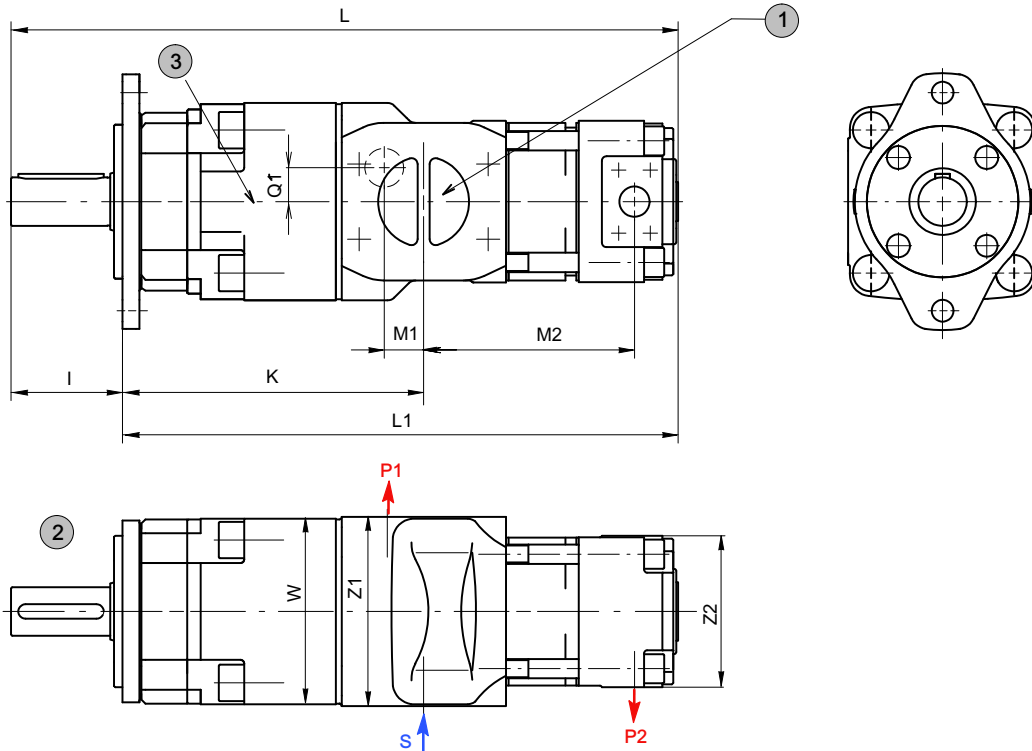

1	S = common suction port
2	shaft and mounting dimensions see section 4

3	depending on operating conditions, a second suction port may be required - see section 2.2.1: QX51=SAE 1 1/4", QX61=SAE 2", QX81=SAE 2 1/2"
---	---

Type	L	L1	K	M1	M2	Q1	I	Z1	Z2	W	S	P1	P2	
QX21/23	313	268	141	18	102	-	45	100	100	80	G 1 1/4" ¹⁾	G 1/2" ^{1) 2)}	G 1/2" ^{1) 2)}	
QX31/23	360	310	171	26	114		50	120	100	100	G 1 1/2" ¹⁾	G 3/4" ^{1) 2)}		
QX31/33	383	333			132		120	100	100	100	G 1 1/2" ¹⁾	G 3/4" ^{1) 2)}		
QX41/23	413	345	201	19	119	15	68	125	100	136	SAE 2"	SAE 1"	G 1/2" ^{1) 2)}	
QX41/33	436	368			137	120			G 3/4" ^{1) 2)}					
QX41/43	479	411			167	125			SAE 1"					
QX51/23	485	393	241	23	127	15	92	156	100	165	SAE 2 1/2"	SAE 1 1/4"	G 1/2" ^{1) 2)}	
QX51/33	508	416			145				120				G 3/4" ^{1) 2)}	
QX51/43	551	459	249	30	174				28				125	125
QX51/53	585	493			197	156	SAE 1 1/4"							
QX61/33	566	474	287	24	157	17	92	195	120	203	SAE 3"	SAE 1 1/2"	G 3/4" ^{1) 2)}	
QX61/43	594	502			27				179				26	125
QX61/53	637	545	292	32	207				35				156	197
QX61/63	678	586			239	197	SAE 1 1/2"							
QX81/43	709	592	359	35	197	25	117	250	125	256	SAE 3 1/2"	SAE 2"	SAE 1"	
QX81/53	743	626			220				156				SAE 1 1/4"	
QX81/63	782	665		38	252	40			197				197	SAE 1 1/2"
QX81/83	839	722			294				250				SAE 2"	

1) threaded port to DIN 3852, Part 2

2) pressure port to SAE J518 code 61 / ISO 6162-1 can be supplied for pressure ranges 2+3

D Double pumps QX.2/1

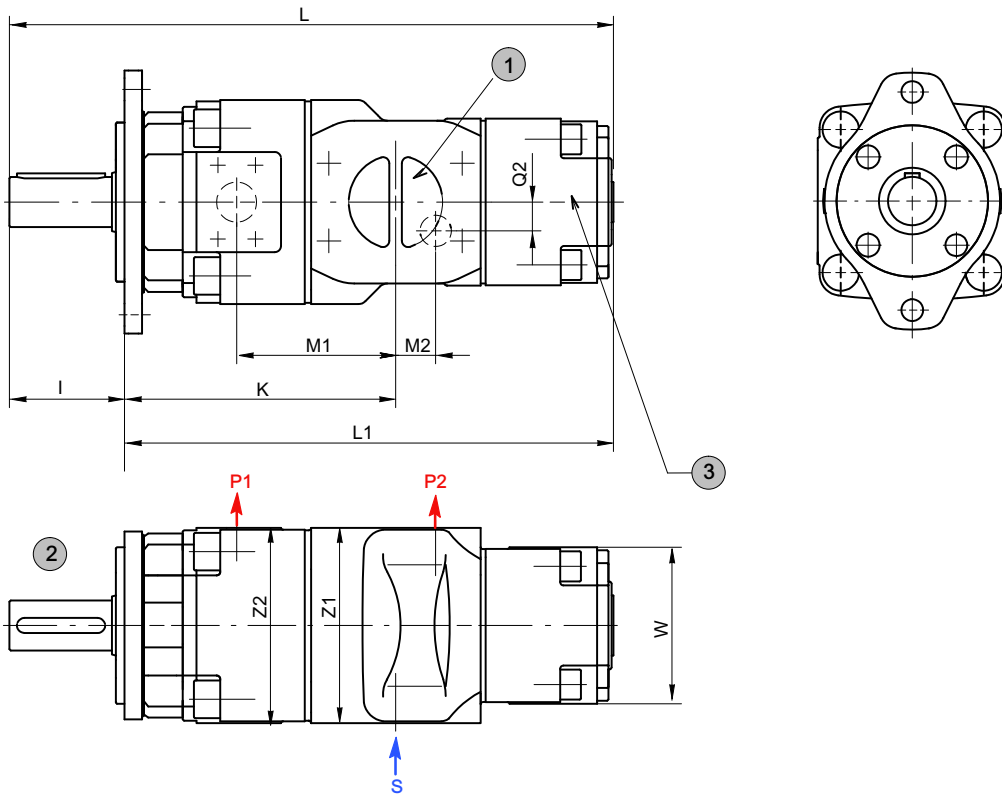

- | | |
|---|---|
| 1 | S = common suction port |
| 2 | shaft and mounting dimensions see section 4 |

- | | |
|---|---|
| 3 | depending on operating conditions, a second suction port may be required - see section 2.2.1:
QX51=SAE 1 1/4", QX61=SAE 2" |
|---|---|

Type	L	L1	K	M1	M2	Q2	I	Z1	Z2	W	S	P1	P2
QX32/21	323	273	151	87	30	-	50	120	120	80	G 1 1/2" 1)	G 3/4" 1) 2)	G 1/2" 1) 2)
QX42/21	370	302	175	103	35	-	68	125	125	100	SAE 2"	SAE 1"	G 3/4" 1) 2)
QX42/31	385	317			33	15							
QX52/21	436	344	209	120	43	-	92	156	156	80	SAE 2 1/2"	SAE 1 1/4"	G 1/2" 1) 2)
QX52/31	451	359			39	15							G 3/4" 1) 2)
QX52/41	489	397	217	127	32	23	92	195	197	136	SAE 3"	SAE 1 1/2"	SAE 1"
QX62/31	501	409	247	144	47	14							G 3/4" 1) 2)
QX62/41	524	432			39	27	136	SAE 1 1/4"	SAE 1"				
QX62/51	561	469	252	149	40	28	117	250	250	165	SAE 3 1/2"	SAE 2"	SAE 1 1/4"
QX82/41	629	512	309	179	51	25							136
QX82/51	655	538			47	30	165	SAE 2"	SAE 1 1/4"				
QX82/61	682	565			45	35	203	SAE 4"	SAE 1 1/2"				

1) threaded port to DIN 3852, Part 2

2) pressure port to SAE J518 code 61 / ISO 6162-1 can be supplied for pressure ranges 2+3

E Double pumps QX.2/2

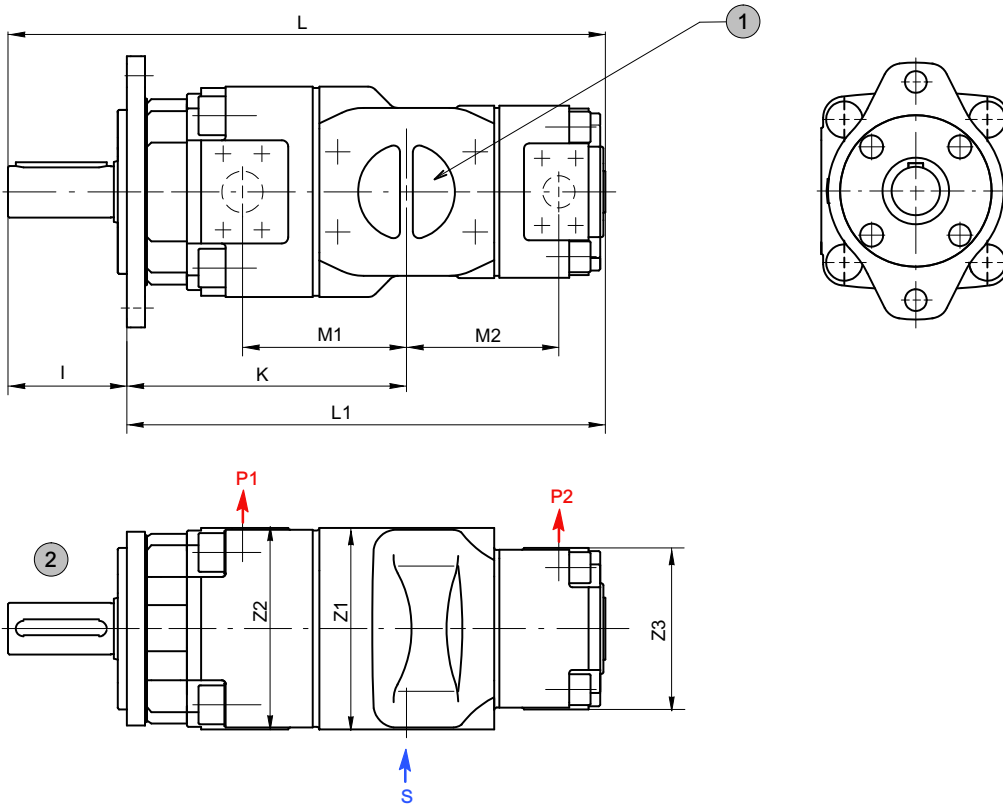

1 S = common suction port

2 shaft and mounting dimensions - see section 4

Type	L	L1	K	M1	M2	I	Z1	Z2	Z3	S	P1	P2
QX22/22	260	215	123	67	67	45	100		100	G 1¼" ¹⁾	G ½" ^{1) 2)}	G ½" ^{1) 2)}
QX32/22	305	255	151	87	79	50	120		120	G 1½" ¹⁾	G ¾" ^{1) 2)}	G ¾" ^{1) 2)}
QX32/32	318	268			87							
QX42/22	352	284	175	103	84	68	125		100	SAE 2"	SAE 1"	G ½" ^{1) 2)}
QX42/32	365	297			92			G ¾" ^{1) 2)}				
QX42/42	397	329	182	111	111			125			SAE 1"	
QX52/22	418	326	209	120	92	92	156		100	SAE 2½"	SAE 1¼"	G ½" ^{1) 2)}
QX52/32	431	339			100			120	G ¾" ^{1) 2)}			
QX52/42	463	371	217	127	118			125		SAE 3"	SAE 1¼"	SAE 1"
QX52/52	483	391			127	156	SAE 1¼"					
QX62/32	481	389	247	144	112	92	195	197	120	SAE 3½"	SAE 1½"	G ¾" ^{1) 2)}
QX62/42	498	406			123				125			SAE 1"
QX62/52	529	437	252	149	137			156		SAE 3½"	SAE 1½"	SAE 1¼"
QX62/62	548	456			149	197	SAE 1½"					
QX82/42	603	486	309	179	141	117	250		125	SAE 3½"	SAE 2"	SAE 1"
QX82/52	623	506			150			156	SAE 1¼"			
QX82/62	642	525			162			197	SAE 1½"			
QX82/82	674	557			179			250	SAE 2"			

1) threaded port to DIN 3852, Part 2

2) pressure port to SAE J518 code 61 / ISO 6162-1 can be supplied for pressure ranges 2+3

F Double pumps QX.2/3

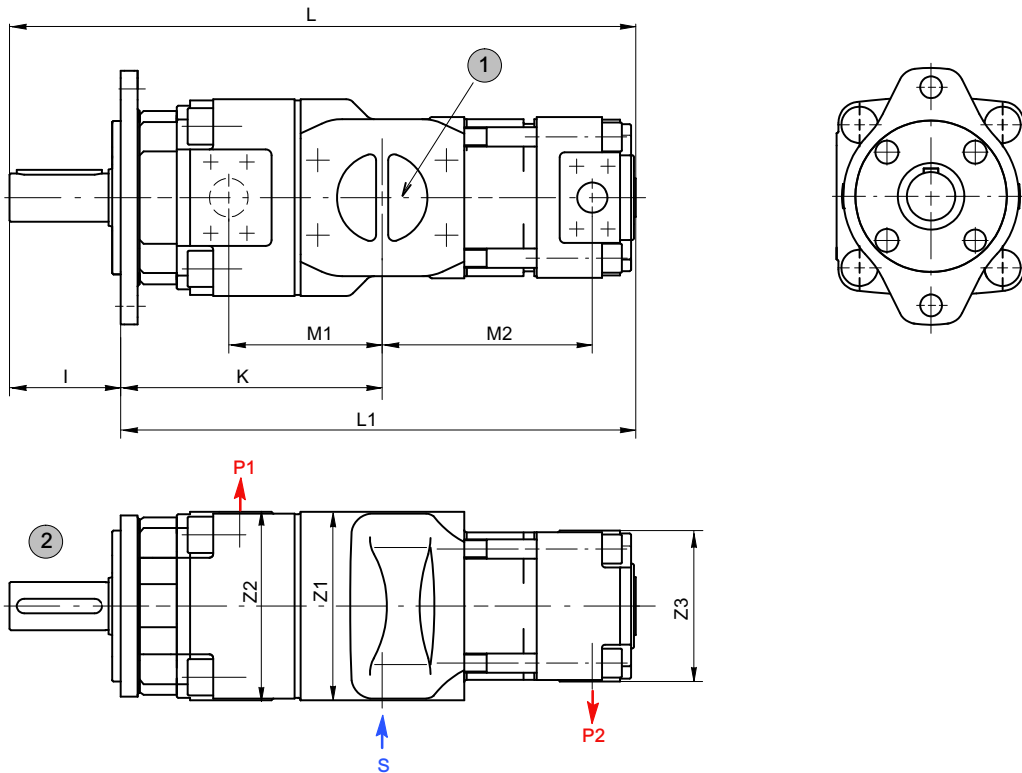

1 S = common suction port

2 shaft and mounting dimensions - see section 4

Type	L	L1	K	M1	M2	I	Z1	Z2	Z3	S	P1	P2
QX32/23	340	290	151	87	114	50	120		100	G 1½" ¹⁾	G ¾" ^{1) 2)}	G ½" ^{1) 2)}
QX42/23	387	319	175	103	119	68	125		120	SAE 2"	SAE 1"	G ¾" ^{1) 2)}
QX42/33	410	342			137							
QX52/23	453	361	209	120	127	92	156		100	SAE 2½"	SAE 1¼"	G ½" ^{1) 2)}
QX52/33	476	384			145			G ¾" ^{1) 2)}				
QX52/43	519	427	217	127	174			125	120	SAE 3"	SAE 1½"	SAE 1"
QX62/33	526	434	247	144	157	92	195	197				G ¾" ^{1) 2)}
QX62/43	554	462			179				125	SAE 1"		
QX62/53	599	507	252	149	207			156	125	SAE 3½"	SAE 1½"	SAE 1¼"
QX82/43	659	542			197	117	250	125				SAE 1"
QX82/53	693	576	309	179	220			156	197	197	SAE 2"	SAE 2"
QX82/63	732	615			252	156	SAE 1½"					

1) threaded port to DIN 3852, Part 2

2) pressure port to SAE J518 code 61 / ISO 6162-1 can be supplied for pressure ranges 2+3

G Double pumps QX.3/1

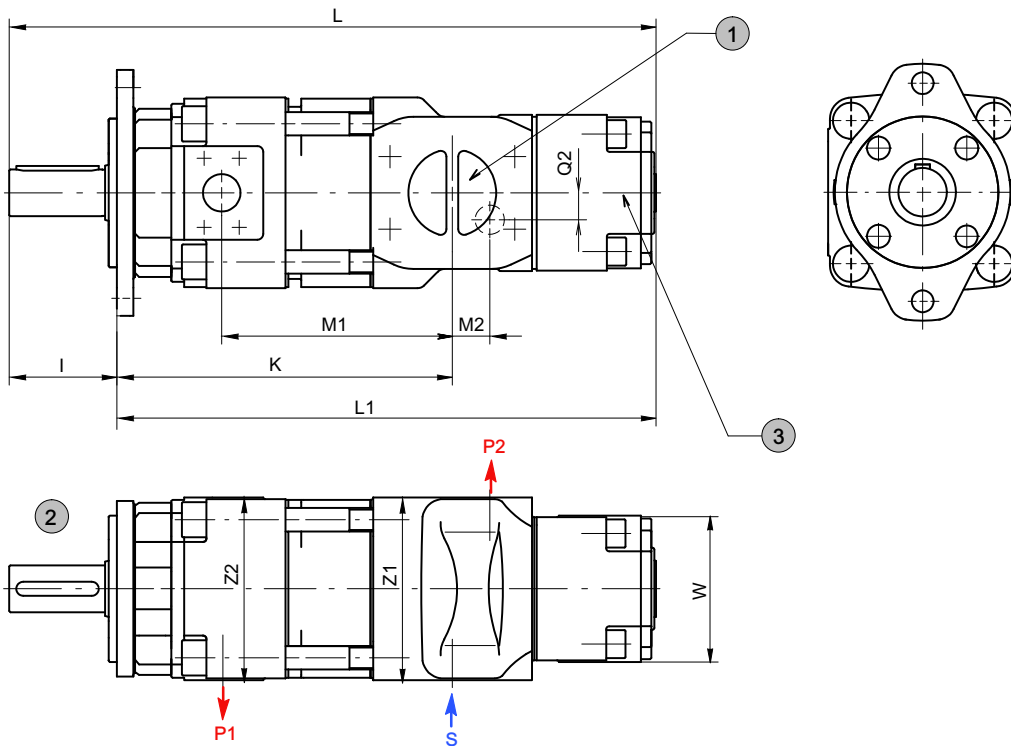

1	S = common suction port
2	shaft and mounting dimensions - see section 4

3	depending on operating conditions, a second suction port may be required - see section 2.2.1 QX61=SAE 2"
---	--

Type	L	L1	K	M1	M2	Q2	I	Z1	Z2	W	S	P1	P2	
QX33/21	368	318	196	132	30	-	50	120	120	80	G 1½" ¹⁾	G ¾" ^{1) 2)}	G ½" ^{1) 2)}	
QX43/21	426	358	231	159	35	-	68	125	125		SAE 2"	SAE 1"	G ¾" ^{1) 2)}	
QX43/31	441	373			33	15								
QX53/21	506	414	279	190	43	-	92	156	156	80	SAE 2½"	SAE 1¼"	G ½" ^{1) 2)}	
QX53/31	521	429			39	15							G ¾" ^{1) 2)}	
QX53/41	559	467			287	197				32			23	136
QX63/31	591	499	337	234	47	14	92	195	197	100	SAE 3"	SAE 1½"	G ¾" ^{1) 2)}	
QX63/41	614	522			39	27							SAE 1"	
QX63/51	651	559	342	239	40	28	117	250	250	165	SAE 2"	SAE 1¼"	SAE 1½"	
QX83/41	744	627	424	294	51	25							136	SAE 3½"
QX83/51	770	653			47	30				165			SAE 2"	SAE 1¼"
QX83/61	797	680			45	35	203	SAE 4"	SAE 1½"					

1) threaded port to DIN 3852, Part 2

2) pressure port to SAE J518 code 61 / ISO 6162-1 can be supplied for pressure ranges 2+3

H Double pumps QX.3/2

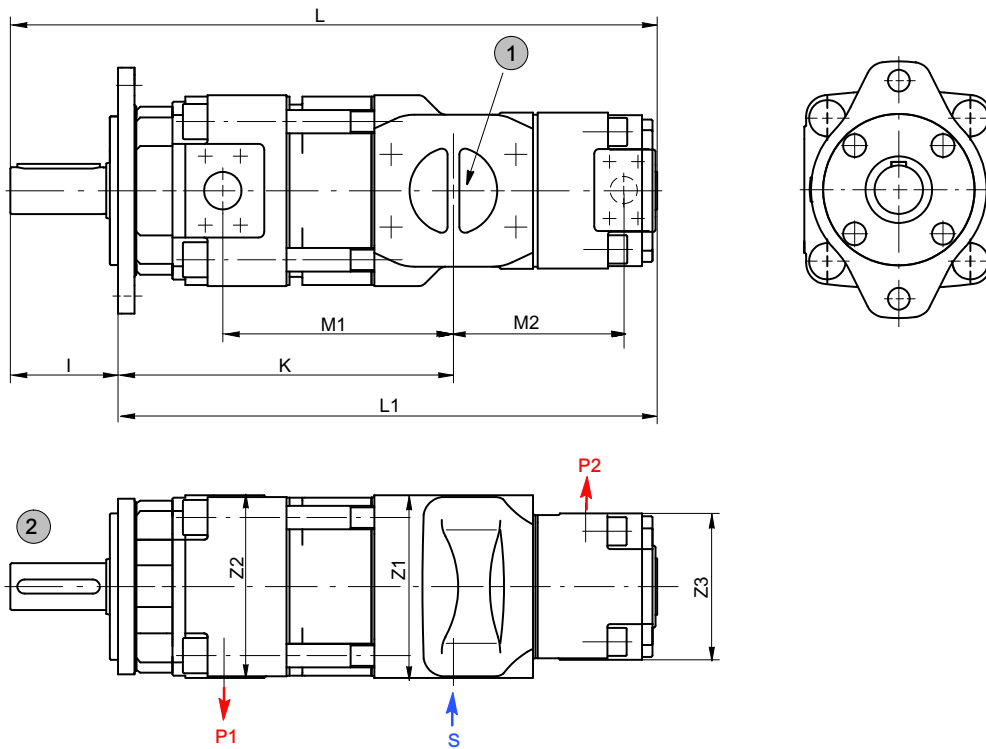

1 S = common suction port

2 shaft and mounting dimensions - see section 4

Type	L	L1	K	M1	M2	I	Z1	Z2	Z3	S	P1	P2
QX23/22	295	250	158	102	67	45	100		100	G 1 1/4" 1)	G 1/2" 1) 2)	G 1/2" 1) 2)
QX33/22	350	300	196	132	79	50	120		100	G 1 1/2" 1)	G 3/4" 1) 2)	G 3/4" 1) 2)
QX33/32	363	313		87	120							
QX43/22	408	340	231	159	84	68	125		100	SAE 2"	SAE 1"	G 1/2" 1) 2)
QX43/32	421	353			92			120	G 3/4" 1) 2)			
QX43/42	453	385	238	167	111			125	125			SAE 1"
QX53/22	488	396	279	190	92	92	156		100	SAE 2 1/2"	SAE 1 1/4"	G 1/2" 1) 2)
QX53/32	500	408			100			120	G 3/4" 1) 2)			
QX53/42	533	441	287	197	118			125	125	SAE 3"	SAE 1 1/4"	SAE 1"
QX53/52	553	461			127	156	SAE 1 1/4"					
QX63/32	571	479	337	234	112	92	195	197	120	SAE 3 1/2"	SAE 1 1/2"	G 3/4" 1)
QX63/42	588	496			123				125			SAE 1"
QX63/52	619	527	342	239	137			156	156	SAE 3 1/2"	SAE 1 1/2"	SAE 1 1/4"
QX63/62	638	546			149	197	SAE 1 1/2"					
QX83/42	718	601	424	294	141	117	250		125	SAE 4"	SAE 2"	SAE 1"
QX83/52	738	621			150			156	SAE 1 1/4"			
QX83/62	757	640			162			197	SAE 1 1/2"			
QX83/82	789	672			179			250	SAE 2"			

1) threaded port to DIN 3852, Part 2

2) pressure port to SAE J518 code 61 / ISO 6162-1 can be supplied for pressure ranges 2+3

I Double pumps QX.3/3

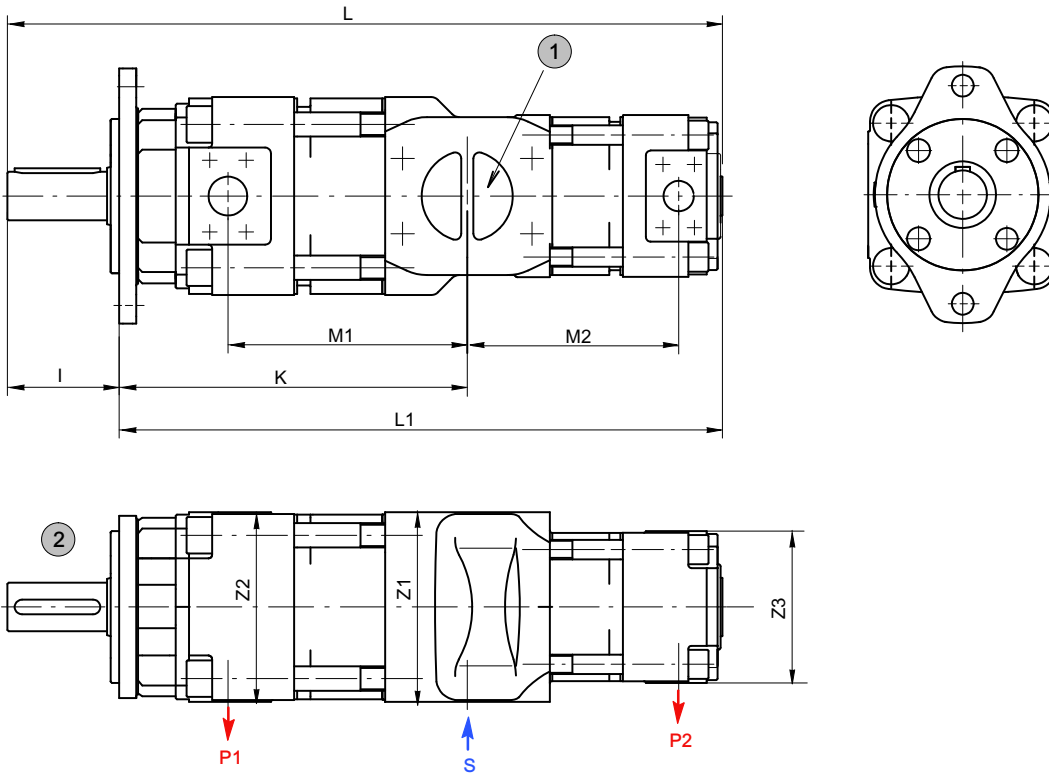

1 S = common suction port

2 shaft and mounting dimensions - see section 4

Type	L	L1	K	M1	M2	I	Z1	Z2	Z3	S	P1	P2
QX23/23	330	285	158	102	102	45	100		100	G 1¼" 1) 2)	G ½" 1) 2)	G ½" 1) 2)
QX33/23	385	335	196	132	114	50	120		120	G 1½" 1) 2)	G ¾" 1) 2)	G ¾" 1) 2)
QX33/33	408	358			132							
QX43/23	442	374	231	159	119	68	125		100	SAE 2"	SAE 1"	G ½" 1) 2)
QX43/33	466	398			137			G ¾" 1)				
QX43/43	509	441	238	167	167				120			SAE 1"
QX53/23	523	431	279	190	127	92	156		100	SAE 2½"	SAE 1¼"	G ½" 1) 2)
QX53/33	546	454			145			G ¾" 1) 2)				
QX53/43	589	497	287	197	174				125	SAE 3"	SAE 1¼"	SAE 1"
QX53/53	623	531			197	SAE 1¼"						
QX63/33	616	524	337	234	157	92	195	197	120	SAE 3½"	SAE 1½"	G ¾" 1) 2)
QX63/43	644	552			179							SAE 1"
QX63/53	689	597	342	239	207				156	SAE 3½"	SAE 1½"	SAE 1¼"
QX63/63	728	636			239	SAE 1½"						
QX83/43	774	657	424	294	197	117	250		125	SAE 4"	SAE 2"	SAE 1"
QX83/53	808	691			220			SAE 1¼"				
QX83/63	847	730			252			SAE 1½"				
QX83/83	904	787			294			SAE 2"				

1) threaded port to DIN 3852, Part 2

2) pressure port to SAE J518 code 61 / ISO 6162-1 can be supplied for pressure ranges 2+3

5.3 Ordering code for double pumps

		Q X 6 3 - 0 8 0 / 3 1 - 0 2 0 R * *
Series	= QX	
Frame size	= 2 / 3 / 4 / 5 / 6 / 8	
Pressure range	= 1 / 2 / 3 / 4 ¹⁾	
Displacement [cm ³ /rev]	= 005 - 500	
	Frame size	= 2 / 3 / 4 / 5 / 6 / 8
	Pressure range	= 1 / 2 / 3 / 4 ¹⁾
	Displacement [cm ³ /rev]	= 005 - 500
Rotation (viewed from shaft end)	right (CW) = R (standard) left (CCW) = L	
Option	see section 5.3.3	

1) Pressure range 4 on request.

5.3.1 Ordering example:

Required: double pump

Pump 1

Displacement: 80 cm³/rev
Continuous pressure: 300 bar
Type: 63-080

Pump 2

Displacement: 20 cm³/rev
Continuous pressure: 160 bar
Type: 31-020

for use with mineral oil

Ordering code: QX63-080/31-020R

5.3.2 Standard configuration

- direction of rotation - right (CW)
- 2-hole mounting flange to ISO 3019/1 (SAE): sizes QX 3-6
- 2-hole mounting flange to ISO 3019/2 (metr.): sizes QX 2+8
- Nitrile seals
- parallel shaft end to ISO/R775
- black priming, flange without priming

5.3.3 Options

- O = without priming
- 06 = external drain port in the pump rear cover
 - QX 2-5 = G 1/4"
 - QX 6 = G 3/8"
 - QX 8 = G 1/2"
- 09 = FKM (Viton) seals and without priming
- 12 = 2-hole mounting flange to ISO 3019/2 (metric): size QX 3-6
- 29 = for HFB and HFC fluids, frame sizes 2-5, without priming
- 66 = 4-hole mounting flange to ISO 3019/2 (metric)
- 83 = second suction port on:
 - QX51=SAE 1 1/4", QX61=SAE 2", QX81=SAE 2 1/2"
- 86 = for HFB and HFC fluids, frame sizes 6+8, without priming
- 117 = pressure port to SAE J518 code 61 / ISO 6162-1 can be supplied for frame size 2+3 with pressure ranges 2+3

Further options on request.

6 Triple pumps

The following table shows the triple-pump combinations that can be supplied (other triple-pumps on request). The individual pumps 1, 2 and 3 must be specified in accordance with the main characteristics shown in section 2.

The largest pump of the combination is situated at the shaft end and is referred to as Pump 1. For equal frame sizes, the pump with the larger displacement is situated at the drive side. Pumps 2 and 3 have a common suction port.

IMPORTANT: Triple pumps with pressure range 4 on request.

6.1 Selection table

Frame size of pump 1

QX2.	QX3.	QX4.	QX5.	QX5.	QX6.	QX8.
QX21/21/21	QX31/21/21	QX41/21/21	QX51/22/23	QX52/52/31	QX61/31/33	QX81/42/23
QX21/21/22	QX31/21/22	QX41/21/23	QX51/23/23	QX52/52/42	QX61/41/21	QX82/42/43
QX21/21/23	QX31/21/23	QX41/22/22	QX52/23/23	QX52/52/43	QX61/41/42	QX82/51/53
QX21/22/22	QX31/22/22	QX41/23/23	QX53/22/22	QX52/52/52	QX61/42/23	QX83/51/53
QX21/22/23	QX31/22/23	QX42/22/22	QX51/31/33	QX52/52/53	QX61/42/43	QX81/61/61
QX21/23/23	QX31/23/22	QX43/22/22	QX51/33/33	QX52/53/31	QX61/43/43	QX81/62/63
QX22/22/22	QX31/23/23	QX43/23/22	QX51/41/23	QX52/53/53	QX62/41/22	QX81/63/33
QX22/22/23	QX32/22/22	QX43/23/23	QX51/41/42	QX53/53/23	QX62/42/42	QX82/61/61
QX23/23/23	QX32/22/23	QX41/31/33	QX51/41/43	QX53/53/33	QX62/43/43	QX82/62/62
	QX32/23/23	QX41/33/22	QX51/42/22		QX63/43/22	QX82/63/31
	QX33/21/22	QX41/33/33	QX51/42/43		QX61/52/53	QX83/61/61
	QX33/21/23	QX42/31/32	QX51/43/21		QX61/53/23	QX83/63/43
	QX33/23/23	QX42/32/32	QX51/43/22		QX61/53/31	QX83/63/61
	QX31/31/21	QX42/33/32	QX51/43/23		QX62/52/32	QX81/81/61
	QX31/31/22	QX43/31/31	QX51/43/43		QX62/52/52	QX81/81/81
	QX31/31/23	QX43/33/33	QX52/42/23		QX62/53/22	QX82/82/52
	QX31/31/31	QX41/41/33	QX52/42/42		QX62/53/23	QX82/82/62
	QX31/31/33	QX41/42/21	QX52/43/22		QX62/53/31	QX82/82/63
	QX31/32/22	QX41/42/23	QX52/43/23		QX62/53/33	QX83/83/53
	QX31/33/33	QX41/42/42	QX52/43/43		QX63/51/51	
	QX32/32/22	QX41/43/21	QX53/41/22		QX63/53/53	
	QX32/32/23	QX41/43/22	QX53/41/23		QX61/61/31	
	QX32/32/32	QX41/43/23	QX53/42/22		QX61/61/33	
	QX32/32/33	QX42/42/22	QX53/42/43		QX61/61/41	
	QX33/33/23	QX42/42/23	QX53/43/23		QX61/61/53	
	QX33/33/33	QX42/42/31	QX51/51/21*		QX61/62/42	
		QX42/42/32	QX51/51/32		QX61/62/63	
		QX42/42/33	QX51/51/33		QX61/63/32	
		QX42/42/42	QX51/52/32		QX61/63/33	
		QX42/42/43	QX51/52/33		QX61/63/41	
		QX43/43/43	QX51/52/42		QX61/63/42	
			QX51/52/43		QX62/62/33	
			QX51/53/22		QX62/62/43	
			QX51/53/23		QX62/62/53	
			QX51/53/31		QX62/62/62	
			QX51/53/33		QX62/62/63	
			QX51/53/41		QX62/63/63	
			QX51/53/43		QX63/63/32	
			QX51/53/52		QX63/63/43	
			QX52/52/23		QX63/63/53	
65	130	260	520	520	1050	2100

Max. permissible drive shaft torque [Nm]

* this pump is used as the ordering example in section 6.2

6.2 Ordering code for triple pumps

Triple pumps can only be supplied after consulting Bucher Hydraulics GmbH.

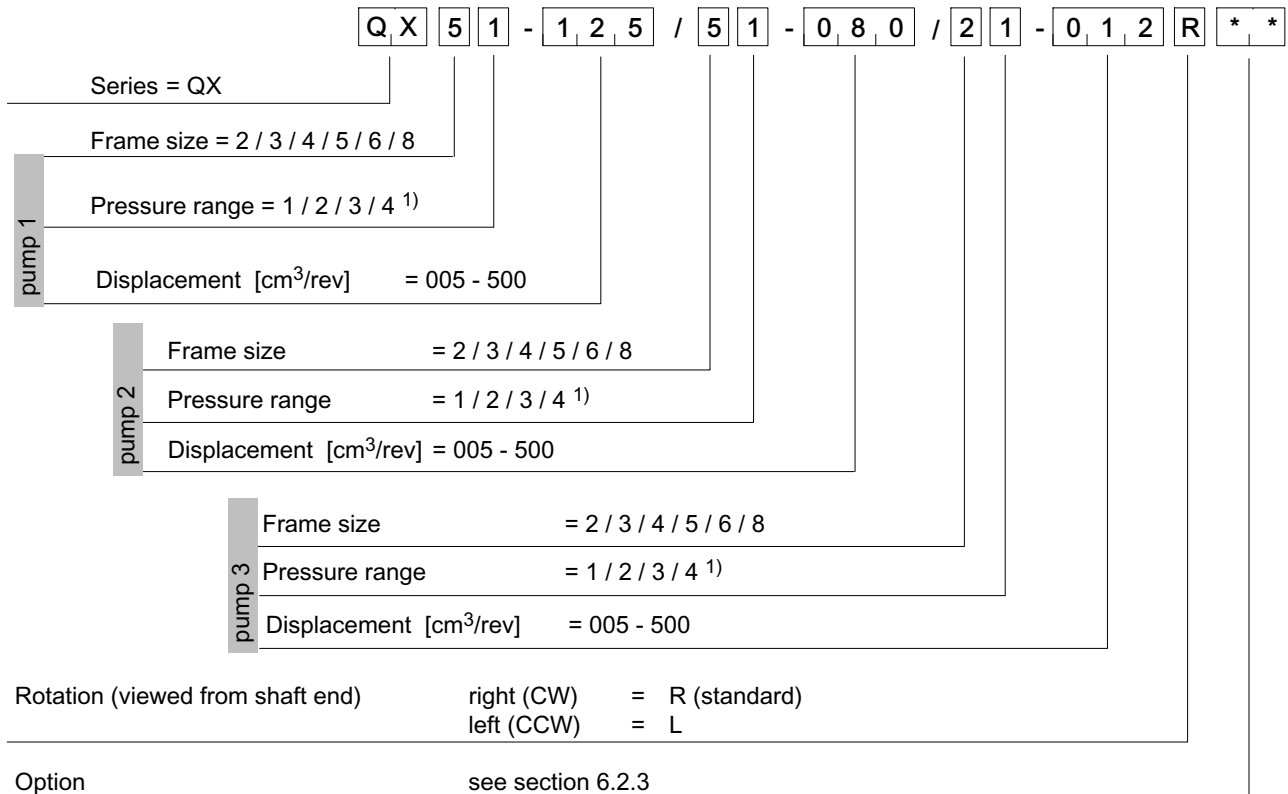

1) Pressure range 4 on request.

6.2.1 Ordering example:

Required: triple pump

Pump 1

Displacement: 125 cm³/rev
Continuous pressure: 80 bar
Type: 51-125

Pump 2

Displacement: 80 cm³/rev
Continuous pressure: 150 bar
Type: 51-080

Pump 3

Displacement: 12 cm³/rev
Continuous pressure: 125 bar
Type: 21-012

For use with mineral oil

Referring to the selection table in sect. 6.1, QX51/51/21 is an obtainable combination.

Ordering code: QX51-125/51-080/21-012R

6.2.2 Standard configuration

- direction of rotation - right (CW)
- 2-hole mounting flange to ISO 3019/1 (SAE): sizes QX 3-6
- 2-hole mounting flange to ISO 3019/2 (metr.): sizes QX 2+8
- nitrile seals
- parallel shaft end to ISO/R775
- black priming, flange without priming

6.2.3 Options

- O = without priming
- 06 = external drain port in the pump rear cover
QX 2-5 = G1/4", QX 6 = G3/8", QX 8 = G1/2"
- 09 = FKM (Viton) seals and without priming
- 12 = 2-hole mounting flange to ISO 3019/2 (metric): size QX 3-6
- 29 = for HFB and HFC fluids, frame sizes 2-5, without priming
- 66 = 4-hole mounting flange to ISO 3019/2 (metric)
- 83 = second suction port on:
QX51=SAE 1 1/4", QX61=SAE 2", QX81=SAE 2 1/2"
- 86 = for HFB and HFC fluids, frame sizes 6+8, without priming
- 117 = pressure port to SAE J518 code 61 / ISO 6162-1 can be supplied for frame size 2+3 with pressure ranges 2+3

Further options on request.

7 Low-flow capability pump in combination with other QX-single pumps

7.1 Dimensions

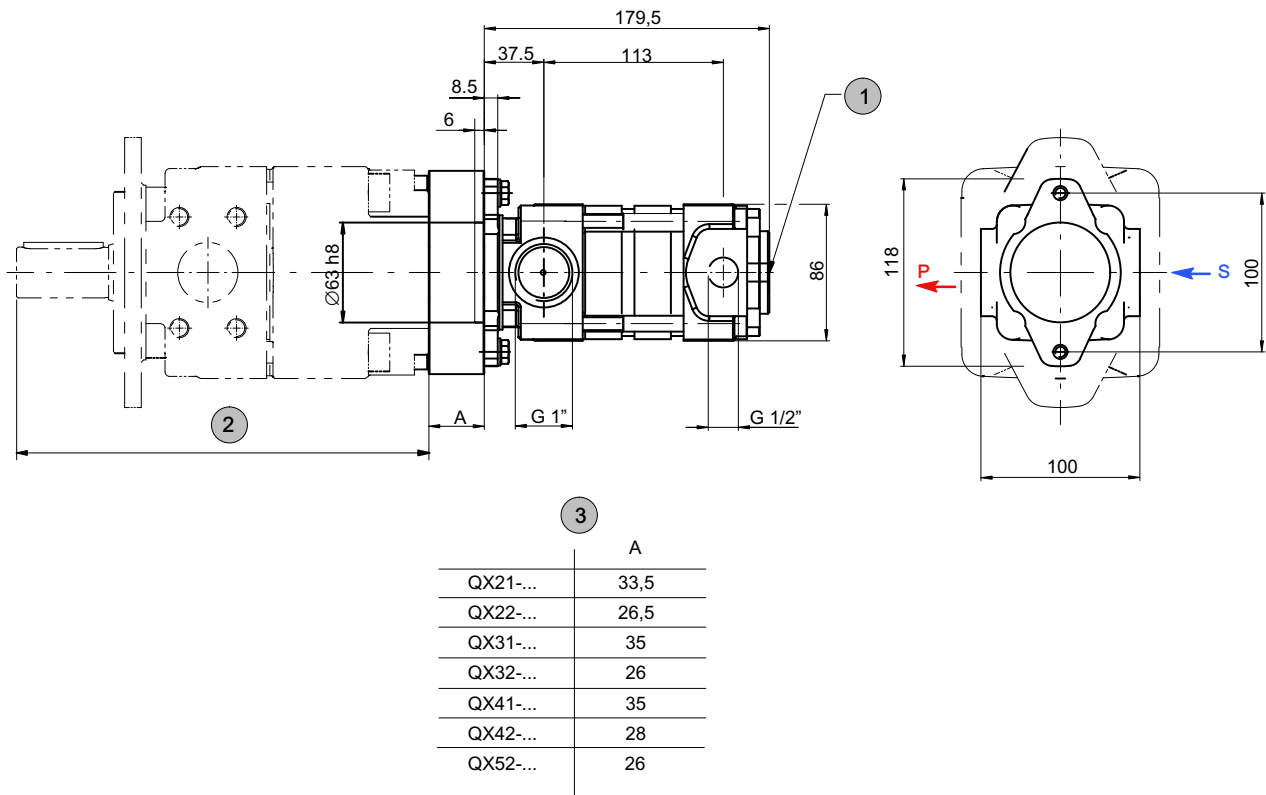

1	external drain port G 1/2"
2	dimensions see section 4

3	dimension A depends on the driving QX pump model (2)
---	--

7.2 Ordering code

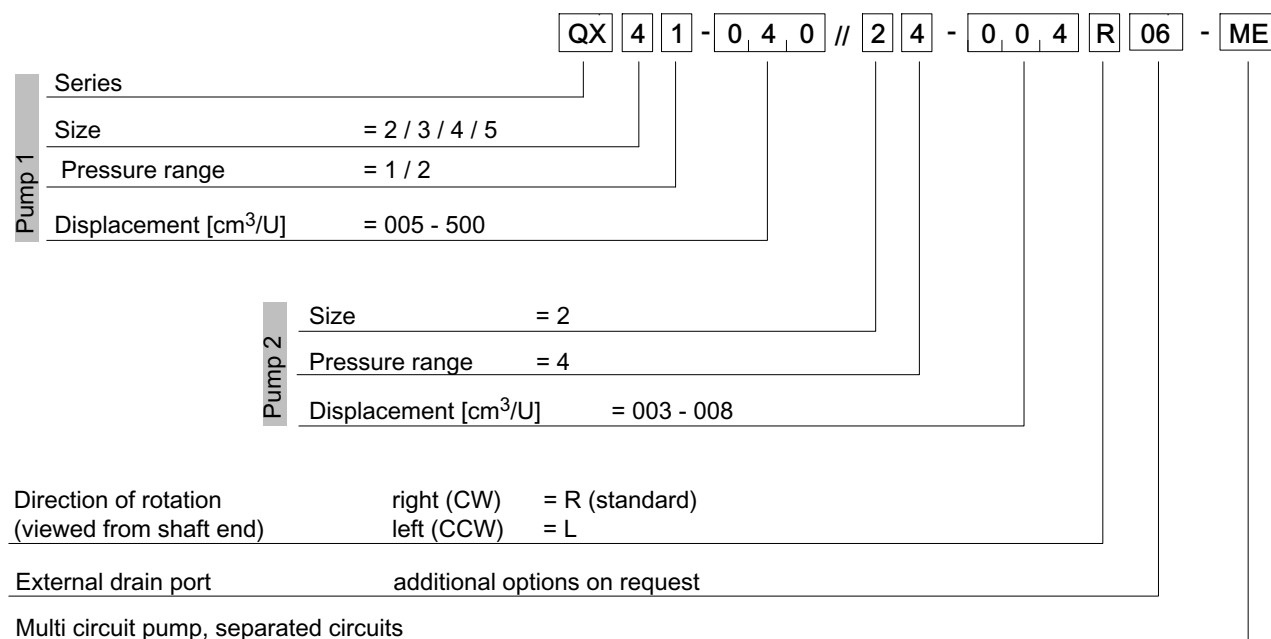

7.2.1 Ordering example:

Required:	Double pump		
Pump 1		Pump 2	
Displacement:	40 cm ³ /rev	Displacement:	4 cm ³ /rev
Continuous pressure:	160 bar	Continuous pressure:	250 bar
Type:	41 - 040	Type:	24 - 004
For use with mineral oil:			
Ordering code:	QX41-040//24-004R06-ME		

8 Fluid

QX pumps require fluid with a minimum cleanliness level of ISO 4406 code 20/18/15.

We recommend the use of fluids that contain anti-wear additives for mixed-friction operating conditions. Fluids without appropriate additives can reduce the service life of pumps and motors. The user is responsible for maintaining, and regularly checking, the fluid quality. Bucher Hydraulics recommends a load capacity of $\geq 30 \text{ N/mm}^2$ to Brügger DIN 51347-2.

9 Fluid cleanliness class

Cleanliness class (RK) onto ISO 4406 and NAS 1638

Code ISO 4406	Number of particles / 100 ml			
	$\geq 4 \mu\text{m}$	$\geq 6 \mu\text{m}$	$\geq 14 \mu\text{m}$	NAS 1638
23/21/18	8000000	2000000	250000	12
22/20/18	4000000	1000000	250000	-
22/20/17	4000000	1000000	130000	11
22/20/16	4000000	1000000	64000	-
21/19/16	2000000	500000	64000	10
20/18/15	1000000	250000	32000	9
19/17/14	500000	130000	16000	8
18/16/13	250000	64000	8000	7
17/15/12	130000	32000	4000	6
16/14/12	64000	16000	4000	-
16/14/11	64000	16000	2000	5
15/13/10	32000	8000	1000	4
14/12/9	16000	4000	500	3
13/11/8	8000	2000	250	2

10 Operational reliability

To guarantee the reliable operation and a long service life of the pump, a maintenance schedule must be prepared for the power unit, machine or system. The maintenance schedule must make sure that the provided or permissible operating conditions of the pump are adhered to over the period of use.

In particular, compliance with the following operating parameters must be ensured:

- required oil cleanliness
- operating temperature range
- fluid level

Moreover, the pump and the system must be inspected at regular intervals for changes in the following parameters:

- Vibration
- Noise
- Differential temperature of pump – fluid in the tank
- Foaming in the tank
- Leak tightness

Changes in these parameters indicate wear of components (e.g. drive motor, coupling, pump, etc.). The cause must be immediately pinpointed and eliminated.

To provide high operational reliability of the pump in the machine or system, we recommend continuous, automatic checks of the above parameters and an automatic shut-down in the case of changes that exceed the usual fluctuations within the provided operating range.





Make sure that the plastic components of the coupling will be exchanged regularly (no later than 5 years). The manufacturer's instructions must be given priority.

11 Note

This catalogue is intended for users with specialist knowledge. The user must check the suitability of the equipment described here in order to ensure that all of the conditions necessary for the safety and proper functioning of the system are fulfilled. If you have any doubts or questions concerning the use of these pumps, please consult Bucher Hydraulics GmbH.

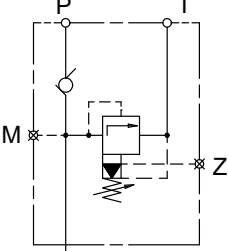
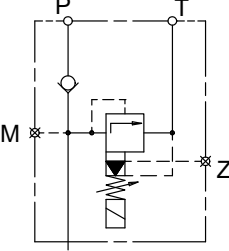
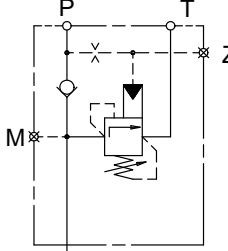
12 Accessories

12.1 Bolt-on valves - SAE J518 code 61 / ISO 6162-1 pattern

Pressure relief valve A S _G DF	Pressure relief valve solenoid control A S _G DA	Accumulator charging valve AGSF
		
		
<p>Technical data sheet 100-P-000123</p>	<p>Technical data sheet 100-P-000119</p>	<p>Technical data sheet 100-P-0000124</p>

12.1.1 Examples for Bolt-on valves, mounted on QX Internal Gear Pumps

Bolt-on valve with threaded ports AGDF	Bolt-on valves with pipe flanges SAE ¹⁾ ASDF+RF	Bolt-on valve with pipe flanges SAE + RVSAE ²⁾ ASDF+RF+RVSAE+DPSAE+ZPSAE
		

1) Pipe flange see section 12.2 and 12.3

2) Please ask Bucher Hydraulics GmbH for check valves

IMPORTANT: For detailed informations on Bolt-on valves see www.bucherhydraulics.com

12.2 Pipe flanges - high pressure type

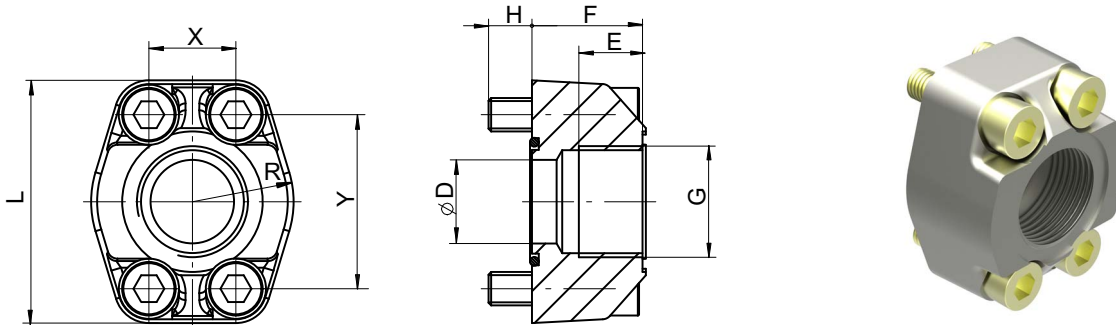

- Max. operating pressure 420 bar
- Flange size SAE J518 code 61 / ISO 6162-1

Threaded pipe flanges are spot-faced for DIN 2353 pipe fittings
 Material: ST37 / for Viton seals, contact Bucher Hydraulics GmbH

Ordering-number	Ordering code	Size	DØ	E	F	H	L	R	X	Y	Viton seal 90 Shore A	Retaining screws DIN912-12.9 / [Nm]	
100037000	RF 01-R08	G 1/2"	12,5	16	27	13	54	23	17,5	38	20,24x2,62	M8x30	30
100037010	RF 02-R10	G 3/4"	20	18	30	12	65	26	22,2	47,6	26,65x2,62	M10x30	60
100037020	RF 03-R11	G 1"	25	20	34	13	70	29	26,2	52,4	32,99x2,62	M10x35	60
100037030	RF 04-R12	G 1 1/4"	32	22	38	14	80	36	30,2	58,6	40,86x3,53	M10x40	60
100037040	RF 05-R13	G 1 1/2"	38	24	41	19	94	41	35,7	70	44,04x3,53	M12x45	120
100037050	RF 06-R14	G 2"	50	26	45	20	102	48	42,9	77,8	59,92x3,53	M12x50	120
100055470*	RF 07-R16	G 2 1/2" *	63	30	50	18	114	57	50,8	89	72,62x3,53	M12x45	120

* at RF07 only to 210 bar be allowed

12.3 Pipe flanges - low pressure type

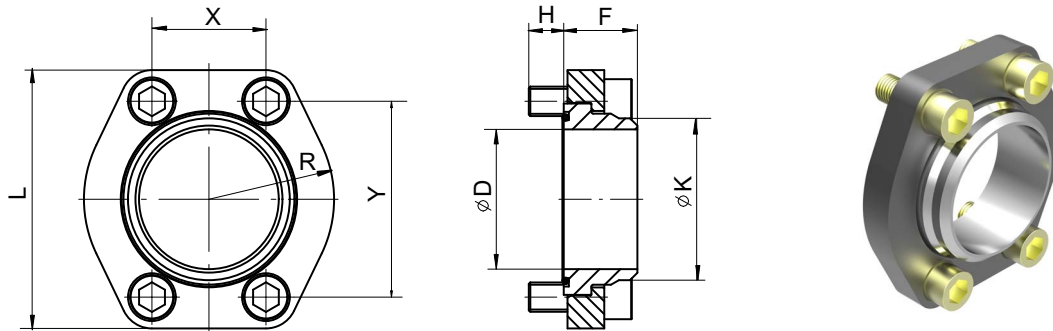

- Max. operating pressure 16 bar
- Flange size SAE J518 code 61 / ISO 6162-1

Material: HST37 / for Viton seals, contact Bucher Hydraulics GmbH

Ordering number	Ordering code	SAE flange Size	D	K	F	H	L	R	X	Y	Viton seal 90 Shore 'A'	Retaining screws DIN 912-8.8 Torque [Nm]		pipe ¹⁾ O/dia. approx.
100062450	RN 07-S	2½"	63	75	35	14	120	57	51	89	69,44x3,53	M12 x 30	70	75
100063880	RN 08-S	3"	76	88			140,5	68	62	106,5	85,32x3,53	M16 x 40	180	88
100063890	RN 09-S	3½"	89	100	40	19	158,5	73	70	120,3	98,02x3,53	M16 x 40	180	100
100063900	RN 10-S	4"	103	115			168	79	78	130	110,72x3,53	M16 x 40	180	115

1) We recommend the use of seamless precision steel tube to DIN 2391 with wallthick. max 6 mm