



- CV Check Valves
- SH Shuttle Valves
- LM Load/Motor Controls
- FC Flow Controls
- PC Pressure Controls
- LE Logic Elements
- DC Directional Controls
- MV Manual Valves
- SV Solenoid Valves
- PV Proportional Valves
- CE Coils & Electronics
- BC Bodies & Cavities
- TD Technical Data

**INTRODUCTION**

This technical tips section is designed to help familiarize you with the Parker line of Coils. In this section we highlight the features and discuss some of the available options. We also use this section to present some common terminology related to coil and coil technology.

# New Parker **SUPER COIL** Now Available!

**Class N Magnetic Wire**  
Internal wires have a class N rating, providing longer life at typical temperatures.

**DC Windings**  
All coils are DC wound. An internal full wave rectifier is added for AC current, eliminating inrush current, and allowing for voltage interchangeability.

**Variety of Terminations**  
Coils are offered in a wide variety of terminations, including integrally molded connectors and voltages to meet your system requirements.

**Rugged Thermoplastic Encapsulation**  
Coil is encased in a thermoplastic polyester resin. This allows for higher temperature exposure and less flexural creep. Also, this resin is resistant to moisture, caustic solutions, and fungus providing protection for coil windings.

**Low Carbon Steel Frame**  
Zinc plated low carbon steel frame surrounds coil, increasing flux density. Low carbon steel provides better magnetic properties and greater permeability.

**Diodes**  
Internally molded diodes are available. Polarity is molded into coil for ease of installation.

**Ribbed Surface**  
External ridges provide a larger coil surface area, which allows for better heat dissipation.

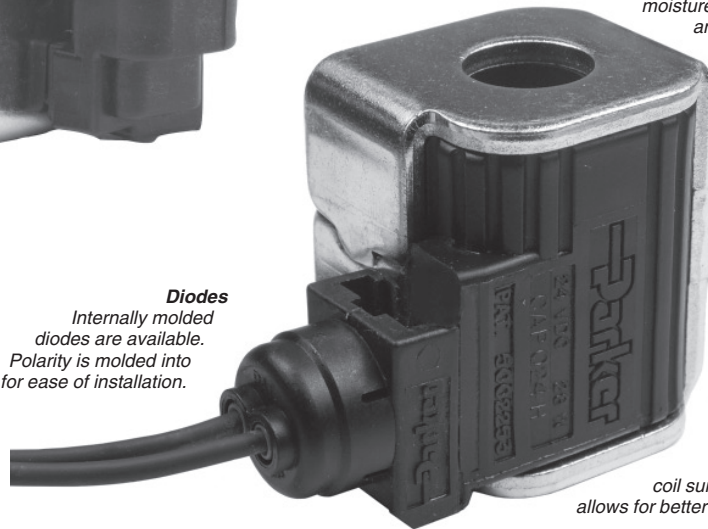

**\*Exceeds IP69k Specifications**

After exhaustive testing, the new Super Coil has clearly distanced itself from the competition. This coil was subjected to the rigors of this environmental standard and the results were excellent. This coil stands up to most rugged of environmental conditions including weather, dust, and extreme temperature variations.

**\*Water Dunk Test Qualified**

The Super Coil was taken to task in a repeated water dunk thermal cycle test program with alternate exposure to high and low temperature, only to perform with outstanding results.

**\*Endurance Tested**

The goal of this test was to cycle the coil to high temperature extremes in order to validate the coils ability to perform in extreme temperature environments.

**\*Water Spray and Chemical Solvent Compatibility**

The Super Coil was subjected to numerous chemical solvents in a rigorous test which established the fact that these coils can withstand harsh and unusual environments. Also, the coils were subjected to a high pressure water spray test. Once again, the Super Coil passed this test.

*\*Deutsch molded connector or LS option is highly recommended.*

**NOTE: LS coil option will be available January 1, 2011.**

**COMMON OPTIONS**

Below are some of the common options to the Unicoil product offering.

**Continuous Duty:** Parker's standard line of coils are rated for continuous duty operation. This means the coil can be left on continuously without fear of the magnet wire insulation breakdown, when used in standard climate conditions. The Unicoils and Super Coils are made of a high quality Class N magnet wire. This Class N rating signifies the internal wires are rated to 200°C (392°F).

Continuous duty does not mean the coil will have the same amount of power after hours of operation as it had at initial actuation. Coils do heat up during use. This internal heat rise increases the resistance of the coil and thus, decreases the current ( $V = IR$ ). The performance curves presented on the solenoid valve pages are based on a coil at room temperature and 85% of voltage. Thus, when using a valve in continuous duty applications, you may need to derate the performance. In short, the continuous duty rating signifies that while the coil will get hot during use and resistance will increase, it will not generate enough heat to damage the coil.

**Terminations:** Parker offers a wide variety of coil terminations for all coils to meet the demands of your application. Over the years, the dual lead wire and dual spade offerings have been popular due to their ease of installation and availability. In the past few years, the demand for more secure termination connections has increased. In addition, the integral connectors reduce cost and improve integrity by reducing the number of connections. As such, the Amp Junior, Weatherpack, Metri-Pack, and Deutsch have increased in popularity. We offer these connectors on a lead wire coil, as well as an internally molded version of the DIN, Amp Junior, and Metri-Pack coils. If you do not find your desired coil termination in our catalog, contact your factory sales representative. We have added a Sealed Leadwire option to meet IP69K requirements yet still allow for other lead wire options.

**Current Types:** Both direct current (DC) and alternating current (AC) versions are available for the Parker line of coils. The AC versions are essentially DC coils with a full wave rectifier integrally molded into the coil. The rectifiers are rated for voltage peaks up to 1000 volts maximum. For voltage transients greater than 1000 volts, a Harris Thyrector is recommended. The AC coils operate at 50/60 cycles (Hz). Since the AC versions are rectified

DC coils, there is no inrush current like with "true" AC coils. It also means DC coils and AC coils are interchangeable.

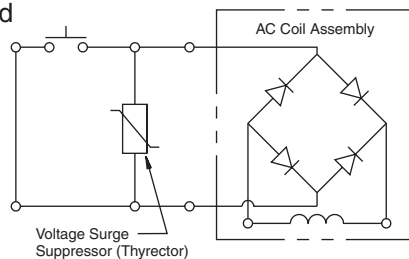

**Voltages:** Parker has a wide selection of coils available to meet your needs. Most coil terminations are available with our standard voltages of 12V and 24V in DC, and 120V and 240V in AC. Voltages 6V, 10V, 18V, 36V, 48V DC and 440V AC are also available for many termination types at a slight premium. Contact your Parker representative should your application call for voltages other than our standard offering.

**Diodes:** The Parker Coils can be ordered with a diode molded internally. Parker Unicoils use a 1N5062 diode. The Super Coils use a 1N5627 diode. Diodes are sometimes used to protect sensitive, downstream electrical components from potential surges from the coil. By internally molding the diode into the coil, you can reduce the assembly time and cost associated with externally wiring a diode. One should be careful not to switch the polarity ("+" and "-" terminals), when wiring a coil with an internal diode. If these terminals are switched, the first time voltage is applied to the coil; the short circuit will destroy the diode and render the coil use-less. Parker coils with diodes have "+" and "-" molded near the termination outlet to help identify polarity.

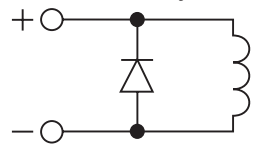

**DIN Connectors:** Parker does offer connectors for use with the DIN style coils. As shown below, the DIN connectors are available in both rectified and non-rectified forms. The cable gland versions can be ordered for type PG9 or PG11.

**Cable Gland**

| Type | Non-Rectified | Rectified |
|------|---------------|-----------|
| PG9  | 710549-00     | 712126-01 |
| PG11 | 710549-01     | 712126-00 |

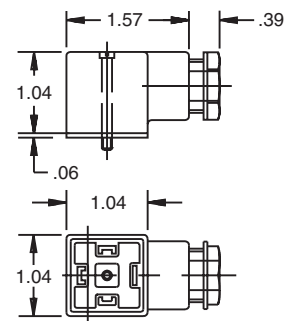

| Conduit | Rectified |
|---------|-----------|
|         | 712704-00 |

| Conduit | Non-Rectified |
|---------|---------------|
|         | 710549-02     |

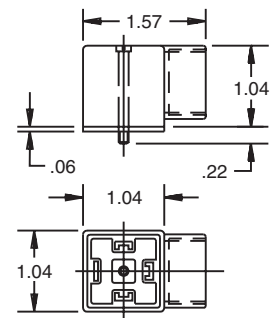
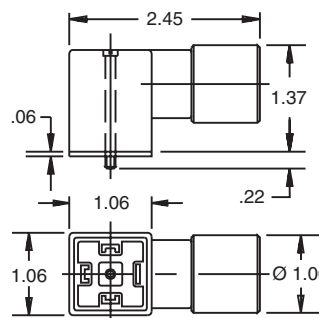

Technical Information

- CV Check Valves
- SH Shuttle Valves
- LM Load/Motor Controls
- FC Flow Controls
- PC Pressure Controls
- LE Logic Elements
- DC Directional Controls
- MV Manual Valves
- SV Solenoid Valves
- PV Proportional Valves
- CE Coils & Electronics
- BC Bodies & Cavities
- TD Technical Data

Features

- Integral Deutsch connector coil exceeds IP69K standards
- Integral Deutsch connector coil thermal shock dunk test rated
- Integral Amp Jr. coil exceeds IP67 standards for thermal shock, water resistance and "dunk capability"
- Universal 50/60 Hz operation
- Waterproof coil hermetically sealed, requires no O-rings or waterproofing kits
- External plated steel flux-carrying band (unlike encapsulated band) enables coil to withstand severe thermal shocks without cracking
- Symmetrical coil can be reversed without affecting performance

Specifications

|   |   |                       |
|---|---|-----------------------|
| <b>Coil Type</b>  | <b>S</b> Standard   | <b>P</b> Puissant     |
| <b>Nominal Wattage (See Ordering Information For Exact Wattage)</b> | <b>S</b> 14 Watts   | <b>P</b> 19 Watts     |
| <b>Duty Cycle</b>   | Continuous @ 100% voltage   |                       |
| <b>Magnetic Wire Insulation Class</b>                               | 'N' Rated at 200°C (392°F)  |                       |
| <b>Temperature Range</b>  | -40°C to +200°C (-40°F to +392°F)   |                       |
| <b>Temperature Rise At Nominal Voltage And Natural Ventilation</b>  | <b>S</b> 75°C (135°F)   | <b>P</b> 95°C (172°F) |
| <b>Dielectric Strength Maximum Current Leakage (Amps)</b>           | .0005 In dry lab condition at 1000V AC for 30 seconds<br>.001 After being immersed in 23°C (77°F) water with waterproof connector for 24 hours at 500V AC |                       |
| <b>Encapsulating Material</b>                                       | Glass filled rynite   |                       |
| <b>Color Identification On The Terminal Boss</b>                    | <b>S</b> Black Ring   | <b>P</b> Red Ring     |
| <b>Weight</b>   | 0.20 kg (0.44 lbs.)   |                       |

AC Coil Assembly

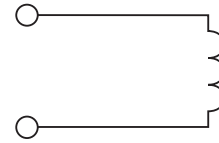
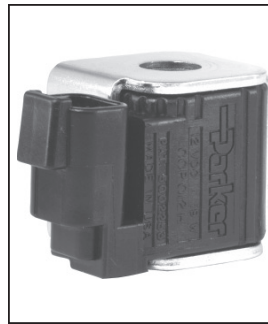
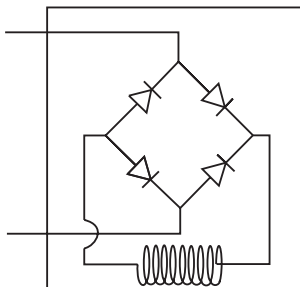

Ordering Information

**CC** Super Coil 1/2" I.D.    **Wattage**    **Voltage**    **Termination**

| Code     | Wattage  |
|----------|----------|
| <b>S</b> | Standard |
| <b>P</b> | Puissant |

| Code        | Voltage | Watts |    | Amps |      | Ohms** |       |
|-------------|---------|-------|----|------|------|--------|-------|
|             |         | S     | P  | S    | P    | S      | P     |
| <b>010</b>  | 10 VDC  | 14    | 19 | 1.38 | 1.90 | 7.25   | 5.26  |
| <b>012*</b> | 12 VDC  | 14    | 19 | 1.15 | 1.58 | 10.43  | 7.58  |
| <b>018</b>  | 18 VDC  | 14    | 19 | 0.77 | 1.06 | 23.48  | 17.05 |
| <b>024*</b> | 24 VDC  | 14    | 19 | 0.58 | 0.79 | 41.74  | 30.30 |
| <b>048</b>  | 48 VDC  | 14    | 19 | 0.29 | 0.40 | 167.0  | 121.3 |
| <b>115*</b> | 115 VAC | 16    | 19 | 0.17 | 0.20 | 680    | 576   |
| <b>230</b>  | 230 VAC | 17    | 22 | 0.09 | 0.12 | 2596   | 1919  |

\*Standard Voltages    \*\*Resistance ±10% at 68°F

| Code      | Termination  |
|-----------|--|
| <b>A</b>  | Amp Jr. (DC Only)  |
| <b>AD</b> | Amp Jr. with 3 Amp Diode (DC Only)   |
| <b>C</b>  | Double Lead Wire with Conduit Connector (AC Only)                                      |
| <b>*D</b> | DIN 43650 (AC or DC, Supplied without DIN Connector)                                   |
| <b>H</b>  | Integral Deutsch   |
| <b>HE</b> | Integral Deutsch with 3 Amp Diode  |
| <b>*L</b> | Double Lead (DC Only)  |
| <b>LS</b> | Sealed Lead Wire IP69K Rated (Available January 1, 2011)                               |
| <b>LD</b> | Double Lead with Deutsch Connector DT04-2P-EP04 (DC Only) (Use 'H' series if possible) |
| <b>LE</b> | Double Lead with 3 Amp Diode (DC Only)   |
| <b>PF</b> | Double Lead Wire with Packard Female Weather Pack Connector 1201 5792 (DC Only)        |
| <b>PM</b> | Double Lead Wire with Packard Male Weather Pack Connector 1201 0973 (DC Only)          |
| <b>*S</b> | Double Spade (DC Only)   |
| <b>*W</b> | Double Screw (DC only)   |
| <b>WE</b> | Double Screw with 3 Amp Diode (DC Only)  |
| <b>*Y</b> | Single Screw (Internally Grounded, DC Only)  |

\*UL listed 12/24/48 VDC only.

Note: Additional voltages and other terminals are available. Some coils are UL approved. For details please consult factory.

DIN Female Mating Connector: See page CE2

Deutsch Mating Connector: # DT06-2S

Packard Male Weather Pack Connector: 12010973

Packard Female Weather Pack Connector: 12015792

**Terminal Styles and Dimensions**

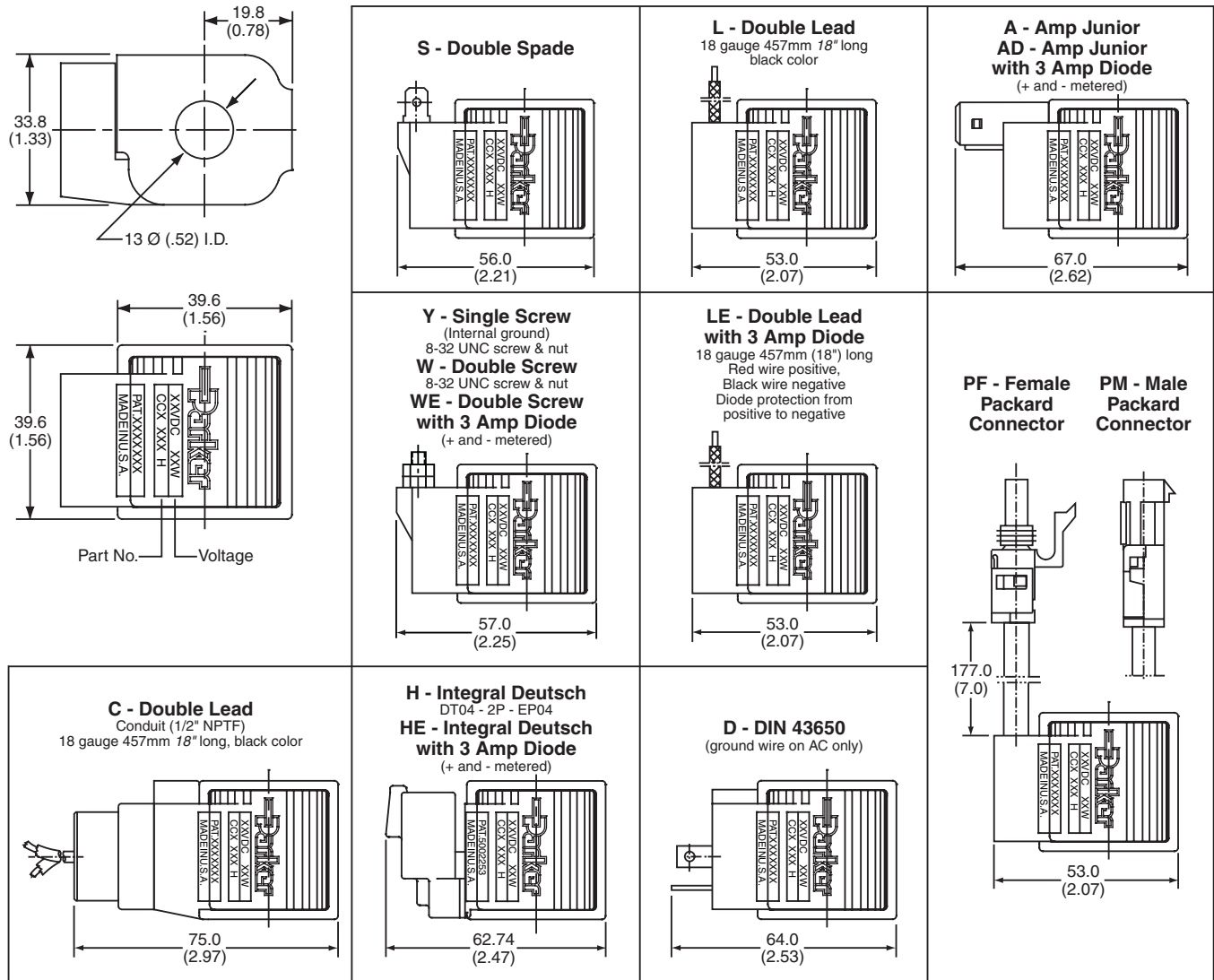

- NOTES:**
1. The standard A.C. coil includes a molded-in full wave rectifier rated for 800 peak reverse voltage.
  2. All P Puissant (high wattage) coils use a red ring as an indication marker on the terminal boss.



- CV** Check Valves
- SH** Shuttle Valves
- LM** Load/Motor Controls
- FC** Flow Controls
- PC** Pressure Controls
- LE** Logic Elements
- DC** Directional Controls
- MV** Manual Valves
- SV** Solenoid Valves
- PV** Proportional Valves
- CE** Coils & Electronics
- BC** Bodies & Cavities
- TD** Technical Data

Technical Information

- CV Check Valves
- SH Shuttle Valves
- LM Load/Motor Controls
- FC Flow Controls
- PC Pressure Controls
- LE Logic Elements
- DC Directional Controls
- MV Manual Valves
- SV Solenoid Valves
- PV Proportional Valves
- CE Coils & Electronics
- BC Bodies & Cavities
- TD Technical Data

Features

- Integral Deutsch connector coil exceeds IP69K standards
- Integral Deutsch connector coil thermal shock dunk test rated
- Integral Amp Jr. coil exceeds IP67 standards for thermal shock, water resistance and "dunk capability"
- Universal 50/60 Hz operation
- Coil hermetically sealed, requires no O-rings or waterproofing kits
- External plated steel flux-carrying band (unlike encapsulated band) enables coil to withstand severe thermal shocks without cracking
- Symmetrical coil can be reversed without affecting performance

Specifications

|  |  |              |
|--|--|--------------|
| Coil Type  | S  | Standard     |
|  | P  | Puissant     |
| Nominal Wattage (See Ordering Information For Exact Wattage) | S  | 18 Watts     |
|  | P  | 28 Watts     |
| Duty Cycle   | Continuous @ 100% voltage  |              |
| Magnetic Wire Insulation Class                               | 'N' Rated at 200°C (392°F)   |              |
| Temperature Range  | -40°C to +200°C (-40°F to +392°F)  |              |
| Temperature Rise At Nominal Voltage And Natural Ventilation  | S  | 75°C (135°F) |
|  | P  | 95°C (172°F) |
| Dielectric Strength Maximum Current Leakage (Amps)           | .0005 In dry lab condition at 1000V AC for 30 seconds  |              |
|  | .001 After being immersed in 23°C (77°F) water with waterproof connector for 24 hours at 500V AC |              |
| Encapsulating Material                                       | Glass filled rynite  |              |
| Color Identification On The Terminal Boss                    | S  | Black Ring   |
|  | P  | Red Ring     |
| Weight   | 0.29 kg (0.64 lbs.)  |              |

AC Coil Assembly

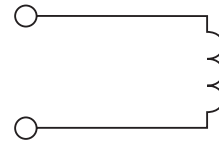
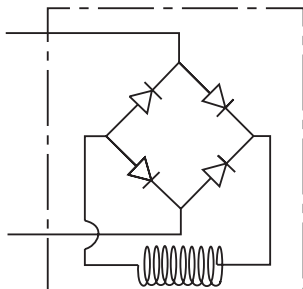

Ordering Information

|                         |         |         |             |
|-------------------------|---------|---------|-------------|
| <b>CA</b>               | Wattage | Voltage | Termination |
| Super Coil<br>5/8" I.D. |         |         |             |

|      |          |
|------|----------|
| Code | Wattage  |
| S    | Standard |
| P    | Puissant |

| Code | Voltage | Watts |    | Amps |      | Ohms** |      |
|------|---------|-------|----|------|------|--------|------|
|      |         | S     | P  | S    | P    | S      | P    |
| 010  | 10 VDC  | 18    | 28 | 1.80 | 2.80 | 5.56   | 3.57 |
| 012* | 12 VDC  | 18    | 28 | 1.50 | 2.33 | 8.00   | 5.14 |
| 018  | 18 VDC  | 18    | 28 | 1.00 | 1.56 | 18.0   | 11.6 |
| 024* | 24 VDC  | 18    | 28 | 0.75 | 1.17 | 32.0   | 20.6 |
| 048  | 48 VDC  | 18    | 28 | 0.38 | 0.58 | 128.0  | 82.3 |
| 115* | 115 VAC | 18    | 28 | 0.20 | 0.26 | 554    | 417  |
| 230  | 230 VAC | 18    | 28 | 0.10 | 0.15 | 2100   | 1430 |

\*Standard Voltages      \*\*Resistance ±10% at 68°F

| Code | Termination  |
|------|--|
| A    | Amp Jr. (DC Only)  |
| AD   | Amp Jr. with 3 Amp Diode (DC Only)   |
| C    | Double Lead Wire with Conduit Connector (AC Only)                                      |
| *D   | DIN 43650 (AC or DC, Supplied without DIN Connector)                                   |
| H    | Integral Deutsch   |
| HE   | Integral Deutsch with 3 Amp Diode  |
| HS   | Integral Deutsch with Internal Seal  |
| *L   | Double Lead (DC Only)  |
| LS   | Sealed Lead Wire IP69K Rated (Available January 1, 2011)                               |
| LD   | Double Lead with Deutsch Connector DT04-2P-EP04 (DC Only) (Use 'H' series if possible) |
| LE   | Double Lead with 3 Amp Diode (DC Only)   |
| PF   | Double Lead Wire with Packard Female Weather Pack Connector 1201 5792 (DC Only)        |
| PM   | Double Lead Wire with Packard Male Weather Pack Connector 1201 0973 (DC Only)          |
| *S   | Double Spade (DC Only)   |
| *W   | Double Screw (DC only)   |
| WE   | Double Screw with 3 Amp Diode (DC Only)  |
| *Y   | Single Screw (Internally Grounded, DC Only)  |

\*UL listed 12/24/48 VDC only.

Note: Additional voltages and other terminals are available. Some coils are UL approved. For details please consult factory.

DIN Female Mating Connector: See page CE2

Deutsch Mating Connector: # DT06-2S

Packard Male Weather Pack Connector: 12010973

Packard Female Weather Pack Connector: 12015792

**Terminal Styles and Dimensions**

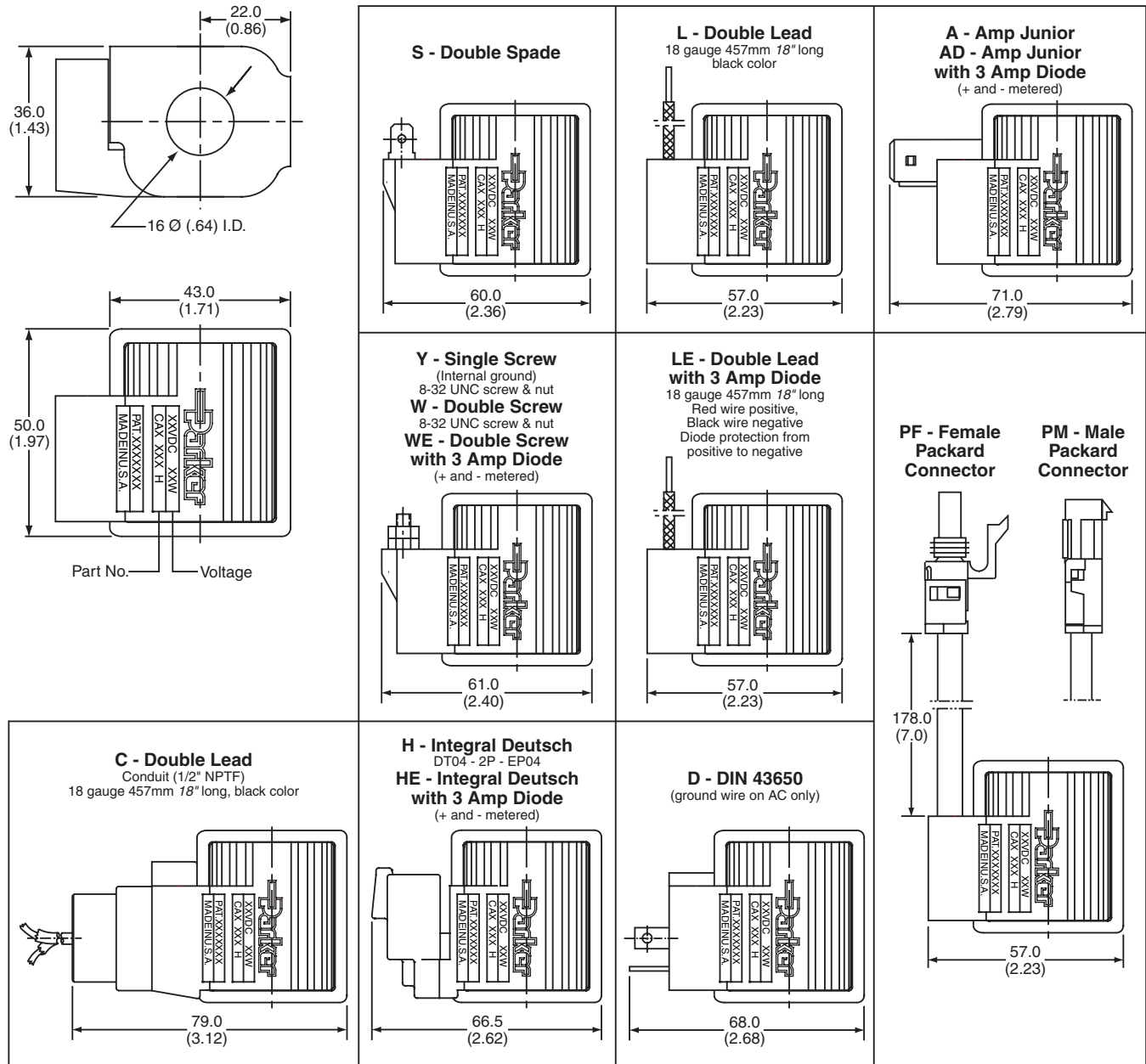

**NOTES:**

1. The standard A.C. coil includes a molded-in full wave rectifier rated for 800 peak reverse voltage.
2. All P Puissant (high wattage) coils use a red ring as an indication marker on the terminal boss. (No ring on Integral Deutsch connector.)

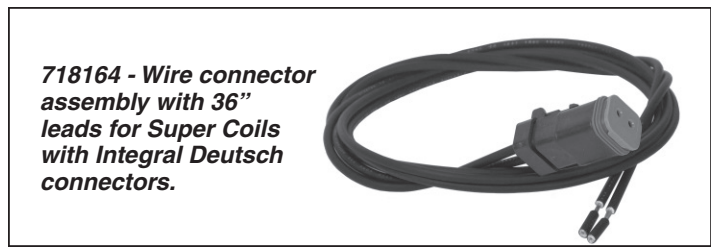

- CV** Check Valves
- SH** Shuttle Valves
- LM** Load/Motor Controls
- FC** Flow Controls
- PC** Pressure Controls
- LE** Logic Elements
- DC** Directional Controls
- MV** Manual Valves
- SV** Solenoid Valves
- PV** Proportional Valves
- CE** Coils & Electronics
- BC** Bodies & Cavities
- TD** Technical Data

Technical Information

- CV** Check Valves
- SH** Shuttle Valves
- LM** Load/Motor Controls
- FC** Flow Controls
- PC** Pressure Controls
- LE** Logic Elements
- DC** Directional Controls
- MV** Manual Valves
- SV** Solenoid Valves
- PV** Proportional Valves
- CE** Coils & Electronics
- BC** Bodies & Cavities
- TD** Technical Data

Features

- Compact one piece encapsulated design
- Minimal amperage draw
- Numerous terminals and voltages
- Coil designed for use with series DSL and DSH type valves only
- Coils made with high quality Class N magnet wire
- Superior thick internal iron frame surrounding copper windings to increase the flux density
- More ampere turns to deliver more magnetic flux per input voltage
- A.C. coil operates @ 50/60 cycle (Hz)

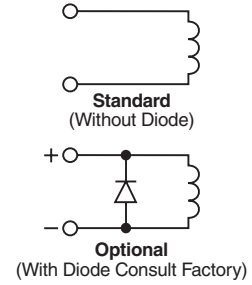
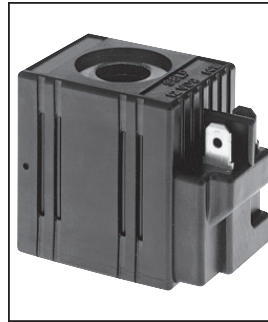

Specifications

|                                |  |
|--------------------------------|--|
| <b>Wattage</b>                 | 14 Watts   |
| <b>Duty Rating</b>             | Continuous @ 100% voltage  |
| <b>Wire Class</b>              | Class N - 200°C (392°F)  |
| <b>Heat Rise</b>               | 45°C (115°F) over ambient  |
| <b>A.C. Rectifier</b>          | Integral full wave bridge  |
| <b>Lead Wire</b>               | 18 gauge 24" long, 600 volt rating   |
| <b>Lead Wire Strain Relief</b> | 34 kg (75 lbs.) @ 21°C (70°F) & 18 kg (40 lbs.) @ 93°C (200°F)   |
| <b>Encapsulating Material</b>  | Rynite, resistant to moisture, caustic solutions, fungus, and temperatures from -40°C (-40°F) to 200°C (392°F) |
| <b>Finish</b>                  | Coil - Black<br>Frame - Yellow zinc dichromate   |

Coil Accessories For DIN Connector 43650

Cable Gland

| Type | Non-Rectified | Rectified |
|------|---------------|-----------|
| PG9  | 710549-00     | 712126-01 |
| PG11 | 710549-01     | 712126-00 |

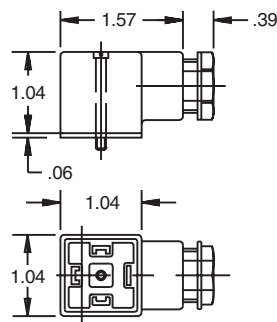

Conduit

| Rectified |
|-----------|
| 712704-00 |

Conduit

| Non-Rectified |
|---------------|
| 710549-02     |

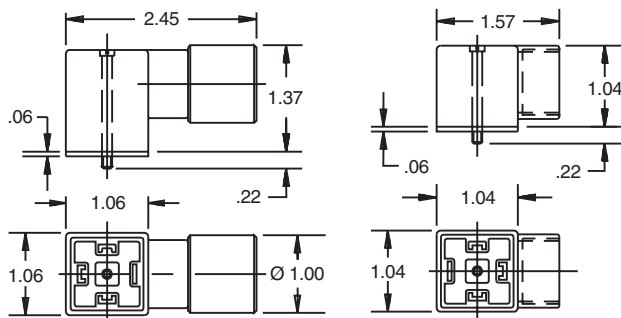

Ordering Information

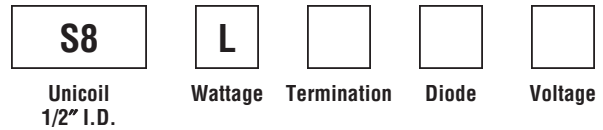

| Code | Wattage |
|------|---------|
| L    | 14 Watt |

| Code | Diode         |
|------|---------------|
| Omit | Without Diode |
| R    | Diode         |

Diode not available with all connectors.

| Code | Termination             |
|------|-------------------------|
| C    | *Conduit With Leads     |
| D    | *DIN Plug Face          |
| J    | Amp Jr.                 |
| M    | Metri-Pack              |
| P    | *Dual Spade             |
| S    | *Dual Screw             |
| W    | Dual Lead (DC Only)     |
| WS   | Weather Pack Shroud 24" |

\*Diode not available

| Code  | Voltage | Current Amps | Resistance Ohms | Lead Color |
|-------|---------|--------------|-----------------|------------|
| *D006 | 6 VDC   | 2.40         | 2.5             | Black      |
| *D010 | 10 VDC  | 1.45         | 6.9             | Yellow     |
| D012  | 12 VDC  | 1.17         | 10.2            | Red        |
| *D018 | 18 VDC  | 0.84         | 21.5            | Gray       |
| D024  | 24 VDC  | 0.57         | 41.8            | Blue       |
| *D036 | 36 VDC  | 0.45         | 80.5            | Orange     |
| *D048 | 48 VDC  | 0.32         | 150.6           | Green      |
| A120  | 120 VAC | 0.16         | 663             | Brown      |
| A240  | 240 VAC | 0.07         | 3032            | White      |

\* Consult Factory.



**Terminal Styles and Dimensions**

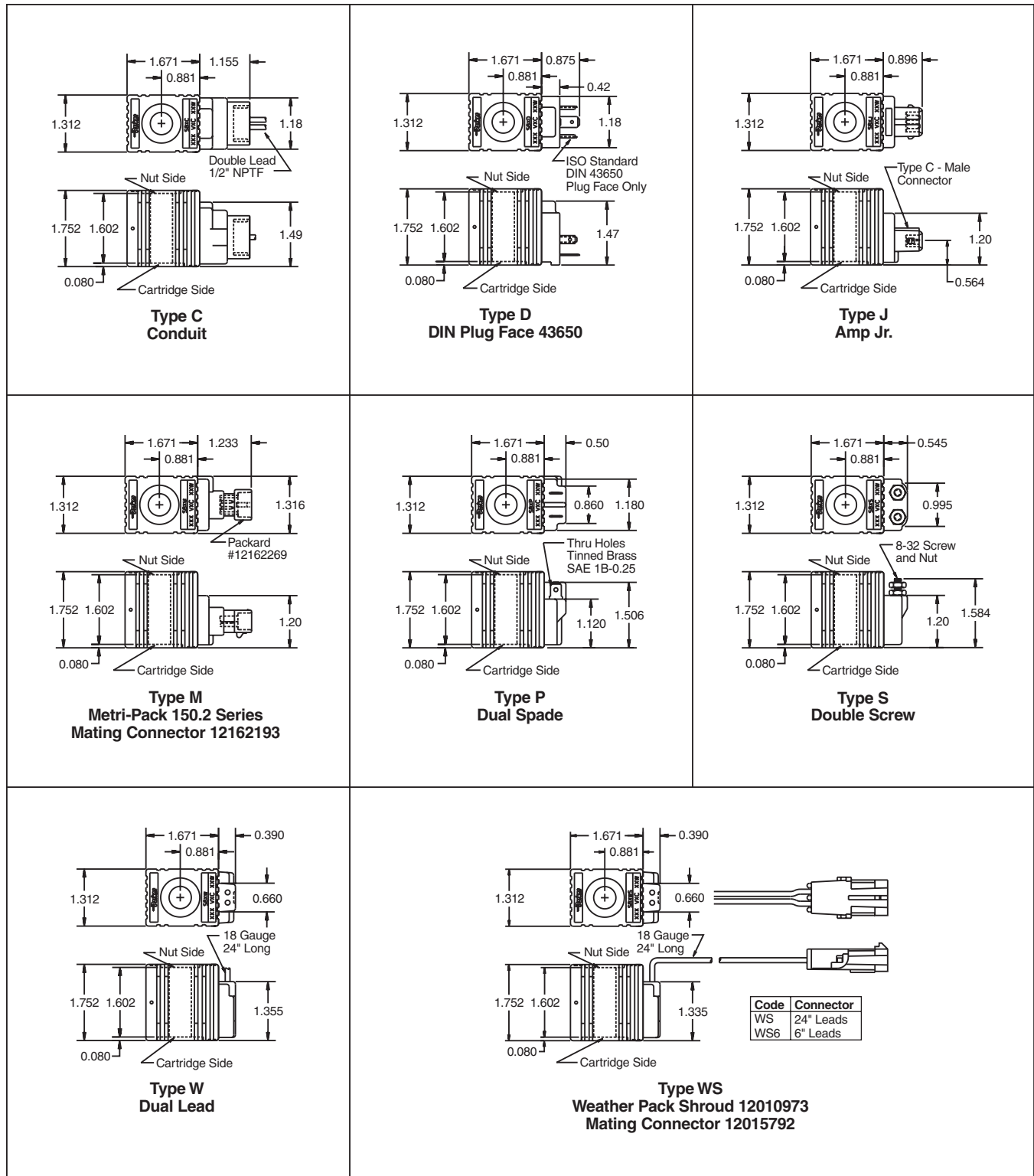

**CV**  
Check Valves

**SH**  
Shuttle Valves

**LM**  
Load/Motor Controls

**FC**  
Flow Controls

**PC**  
Pressure Controls

**LE**  
Logic Elements

**DC**  
Directional Controls

**MV**  
Manual Valves

**SV**  
Solenoid Valves

**PV**  
Proportional Valves

**CEI**  
Coils & Electronics

**BC**  
Bodies & Cavities

**TD**  
Technical Data

Technical Information

- CV** Check Valves
- SH** Shuttle Valves
- LM** Load/Motor Controls
- FC** Flow Controls
- PC** Pressure Controls
- LE** Logic Elements
- DC** Directional Controls
- MV** Manual Valves
- SV** Solenoid Valves
- PV** Proportional Valves
- CE** Coils & Electronics
- BC** Bodies & Cavities
- TD** Technical Data

Features

- Compact one piece encapsulated design
- Minimal amperage draw
- Numerous terminals and voltages
- Coil designed for use with series DSL and DSH type valves only
- Coils made with high quality Class N magnet wire
- Superior thick internal iron frame surrounding copper windings to increase the flux density
- More ampere turns to deliver more magnetic flux per input voltage
- A.C. coil operates @ 50/60 cycle (Hz)

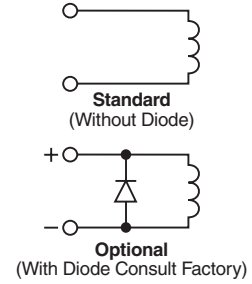
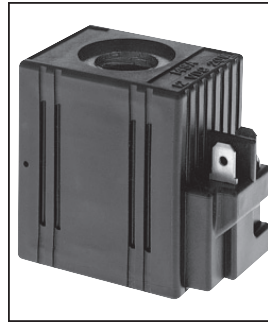

Specifications

|                                |  |
|--------------------------------|--|
| <b>Wattage</b>                 | 20 Watts   |
| <b>Duty Rating</b>             | Continuous @ 100% voltage  |
| <b>Wire Class</b>              | Class N - 200°C (392°F)  |
| <b>Heat Rise</b>               | 45°C (115°F) over ambient  |
| <b>A.C. Rectifier</b>          | Integral full wave bridge  |
| <b>Lead Wire</b>               | 18 gauge 24" long, 600 volt rating   |
| <b>Lead Wire Strain Relief</b> | 34 kg (75 lbs.) @ 21°C (70°F) & 18 kg (40 lbs.) @ 93°C (200°F)   |
| <b>Encapsulating Material</b>  | Rynite, resistant to moisture, caustic solutions, fungus, and temperatures from -40°C (-40°F) to 200°C (392°F) |
| <b>Finish</b>                  | Coil - Black<br>Frame - Yellow zinc dichromate   |

Coil Accessories For DIN Connector 43650

Cable Gland

| Type | Non-Rectified | Rectified |
|------|---------------|-----------|
| PG9  | 710549-00     | 712126-01 |
| PG11 | 710549-01     | 712126-00 |

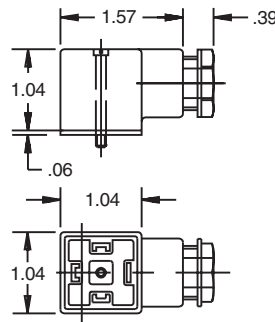

Conduit

| Rectified |
|-----------|
| 712704-00 |

Conduit

| Non-Rectified |
|---------------|
| 710549-02     |

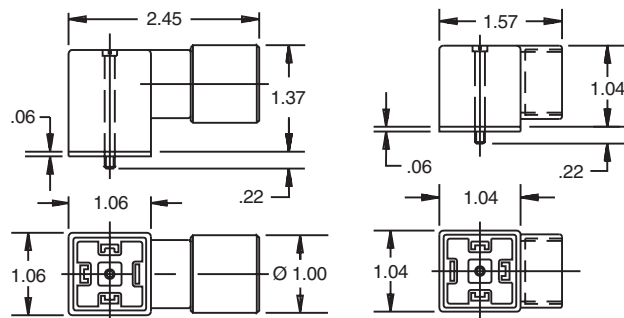

Ordering Information

|                      |          |             |       |         |
|----------------------|----------|-------------|-------|---------|
| <b>S10</b>           | <b>L</b> |             |       |         |
| Unicoil<br>5/8" I.D. | Wattage  | Termination | Diode | Voltage |

| Code | Wattage |
|------|---------|
| L    | 20 Watt |

| Code | Diode         |
|------|---------------|
| Omit | Without Diode |
| R    | Diode         |

Diode not available with all connectors.

| Code | Termination             |
|------|-------------------------|
| C    | *Conduit With Leads     |
| D    | *DIN Plug Face          |
| J    | Amp Jr.                 |
| M    | Metri-Pack              |
| P    | *Dual Spade             |
| S    | *Dual Screw             |
| W    | Dual Lead (DC Only)     |
| WS   | Weather Pack Shroud 24" |

\*Diode not available

| Code  | Voltage | Current Amps | Resistance Ohms | Lead Color |
|-------|---------|--------------|-----------------|------------|
| *D006 | 6 VDC   | 3.33         | 1.8             | Black      |
| *D010 | 10 VDC  | 2.10         | 4.8             | Yellow     |
| D012  | 12 VDC  | 1.67         | 7.2             | Red        |
| *D018 | 18 VDC  | 1.21         | 14.9            | Gray       |
| D024  | 24 VDC  | 0.88         | 27.4            | Blue       |
| *D036 | 36 VDC  | 0.61         | 58.9            | Orange     |
| *D048 | 48 VDC  | 0.47         | 102.4           | Green      |
| A120  | 120 VAC | 0.192        | 626             | Brown      |
| A240  | 240 VAC | 0.10         | 2400            | White      |

\* Consult Factory.

**Terminal Styles and Dimensions**

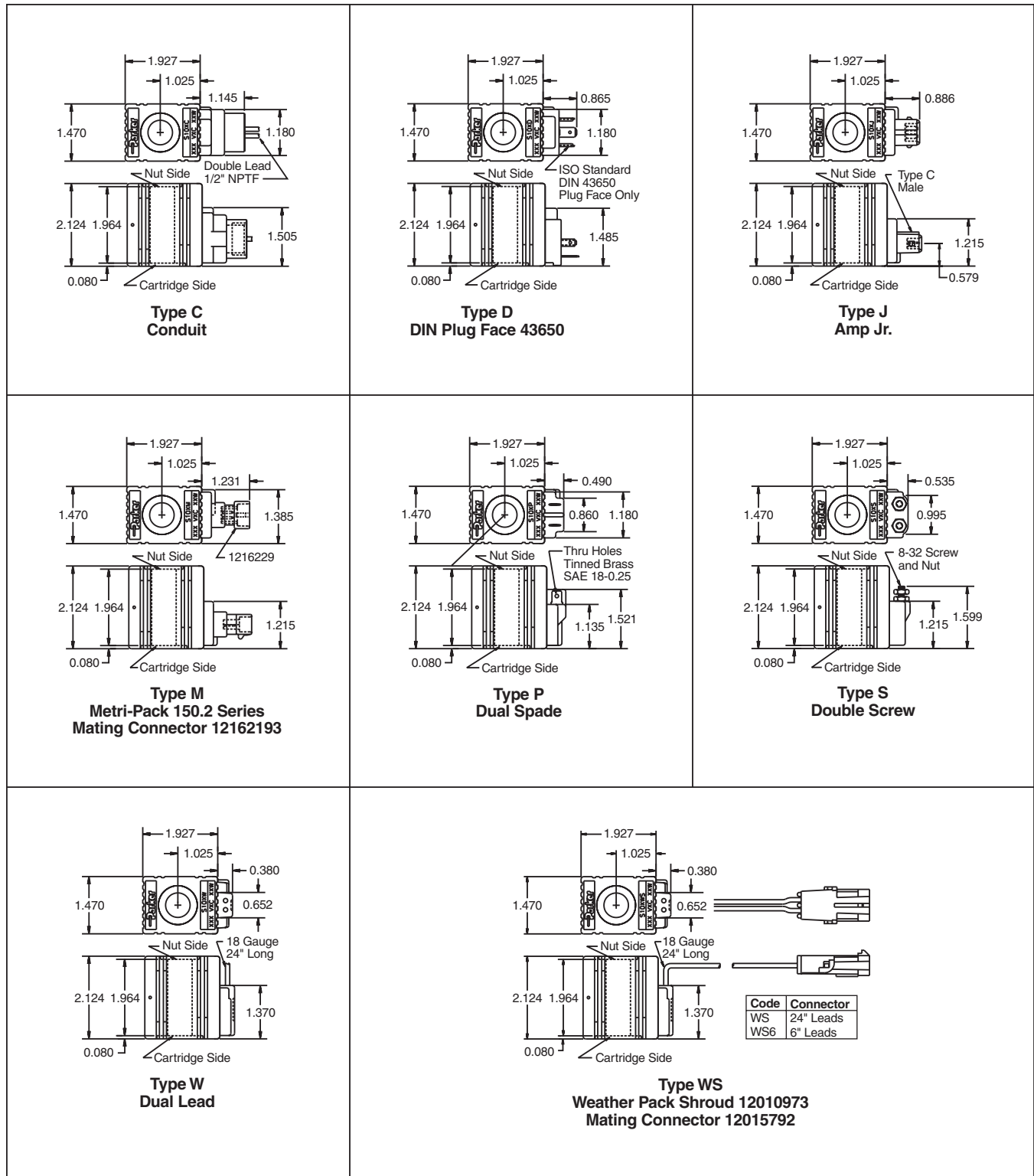

- CV** Check Valves
- SH** Shuttle Valves
- LM** Load/Motor Controls
- FC** Flow Controls
- PC** Pressure Controls
- LE** Logic Elements
- DC** Directional Controls
- MV** Manual Valves
- SV** Solenoid Valves
- PV** Proportional Valves
- CEI** Coils & Electronics
- BC** Bodies & Cavities
- TD** Technical Data

Technical Information

CV

Check Valves

SH

Shuttle Valves

LM

Load/Motor Controls

FC

Flow Controls

PC

Pressure Controls

LE

Logic Elements

DC

Directional Controls

MV

Manual Valves

SV

Solenoid Valves

PV

Proportional Valves

CE

Coils & Electronics

BC

Bodies & Cavities

TD

Technical Data

Features

- Compact one piece encapsulated design
- Minimal amperage draw
- Numerous terminals and voltages
- High watt design available for intermittent operation
- Heavy gauge color coded lead wire with built-in strain relief
- 180°C Class H wire standard
- 200°C Class N wire on high watt models

Specifications

|                                |  |
|--------------------------------|--|
| <b>Wattage</b>                 | 12 Watts — Standard - Black Coil<br>25 Watts — High Watt - Red Coil  |
| <b>Duty Rating</b>             | Continuous @ 100% voltage  |
| <b>Wire Class</b>              | Class H for all voltages 12 Watt<br>Class N for all voltages 25 Watt   |
| <b>A.C. Rectifier</b>          | Integral full wave bridge  |
| <b>Lead Wire</b>               | 18 gauge 24" long, 600 volt rating   |
| <b>Lead Wire Strain Relief</b> | 34 kg (75 lbs.) @ 21°C (70°F) &<br>18 kg (40 lbs.) @ 93°C (200°F)  |
| <b>Encapsulating Material</b>  | Glass filled nylon, resistant to moisture, caustic solutions, fungus, and temperatures from -40°C (-40°F) to 200°C (392°F) |

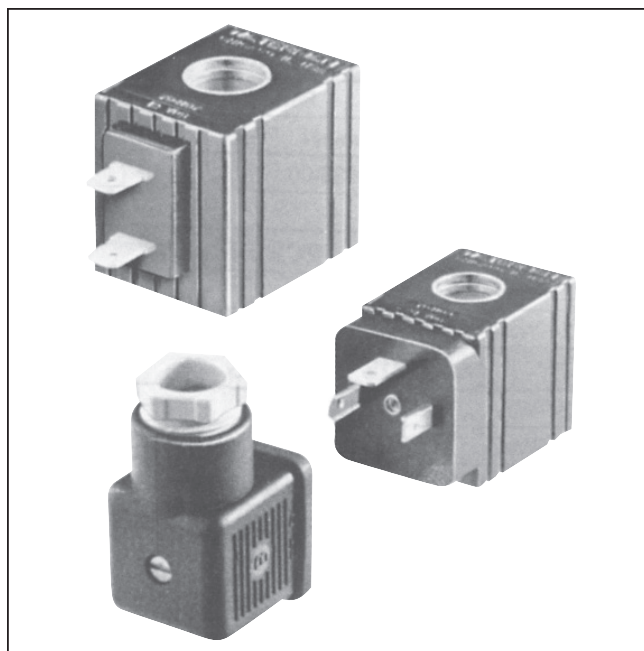

Symbol

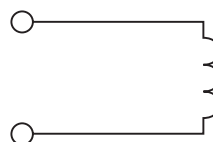

AC Coil Assembly

No inductive or capacitive loads can be installed between surge suppressor and rectified valves.

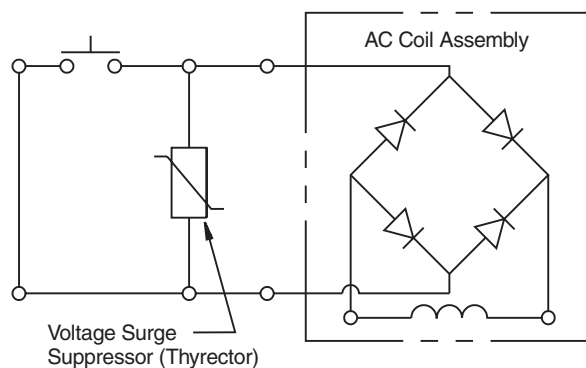

NOTE:

Parker A.C. Coils incorporate integrally molded full wave rectifiers which are rated for reverse voltage peaks of 1000 volts maximum. For voltage transients greater than 1000 volts P.I.V., Harris Thyrector V150LA10A or V150LA20A for 115 VAC and V250LA15A or V250LA40A for 200 VAC is recommended.

**Terminal Styles and Dimensions**

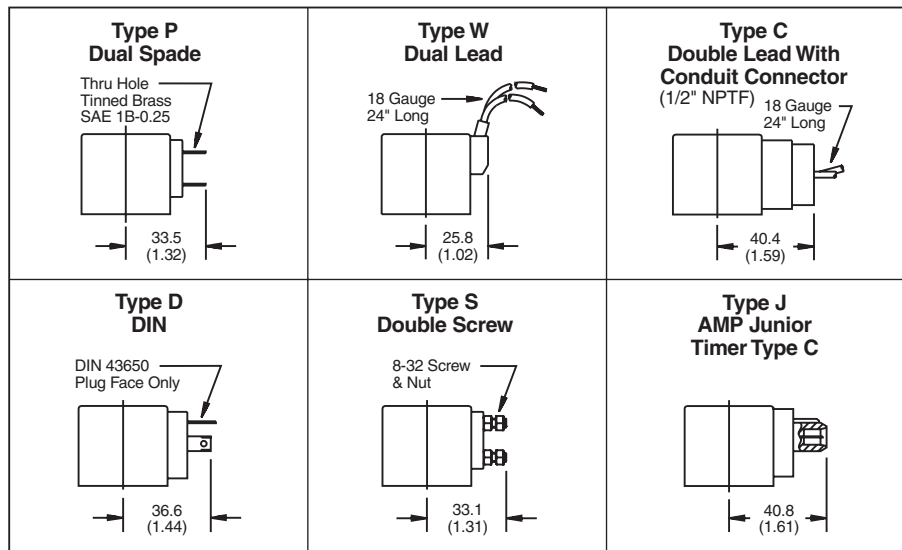
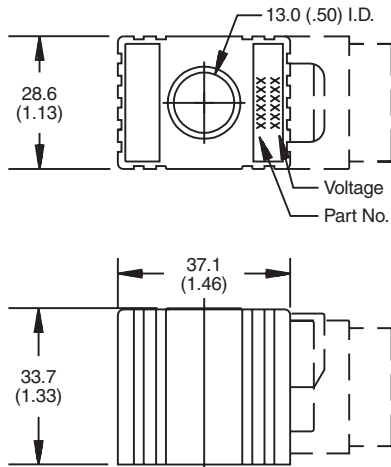

**NOTES:**

1. Coil to be installed with part number on nut side.
2. For additional terminals, voltages and wattages, consult factory for details.

**Coil Part Numbers**

| Voltage   | Watts | Type P<br>Double<br>Spade | Type W<br>Double<br>Lead | Type C<br>Conduit<br>Connector | Type D<br>DIN<br>Plug Face | Type S<br>Double<br>Screw | Amps† | Lead Wire<br>Color |
|-----------|-------|---------------------------|--------------------------|--------------------------------|----------------------------|---------------------------|-------|--------------------|
| **6 VDC   | 12    | 851007-006                | 851009-006               | 851003-006*                    | 851005-006*                | 851011-006                | 2.22  | Black              |
|           | 25    | 851008-006                | 851010-006               | 851004-006                     | 851006-006                 | 851012-006                | 3.90  |                    |
| **10 VDC  | 12    | 851007-010                | 851009-010               | 851003-010*                    | 851005-010*                | 851011-010                | 1.43  | Yellow             |
|           | 25    | 851008-010                | 851010-010               | 851004-010                     | 851006-010                 | 851012-010                | 2.48  |                    |
| 12 VDC    | 12    | 851007-012                | 851009-012               | 851003-012*                    | 851005-012*                | 851011-012                | 1.05  | Red                |
|           | 25    | 851008-012                | 851010-012               | 851004-012                     | 851006-012                 | 851012-012                | 1.94  |                    |
| **18 VDC  | 12    | 851007-018                | 851009-018               | 851003-018*                    | 851005-018*                | 851011-018                | 0.75  | Gray               |
|           | 25    | 851008-018                | 851010-018               | 851004-018                     | 851006-018                 | 851012-018                | 1.42  |                    |
| 24 VDC    | 12    | 851007-024                | 851009-024               | 851003-024*                    | 851005-024*                | 851011-024                | 0.52  | Blue               |
|           | 25    | 851008-024                | 851010-024               | 851004-024                     | 851006-024                 | 851012-024                | 1.17  |                    |
| **36 VDC  | 12    | 851007-036                | 851009-036               | 851003-036*                    | 851005-036*                | 851011-036                | 0.38  | Orange             |
|           | 25    | 851008-036                | 851010-036               | 851004-036                     | 851006-036                 | 851012-036                | 0.73  |                    |
| **48 VDC  | 12    | 851007-048                | 851009-048               | 851003-048*                    | 851005-048*                | 851011-048                | 0.26  | Green              |
|           | 25    | 851008-048                | 851010-048               | 851004-048                     | 851006-048                 | 851012-048                | 0.59  |                    |
| 120 VAC   | 12    |                           |                          | 851003-120                     | 851005-120                 |                           | 0.14  | Brown              |
|           | 25    |                           |                          | 851004-120                     | 851006-120                 |                           | 0.23  |                    |
| 230 VAC   | 12    |                           |                          | 851003-240                     | 851005-240                 |                           | 0.08  | White              |
|           | 25    |                           |                          | 851004-240                     | 851006-240                 |                           | 0.12  |                    |
| **440 VAC | 12    |                           |                          | 851003-480                     | 851005-480                 |                           | 0.04  | Violet             |
|           | 25    |                           |                          | 851004-480                     | 851006-480                 |                           | 0.07  |                    |

\*\*Consult Factory \*UL Listed

†Amperage draw @ 21°C (70°F)

- CV**  
Check Valves
- SH**  
Shuttle Valves
- LM**  
Load/Motor Controls
- FC**  
Flow Controls
- PC**  
Pressure Controls
- LE**  
Logic Elements
- DC**  
Directional Controls
- MV**  
Manual Valves
- SV**  
Solenoid Valves
- PV**  
Proportional Valves
- CE**  
Coils & Electronics
- BC**  
Bodies & Cavities
- TD**  
Technical Data

Technical Information

CV

Check Valves

SH

Shuttle Valves

LM

Load/Motor Controls

FC

Flow Controls

PC

Pressure Controls

LE

Logic Elements

DC

Directional Controls

MV

Manual Valves

SV

Solenoid Valves

PV

Proportional Valves

CE

Coils & Electronics

BC

Bodies & Cavities

TD

Technical Data

Features

- Compact one piece encapsulated design
- Minimal amperage draw
- Numerous terminals and voltages
- High watt design optional
- Heavy gauge color coded lead wire with built-in strain relief
- 180°C Class H wire standard
- 200°C Class N wire on high watt models

Specifications

|                                |  |
|--------------------------------|--|
| <b>Wattage</b>                 | 17 Watts — Standard - Black Coil<br>30 Watts — High Watt - Red Coil  |
| <b>Duty Rating</b>             | Continuous @ 100% voltage  |
| <b>Wire Class</b>              | Class H for all voltages 17 Watt<br>Class N for all voltages 30 Watt   |
| <b>A.C. Rectifier</b>          | Integral full wave bridge  |
| <b>Lead Wire</b>               | 18 gauge 24" long, 600 volt rating   |
| <b>Lead Wire Strain Relief</b> | 34 kg (75 lbs.) @ 21°C (70°F) &<br>18 kg (40 lbs.) @ 93°C (200°F)  |
| <b>Encapsulating Material</b>  | Glass filled nylon, resistant to moisture, caustic solutions, fungus, and temperatures from -40°C (-40°F) to 200°C (392°F) |

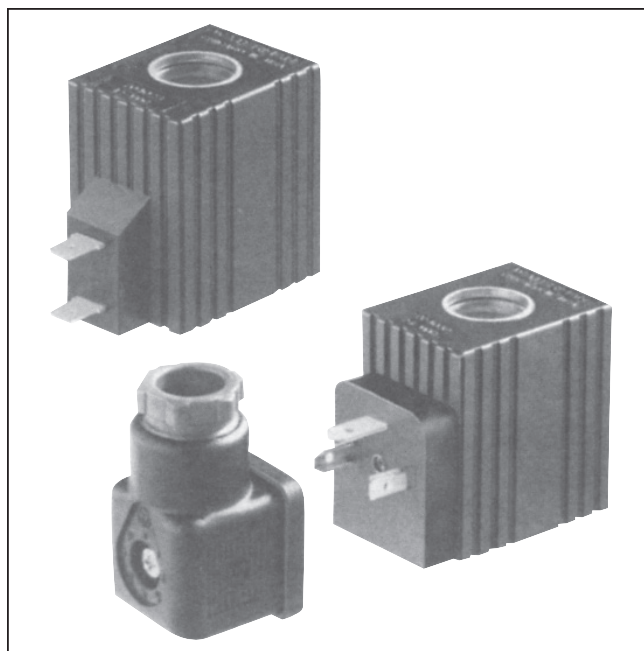

Symbol

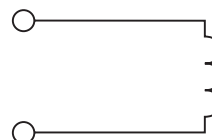

AC Coil Assembly

No inductive or capacitive loads can be installed between surge suppressor and rectified valves.

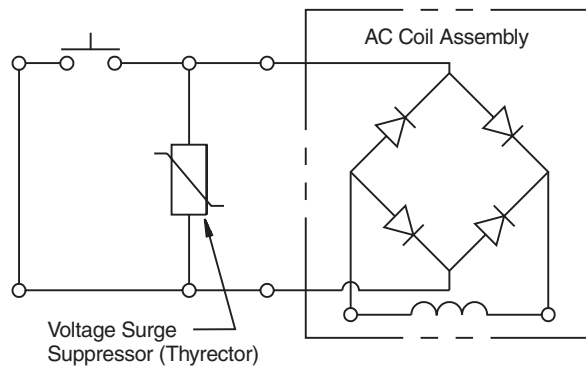

NOTE:

Parker A.C. Coils incorporate integrally molded full wave rectifiers which are rated for reverse voltage peaks of 1000 volts maximum. For voltage transients greater than 1000 volts P.I.V., Harris Thyrector V150LA10A or V150LA20A for 115 VAC and V250LA15A or V250LA40A for 200 VAC is recommended.

**Terminal Styles and Dimensions**

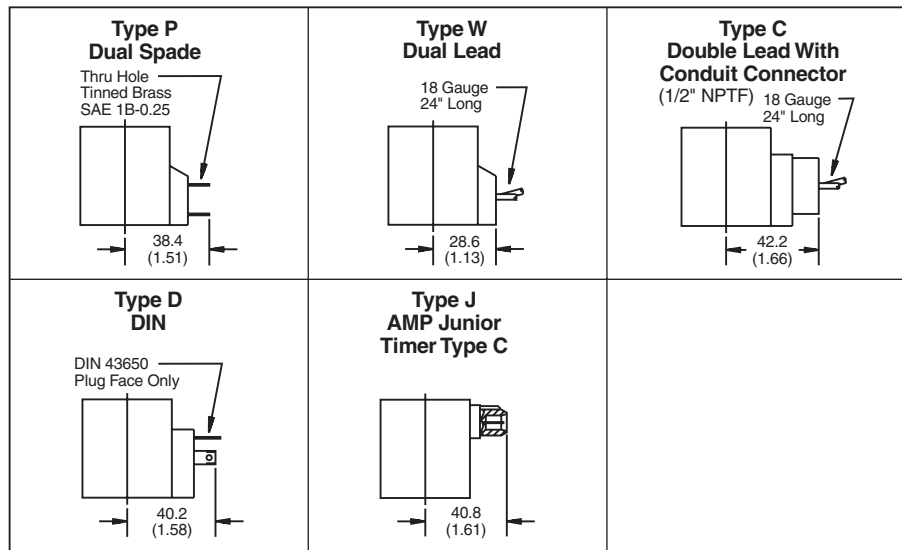
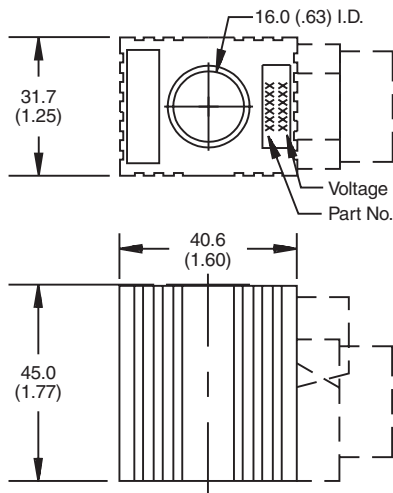

**NOTES:**

1. Coil to be installed with part number on nut side.
2. For additional terminals, voltages and wattages, consult factory for details.

**Coil Part Numbers**

| Voltage | Watts | Type P<br>Double<br>Spade | Type W<br>Double<br>Lead | Type C<br>Conduit<br>Connector | Type D<br>DIN<br>Plug Face | Amps* | Lead Wire<br>Color |
|---------|-------|---------------------------|--------------------------|--------------------------------|----------------------------|-------|--------------------|
| 6 VDC   | 17    | 851021-006                | 851023-006               | 851017-006                     | 851019-006                 | 2.43  | Black              |
|         | 30    | 851022-006                | 851024-006               | 851018-006                     | 851020-006                 | 4.84  |                    |
| 10 VDC  | 17    | 851021-010                | 851023-010               | 851017-010                     | 851019-010                 | 1.58  | Yellow             |
|         | 30    | 851022-010                | 851024-010               | 851018-010                     | 851020-010                 | 3.28  |                    |
| 12 VDC  | 17    | 851021-012                | 851023-012               | 851017-012                     | 851019-012                 | 1.44  | Red                |
|         | 30    | 851022-012                | 851024-012               | 851018-012                     | 851020-012                 | 2.30  |                    |
| 18 VDC  | 17    | 851021-018                | 851023-018               | 851017-018                     | 851019-018                 | 0.94  | Gray               |
|         | 30    | 851022-018                | 851024-018               | 851018-018                     | 851020-018                 | 1.86  |                    |
| 24 VDC  | 17    | 851021-024                | 851023-024               | 851017-024                     | 851019-024                 | 0.72  | Blue               |
|         | 30    | 851022-024                | 851024-024               | 851018-024                     | 851020-024                 | 1.20  |                    |
| 36 VDC  | 17    | 851021-036                | 851023-036               | 851017-036                     | 851019-036                 | 0.43  | Orange             |
|         | 30    | 851022-036                | 851024-036               | 851018-036                     | 851020-036                 | 0.88  |                    |
| 48 VDC  | 17    | 851021-048                | 851023-048               | 851017-048                     | 851019-048                 | 0.30  | Green              |
|         | 30    | 851022-048                | 851024-048               | 851018-048                     | 851020-048                 | 0.58  |                    |
| 120 VAC | 17    |                           |                          | 851017-120                     | 851019-120                 | 0.15  | Brown              |
|         | 30    |                           |                          | 851018-120                     | 851020-120                 | 0.24  |                    |
| 230 VAC | 17    |                           |                          | 851017-240                     | 851019-240                 | 0.08  | White              |
|         | 30    |                           |                          | 851018-240                     | 851020-240                 | 0.13  |                    |
| 440 VAC | 17    |                           |                          | 851017-480                     | 851019-480                 | 0.04  | Violet             |
|         | 30    |                           |                          | 851018-480                     | 851020-480                 | 0.07  |                    |

\*Amperage draw @ 21°C (70°F)

**CV** Check Valves  
**SH** Shuttle Valves  
**LM** Load/Motor Controls  
**FC** Flow Controls  
**PC** Pressure Controls  
**LE** Logic Elements  
**DC** Directional Controls  
**MV** Manual Valves  
**SV** Solenoid Valves  
**PV** Proportional Valves  
**CE** Coils & Electronics  
**BC** Bodies & Cavities  
**TD** Technical Data

**Features**

- Compact one piece encapsulated design
- Numerous terminals and voltages
- Heavy gauge color coded lead wire with built-in strain relief
- 200°C Class N wire standard
- U.L. recognized on most DC coils (consult factory)

**Specifications**

|                                |  |
|--------------------------------|--|
| <b>Wattage</b>                 | 42 Watts — Standard<br>30 Watts — Low Watt   |
| <b>Duty Rating</b>             | Continuous @ 100% voltage  |
| <b>Wire Class</b>              | Class N for all voltages   |
| <b>Lead Wire</b>               | 18 gauge 24" long, 600 volt rating   |
| <b>Lead Wire Strain Relief</b> | 34 kg (75 lbs.) @ 21°C (70°F) &<br>18 kg (40 lbs.) @ 93°C (200°F)  |
| <b>Encapsulating Material</b>  | Glass filled nylon, resistant to moisture, caustic solutions, fungus, and temperatures from -40°C (-40°F) to 200°C (392°F) |
| <b>Color</b>                   | Black  |

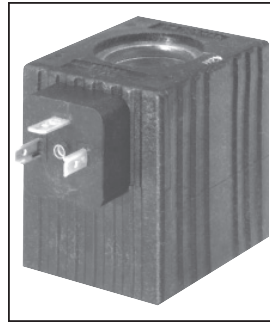

**AC Coil Assembly**

No inductive or capacitive loads can be installed between surge suppressor and rectified valves.

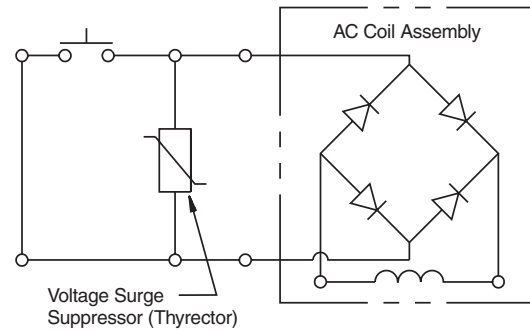

**Terminal Styles and Dimensions**

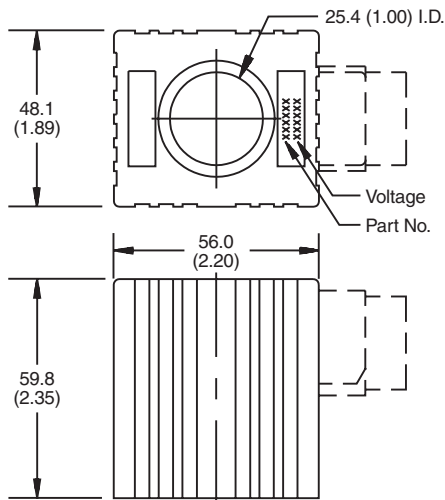

**NOTES:**

1. Coil to be installed with part number on nut side.
2. For additional terminals, voltages and wattages, consult factory for details.

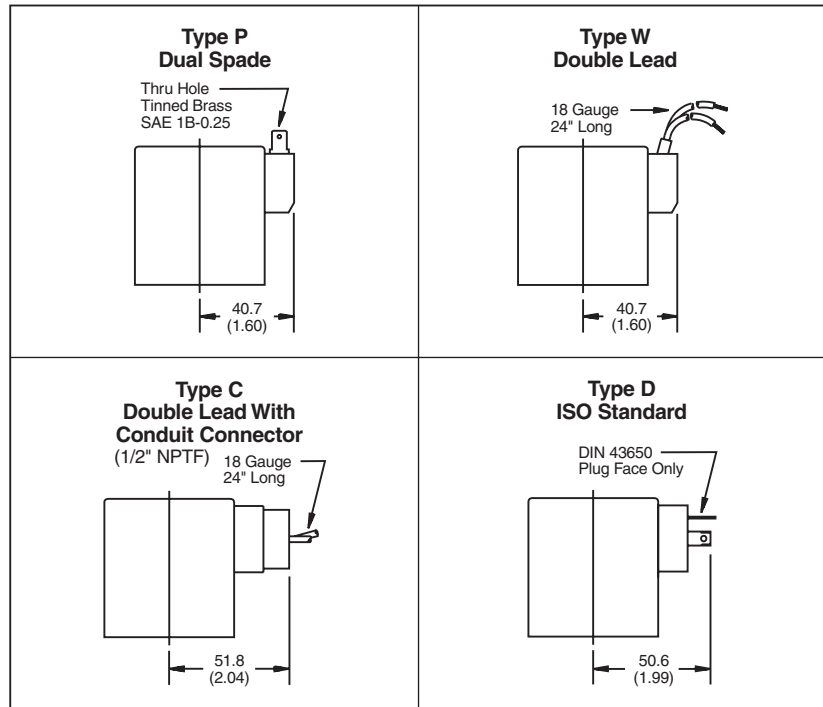

**Coil Part Numbers**

| Wattage  | Voltage | Type P Double Spade | Type W Double Lead | Type D ISO STANDARD | Amps | Lead Wire Color |
|----------|---------|---------------------|--------------------|---------------------|------|-----------------|
| 42 Watts | 12 VDC  | 851060-012*         | 851062-012*        | 851058-012*         | 3.53 | Red             |
| 42 Watts | 24 VDC  | 851060-024*         | 851062-024*        | 851058-024*         | 1.79 | Blue            |
| 30 Watts | 12 VDC  | 853496-012          | 853497-012         | 853495-012          | 2.50 | Red             |
| 30 Watts | 24 VDC  | 853496-024          | 853497-024         | 853495-024          | 1.25 | Blue            |

\*UL Listed