

Pressure relief valve 1915

for heating installations



Field of application

The pressure relief valve type 1915 is designed to protect heating installations against excess pressure. The connection size has to be determined in accordance with the heating capacity of the heat-generating device to be protected. The highest admissible operating pressure of the installation and the resulting maximum opening pressure of the pressure relief valve shall be observed. For systems with a heating capacity exceeding the values in the table, observe the following rule: 3 pressure relief valves per heat-generating device are admissible.

The pressure relief valve type 1915 can be used as safety component in compliance with the Pressure Equipment Directive 97/23/EG for directly or indirectly heated pressure tanks designed to generate steam or hot water according to Art. 3 section 1.2 up to category IV.

Design

The operational parts in the pressure relief valve type 1915 are protected against direct contact with the medium (protection against corrosion). The pressure relief valve can be lifted by means of the rotatable handle. Cleaning the seat and the seal after having removed the head part does not change the opening pressure.



Pressure relief valve 1915

Materials

The body is made of a high-quality low-lead brass alloy (DN 15 - DN 32) or a dezincification resistant low-lead gunmetal alloy (DN 40 - DN 50); the spring cap, the diaphragm and other internal parts are made of heat

and ageing resistant elastomeric synthetic material and the spring of corrosion protected spring steel wire.

Installation

Install the pressure relief valve type 1915 vertically with the inlet connections facing downwards. The length of the supply pipe shall not exceed 1 m, bends are not admissible and its nominal size must be the size of the valve inlet. Position the valve at the highest point of the heat-generating device or in the radiator supply line close to the heat-generating device. There shall be no isolating valves, strainers or similar devices in the supply pipe.

The diameter of the relief pipe must be at least equal to the nominal size of the valve outlet. The relief pipe has to be installed with continuous incline. It can maximally

include 2 bends and have a length of 2 meters. When a length exceeding 2 m is necessary, the pipe must be one size larger. Caution: more than 3 bends and a length exceeding 4 meters are not admissible. The outlet of the relief pipe must be free from obstruction, controllable and positioned in such a way that persons are not endangered. When the relief pipe ends over a tundish, it is indispensable that its drain pipe has at least the double cross section of the valve inlet. Free access to the pressure relief valve must be provided; it has to be located in the boiler room.

Thoroughly rinse the pipe prior to installation. Install the pressure relief valve under consideration of the flow direction

(see arrow on the body) in compliance with the instructions.

Technical data

Operating temperature:	-10 °C to max. 120 °C
Opening pressure:	1.5 - 5 bar
Standard setting:	2.5 and 3 bar
Mounting position:	Main axis vertical, inlet connections facing downwards
Component approval number:	TÜV-SV-02-525-H-P-p
Fluids:	water; neutral non-adhesive fluids;
Serial number:	1915...

Maintenance

The correct function of the pressure relief valve should be checked by qualified personnel at initial operation and then once a year: turn the lifting handle in the direction of the arrow until you hear a click. Afterwards, the valve has to be closed tight. Should the valve drip constantly, it is very likely that impurities have built up in the seat. To clean the valve seat and seal, unscrew the head part. The seat seal is

exchangeable for valves with a connection size of DN 40 or more. After cleaning, refit the head part; the opening pressure remains unchanged after this operation. Pressure relief valves DN 15 with a damaged valve seat can be repaired by means of the exchange cartridge 1916, which makes them equivalent to a new valve.

Pressure relief valve 1915

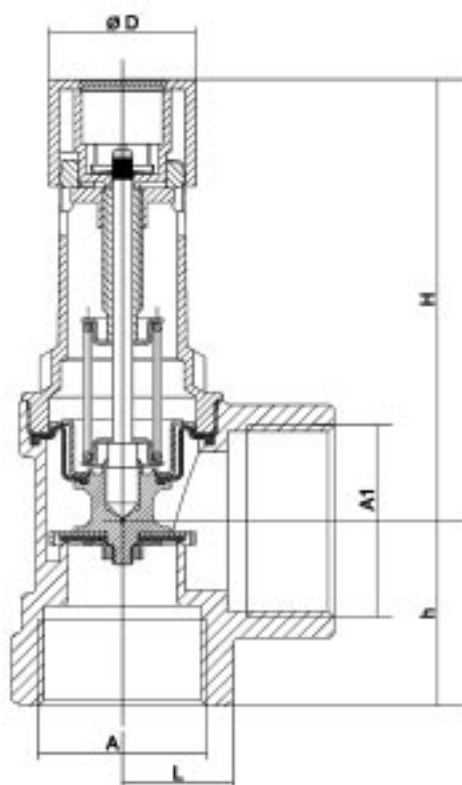

Nominal size		DN 15	DN 20	DN 25	DN 32	DN 40	DN 50
Dimensions	A	G ½	G ¾	G 1	G 1 ¼	G 1 ½	G 2
	d (mm)	15	22	28	35	42	54
	A 1	¾	1	1 ¼	1 ½	2	2 ½
	L (mm)	35	38	47	53	70	75
	H (mm)	46	48	79	110	136	195
	h (mm)	28	34	40	46	55	66
	D (mm)	31	31	49	51	75	75
	Opening pressure (bar)	Max. heating capacity of the heat-generating device (kw)					
	1,5	36	72	144	252	433	650
	2	43	86	172	302	518	778
	2,5	50	100	200	350	600	900
	3	56	112	224	395	678	1017
	4	70	140	280	490	840	1260
	5	84	168	336	588	1008	1512

Pressure relief valve 1915

Components / Order numbers

①
Head part

②
Body

③
Exchange cartridge 1916
DN 15 2.5 bar: 1916.15.000
DN 15 3.0 bar: 1916.15.001

