

Both 65 mm and 150 mm scales, borosilicate glass tube models feature all stainless steel frame and horizontal connections at a less expensive price than competitive products. Valve optional.



DESCRIPTION

Metering Tube

Borosilicate Kinglass

Internal Components

316L Stainless Steel, Black Glass, Sapphire, Carboloy, Tantalum

Inlet/Outlet Fittings

1/8" and 1/4" FNPT, Horizontal Control Valve optional

Fitting Material

316L Stainless Steel
Optional: PVC, PVDF, Hastelloy®

Elastomers

Standard: Viton®
Optional: Buna N, EPR, Kalrez®

PERFORMANCE

Capacities

0.72 to 1,800 cc/min — Water
66 to 70,000 cc/min — Air

Scale

65 mm, 150 mm
Direct reading, detachable

Accuracy

± 6% of Full Scale Flow, 65 mm
± 4% of Full Scale Flow, 150 mm

Turndown

10:1 to 12.5:1 unless otherwise indicated

Repeatability

1%

Max Temperature

250° F (121° C) Gases
200° F (93° C) Liquids

Max Pressure

316L SS Fittings — 200 psig
PVC Fittings — 130 psig
PVDF Fittings — 150 psig

Ambient Temperature

33° F to 125° F (1° C to 52° C)

OPTIONS

Alarm

Fiber-Optic or Inductive Ring Sensor
(see page 19)

Certified Calibrations

Conform to ISA RP 16.6

Scales

Can be produced in any volumetric unit

SPECIFICATIONS:

Tube Number	Float Material	65MM Scale Flow Ranges					
		Air (STP)			Water (70° F)		
		CC/MIN	SCFH	SLPH	CC/MIN	GPH	LPH
1-02-G-021	Glass	66	.14	4.0	0.72	.011	.042
	Sapphire	105	.22	6.2	1.3	.021	.078
	Stainless Steel	200	.42	12.0	3.3	.052	.190
	Carboloy	340	.70	20.0	7.0	.110	.420
	Tantalum	350	.74	21.0	7.8	.125	.460
1-03-G-041	Glass	76	.16	4.6	1.15	.018	.068
	Sapphire	120	.25	7.2	2.10	.032	.125
	Stainless Steel	230	.50	14.0	4.20	.068	.260
	Carboloy	400	.85	24.0	9.00	.145	.560
	Tantalum	440	.90	26.0	10.00	.165	.620
1-08-G-061	Glass	525	1.1	31	9.0	.14	.54
	Sapphire	700	1.5	42	15.5	.24	.95
	Stainless Steel	1130	2.4	68	29.0	.46	1.70
	Carboloy	1600	3.4	95	46.0	.72	2.80
	Tantalum	1700	3.6	100	50.0	.78	3.00
1-23-G-081	Glass	2000	4.2	120	44	.70	2.6
	Sapphire	2600	5.4	150	68	1.05	4.0
	Stainless Steel	3800	8.2	230	110	1.70	6.6
	Carboloy	5600	12.0	340	170	2.70	10.5
	Tantalum	6000	13.0	360	180	2.90	11.0
2-14-G-021	Glass	6800	14.5	400	160	2.6	9.5
	Sapphire	9200	19.5	540	240	3.8	14.5
	Stainless Steel	13000	28.0	800	400	6.4	24.0
	Carboloy	19000	40.0	1100	600	9.5	36.0
	Tantalum	20000	42.0	1200	640	10.0	38.0
2-34-G-041	Glass	19000	40.0	1150	520	8.25	31.0
	Sapphire	25000	52.0	1500	740	11.50	44.0
	Stainless Steel	42500	90.0	2550	1200	19.00	72.0
	Carboloy	60000	125.0	3600	1700	27.00	105.0
	Tantalum	70000	145.0	4200	1800	29.00	110.0

Tube Number	Float Material	150 MM Scale Flow Ranges					
		Air (STP)			Water (70° F)		
		CC/MIN	SCFH	SLPH	CC/MIN	GPH	LPH
1-03-G-022	Glass	54	.114	3.2	.56	.0088	.033
	Sapphire	82	.175	4.9	1.04	.0160	.062
	Stainless Steel	160	.340	9.8	2.25	.0350	.135
	Carboloy	280	.580	16.5	5.00	.0780	.300
	Tantalum	300	.620	17.5	5.20	.0840	.320
1-04-G-042	Glass	106	.225	6.4	1.24	.0195	.074
	Sapphire	165	.35	10.0	2.35	.0380	.145
	Stainless Steel	320	.68	19.0	5.60	.0900	.340
	Carboloy	540	1.14	32.0	12.4	.1950	.740
	Tantalum	580	1.24	35.0	13.5	.2100	.820
1-07-G-062	Glass	350	.74	21.0	4.7	.074	.28
	Sapphire	500	1.06	30.0	10.0	.160	.60
	Stainless Steel	820	1.75	50.0	20.5	.330	1.25
	Carboloy	1250	2.60	76.0	34.0	.540	2.05
	Tantalum	1350	2.90	80.0	36.0	.560	2.15
1-11-G-082	Glass	850	1.8	50.0	16.5	.26	1.0
	Sapphire	1100	2.3	66.0	27.0	.42	1.6
	Stainless Steel	1600	3.4	100.0	46.0	.72	2.7
	Carboloy	2300	4.9	140.0	72.0	1.15	4.4
	Tantalum	2450	5.2	155.0	80.0	1.25	4.8
1-27-G-102	Glass	2150	4.6	130.0	52	.84	3.1
	Sapphire	2800	6.0	170.0	78	1.24	4.7
	Stainless Steel	4400	9.2	260.0	130	2.05	7.8
	Carboloy	6200	13.5	380.0	205	3.20	12.5
	Tantalum	6750	14.0	400.0	210	3.30	12.5
2-09-G-002	Glass	3800	8.2	230.0	86	1.35	5.2
	Sapphire	5000	10.6	300.0	130	2.05	7.8
	Stainless Steel	7500	16.0	450.0	220	3.40	13.0
	Carboloy	10600	22.5	640.0	330	5.20	20.0
	Tantalum	11500	24.0	680.0	360	5.60	21.5
2-17-G-022	Glass	9000	19.0	540.0	215	3.40	13.0
	Sapphire	11400	24.5	700.0	320	5.00	19.0
	Stainless Steel	17000	36.0	1000.0	520	8.20	31.0
	Carboloy	24000	50.0	1450.0	760	12.2	46.0
	Tantalum	25000	54.0	1500.0	820	13.0	49.0
2-32-G-042	Glass	20500	43.0	1220.0	470	7.5	28.0
	Sapphire	26000	56.0	1550.0	700	11.0	42.0
	Stainless Steel	38000	82.0	2300.0	1120	18.0	68.0
	Carboloy	54000	116.0	3300.0	1650	26.0	100.0
	Tantalum	60000	125.0	3500.0	1750	28.0	106.0

DIMENSIONS

Detail Letter	Scale length	
	65mm	150mm
A	1.50	1.50
B	6.05	10.25
C	1.56	1.56
D	4.53	8.826
E	0.50	.050
F	2.90	2.90
G	0.73	0.73

DIMENSION DIAGRAM

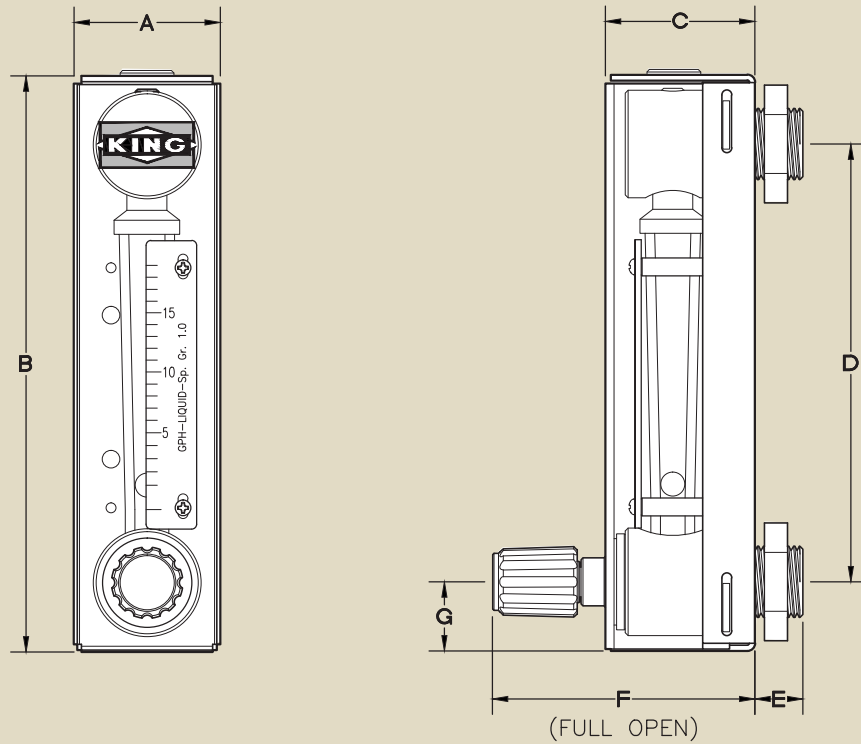

ORDERING:

Use the following guide to determine the specific product number you require.

Meter Series	Tube Number	Float Material	Fitting Material	O-ring Material	Scale	Valve Option	Optional Alarm Switch
7 4 C	See Specifications Table	Glass - 1 Sapphire - 2	316L SS - 1/8" FNPT - 1 316L SS - 1/4" FNPT - 2	EPR - 1 Buna-N - 2	Millimeter - 1 GPH Water@70°F - 2	316L SS - Inlet - 1 316L SS - Outlet - 2	Without Alarm - 0
		316 SS - 3	PVC - 1/4" FNPT - 3	Viton® - 3	LPH Water@70°F - 3	No Valve - 3	Fiber-Optic NPN (Proximity) - 1 Fiber-Optic PNP (Proximity) - 2
		Carboloy - 4	PVC - 1/8" FNPT - 4	Kalrez® No Valve - 4	CC/MIN Water@STP - 4	PVC - Inlet - 4	Inductive Ring Sensor (Proximity) - 3
		Tantalum - 5	PVDF - 1/4" FNPT - 5 PVDF - 1/8" FNPT - 6	Kalrez® Valve - 5	SCFH Air@STP - 5 SLPH Air@STP - 6	PVC - Outlet - 5 PVDF - Inlet - 6	Inductive Ring Sensor (Latching) - 4
			Hastelloy® C - 1/4" FNPT - 7 Hastelloy® C - 1/8" FNPT - 8		SCC/MIN Air@STP - 7 Non standard - 8	PVDF - Outlet - 7 Hastelloy® C - Inlet - 8 Hastelloy® C - Outlet - 9	

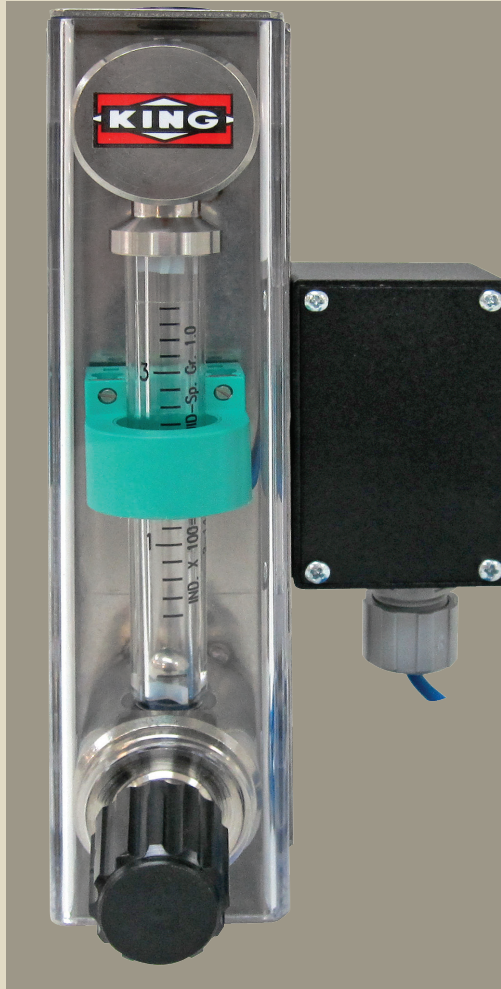

Inductive Ring Sensor

ALARM OPTIONS: 7430

Inductive Ring Sensor

7400 Series flowmeters with metallic floats can be ordered with an inductive ring sensor that is able to detect a predetermined rate of flow.

Inductive ring sensors are 2-wire, DC, low current devices and are designed to be used with a remote intrinsic safety barrier /switch isolator. Sensors are available as either proximity or latching devices. The sensor threaded on the screw can be positioned to trigger at any point on the scale. It is able to detect the metal float (see table below) by producing and electromagnetic field that senses the float within its sensing zone.

The inductive sensor connects to a barrier/switch isolator which powers the sensor and provides the desired switching option. Barrier/switch isolators are available with 220VAC, 110VAC or 24VDC supply voltage requirements, contain single pole double throw (SPDT) relays, and are DIN rail mountable. See barrier/switch isolator specifications for electrical connections and further details.

Note: We can supply switch isolator/barriers upon request. User power supply voltage must be provided.

Electrical Specifications:

Type: Inductive Proximity or Latching

Supply Voltage: 5-25V DC (Switch Isolator)

Output: NAMUR

Output Load Current:

<=1 mA – Float Present

>= 3 mA (15 mA max) – Float Absent

Switching Frequency: 2 kHz

Housing Rating: IP67

Wiring: PVC Covered, 2 Conductor, 26 AWG, 6.5 Feet Long, Brown (+), Blue (-)

Pepperl & Fuchs Ring Sensor

Approvals:

UL: General Purpose

FM: Intrinsically Safe

CSA: Intrinsically Safe

CENELEC: Intrinsically Safe

Electrical Connections: See barrier/switch isolator specifications for details.

Fiber Optic Sensor

The fiber optic alarm sensor is an available option for all 7400 Series flowmeters. The sensor is used to detect a predetermined rate of flow. The sensor can interface directly to a Programmable Logic Controller (PLC) or when connected to a separate relay can trigger a local or remote alarm.

The fiber optic sensor is mounted in a junction box attached to the side of the flowmeter. The sensor uses a pair of plastic transparent cables, an emitter and receiver, to transmit the light generated by the sensor. Each cable is terminated in the housing shown below. The housing is threaded on a screw and can be positioned at any point on the scale.

Electrical Specifications:

Supply Voltage: 10-30 VDC

Supply Current: 25 mA

Output: NPN Sinking, N.O. & N.C.
PNP Sourcing, N.O. & N.C.

Output Rating: 150 mA Max Total Load

Output Response Time: 1ms

Off State Leakage Current:

1 MICOAMP @ 30 VDC

Output Saturation Voltage:

< 1 V at 10 mA DC

< 1.5 V at 150 mA DC

Repeatability: 0.25 ms

Housing Rating: IP67; NEMA 6

Operating Temperature: -5° to +131° F

Operating Temperature Limits:

0°C to +40°C (1/8 Inch Float)

Operating Temperature Limits:

0°C to +70°C (1/4 Inch Float)

Part Number	Type	Float Size	Float Material
SE7410	Proximity	1/8"	SS, CB
SE7415	Proximity	1/4"	SS, CB
SE7410B	Latching	1/8"	SS, CB
SE7415B	Latching	1/4"	SS, CB