

Engineering Data
HFUS-2UH/2SO/2SH Units



Harmonic
Drive AG



...just move it!

Contents

1.	General	03
1.1	Description of Safety Alert Symbols	04
1.2	Disclaimer and Copyright	04
2.	Safety and Installation Instructions	05
2.1	Hazards	05
2.2	Intended Purpose	06
2.3	Non Intended Purpose.....	06
2.4	Declaration of Conformity.....	07
3.	Technical Description	08
3.1	Product Description	08
3.2	Ordering Code	09
3.3	Technical Data.....	10
3.3.1	General Technical Data.....	10
3.3.2	Dimensions.....	11
3.3.3	Minimum Housing Dimensions HFUS-2SO and HFUS-2SH	20
3.3.4	Accuracy.....	20
3.3.5	Torsional Stiffness	20
3.3.6	Bearings.....	21
3.3.7	Housing Materials and Surfaces	24
4.	Actuator Selection.....	25
4.1	Selecting Harmonic Drive® Gears.....	27
4.1.1	Torque Based Dimensioning.....	28
4.1.2	Life of the Wave Generator Bearing.....	30
4.1.3	Stiffness Based Dimensioning	31
4.2	Calculation of the Torsion Angle.....	33
4.3	Accuracy of the Oldham Coupling HFUS-2SO	33
4.4	Efficiency Versus Load	34
4.4.1	Efficiency Calculations HFUS-2SO and HFUS-2SH Units.....	34
4.4.2	Efficiency Calculations HFUS-2UH Units	35
4.4.3	Efficiency Tables.....	36
4.5	No Load Starting, Back Driving and Running Torque	39
4.5.1	No Load Running Torque	39
4.5.2	No Load Starting Torque.....	41
4.5.3	No Load Back Driving Torque.....	42
4.6	Continuous Operation Hollow Shaft Units HFUS-2UH.....	43
4.7	Output Bearing Operating Life	44
4.7.1	Output Bearing at Oscillating Motion	46
4.8	Permissible Static Tilting Moment.....	47
4.9	Angle of Inclination	47
4.10	Lubrication	48
4.10.1	Grease Lubrication	48
4.10.2	Oil Lubrication	50
4.11	Axial Forces at the Wave Generator HFUS-2SO and HFUS-2SH.....	51
5.	Installation and Operation	52
5.1	Transport and Storage.....	52
5.2	Gear Condition at Delivery.....	52
5.3	Assembly Information.....	52
5.4	Recommended Tolerances for Assembly HFUS-2SO and HFUS-2SH.....	53
5.5	Lubrication.....	54
5.5.1	Grease Lubrication HFUS-2SO and HFUS-2SH.....	54
5.5.2	Amount of Grease HFUS-2SO and HFUS-2SH	54
5.5.3	Additional Grease Package	55
5.5.4	Grease Change.....	55

5.5.5	Oil Lubrication	56
5.6	Assembly.....	56
5.7	Mounting.....	57
5.7.1	Motor Assembly HFUS-250	58
5.7.2	Wave Generator Components HFUS-250.....	59
5.7.3	Mounting the Wave Generator (WG) to the Motor Shaft.....	59
5.7.4	Check before Assembly of the Wave Generator (WG)	60
5.7.5	Assembly of the Wave Generator (WG) into the Flexspline (FS)	60
5.7.6	Assembly Control.....	60
5.7.7	Assembly of the Output Flange.....	61
5.7.8	Assembly of the Housing Flange	61
5.7.9	Installation of the Input Shaft HFUS-2UH und HFUS-2SH	61
6.	Glossary.....	62
6.1	Technical Data.....	62
6.2	Labelling, Guidelines and Regulations	68

1. General

About this documentation

This document contains safety instructions, technical data and operation rules for products of Harmonic Drive AG. The documentation is aimed at planners, project engineers, commissioning engineers and machine manufacturers, offering support during selection and calculation of the servo actuators, servo motors and accessories.

Rules for storage







Please keep this document for the entire life of the product, up to its disposal. Please hand over the documentation when re-selling the product.

Third-party systems

Documentation for parts supplied by third party suppliers, associated with Harmonic Drive® components, is not included in our standard documentation and should be requested directly from the manufacturers.

Before commissioning products from Harmonic Drive AG with servo drives, we advise you to obtain the relevant documents for each device.

1.1 Description of Safety Alert Symbols

Symbol	Meaning
	Indicates an imminent hazardous situation. If this is not avoided, death or serious injury could occur.
	Indicates a possible hazard. Care should be taken or death or serious injury may result.
	Indicates a possible hazard. Care should be taken or slight or minor injury may result.
	Describes a possibly harmful situation. Care should be taken to avoid damage to the system and surroundings.
	This is not a safety symbol. This symbol indicates important information.
	Warning of a general hazard. The type of hazard is determined by the specific warning text.
	Warning of dangerous electrical voltage and its effects.
	Beware of hot surfaces.
	Beware of suspended loads.
	Precautions when handling electrostatic sensitive components.

1.2 Disclaimer and Copyright

The contents, images and graphics contained in this document are protected by copyright. In addition to the copyright, logos, fonts, company and product names can also be protected by brand law or trademark law. The use of text, extracts or graphics requires the permission of the publisher or rights holder.

We have checked the contents of this document. Since errors cannot be ruled out entirely, we do not accept liability for mistakes which may have occurred. Notification of any mistake or suggestions for improvements will be gratefully received and any necessary correction will be included in subsequent editions.

2. Safety and Installation Instructions

Please take note of the information and instructions in this document. Specially designed models may differ in technical detail. If in doubt, we strongly recommend that you contact the manufacturer, giving the type designation and serial number for clarification.

2.1 Hazards



DANGER

Electric products have dangerous live and rotating parts. All work during connection, operation, repair and disposal must be carried out by qualified personnel as described in the standards EN50110-1 and IEC 60364! Before starting any work, and especially before opening covers, the actuator must be properly isolated. In addition to the main circuits, the user also has to pay attention to any auxiliary circuits.

Observing the five safety rules:

- Disconnect mains
- Prevent reconnection
- Test for absence of harmful voltages
- Ground and short circuit
- Cover or close off nearby live parts

The measures taken above must only be withdrawn when the work has been completed and the device is fully assembled. Improper handling can cause damage to persons and property. The respective national, local and factory specific regulations must be adhered to.



DANGER

Electric, magnetic and electromagnetic fields are dangerous, in particular for persons with pacemakers, implants or similar. Vulnerable groups must not be in the immediate vicinity of the products themselves.



DANGER

Built-in holding brakes alone are not functionally safe. Particularly with unsupported vertical axes, the functional safety and security can only be achieved with additional, external mechanical brakes.



WARNING

The successful and safe operation of gears, products requires proper transport, storage and assembly as well as correct operation and maintenance.



ATTENTION

The surface temperature of gears, motors and actuators can exceed 55 degrees Celsius. The hot surfaces should not be touched.



ADVICE

Movement and lifting of products with a mass > 20 Kg should only be carried out with suitable lifting gear.

ADVICE

Cables must not come into direct contact with hot surfaces.

INFORMATION

Special versions of drive systems and motors may have differing specifications. Please consider all data sheet, catalogues and offers etc. sent concerning these special versions.

2.2 Intended Purpose

The Harmonic Drive® products are intended for industrial or commercial applications. They comply with the relevant parts of the harmonised EN 60034 standards series.

Typical areas of application are robotics and handling, machine tools, packaging and food machines and similar machines.

The products may only be operated within the operating ranges and environmental conditions shown in the documentation (altitude, degree of protection, temperature range etc).

Before plant and machinery which have Harmonic Drive® products built into them are commissioned, the compliance must be established with the Machinery Directive, Low Voltage Directive and EMC guidelines.

Plant and machinery with inverter driven motors must satisfy the protection requirements in the EMC guidelines. It is the responsibility of the installer to ensure that installation is undertaken correctly.

Signal and power lines must be shielded. The EMC instructions from the inverter manufacturer must be observed in order that installation meets the EMC regulations.

2.3 Non Intended Purpose

The use of products outside the areas of application mentioned above or, inter alia, other than in the operating areas or environmental conditions described in the documentation is considered as non-intended purpose.

ADVICE

The following areas of application are, inter alia, those considered as non-intended purpose:

- Aerospace
- Areas at risk of explosion
- Machines specially constructed or used for a nuclear purpose whose breakdown might lead to the emission of radio-activity
- Vacuum
- Machines for domestic use
- Medical equipment which comes into direct contact with the human body
- Machines or equipment for transporting or lifting people
- Special devices for use in annual markets or leisure parks

2.4 Declaration of Conformity

Harmonic Drive® gears are components for installation in machines as defined by the machine directive 89/392/EWG. Commissioning is prohibited until such time as the end product has been proved to conform to the provisions of this directive.

Essential health and safety requirements were considered in the design and manufacture of these gear component sets. This simplifies the implementation of the machinery directive by the end user for the machinery or the partly completed machinery. Commissioning of the machine or partly completed machine is prohibited until the final product conforms to the EC Machinery Directive.

3. Technical Description

3.1 Product Description

Compact with largest hollow shaft

HFUS Series Units are available in nine sizes with gear ratios of 30, 50, 80, 100, 120 and 160:1 offering repeatable peak torques from 9 to 1840 Nm.

The output bearing with high tilting rigidity enables the direct introduction of high payloads without further support and thus permits simple and space saving design installations.

The HFUS Series is available in three versions: the HFUS-2UH Unit is fully sealed with a large hollow shaft diameter to feed through supply lines, shafts or cables for further drive systems. The HFUS-2SO and HFUS-2SH Simplicity Units are very short and lightweight, consisting of a component set and the heavy duty output bearing. The absence of input and output flanges means maximum flexibility in design integration, the 2SO version being available with a standard Wave Generator and the 2SH version with hollow shaft.

All versions of the HFUS Series are available on request for ambient temperatures -40 to 90 ° C and with a wide range of special lubricants tailored for your application.

3.2 Ordering Code

Table 9.1

Series	Size	Ratio ¹⁾						Version	Special design	
		30	50	80	100	120	160			
HFUS	14	30	50	80	100			2UH 2SO 2SH	According to customer requirements	
	17	30	50	80	100	120				
	20	30	50	80	100	120	160			
	25	30	50	80	100	120	160			
	32	30	50	80	100	120	160			
	40		50	80	100	120	160			
	45		50	80	100	120	160			
	50		50	80	100	120	160			
	58		50	80	100	120	160			
Ordering code										
HFUS	25	100				2UH		SP		

¹⁾ The ratios shown here are for a standard driving configuration with the circular spline fixed, the Wave Generator used for the input and the Flexspline attached to the output. Other configurations are possible. Please consult chapter 4 "Ratio".

Table 9.2

Version	
Ordering code	Description
2UH	Unit for motor assembly
2SO	Unit with hollow shaft
2SH	Unit with solid input shaft

Clarification of the technical data can be found in the Glossary

3.3 Technical Data

3.3.1 General Technical Data

Table 10.1

	Unit	HFUS-14			
		30	50	80	100
Ratio	i []	30	50	80	100
Repeatable peak torque	T_R [Nm]	9.0	18	23	28
Average torque	T_A [Nm]	6.8	6.9	11	11
Rated torque	T_N [Nm]	4.0	5.4	7.8	7.8
Momentary peak torque	T_M [Nm]	17	35	47	54
Maximum input speed (oil lubrication)	$n_{in(max)}$ [rpm]	14000			
Maximum input speed (grease lubrication)	$n_{in(max)}$ [rpm]	8500			
Average input speed (oil lubrication)	$n_{av(max)}$ [rpm]	6500/1100 ¹⁾			
Average input speed (grease lubrication)	$n_{av(max)}$ [rpm]	3500/1100 ¹⁾			
Moment of inertia HFUS-2UH	J_{in} [$\times 10^{-4}$ kgm ²]	0.091			
Moment of inertia HFUS-2SO	J_{in} [$\times 10^{-4}$ kgm ²]	0.033			
Moment of inertia HFUS-2SH	J_{in} [$\times 10^{-4}$ kgm ²]	0.091			
Weight HFUS-2UH	m [kg]	0.71			
Weight HFUS-2SO	m [kg]	0.41			
Weight HFUS-2SH	m [kg]	0.45			

¹⁾Valid for HFUS-2UH and HFUS-2SH when radial shaft seals are used on the hollow shaft.

Table 10.2

	Unit	HFUS-17				
		30	50	80	100	120
Ratio	i []	30	50	80	100	120
Repeatable peak torque	T_R [Nm]	16	34	43	54	54
Average torque	T_A [Nm]	12	26	27	39	39
Rated torque	T_N [Nm]	8.8	16	22	24	24
Momentary peak torque	T_M [Nm]	30	70	87	110	86
Maximum input speed (oil lubrication)	$n_{in(max)}$ [rpm]	10000				
Maximum input speed (grease lubrication)	$n_{in(max)}$ [rpm]	7300				
Average input speed (oil lubrication)	$n_{av(max)}$ [rpm]	6500/1100 ¹⁾				
Average input speed (grease lubrication)	$n_{av(max)}$ [rpm]	3500/1100 ¹⁾				
Moment of inertia HFUS-2UH	J_{in} [$\times 10^{-4}$ kgm ²]	0.193				
Moment of inertia HFUS-2SO	J_{in} [$\times 10^{-4}$ kgm ²]	0.079				
Moment of inertia HFUS-2SH	J_{in} [$\times 10^{-4}$ kgm ²]	0.193				
Weight HFUS-2UH	m [kg]	1.0				
Weight HFUS-2SO	m [kg]	0.57				
Weight HFUS-2SH	m [kg]	0.63				

¹⁾Valid for HFUS-2UH and HFUS-2SH when radial shaft seals are used on the hollow shaft.

3.3.2 Dimensions

Illustration 11.1 HFUS-14-2UH [mm]

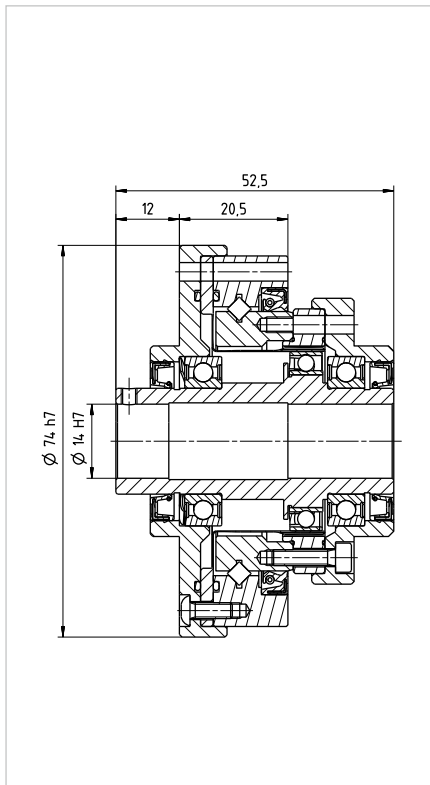

Illustration 11.2 HFUS-14-2SO [mm]

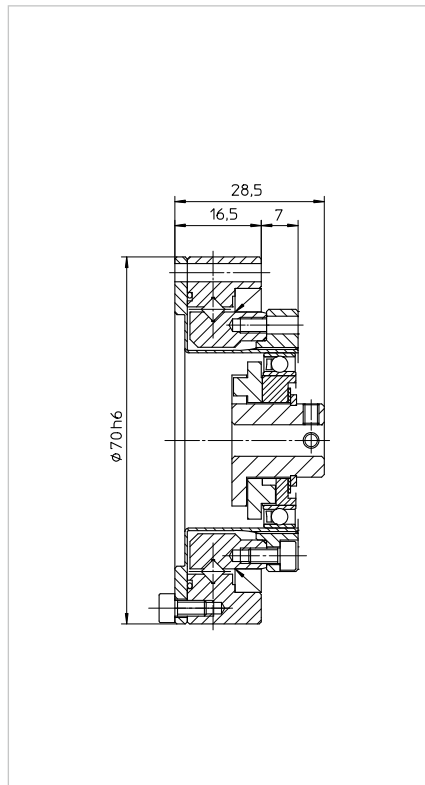

Illustration 11.3 HFUS-14-2SH [mm]

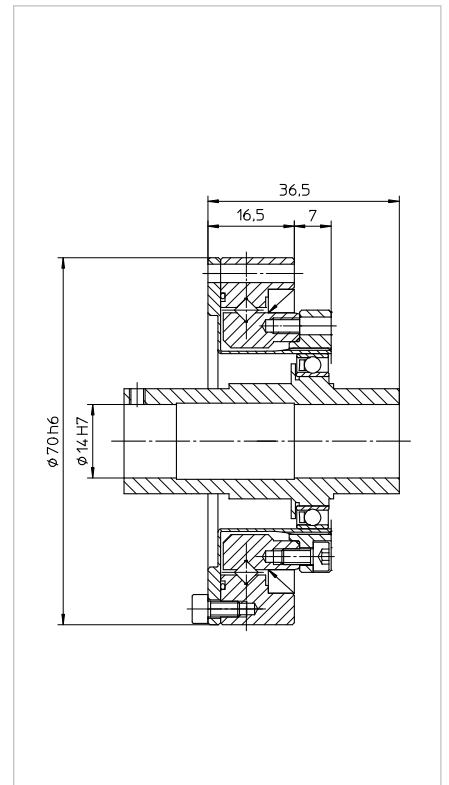

Illustration 11.4 HFUS-17-2UH [mm]

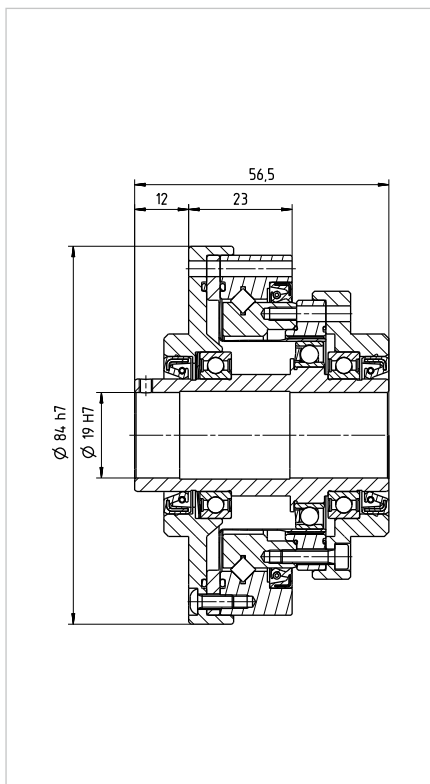

Illustration 11.5 HFUS-17-2SO [mm]

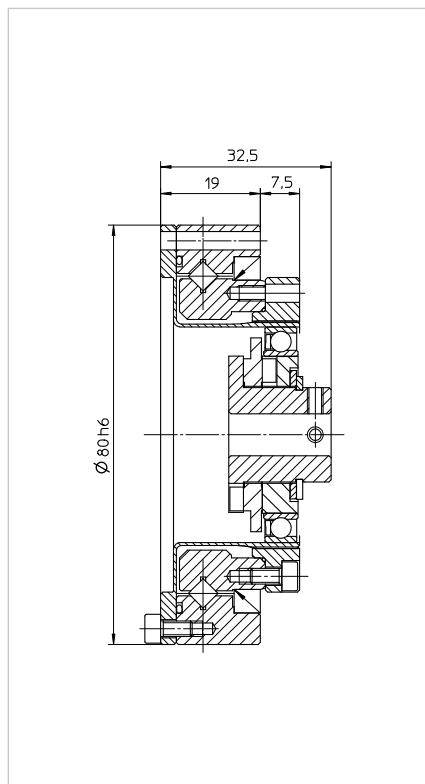

Illustration 11.6 HFUS-17-2SH [mm]

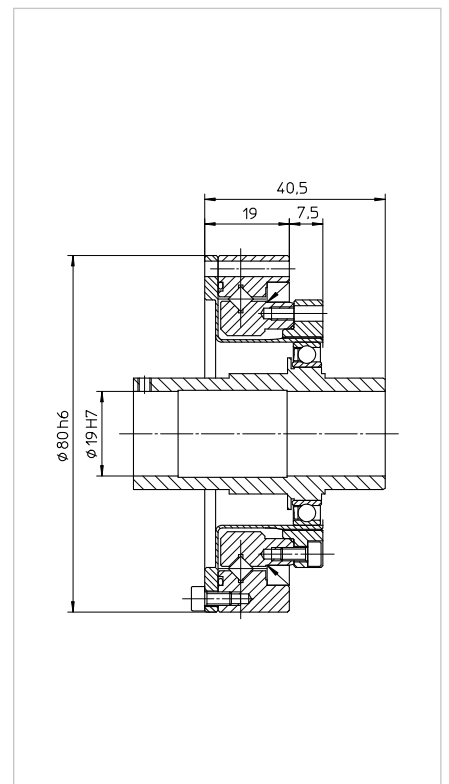

Table 12.1

	Unit	HFUS-20					
Ratio	i []	30	50	80	100	120	160
Repeatable peak torque	T_R [Nm]	27	56	74	82	87	92
Average torque	T_A [Nm]	20	34	47	49	49	49
Rated torque	T_N [Nm]	15	25	34	40	40	40
Momentary peak torque	T_M [Nm]	50	98	127	147	147	147
Maximum input speed (oil lubrication)	$n_{in(max)}$ [rpm]	10000					
Maximum input speed (grease lubrication)	$n_{in(max)}$ [rpm]	6500					
Average input speed (oil lubrication)	$n_{av(max)}$ [rpm]	6500/1100 ¹⁾					
Average input speed (grease lubrication)	$n_{av(max)}$ [rpm]	3500/1100 ¹⁾					
Moment of inertia HFUS-2UH	J_{in} [$\times 10^{-4}$ kgm ²]	0.404					
Moment of inertia HFUS-2SO	J_{in} [$\times 10^{-4}$ kgm ²]	0.193					
Moment of inertia HFUS-2SH	J_{in} [$\times 10^{-4}$ kgm ²]	0.404					
Weight HFUS-2UH	m [kg]	1.38					
Weight HFUS-2SO	m [kg]	0.81					
Weight HFUS-2SH	m [kg]	0.89					

¹⁾Valid for HFUS-2UH and HFUS-2SH when radial shaft seals are used on the hollow shaft.

Table 12.2

	Unit	HFUS-25					
Ratio	i []	30	50	80	100	120	160
Repeatable peak torque	T_R [Nm]	50	98	137	157	167	176
Average torque	T_A [Nm]	38	55	87	108	108	108
Rated torque	T_N [Nm]	27	39	63	67	67	67
Momentary peak torque	T_M [Nm]	95	186	255	284	304	314
Maximum input speed (oil lubrication)	$n_{in(max)}$ [rpm]	7500					
Maximum input speed (grease lubrication)	$n_{in(max)}$ [rpm]	5600					
Average input speed (oil lubrication)	$n_{av(max)}$ [rpm]	5600/1000 ¹⁾					
Average input speed (grease lubrication)	$n_{av(max)}$ [rpm]	3500/1000 ¹⁾					
Moment of inertia HFUS-2UH	J_{in} [$\times 10^{-4}$ kgm ²]	1.07					
Moment of inertia HFUS-2SO	J_{in} [$\times 10^{-4}$ kgm ²]	0.413					
Moment of inertia HFUS-2SH	J_{in} [$\times 10^{-4}$ kgm ²]	1.07					
Weight HFUS-2UH	m [kg]	2.1					
Weight HFUS-2SO	m [kg]	1.31					
Weight HFUS-2SH	m [kg]	1.44					

¹⁾Valid for HFUS-2UH and HFUS-2SH when radial shaft seals are used on the hollow shaft.

Illustration 13.1 HFUS-20-2UH [mm]

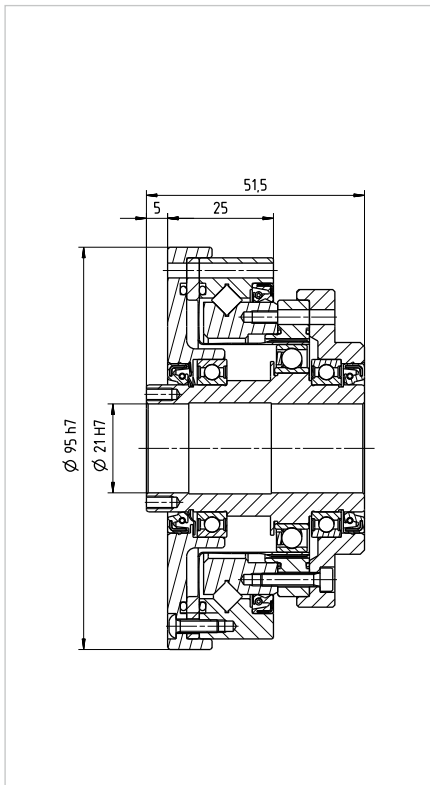

Illustration 13.2 HFUS-20-2SO [mm]

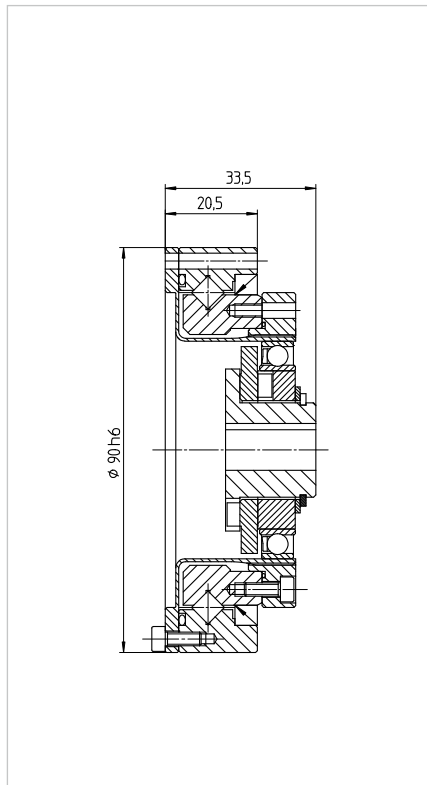

Illustration 13.3 HFUS-20-2SH [mm]

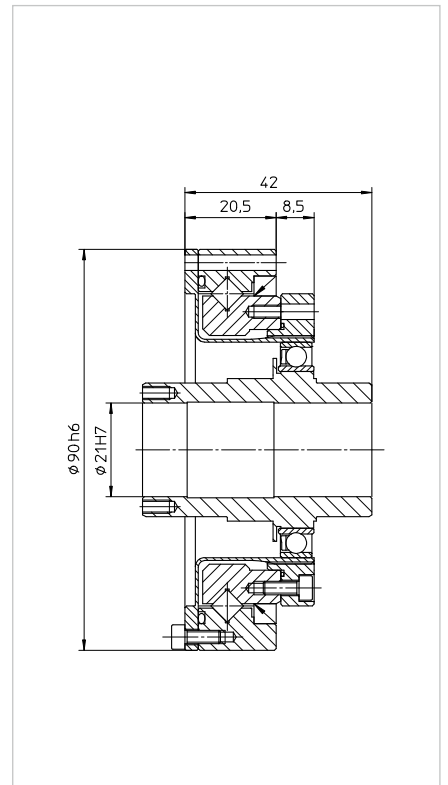

Illustration 13.4 HFUS-25-2UH [mm]

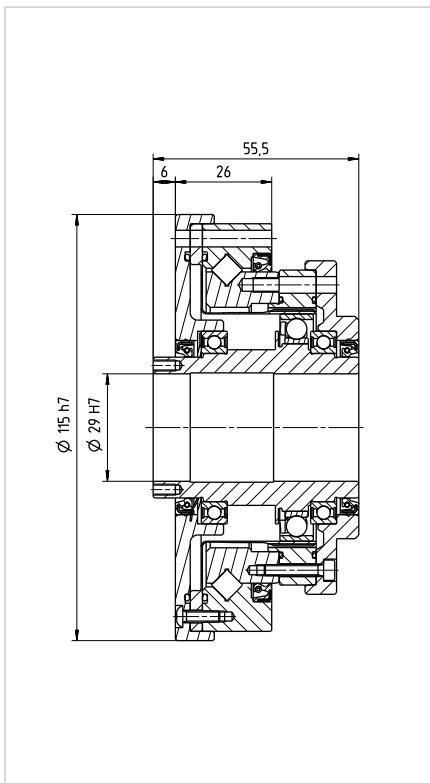

Illustration 13.5 HFUS-25-2SO [mm]

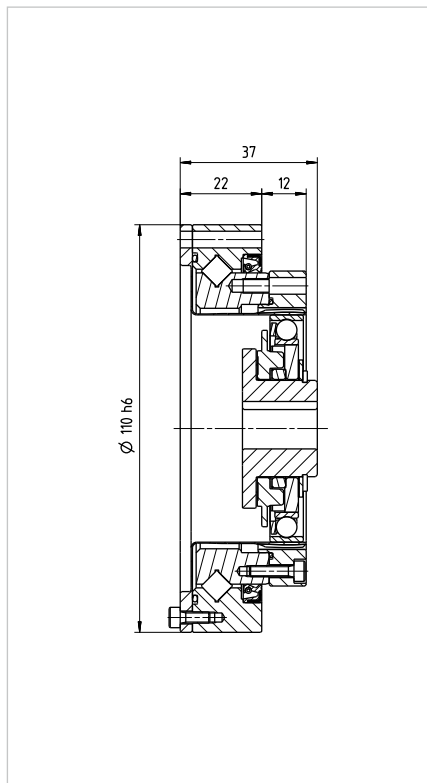

Illustration 13.6 HFUS-25-2SH [mm]

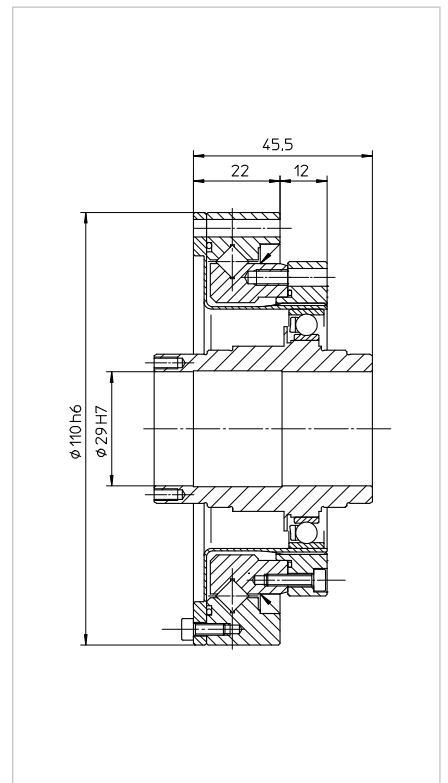

Table 14.1

	Unit	HFUS-32					
Ratio	i []	30	50	80	100	120	160
Repeatable peak torque	T_R [Nm]	100	216	304	333	353	372
Average torque	T_A [Nm]	75	108	167	216	216	216
Rated torque	T_N [Nm]	54	76	118	137	137	137
Momentary peak torque	T_M [Nm]	200	382	568	647	686	686
Maximum input speed (oil lubrication)	$n_{in(max)}$ [rpm]	7000					
Maximum input speed (grease lubrication)	$n_{in(max)}$ [rpm]	4800					
Average input speed (oil lubrication)	$n_{av(max)}$ [rpm]	4600/1000 ¹⁾					
Average input speed (grease lubrication)	$n_{av(max)}$ [rpm]	3500/1000 ¹⁾					
Moment of inertia HFUS-2UH	J_{in} [$\times 10^{-4}$ kgm ²]	2.85					
Moment of inertia HFUS-2SO	J_{in} [$\times 10^{-4}$ kgm ²]	1.69					
Moment of inertia HFUS-2SH	J_{in} [$\times 10^{-4}$ kgm ²]	2.85					
Weight HFUS-2UH	m [kg]	4.2					
Weight HFUS-2SO	m [kg]	2.9					
Weight HFUS-2SH	m [kg]	3.1					

¹⁾Valid for HFUS-2UH and HFUS-2SH when radial shaft seals are used on the hollow shaft.

Table 14.2

	Unit	HFUS-40				
Ratio	i []	50	80	100	120	160
Repeatable peak torque	T_R [Nm]	402	519	568	617	647
Average torque	T_A [Nm]	196	284	372	451	451
Rated torque	T_N [Nm]	137	206	265	294	294
Momentary peak torque	T_M [Nm]	686	980	1080	1180	1180
Maximum input speed (oil lubrication)	$n_{in(max)}$ [rpm]	5600				
Maximum input speed (grease lubrication)	$n_{in(max)}$ [rpm]	4000				
Average input speed (oil lubrication)	$n_{av(max)}$ [rpm]	3600/950 ¹⁾				
Average input speed (grease lubrication)	$n_{av(max)}$ [rpm]	3000/950 ¹⁾				
Moment of inertia HFUS-2UH	J_{in} [$\times 10^{-4}$ kgm ²]	9.28				
Moment of inertia HFUS-2SO	J_{in} [$\times 10^{-4}$ kgm ²]	4.50				
Moment of inertia HFUS-2SH	J_{in} [$\times 10^{-4}$ kgm ²]	9.28				
Weight HFUS-2UH	m [kg]	7.7				
Weight HFUS-2SO	m [kg]	5.1				
Weight HFUS-2SH	m [kg]	5.4				

¹⁾Valid for HFUS-2UH and HFUS-2SH when radial shaft seals are used on the hollow shaft.

Illustration 15.1 HFUS-32-2UH [mm]

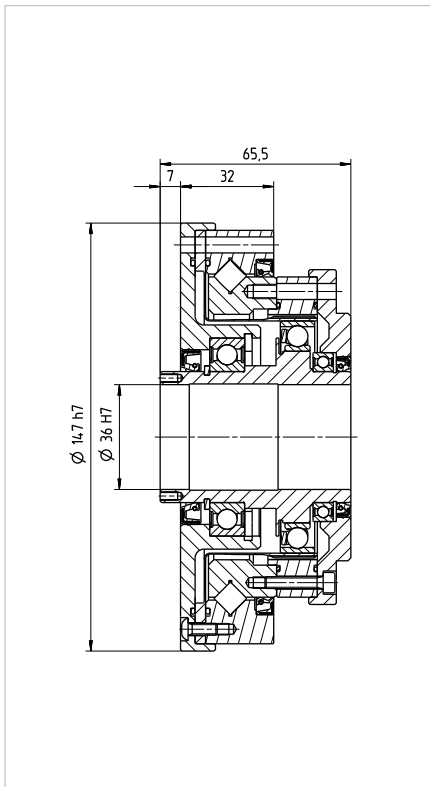

Illustration 15.2 HFUS-32-2SO [mm]

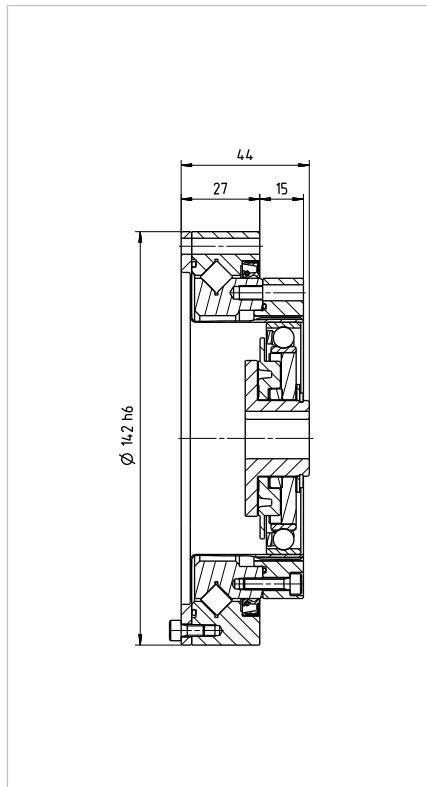

Illustration 15.3 HFUS-32-2SH [mm]

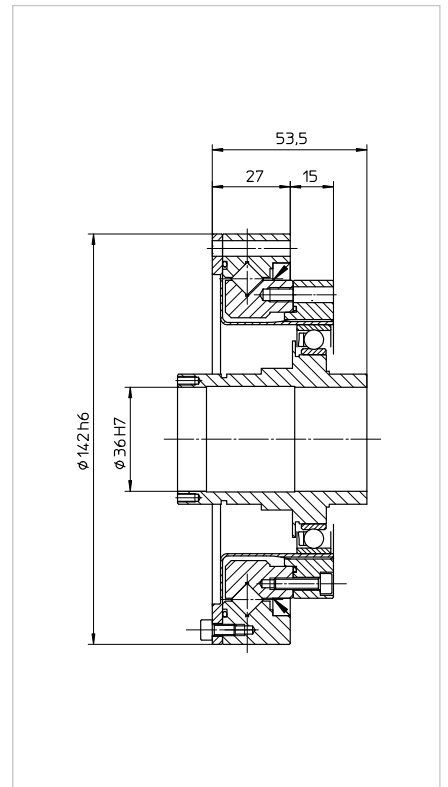

Illustration 15.4 HFUS-40-2UH [mm]

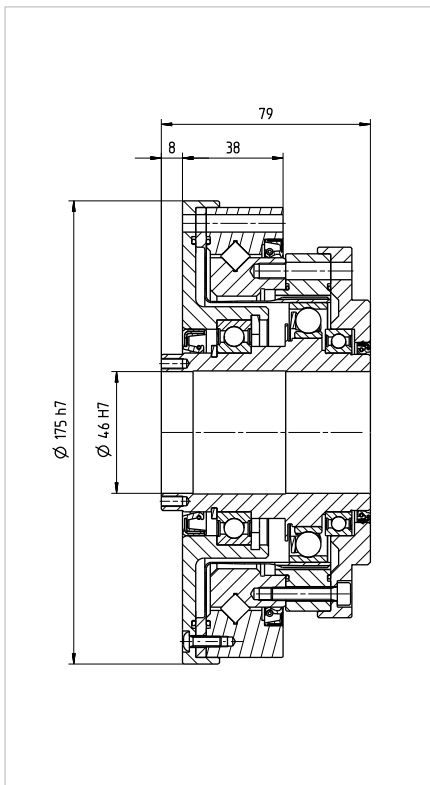

Illustration 15.5 HFUS-40-2SO [mm]

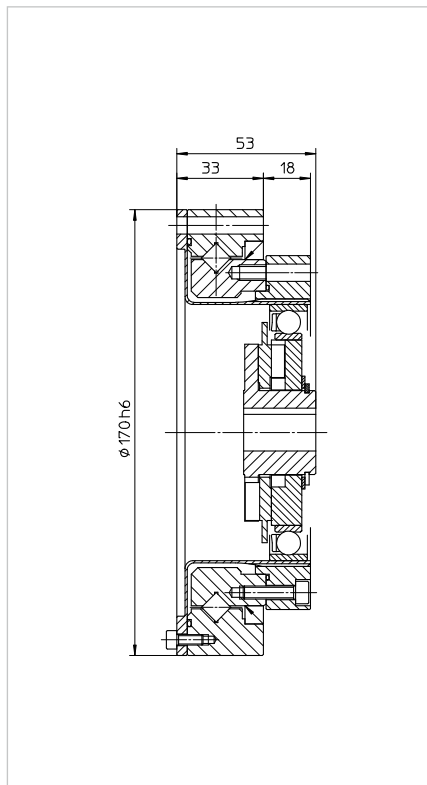

Illustration 15.6 HFUS-40-2SH [mm]

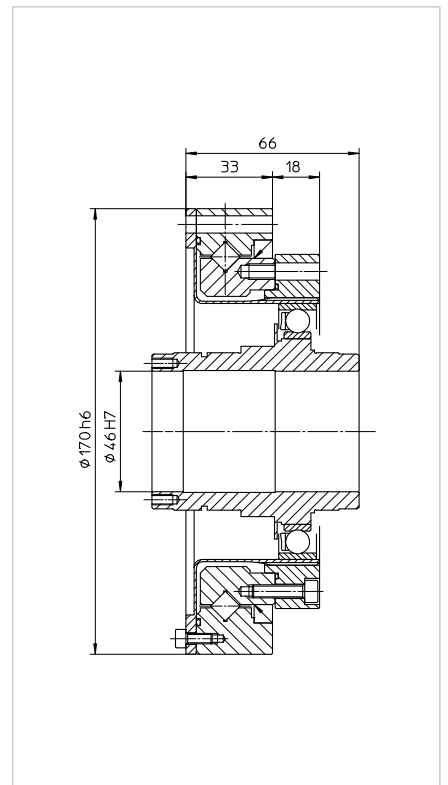

Table 16.1

	Unit	HFUS-45				
Ratio	i []	50	80	100	120	160
Repeatable peak torque	T_R [Nm]	500	706	755	823	882
Average torque	T_A [Nm]	265	390	500	620	630
Rated torque	T_N [Nm]	176	313	353	402	402
Momentary peak torque	T_M [Nm]	950	1270	1570	1760	1910
Maximum input speed (oil lubrication)	$n_{in(max)}$ [rpm]	5000				
Maximum input speed (grease lubrication)	$n_{in(max)}$ [rpm]	3800				
Average input speed (oil lubrication)	$n_{av(max)}$ [rpm]	3300/900 ¹⁾				
Average input speed (grease lubrication)	$n_{av(max)}$ [rpm]	3000/900 ¹⁾				
Moment of inertia HFUS-2UH	J_{in} [$\times 10^{-4}$ kgm ²]	13.8				
Moment of inertia HFUS-2SO	J_{in} [$\times 10^{-4}$ kgm ²]	8.68				
Moment of inertia HFUS-2SH	J_{in} [$\times 10^{-4}$ kgm ²]	13.8				
Weight HFUS-2UH	m [kg]	10				
Weight HFUS-2SO	m [kg]	6.5				
Weight HFUS-2SH	m [kg]	6.9				

¹⁾Valid for HFUS-2UH and HFUS-2SH when radial shaft seals are used on the hollow shaft.

Table 16.2

	Unit	HFUS-50				
Ratio	i []	50 ¹⁾	80	100	120	160
Repeatable peak torque	T_R [Nm]	715	941	980	1080	1180
Average torque	T_A [Nm]	350	519	666	813	843
Rated torque	T_N [Nm]	245	372	470	529	529
Momentary peak torque	T_M [Nm]	1430	1860	2060	2060	2450
Maximum input speed (oil lubrication)	$n_{in(max)}$ [rpm]	4500				
Maximum input speed (grease lubrication)	$n_{in(max)}$ [rpm]	3500				
Average input speed (oil lubrication)	$n_{av(max)}$ [rpm]	3000/850 ²⁾				
Average input speed (grease lubrication)	$n_{av(max)}$ [rpm]	2500/850 ²⁾				
Moment of inertia HFUS-2UH	J_{in} [$\times 10^{-4}$ kgm ²]	25.2				
Moment of inertia HFUS-2SO	J_{in} [$\times 10^{-4}$ kgm ²]	12.5				
Moment of inertia HFUS-2SH	J_{in} [$\times 10^{-4}$ kgm ²]	25.2				
Weight HFUS-2UH	m [kg]	14.5				
Weight HFUS-2SO	m [kg]	9.6				
Weight HFUS-2SH	m [kg]	10.2				

¹⁾ Only with oil lubrication. Grease lubrication can be used when the average torque T_{av} is not greater than half the nominal torque T_N .

²⁾ Valid for HFUS-2UH and HFUS-2SH when radial shaft seals are used on the hollow shaft.

Illustration 17.1 HFUS-45-2UH [mm]

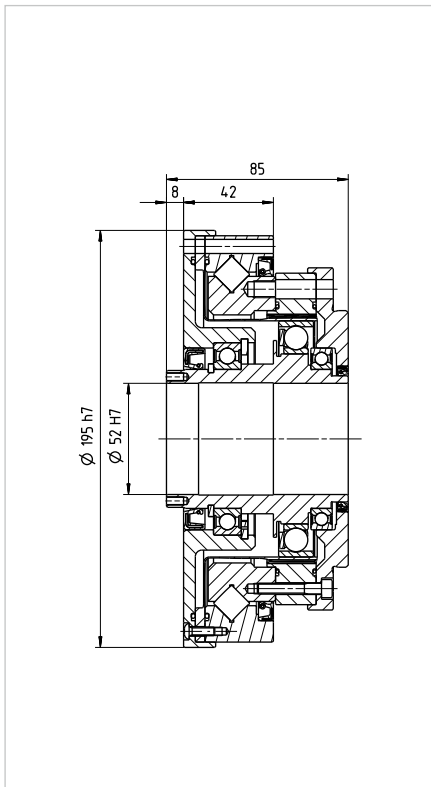

Illustration 17.2 HFUS-45-2SO [mm]

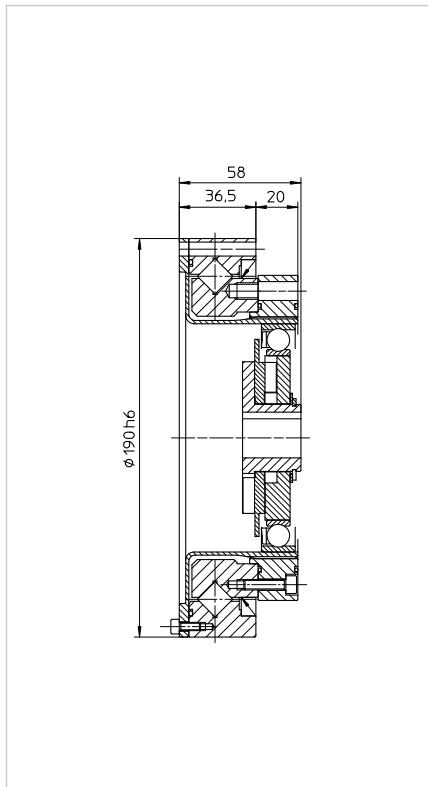

Illustration 17.3 HFUS-45-2SH [mm]

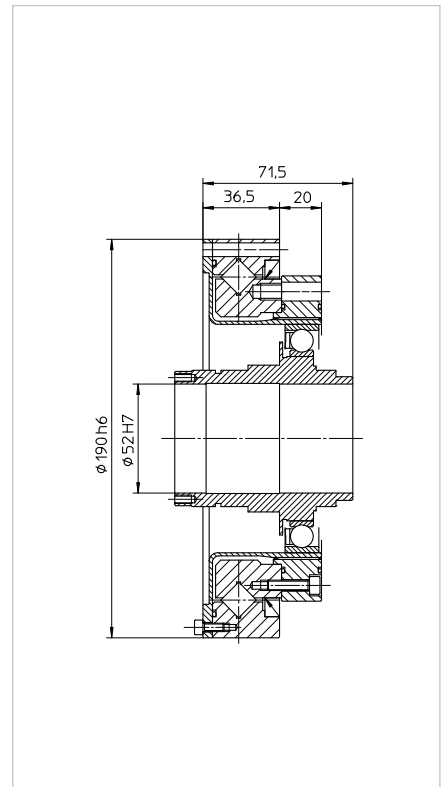

Illustration 17.4 HFUS-50-2UH [mm]

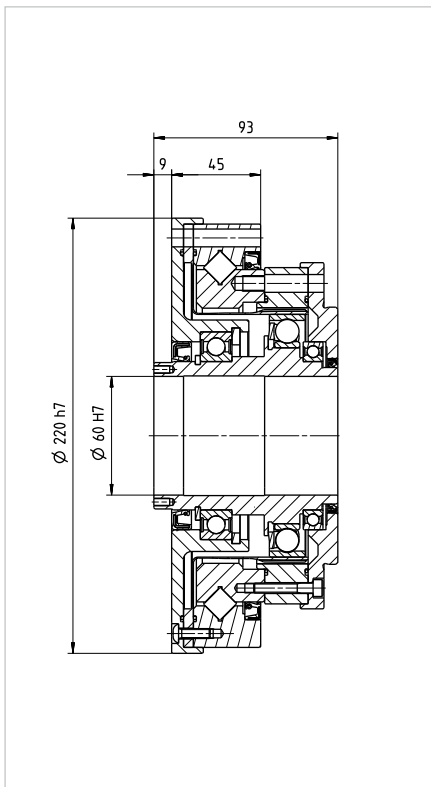

Illustration 17.5 HFUS-50-2SO [mm]

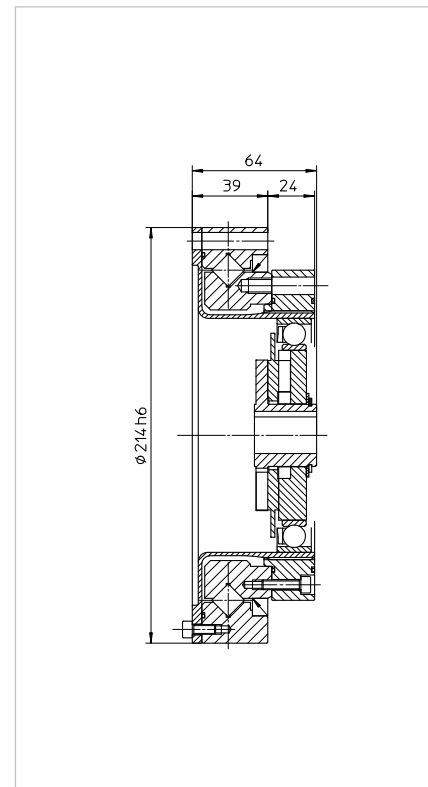

Illustration 17.6 HFUS-50-2SH [mm]

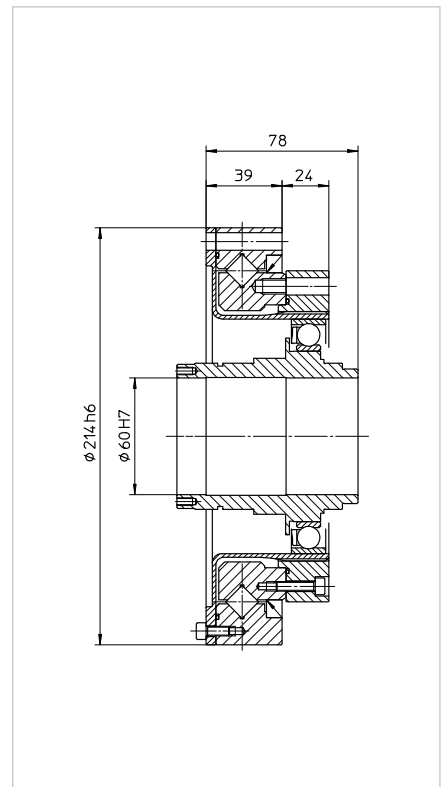

Table 18.1

	Unit	HFUS-58				
Ratio	i []	50 ¹⁾	80	100	120	160
Repeatable peak torque	T_R [Nm]	1020	1480	1590	1720	1840
Average torque	T_A [Nm]	520	770	1060	1190	1210
Rated torque	T_N [Nm]	353	549	696	745	745
Momentary peak torque	T_M [Nm]	1960	2450	3180	3330	3430
Maximum input speed (oil lubrication)	$n_{in(max)}$ [rpm]	4000				
Maximum input speed (grease lubrication)	$n_{in(max)}$ [rpm]	3000				
Average input speed (oil lubrication)	$n_{av(max)}$ [rpm]	2700/800 ²⁾				
Average input speed (grease lubrication)	$n_{av(max)}$ [rpm]	2200/800 ²⁾				
Moment of inertia HFUS-2UH	J_{in} [$\times 10^{-4}$ kgm ²]	49.5				
Moment of inertia HFUS-2SO	J_{in} [$\times 10^{-4}$ kgm ²]	27.3				
Moment of inertia HFUS-2SH	J_{in} [$\times 10^{-4}$ kgm ²]	49.5				
Weight HFUS-2UH	m [kg]	20				
Weight HFUS-2SO	m [kg]	13.5				
Weight HFUS-2SH	m [kg]	14.1				

¹⁾ Only with oil lubrication. Grease lubrication can be used when the average torque T_{av} is not greater than half the nominal torque T_N .

²⁾ Valid for HFUS-2UH and HFUS-2SH when radial shaft seals are used on the hollow shaft.

Illustration 19.1 HFUS-58-2UH [mm]

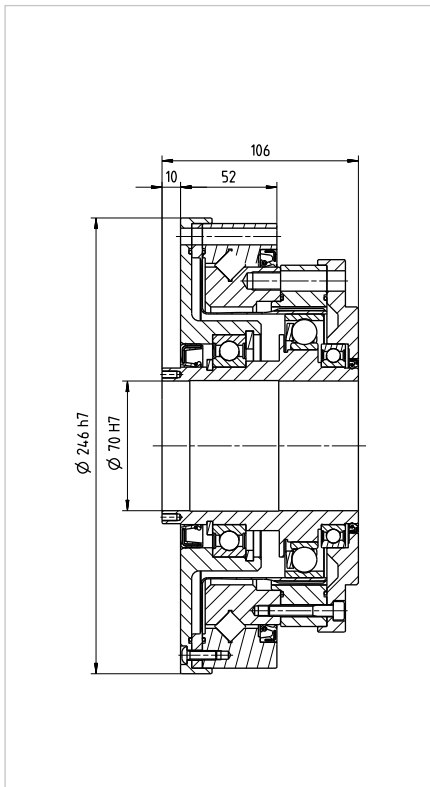

Illustration 19.2 HFUS-58-2SO [mm]

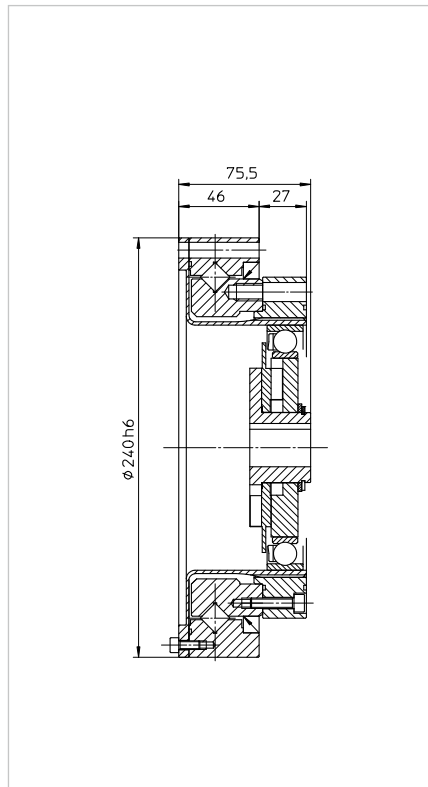
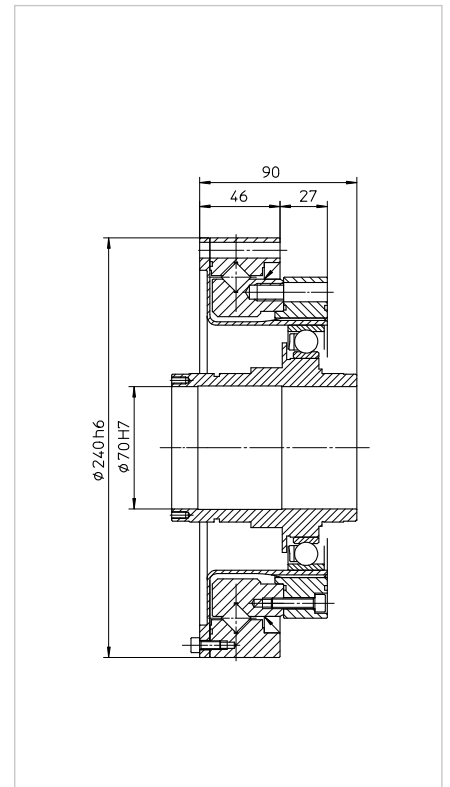

Illustration 19.3 HFUS-58-2SH [mm]



3.3.3 Minimum Housing Dimensions HFUS-250 and HFUS-25H

Table 20.1

[mm]

Size	14	17	20	25	32	40	45	50	58
ØW	31	38	45	56	73	90	101	113	131
X	1.0	1.0	1.5	1.5	1.5	2.0	2.3	2.5	2.5
Y	1.7	2.1	2.0	2.0	2.0	2.0	2.3	2.5	2.9
ØZ	38	45	45	66	86	106	119	133	154

Illustration 20.2

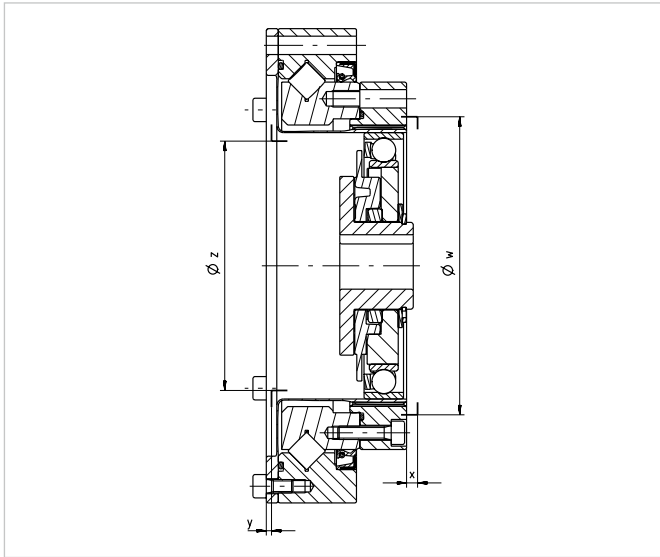

3.3.4 Accuracy

Table 20.3

[arcmin]

Size	14		17		≥ 20	
Ratio	30	≥ 50	30	≥ 50	30	≥ 50
Transmission accuracy ¹⁾	<2	<1.5	<1.5	<1.5	<1.5	<1
Hysteresis loss	<3	<1	<3	<1	<3	<1
Lost Motion	< 1					
Repeatability	< ± 0.1					

¹⁾ Higher accuracy on request

3.3.5 Torsional Stiffness

Table 20.4

Size	14	17	20	25	32	40	45	50	58
T ₁ [Nm]	2	3.9	7	14	29	54	76	108	168
T ₂ [Nm]	6.9	12	25	48	108	196	275	382	598
i = 30	K ₃ [x10 ³ Nm/rad]	3.4	6.7	11	21	49	-	-	-
	K ₂ [x10 ³ Nm/rad]	2.4	4.4	7.1	13	30	-	-	-
	K ₁ [x10 ³ Nm/rad]	1.9	3.4	5.7	10	24	-	-	-
i = 50	K ₃ [x10 ³ Nm/rad]	5.7	13	23	44	98	180	260	340
	K ₂ [x10 ³ Nm/rad]	4.7	11	18	34	78	140	200	280
	K ₁ [x10 ³ Nm/rad]	3.4	8.1	13	25	54	100	150	200
i > 50	K ₃ [x10 ³ Nm/rad]	7.1	16	29	57	12	230	330	440
	K ₂ [x10 ³ Nm/rad]	6.1	14	25	50	11	200	290	400
	K ₁ [x10 ³ Nm/rad]	4.7	10	16	31	67	130	180	250

3.3.6 Bearings

Output Bearing

HFUS units incorporate a high stiffness cross roller bearing to support output loads. This specially developed bearing can withstand high axial and radial forces as well as high tilting moments. The reduction gear is thus protected from external loads, so guaranteeing a long life and constant performance. The integration of an output bearing also serves to reduce subsequent design and production cost, by removing the need for additional output bearings in many applications. However, in some applications the machine element to be driven requires additional bearing support. In this case, please take care to avoid overdetermination of the bearing arrangement. The cross roller bearing of the unit should be used as the fixed bearing, whilst the additional support bearing should be floating, if possible. Table 21.1 lists ratings and important dimensions for the output bearings.

Table 21.1

Size		14	17	20	25	32	40	45	50	58
Bearing type ¹⁾		C	C	C	C	C	C	C	C	C
Pitch circle \varnothing	d_p [m]	0.050	0.060	0.070	0.085	0.111	0.133	0.154	0.170	0.195
Abstand ²⁾	R [m]	0.022	0.024	0.026	0.030	0.036	0.044	0.048	0.053	0.062
Dynamic load rating	C [N]	5800	10400	14600	21800	38200	43300	77600	81600	87400
Static load rating	C_0 [N]	8600	16300	22000	35800	65400	81600	135000	149000	171000
Permissible dynamic tilting moment ³⁾	M [Nm]	74	124	187	258	580	849	1127	1487	2180
Permissible static tilting moment ⁴⁾	M_0 [Nm]	144	328	515	1070	2425	3623	6949	8505	11159
Tilting moment stiffness ⁵⁾	K_B [Nm/arcmin]	25	45	74	114	290	522	749	1020	1550
Permissible axial load ⁵⁾	F_a [N]	3044	5468	7687	11504	20119	22750	40858	42973	46017
Permissible radial load ⁵⁾	F_r [N]	2039	3664	5150	7708	13480	15243	27375	28792	30831

Normally, the gear life is determined by the life of the Wave Generator bearing. Depending on the specific load conditions the output bearing can also be determinant for the gear life.

¹⁾ These values are valid for moving gears. They are not based on the equation for lifetime calculation of the output bearing but on the maximum allowable deflection of the Harmonic Drive® component set. The values indicated in the table must not be exceeded even if the lifetime equation of the bearing permits higher values.

²⁾ These values are valid for gears at a standstill and for a static load safetyfactor $f_s = 1.5$. For other values of f_s , please refer to section 4.7 Life for continuous operation.

³⁾ These data are valid for: $f_W = 1,3$; $n = 15$ rpm and $L_{10} = 15000$ h.

⁴⁾ Depending on the bearing manufacturer the pitch circle diameter may differ slightly from the data given in the catalogue.

⁵⁾ Average value

¹⁰²³⁾ These data are only valid if the following conditions are fulfilled: For: M, M_0 : $F_a = 0$, $F_r = 0$ | F_a : $M = 0$; $F_r = 0$ | F_r : $M = 0$, $F_a = 0$

Output Bearing and Housing Tolerances

In the case of the SHG-2UH Unit the load is connected to the output bearing by means of a flange. Depending on the manner of fastening, either the flange which is connected to the outer ring, or the flange which is connected to the internal ring of the output bearing, can be used as output element (see illustration 22.1 and illustration 22.2). The tolerance values indicated in table 22.3 are the sum of bearing and flange tolerances.

Illustration 22.1

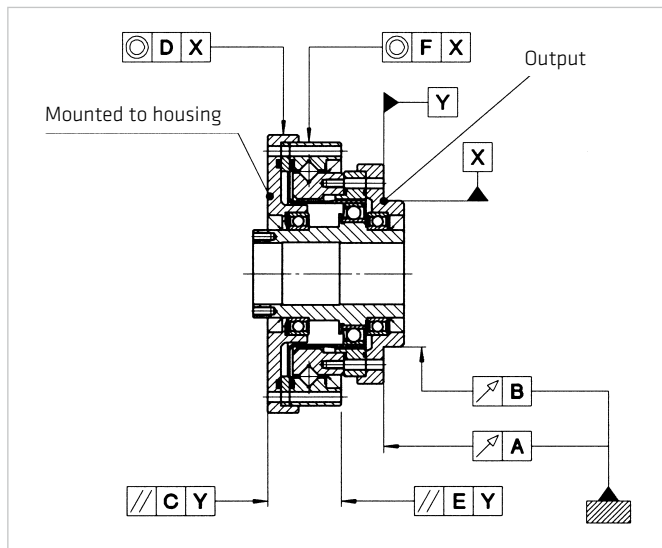

Illustration 22.2

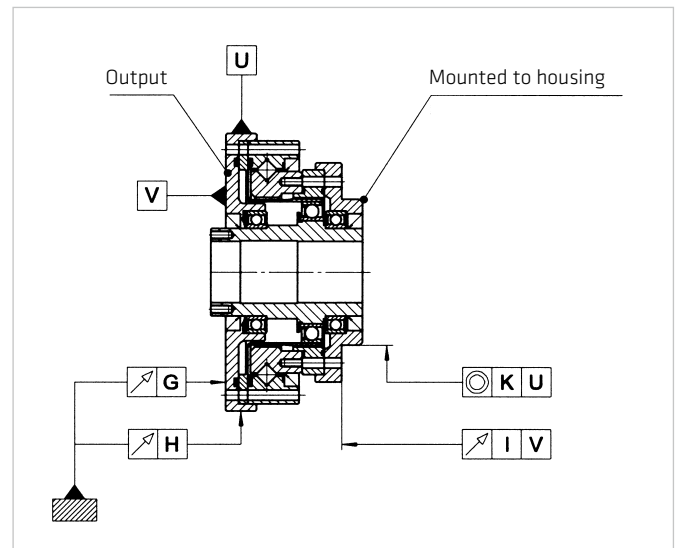

Table 22.3

[mm]

Size	14	17	20	25	32	40	45	50	58
A	0.033	0.038	0.040	0.046	0.054	0.057	0.057	0.063	0.063
B	0.035	0.035	0.039	0.041	0.047	0.050	0.053	0.060	0.063
C	0.064	0.071	0.079	0.085	0.104	0.111	0.118	0.121	0.121
D	0.053	0.053	0.059	0.061	0.072	0.075	0.078	0.085	0.088
E	0.040	0.045	0.051	0.057	0.065	0.071	0.072	0.076	0.076
F	0.038	0.038	0.047	0.049	0.054	0.060	0.065	0.067	0.070
G	0.037	0.039	0.046	0.047	0.059	0.063	0.070	0.070	0.070
H	0.031	0.031	0.038	0.038	0.045	0.048	0.050	0.050	0.050
I	0.064	0.071	0.079	0.085	0.104	0.111	0.118	0.121	0.121
K	0.053	0.053	0.059	0.061	0.072	0.075	0.078	0.085	0.088

Input Bearing HFUS-2UH

The hollow shaft incorporated in the HFUS-2UH unit is supported by two single row deep groove ball bearings. Illustration 23.2 shows the points of application of force of the maximum permissible radial and axial loads as indicated in illustrations 24.1 and 24.2.

Example: If the hollow shaft of a HFUS-40-2UH unit is subjected to an axial load of 500 N, then the maximum permissible radial force will be 570 N, see illustration 24.1 and 24.2.

The maximum values shown are valid for an average input speed of 2000 rpm and a mean bearing life of $L_{50} = 35000$ h. For HFUS-2UH units of size 14 up to 25 the bearing A is pretensioned in axial direction by means of roller bearing compensation washers. If the hollow shaft is subjected to an axial force acting in the negative direction ($-F_a$, see illustration 24.2) it can be shifted for the value „s” given in table 23.1. For the size 32 up to 58 the bearing A is designed as a fixed bearing.

Table 23.1

Size		14	17	20	25	32	40	45	50	58
Bearing A	C [N]	4000	4300	4500	4900	14100	19400	17400	24400	32000
	C_0 [N]	2470	2950	3450	4350	10900	16300	16100	22600	29600
Bearing B	C [N]	4000	4300	4500	4900	5350	11500	11900	12500	18700
	C_0 [N]	2470	2950	3450	4350	5250	10900	12100	13900	20000
Offset	a [mm]	27	29	27	29.5	33	39.5	44	49	56.2
Offset	b [mm]	16.5	17.5	15.5	16.5	23.0	27.5	28.5	31.5	36.5
Max. permissible radial load	F [N]	263	284	303	275	813	1210	1000	1550	2060
Max. axial movement of hollow shaft at axial force = $-F_a$	s [mm]	1.8	2.8	2.4	3.2	-	-	-	-	-

Illustration 23.2

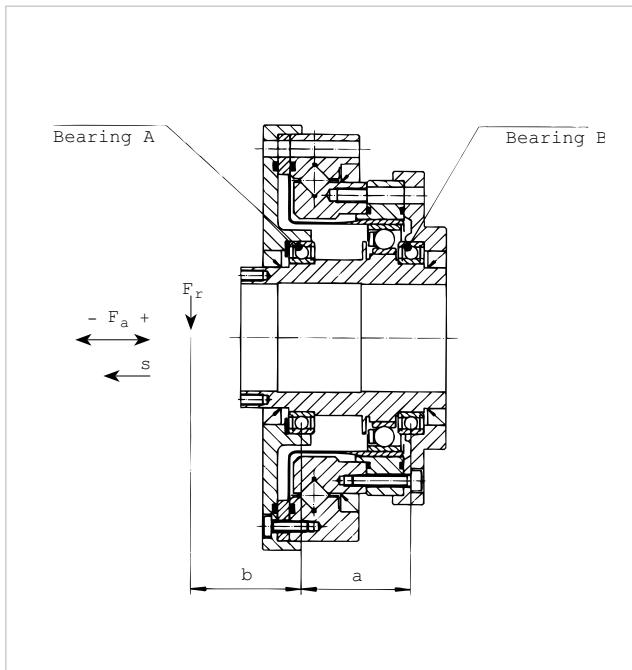

Illustration 24.1

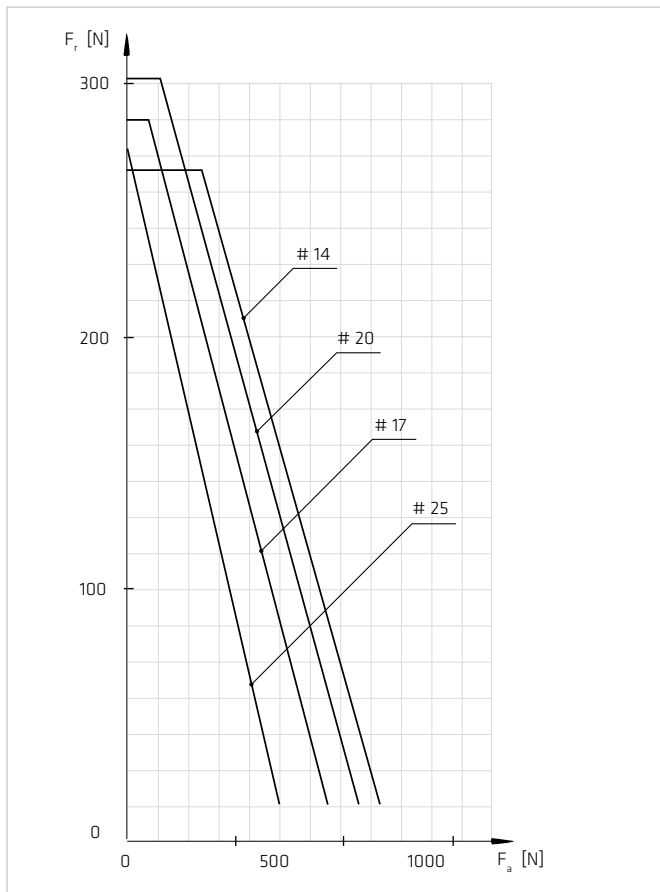
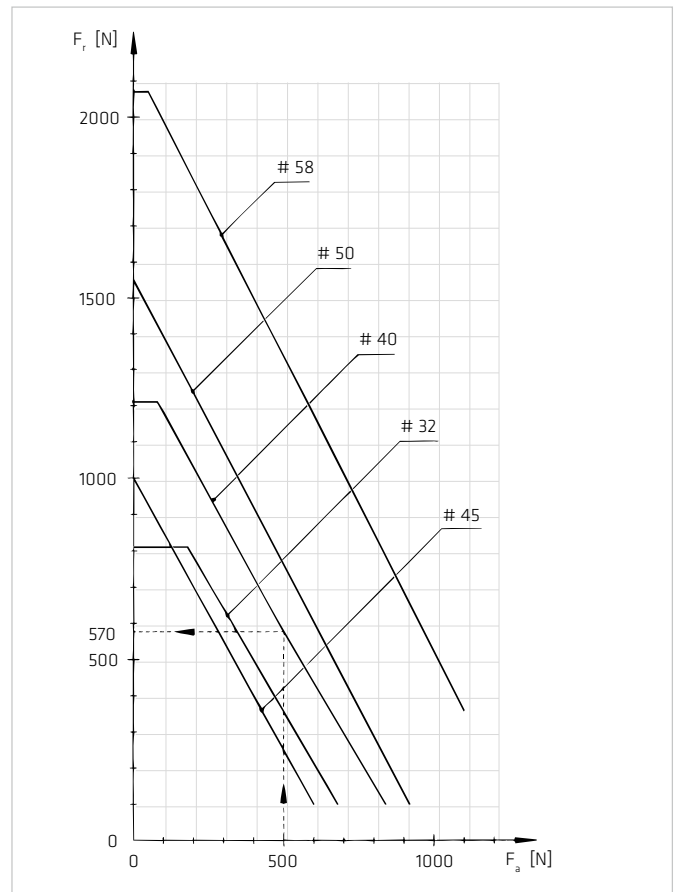

Illustration 24.2



3.3.7. Housing Materials and Surfaces

Materials:

Housing: cast iron and bearing steel.

Adapter flange, if supplied by Harmonic Drive AG: high tensile aluminium or steel.

Surfaces:

Screws: black phosphatized.

Housing: Bright.

Output bearing: Bright bearing steel.

4. Actuator Selection

A variety of different driving arrangements are possible with Harmonic Drive® gears.

Equation 25.1

Ratio $i =$	$\frac{\text{Input speed}}{\text{Output speed}}$
-------------	--

Overview Harmonic Drive® Products

The three main components of the Harmonic Drive® units, Circular Spline (CS), Flexspline (FS) and Wave Generator (WG) can be seen in the illustration 25.2.

Illustration 25.2

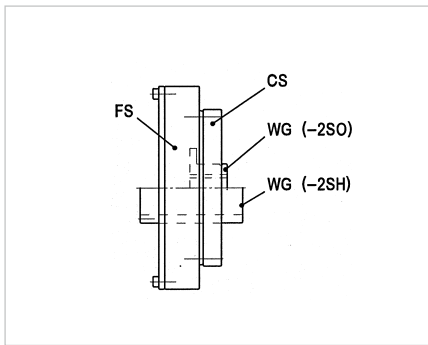

The values for ratios of Harmonic Drive® gears refer to the standard input and output arrangement (example 1 in the table below). Other arrangements are possible, and also shown in the table.

Ratio

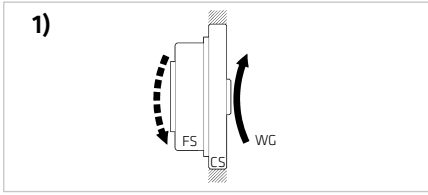

Reduction gearing

CS Fixed
WG Input
FS Output

Equation 26.1

$$\text{Ratio} = - \frac{i}{1}$$

Input and output rotate in opposite directions.

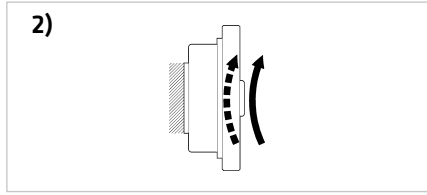

Reduction gearing

FS Fixed
WG Input
CS Output

Equation 26.2

$$\text{Ratio} = \frac{i+1}{1}$$

Input and output rotate in same direction.

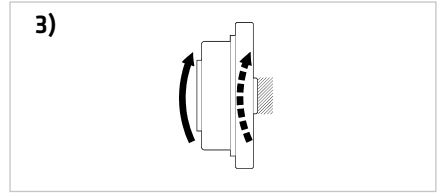

Reduction gearing

WG Fixed
FS Input
CS Output

Equation 26.3

$$\text{Ratio} = \frac{i+1}{1}$$

Input and output rotate in same direction.

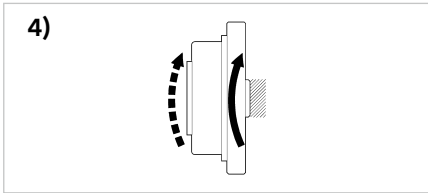

Speed increaser gearing

WG Fixed
CS Input
FS Output

Equation 26.4

$$\text{Ratio} = \frac{i}{i+1}$$

Input and output rotate in same direction.

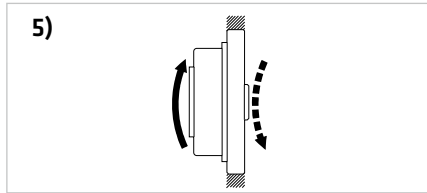

Speed increaser gearing

CS Fixed
FS Input
WG Output

Equation 26.5

$$\text{Ratio} = - \frac{1}{i}$$

Input and output rotate in opposite directions.

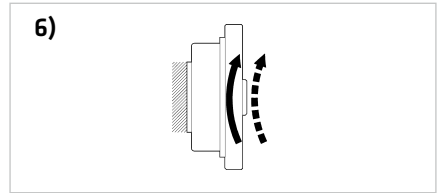

Speed increaser gearing

FS Fixed
CS Input
WG Output

Equation 26.6

$$\text{Ratio} = \frac{1}{i+1}$$

Input and output rotate in same direction.

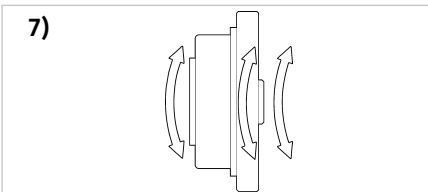

Differential gear

WG Control input
CS Main drive input
FS Main drive output

Numerous differential functions can be obtained by combinations of the speed and rotational direction of the three basic elements. Please refer to our brochure "Differential Applications" available to download from our website.

4.1 Selecting Harmonic Drive® Gears

When choosing a gear, both torque as well as stiffness requirements should be taken into account. In robot applications, for example, the necessary torque is the more crucial factor for the gear size, while the torsional stiffness is often decisive in machine tool applications. We therefore recommend that you always take both criteria into account according to the following procedures.

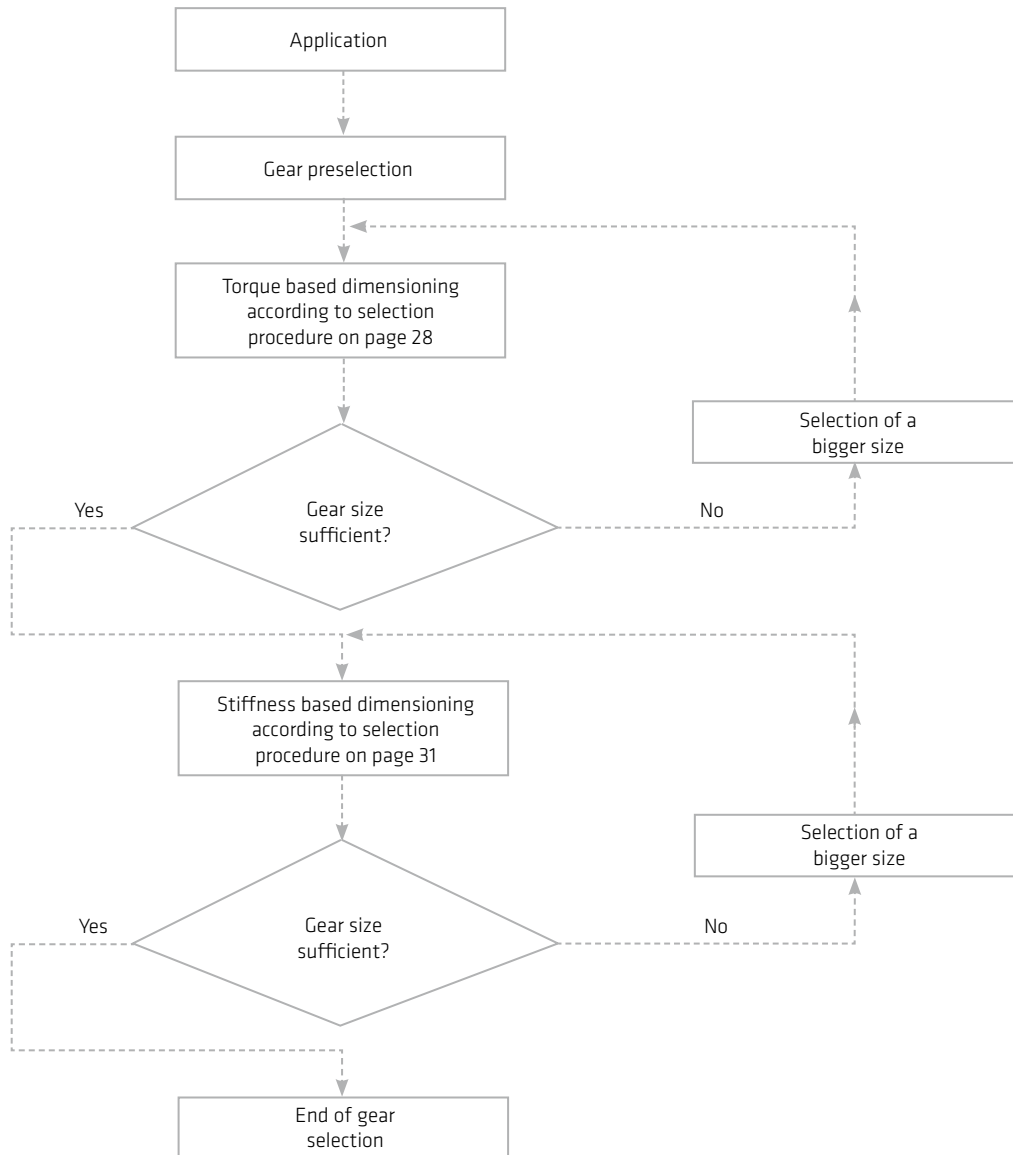

4.1.1 Torque Based Dimensioning

Output Data

Torques	$T_1...T_n$	[Nm]
during the load phases	$t_1...t_n$	[s]
during the pause time	t_p	[s]
and output speeds	$n_1...n_n$	[rpm]
Emergency stop/momentary peak torque	T_k	[Nm]
at output speed	n_k	[rpm]
and duration	t_k	[s]

Illustration 28.1

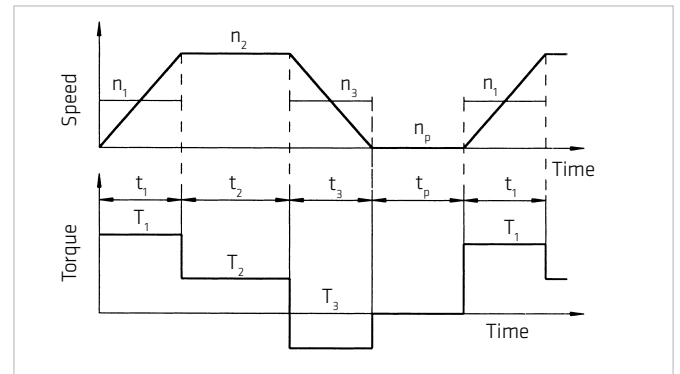

Equation 28.2

Load limit 1,
Calculation of the average output torque T_{av}

$$T_{av} = \sqrt[3]{\frac{|n_1 \cdot T_1^3| \cdot t_1 + |n_2 \cdot T_2^3| \cdot t_2 + \dots + |n_n \cdot T_n^3| \cdot t_n}{|n_1| \cdot t_1 + |n_2| \cdot t_2 + \dots + |n_n| \cdot t_n}}$$

Equation 28.3



Equation 28.4

Calculation of the average output speed

$$n_{out\ av} = \frac{|n_1| \cdot t_1 + |n_2| \cdot t_2 + \dots + |n_n| \cdot t_n}{t_1 + t_2 + \dots + t_n + t_p}$$

Equation 28.5

Average input speed

$$n_{in\ av} = i \cdot n_{out\ av}$$

Equation 28.6

Permissible maximum input speed

$$n_{in\ max} = n_{out\ max} \cdot i \leq \text{Maximum input speed (see rating table)}$$

Equation 28.7

Permissible average input speed

$$n_{in\ av} \leq \text{Limit for average input speed (s. rating table)}$$

Equation 28.8

Load limit 2, T_R

$$T_{max} \leq T_R$$

Equation 28.9

Load limit 3, T_M

$$T_k \leq T_M$$

Equation 28.10

Allowable number of momentary peak torques

$$N_{k\ max} = \frac{10^4}{2 \cdot \frac{n_k}{60} \cdot t_k} < 10^4$$

Equation 28.11

Operating life

$$L_{50} = L_n \cdot \frac{\text{Rated input speed}}{n_{in\ av}} \cdot \left(\frac{\text{Rated torque } T_N}{T_{av}} \right)^3$$

Values for L_n see table 30.1

Output Data

$T_1 = 400 \text{ Nm}$	$t_1 = 0.3 \text{ s}$	$n_1 = 7 \text{ rpm}$
$T_2 = 320 \text{ Nm}$	$t_2 = 3.0 \text{ s}$	$n_2 = 14 \text{ rpm}$
$T_3 = 200 \text{ Nm}$	$t_3 = 0.4 \text{ s}$	$n_3 = 7 \text{ rpm}$
$T_k = 500 \text{ Nm}$	$t_k = 0.15 \text{ s}$	$n_k = 14 \text{ rpm}$
	$t_p = 0.2 \text{ s}$	$n_p = 0 \text{ rpm}$
Ratio $i = 120$		
Life $L_{50} = 30000 \text{ h}$ (required)		

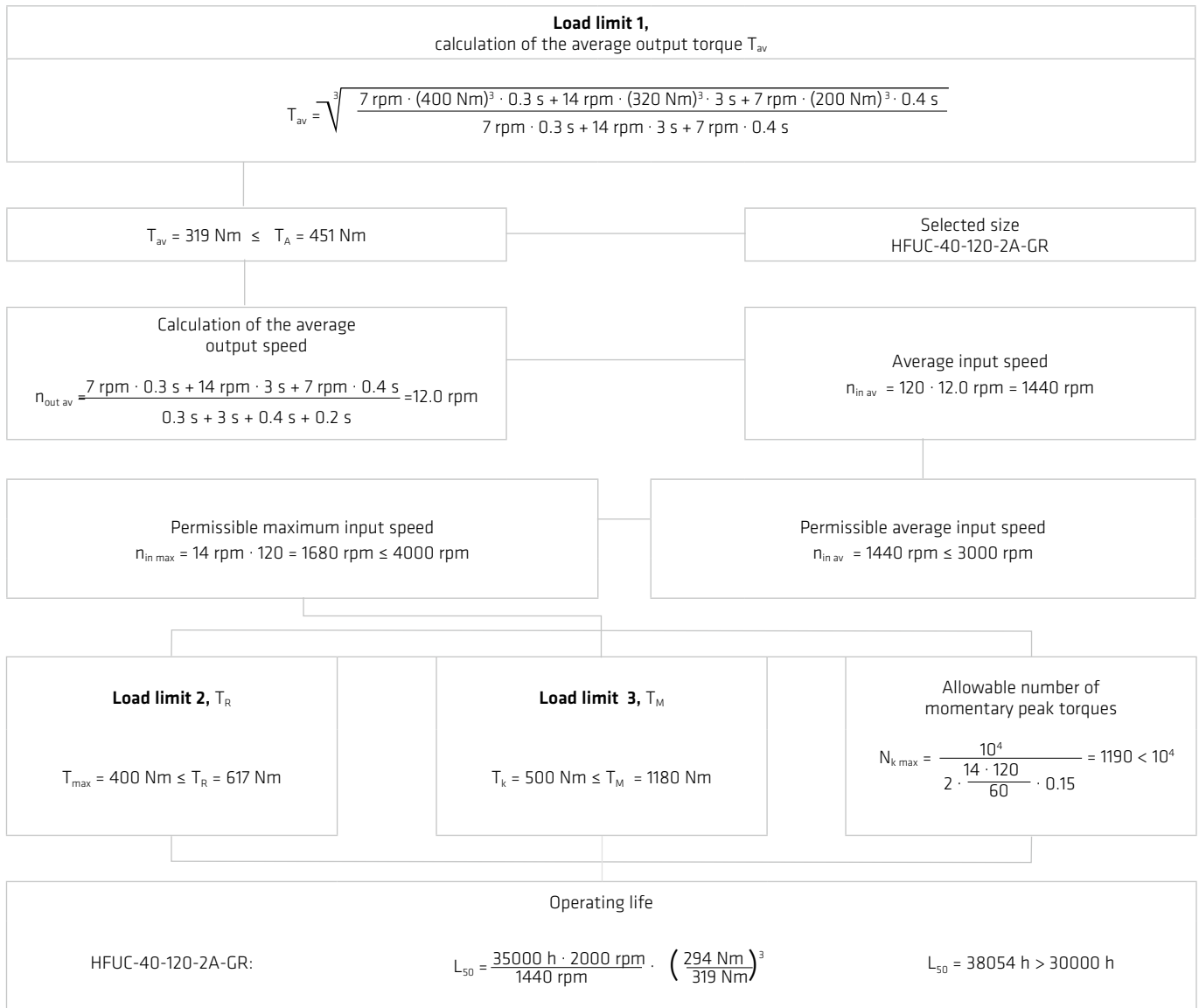

4.1.2 Life of the Wave Generator Bearing

Given that the Harmonic Drive® Gear is rated to provide infinite fatigue life for the Flexspline, the life expectancy is based on the average life of the Wave Generator bearing. The rated torque at the rated speed given in the rating table is based on the mean L_{50} bearing life.

The life expectancy of a component set or an unit operating at an input speed n (rpm) and output torque T (Nm) may be estimated from equation 30.2.

Table 30.1

[h]

Harmonic Drive® series	L_n
CobaltLine, CSG, SHG	50000
HFUC, HFUS, CSD, CPU, CSF, SHD	35000
PMG gearbox	15000

Equation 30.2

$$L_{50} = L_n \frac{n_N}{n_{in\ av}} \left(\frac{T_N}{T_{av}} \right)^3$$

Equation 30.3

$$L_{10} \approx \frac{1}{5} \cdot L_{50}$$

n_N = Rated input speed [rpm]

$n_{in\ av}$ = Average input speed [rpm] (equation 28.5)

T_N = Rated output torque at rated speed [Nm]

T_{av} = Average output torque [Nm] (equation 28.2)

L_n = See table 30.1

4.1.3 Stiffness Based Dimensioning

In addition to the “Torque Based Dimensioning” stated on page 28, we recommend that you carry out a selection based on stiffness. For this, the values provided in table 31.1 for the individual resonance frequencies recommended for each application should be taken into account.

Table 31.1

[Hz]

Application	f_n
Slowly rotating turntables, base axes of slow moving welding robots (not laser welding), slowly rotating welding and swinging tables, gantry robot axes	≥ 4
Base axes of revolute robots, hand axes of revolute robots with low requirements regarding dynamic performance, tool revolvers, tool magazines, swivelling and positioning axes in medical and measuring devices	≥ 8
Standard applications in general mechanical engineering, tilting axes, palette changers, highly dynamic tool changers, revolvers and magazines, hand axes of robots, scara robots, gantry robots, polishing robots, dynamic welding manipulators, base axes of welding robots (laser welding), swivelling and positioning axes of medical equipment	≥ 15
B/C axes in 5 axis grinding machines, hand axes of welding robots (laser welding), milling heads for plastics machining	≥ 20
C axes in turning machines, milling heads for light metal machining, milling heads for woodworking (chipboards etc.)	≥ 25
Milling heads for woodworking (hardwood etc.)	≥ 30
C axes in turning machines*	≥ 35
Milling heads for metal machining*, B axes in turning milling centers for metal machining	≥ 40
Milling heads for metal machining*, B axes in turning milling centers for metal machining with high requirements regarding surface quality*	≥ 50
Milling heads for metal machining with very high requirements regarding surface quality*	≥ 60

* Depending on the application, a secondary gear stage may be useful. Please contact Harmonic Drive AG for more information..

Selection Example: Stiffness Based Dimensioning

Resonance Frequency (Gear Output)

The formula

Equation 32.1

$$f_n = \frac{1}{2\pi} \sqrt{\frac{K_1}{J}} \text{ [Hz]}$$

f_n = Resonance frequency [Hz]

K_1 = Gear torsional stiffness K_1 [Nm/rad]

J = Load moment of inertia [kgm²]

allows the calculation of the resonance frequency at the gear output from the given torsional stiffness, K_1 , of the Harmonic Drive[®] gear and the load's moment of inertia. The calculated frequency should correspond with the value provided in table 31.1. The higher the load's moment of inertia, the more influence the application has on the gear selection. If the moment of inertia = 0, the selected application has no numerical influence on the selection result.

Resonance Speed (Gear Input)

The resonance speed n_n on the input side (motor side) can be calculated using the formula

$$n_n = f_n \cdot 30 \text{ [rpm]}$$

During operation, we recommend that you pass the resonance speed rapidly. This can be achieved by selecting a suitable gear ratio. Another possibility is to select suitable gear stiffness such that the resonance speed lies beyond the required speed range.

Selection Example

HFUC-40-120-2A-GR preselected from "Selection Procedure" on page 28.

Intended application: milling head for woodworking

Moment of inertia at the gear output: 7 kgm². Recommended resonance frequency from table 31.1: ≥ 30 Hz.

Resonance frequency using the preselected gear

HFUC-40-120-2A-GR:

$$f_n = \frac{1}{2\pi} \sqrt{\frac{1.3 \cdot 10^5}{7}} = 22 \text{ [Hz]}$$

According to stiffness based dimensioning, this gear size is too small for the application.

The larger gear HFUC-50-120-2A-GR results in a resonance frequency of:

$$f_n = \frac{1}{2\pi} \sqrt{\frac{2.5 \cdot 10^5}{7}} = 30 \text{ [Hz]}$$

Based on stiffness based dimensioning, the gear HFUC-50-120-2A-GR is recommended.

The resonance speed at the input (motor) amounts to:

$$n_n = 30 \cdot 30 = 900 \text{ [rpm]}$$

Either, this speed should be passed without stopping when accelerating / braking, or it should lie beyond the utilised speed range.

4.2 Calculation of the Torsion Angle

Calculation of the Torsion Angle φ at Torque T:

Equation 33.1

$$T \leq T_1$$

$$\varphi = \frac{T}{K_1}$$

Equation 33.2

$$T_1 < T \leq T_2$$

$$\varphi = \frac{T_1}{K_1} + \frac{T - T_1}{K_2}$$

Equation 33.3

$$T > T_2$$

$$\varphi = \frac{T_1}{K_1} + \frac{T_2 - T_1}{K_2} + \frac{T - T_2}{K_3}$$

φ = Angle [rad]
 T = Torque [Nm]
 K = Stiffness [Nm/rad]

Example: HFUC-32-100-2UH

$$T = 60 \text{ Nm} \quad K_1 = 6.7 \cdot 10^4 \text{ Nm/rad}$$

$$T_1 = 29 \text{ Nm} \quad K_2 = 1.1 \cdot 10^5 \text{ Nm/rad}$$

$$T_2 = 108 \text{ Nm} \quad K_3 = 1.2 \cdot 10^5 \text{ Nm/rad}$$

$$\varphi = \frac{29 \text{ Nm}}{6.7 \cdot 10^4 \text{ Nm/rad}} + \frac{60 \text{ Nm} - 29 \text{ Nm}}{1.1 \cdot 10^5 \text{ Nm/rad}}$$

$$\varphi = 7.15 \cdot 10^{-4} \text{ rad}$$

$$\varphi = 2.5 \text{ arc min}$$

Equation 33.4

$$\varphi \text{ [arc min]} = \varphi \text{ [rad]} \cdot \frac{180 \cdot 60}{\pi}$$

4.3 Accuracy of the Oldham Coupling HFUS-250

Information concerning the Oldham coupling can be found in section 5.7.2.

In the region of tooth engagement Harmonic Drive® gears have no backlash. If an Oldham coupling is used for the compensation of eccentricity errors of the motor shaft, a small backlash in the range of a few seconds of arc can occur at the output shaft, as listed in table 33.5.

Table 33.5

Sizes		14	17	20	25	32	40	45	50	58
Ratio	30	60	33	28	28	23	-	-	-	-
	50	36	20	17	17	14	14	12	12	10
	80	23	13	11	11	9	9	8	8	6
	100	18	10	9	9	7	7	6	6	5
	120	-	8	8	8	6	6	5	5	4
	160	-	-	6	6	5	5	4	4	3

[arcsec]

4.4 Efficiency Versus Load

Efficiency for Harmonic Drive® gears varies depending on the output torque. The efficiency curves are for gears operating at rated output torque. Efficiency for a gear operating at a load below the rated torque may be estimated using a compensation curve and equation as shown on the next page.

4.4.1 Efficiency Calculations HFUS-2SO and HFUS-2SH Units

Table 34.1

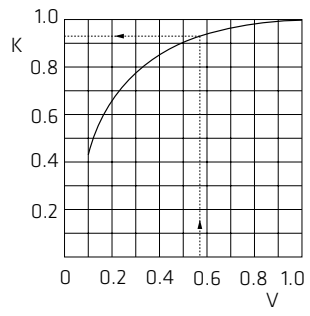
Calculation Procedure	Example
	Efficiency of HFUC-20-80-2A-GR with input speed $n=1000$ rpm output torque $T=19.6$ Nm at 20° C ambient temperature. Lubrication: Oil
The efficiency may be determined using the efficiency graphs.	From matching chart $\eta = 78\%$
Calculate the torque factor V .	$T_{av} = 19.6$ Nm $T_N = 34.0$ Nm
$V = \frac{T_{av}}{T_N} \quad \text{[Equation 34.2]}$ <p>With: T_{av} = Average torque T_N = Rated torque at rated speed</p>	$V = \frac{19.6 \text{ Nm}}{34.0 \text{ Nm}} = 0.57$
K depending on gear type and V , see illustration 34.4	
Efficiency $\eta_L = \eta \cdot K$ [Equation 34.3]	$\eta_L = 78 \cdot 0.93 = 73\%$

Calculating Factor K

Illustration 34.4

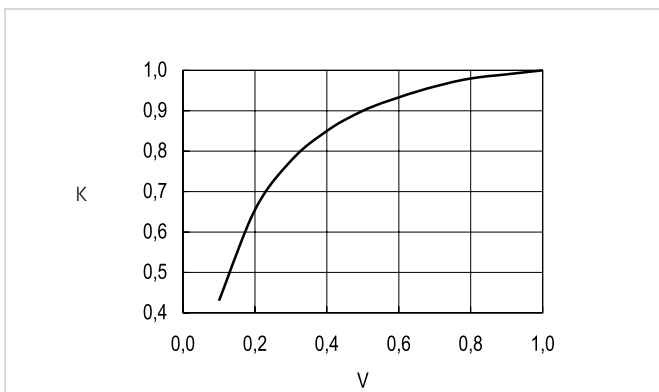

4.4.2 Efficiency Calculations HFUS-2UH

Calculation of total efficiency η_L

Equation 35.1

$$\eta_L = K \cdot (\eta_R + \eta_e)$$

with:

K = Correction factor from illustration 35.3

K = 1; for $T > T_N$

η_R = Efficiency at rated torque, see 36.1

η_e = Correction value to reflect the influence of the rotary shaft seals at the input side, see illustration 35.4

Calculation of torque factor V

Equation 35.2

$$V = \frac{T}{T_N}$$

with:

T = Actual torque

T_N = Rated torque at rated speed

Correction factor/value HFUS-2UH

Illustration 35.3

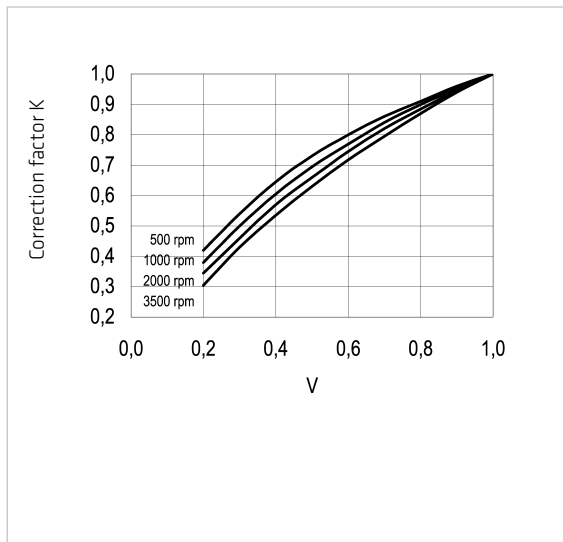
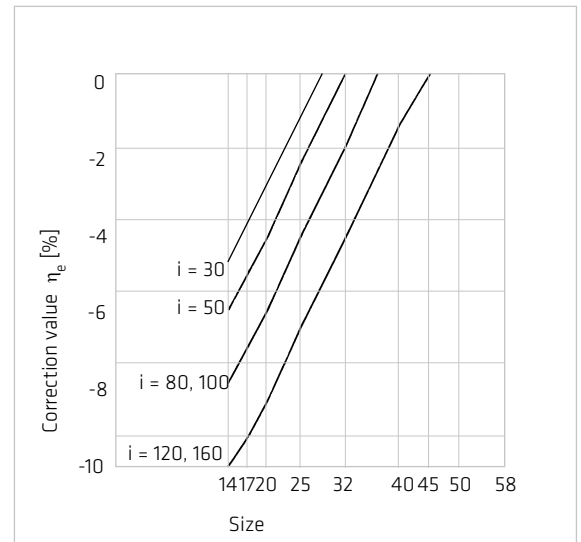

Illustration 35.4



4.4.3 Efficiency Tables

Grease Tables

Efficiency for Grease Lubrication at Rated Torque
Harmonic Drive® Grease

HFUS-2UH

Illustration 36.1

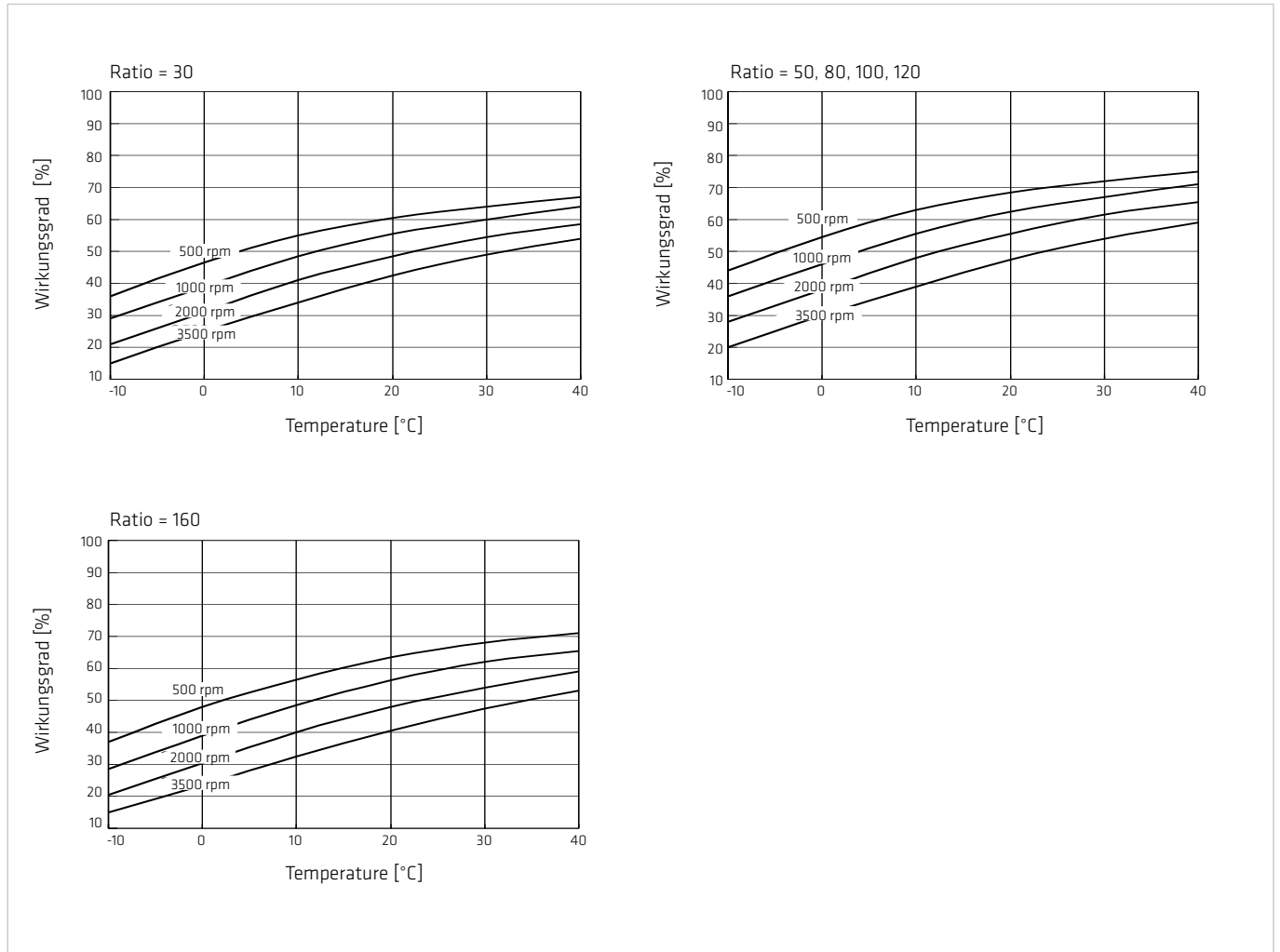

HFUS-250 and HFUS-25H

Size 14

Illustration 37.1

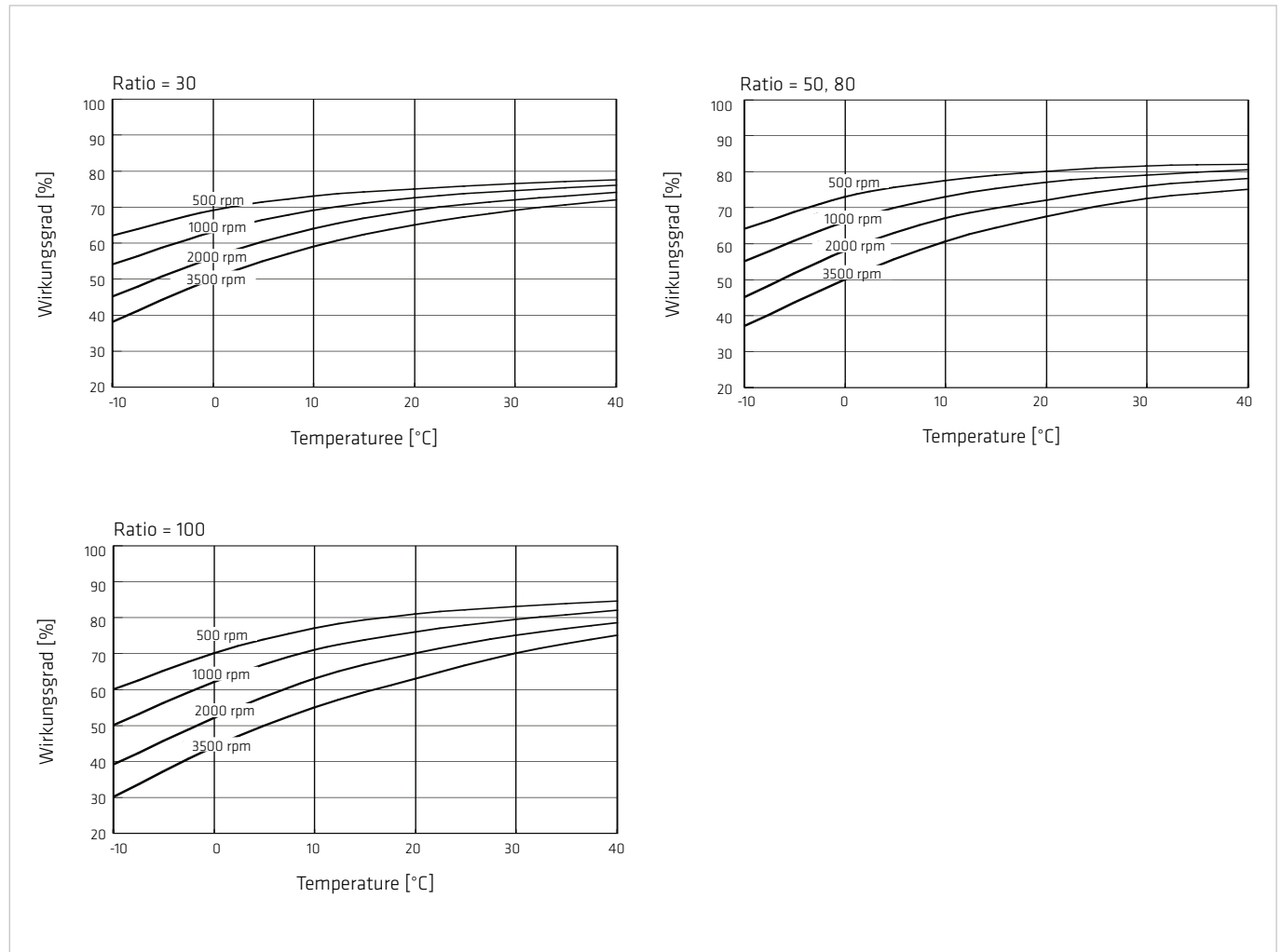
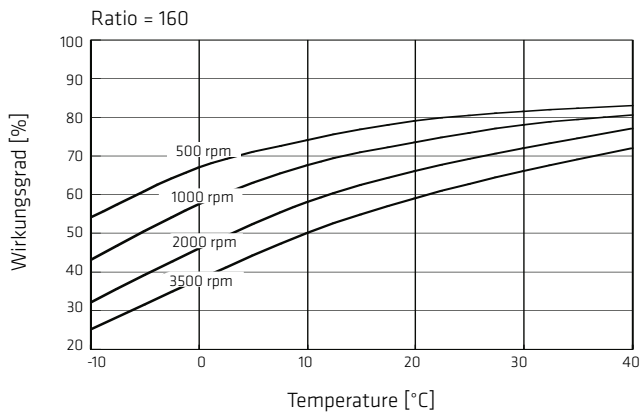
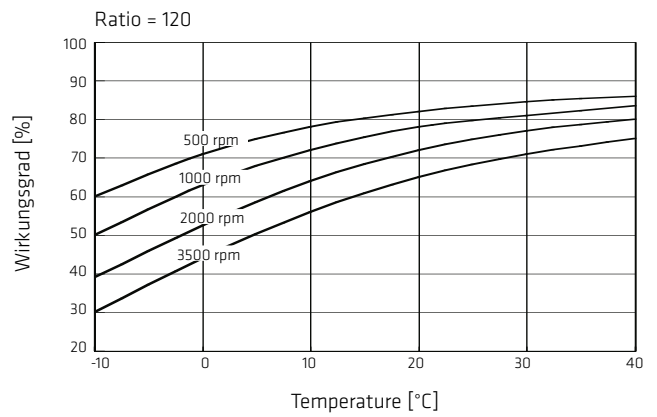
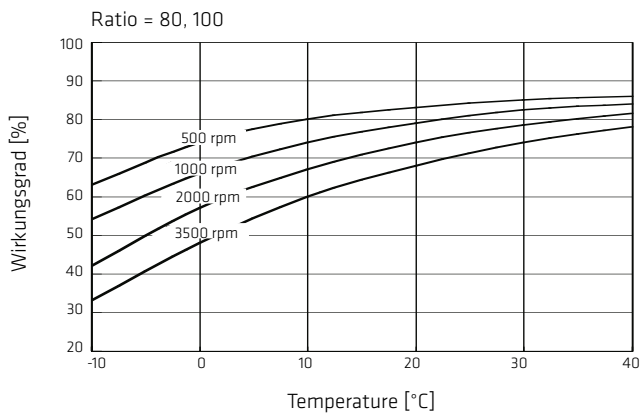
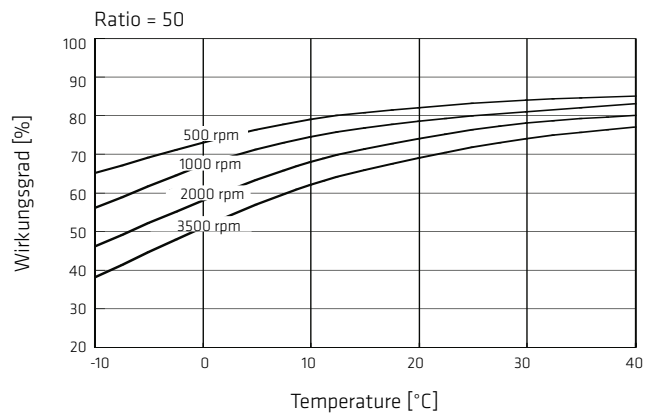
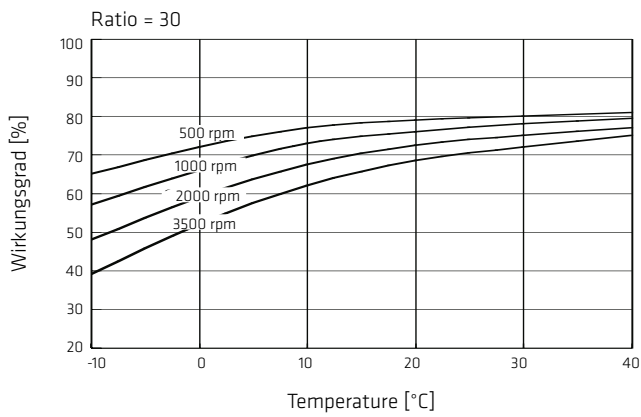

Illustration 38.1



4.5 No Load Starting, Back Driving and Running Torque

No Load Running Torque

The no load running torque is the torque required to maintain rotation of the input element (high speed side) at a defined input speed with no load applied to the output.

No Load Starting Torque

The no load starting torque is the quasistatic torque required to commence rotation of the input element (high speed side) with no load applied to the output element (low speed side).

No Load Back Driving Torque

The no load back driving torque is the torque required to commence rotation of the output element (low speed side) with no load applied to the input element (high speed side). The approximate range for no load back driving torque, based on tests of actual production gears, is shown in the matching table. In no case should the values given be regarded as a margin in a system that must hold an external load. Where back driving is not permissible a brake must be fitted.

4.5.1 No Load Running Torque

No Load Running Torque HFUS-2UH

Illustration 39.1

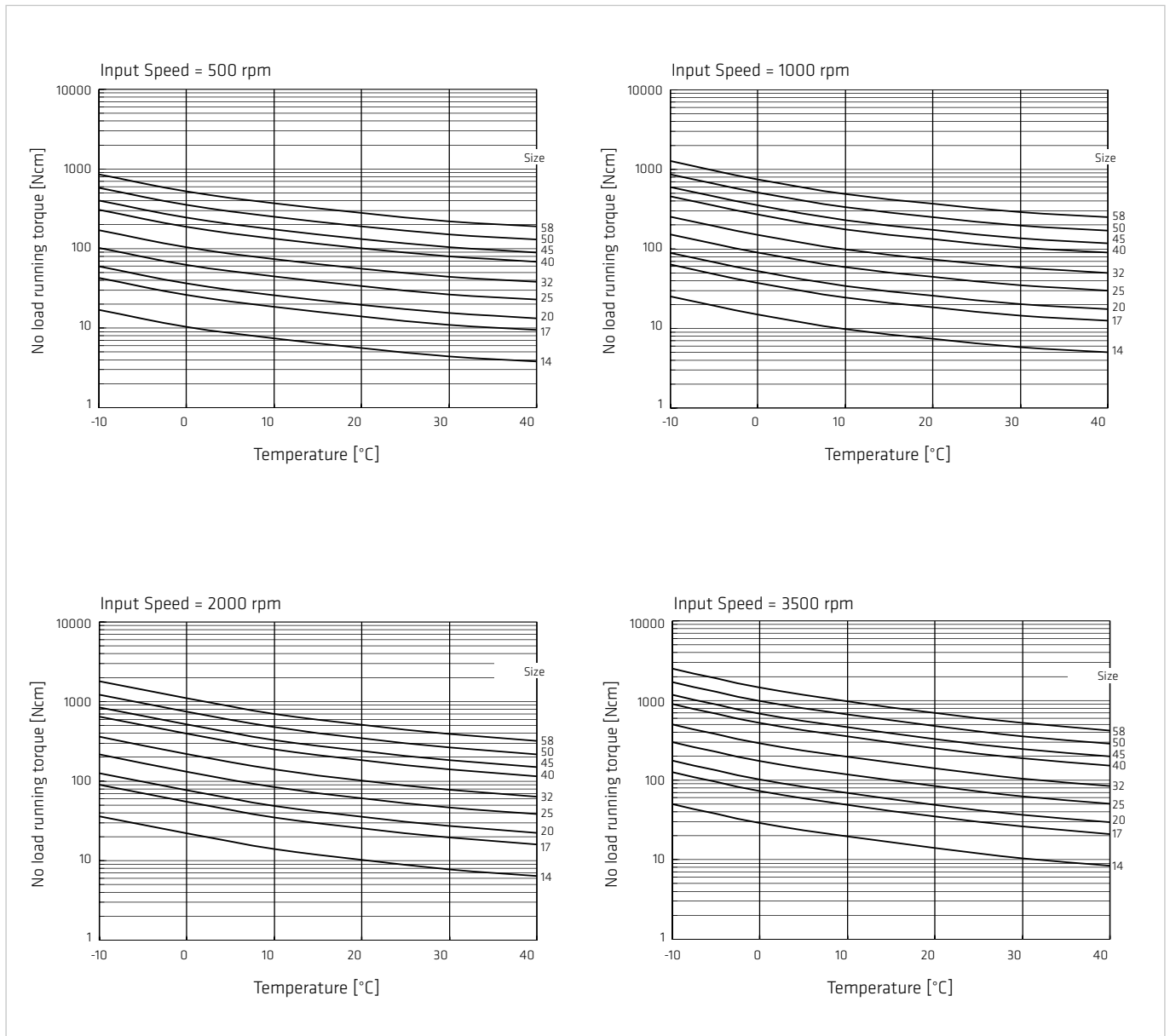

Compensation Values For No Load Running Torque HFUS-2UH

When using gears with ratios other than $i \neq 100$, please apply the compensation values from the table to the values taken from the curves

Table 40.1

[Ncm]

Ratio	Size								
	14	17	20	25	32	40	45	50	58
30	-	-	5.9	9.6	18.3	-	-	-	-
50	1.1	1.8	2.6	4.2	8.0	13.3	18.2	23.9	34.6
80	0.2	0.4	0.5	0.8	1.5	2.4	2.3	4.3	6.2
120	-	-0.2	-0.4	-0.6	-1.1	-1.7	-2.4	-3.1	-4.4
160	-	-	-0.8	-1.3	-2.5	-4.0	-5.5	-7.2	-10.3

No Load Running Torque HFUS-2SO and HFUS-2SH

Illustration 40.2

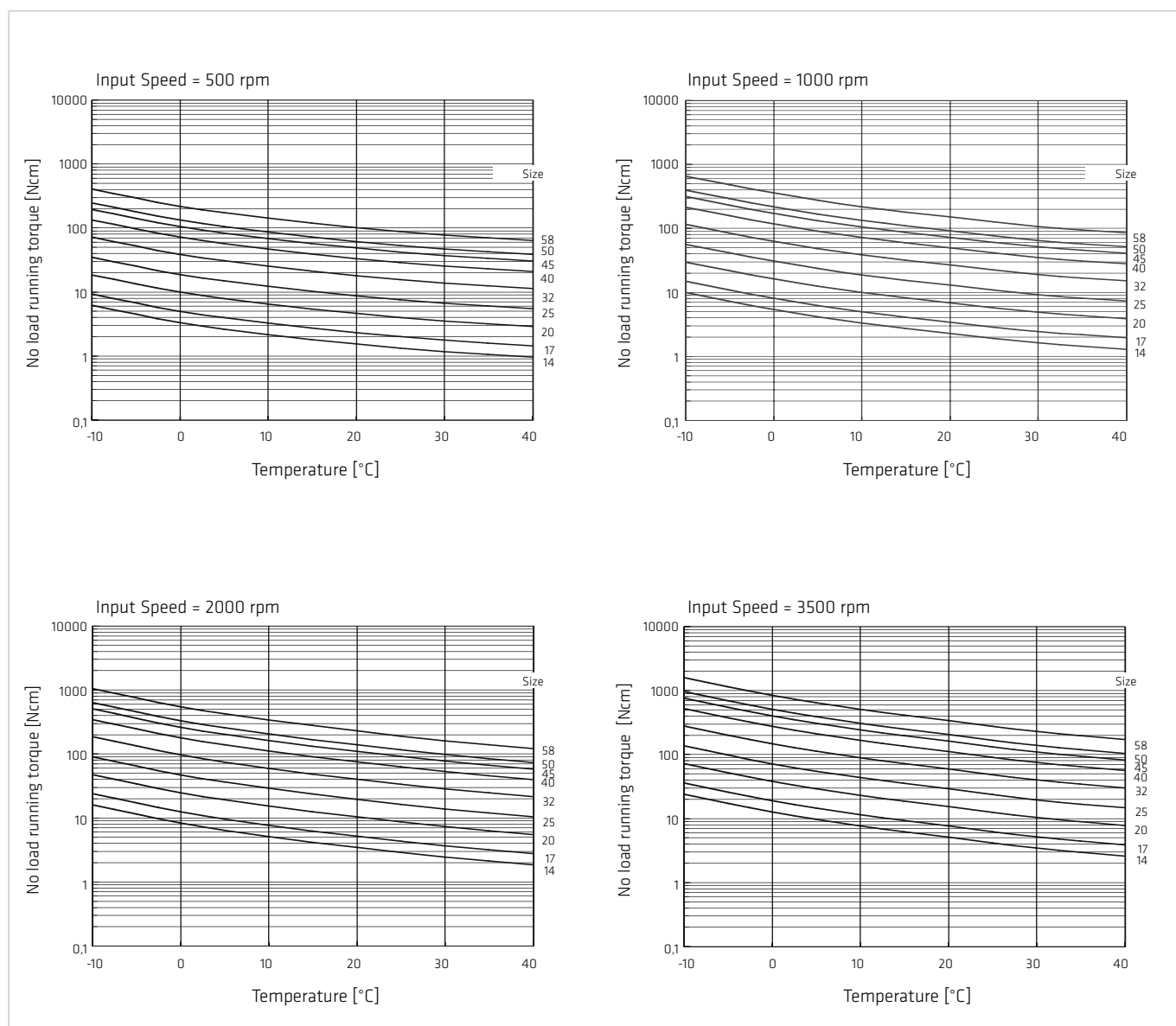

Compensation Values For No Load Running Torque HFUS-2SO and HFUS-2SH

Table 41.1

[Ncm]

Ratio	Size								
	14	17	20	25	32	40	45	50	58
30	1.1	1.8	2.7	5.0	10	-	-	-	-
50	0.5	0.8	1.2	2.2	4.5	8.0	11	15	22
80	0.1	0.1	0.2	0.3	0.7	1.2	1.7	2.3	3.4
120	-	-0.1	-0.1	-0.2	-0.5	-0.9	-1.3	-1.7	-2.5
160	-	-	-0.3	-0.6	-1.2	-2.2	-3.0	-4.0	-6.1

4.5.2 No Load Starting Torque

No Load Starting Torque HFUS-2UH

Table 41.2

[Ncm]

Ratio	Size								
	14	17	20	25	32	40	45	50	58
30	11	30	43	64	112	-	-	-	-
50	8.8	27	36	56	85	136	165	216	297
80	7.5	25	33	50	74	117	138	179	244
100	6.9	24	32	49	72	112	131	171	231
120	-	24	31	48	68	110	126	165	223
160	-	-	31	47	67	105	122	156	213

No Load Starting Torque HFUS-2SO and HFUS-2SH

Table 41.3

[Ncm]

Ratio	Size								
	14	17	20	25	32	40	45	50	58
30	4.3	6.5	11	19	45	-	-	-	-
50	3.3	5.1	6.6	12	26	46	63	86	130
80	2.4	3.3	4.1	7.7	16	29	41	54	82
100	2.1	2.9	3.7	6.9	15	26	36	48	73
120	-	2.7	3.3	6.3	13	24	33	45	67
160	-	-	2.9	5.5	12	21	29	39	58

4.5.3 No Load Back Driving Torque

No Load Back Driving Torque HFUS-2UH

Table 42.1

[Nm]

Ratio	Size								
	14	17	20	25	32	40	45	50	58
30	5.4	17	23	35	57	-	-	-	-
50	5.3	16	22	34	51	82	99	129	178
80	7.2	24	31	48	70	112	133	172	234
100	8.2	29	38	59	86	134	158	205	278
120	-	34	45	69	97	158	182	237	322
160	-	-	59	90	128	201	233	299	408

No Load Back Driving Torque HFUS-250 and HFUS-2SH

Table 42.2

[Nm]

Ratio	Size								
	14	17	20	25	32	40	45	50	58
30	2.0	3.2	5.5	10	21	-	-	-	-
50	1.4	2.5	4.0	7.5	16	28	37	52	80
80	1.4	2.5	4.2	7.7	16	28	39	53	81
100	1.7	2.8	4.5	8.4	18	31	42	57	88
120	-	3.1	4.9	9.2	19	34	47	63	97
160	-	-	5.8	11	23	40	57	77	120

4.6 Continuous Operation HFUS-2UH

The friction of the rotary shaft seals at the input side can result in an increased temperature of the hollow shaft units during operation. Therefore the defined “Limit for average input speed” of these units is reduced. For continuous operation at rated speed the max. operating times specified in table 43.2 should not be exceeded.

Alternatively a design according to illustration 43.1 can be used. This application example shows the removal of the rotary shaft seals at the (fast running) input side. For this design, the operating time is not limited. The removal of one or both rotary shaft seals at the input element should only be carried out if other measures have been undertaken to prevent the leakage of grease or oil, or if a leakage can be ruled out due to the installation position.

Illustration 43.1

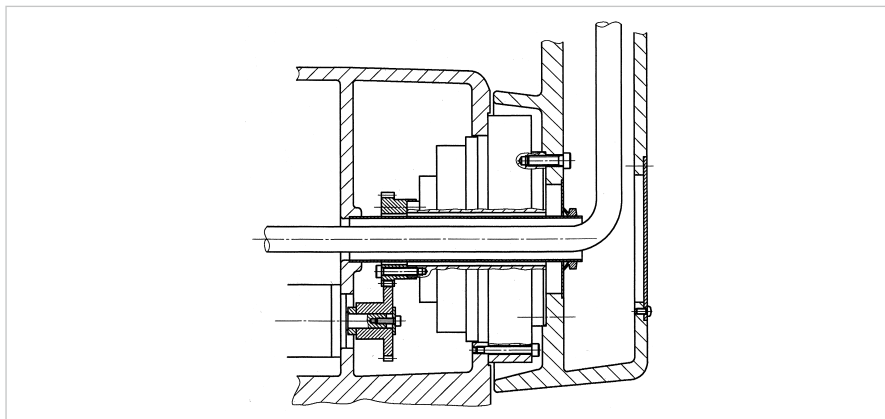

Max. Permissible Operating Time At Continuous Operation

Table 43.2

[min]

Operating time	Sizes								
	14	17	20	25	32	40	45	50	58
at no load	90	90	90	60	45	40	35	30	20
at rated torque	60	60	60	45	35	30	25	20	15

The data mentioned in table 43.2 are valid for:

- Ambient temperature: 25 °C
- Input speed: 2000 rpm
- Max. lubrication temperature: 80 °C
- Mounting of the unit on a plate with the following dimensions:
Height of plate: 330 mm
Thickness of plate: 15 mm for sizes ≤ 32
30 mm for sizes ≥ 40
- Plate material: Steel
- An additional output flange is not mounted.

4.7 Output Bearing Operating Life

The operating life of the output bearing can be calculated using equation 44.1.

Equation 44.1

$$L_{10} = \frac{10^6}{60 \cdot n_{av}} \cdot \left(\frac{C}{f_w \cdot P_c} \right)^B$$

with:

- L_{10} [h] = Operating life
- n_{av} [rpm] = Average output speed (equation 44.2)
- C [N] = Dynamic load rating see section 3.3.6
- P_c [N] = Dynamic equivalent load (equation 45.1)
- f_w = Operating factor (table 44.3)
- B = Bearing type (table 44.4)

Average Output Speed

Equation 44.2

$$n_{av} = \frac{|n_1| t_1 + |n_2| t_2 + \dots + |n_n| t_n}{t_1 + t_2 + \dots + t_n + t_p}$$

Table 44.3

Load conditions	f_w
No impact loads or vibrations	1 ... 1.2
Normal rotating, normal loads	1.2 ... 1.5
Impact loads and/or vibrations	1.5 ... 3

Table 44.4

Bearing type	B
Cross roller bearings	10/3
Four point contact bearings	3

Dynamic Equivalent Load

Equation 45.1

$$P_c = x \cdot \left(F_{rav} + \frac{2M}{d_p} \right) + y \cdot F_{aav}$$

with:

F_{rav} [N] = Radial force (equation 45.2)

x = Radial load factor (table 45.4)

F_{aav} [N] = Axial force (equation 45.3)

y = Axial load factor (table 45.4)

d_p [m] = Pitch circle (see section 3.3.5)

M = Tilting moment

Equation 45.2

$$F_{rav} = \left(\frac{|n_1| \cdot t_1 \cdot (|F_{r1}|)^B + |n_2| \cdot t_2 \cdot (|F_{r2}|)^B + \dots + |n_n| \cdot t_n \cdot (|F_{rn}|)^B}{|n_1| \cdot t_1 + |n_2| \cdot t_2 + \dots + |n_n| \cdot t_n} \right)^{1/B}$$

Equation 45.3

$$F_{aav} = \left(\frac{|n_1| \cdot t_1 \cdot (|F_{a1}|)^B + |n_2| \cdot t_2 \cdot (|F_{a2}|)^B + \dots + |n_n| \cdot t_n \cdot (|F_{an}|)^B}{|n_1| \cdot t_1 + |n_2| \cdot t_2 + \dots + |n_n| \cdot t_n} \right)^{1/B}$$

Table 45.4

Load factors	x	y
$\frac{F_{aav}}{F_{rav} + 2 \cdot M / d_p} \leq 1.5$	1	0.45
$\frac{F_{aav}}{F_{rav} + 2 \cdot M / d_p} > 1.5$	0.67	0.67

Illustration 45.5

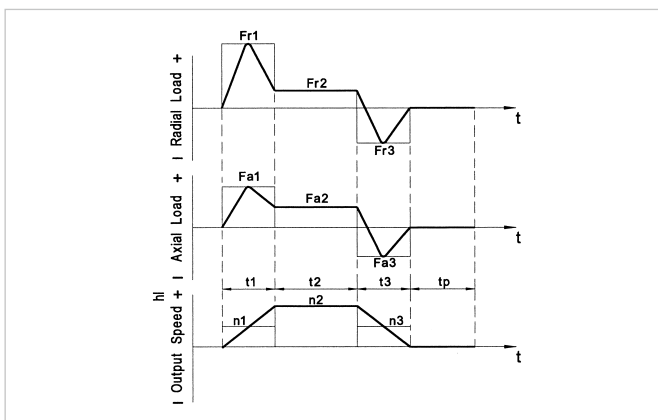

Please note:

F_{rx} = represents the maximum radial force.

F_{ax} = represents the maximum axial force.

t_p = represents the pause time between cycles.

4.7.1 Output Bearing at oscillating motion

Life for Oscillating Motion

The operating life at oscillating motion can be calculated using equation 46.1

Equation 46.1

$$L_{oc} = \frac{10^6}{60 \cdot n_1} \cdot \frac{180}{\varphi} \cdot \left(\frac{C}{f_w \cdot P_c} \right)^B$$

with:

L_{oc} [h] = Operating life for oscillating motion

n_1 [cpm] = Number of oscillations/minute*

C [N] = Dynamic load rating, see table "Output Bearing" in the appropriate product chapter (table 21.1)

P_c [N] = Dynamic equivalent load (equation 45.1)

φ [deg] = Oscillating angle

f_w = Operating factor (table 44.3)

* one oscillation means 2φ

Oscillating Angle

At oscillating angles $< 5^\circ$ fretting corrosion may occur due to insufficient lubrication. In this case please contact our sales engineer for counter measures.

Illustration 46.2

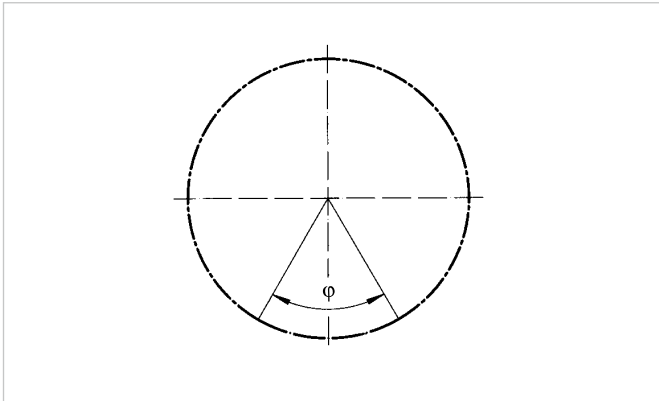

4.8 Permissible Static Tilting Moment

In case of static load, the bearing load capacity can be determined as follows:

Equation 47.1

$$f_s = \frac{C_0}{P_0} \text{ mit } P_0 = x_0 \left(F_r + \frac{2M}{d_p} \right) + y_0 \cdot F_a$$

and so

Equation 47.2

$$M_0 = \frac{d_p \cdot C_0}{2 \cdot f_s}$$

f_s = Static load safety factor

($f_s = 1.5 \dots 3$) (table 47.3)

C_0 = Static load rating

$F_r = F_a = 0$

$x_0 = 1$

$y_0 = 0.44$

P_0 = Static equivalent load (equation 47.1)

d_p = Pitch circle diameter of the output bearing (section 3.3.6)

M = Moment acting

M_0 = Allowable static overturning moment

Table 47.3

Rotation conditions of bearing	Lower limit value for f_s
Normal	≥ 1.5
Vibrations / Impacts	≥ 2
High transmission accuracy	≥ 3

4.9 Angle of Inclination

The angle of inclination of the output flange, as a function of the tilting moment acting on the output bearing, can be calculated by means of equation 47.4:

Equation 47.4

$$\gamma = \frac{M}{K_B}$$

with:

γ [arcmin] = Angle of inclination of the output flange

M [Nm] = Tilting moment acting on the output bearing

K_B [Nm/arcmin] = Moment stiffness of the output bearing (table 21.1)

4.10 Lubrication

Ratings and Lubricants

Harmonic Drive® products achieve the specified ratings and characteristics in the standard ambient temperature range (0° C to 40° C) when they are used with the lubricants named in the catalogue. Harmonic Drive AG can guarantee for the data specified in the catalogue only if a Harmonic Drive® grease or a mineral oil qualified for the specific product used. Lubricants and lubricant quantities other than recommended by Harmonic Drive AG should be qualified by means of prototype tests, as necessary.

The warranty becomes void when lubricants that have not been recommended in the Harmonic Drive® catalogue or that have not been approved in writing for the specific application are used.

4.10.1 Grease Lubrication

Application of Harmonic Drive® Lubricating Grease

Depending on product, size and if necessary ratio, the matching Harmonic Drive® grease should be selected.

Caution!

The Harmonic Drive® high performance 4BNo.2 grease becomes relatively thin during operation. Therefore the design must be oil-tight. Because of the special characteristics of this grease, a small base oil leakage at the oil seals can not completely be ruled out.

Table 48.1

Grease	Ratio ≥ 50														
	Size														
	8	11	14	17	20	25	32	40	45	50	58	65	80	90	100
Flexolub A1	-	Standard for CPU and CobaltLine													
SK-1A	-			Standard											
SK-2	Standard			-											
4BNo.2	-	For heavy duty operation*													

Table 48.2

Grease	Ratio = 30						
	Size						
	8	11	14	17	20	25	32
Flexolub A1	-		Standard for CPU				
SK-1A	-				Standard		
SK-2	Standard				-		
4BNo.2	-				For heavy duty operation*		

Notes:

* = recommended for heavy duty operation or at operating temperatures ranging from -10° C to +110° C

- = not approved

Table 49.1 gives some important information regarding Harmonic Drive® lubricating greases.

Table 49.1

Type	Harmonic Drive® lubricating greases			
	Standard		Special	
	SK-1A	SK-2	Flexolub A1	4BNo.2
Operating temperature range	0° C ... +80° C	0° C ... +80° C	-40° C ... +120° C	-10° C ... +110° C
Base oil	Mineral oil	Mineral oil	PAO / Ester oil	Synthetic oil
Thickener	Lithium soap	Lithium soap	Lithium soap	Urea
Consistency class (NLGI)	2	2	1	1-2
Base oil viscosity (40° C; 100° C)	37; 5,9 mm ² /St	37; 5,9 mm ² /St	25; 5,2 mm ² /St	50; 12 mm ² /St
Drop point	197° C	198° C	180° C	247° C
Colour	yellow	green	magenta	pale yellow
Max. storage time in hermetically sealed container	5 years			
Ease of sealing (safety against grease- or base oil leakage at the oil seals)	+	+	+	+/-

Notes:

+ = Good

+/- = May be critical depending on design / mounting position / application, please contact Harmonic Drive AG

Safety data sheets and technical data sheets for the Harmonic Drive® lubricants are available from Harmonic Drive AG.

Special Operating Demands

Table 50.1 shows examples of lubricants for special operating demands. In individual cases other lubricants may be recommendable, and special limit values may have to be considered for product calculations at extended operating temperatures. Please ask Harmonic Drive AG for more information.

Table 50.1

Lubricants for special operating demands			
Application	Type	Manufacturer, Designation	Operating temperature range ¹⁾
Broadband temperature range	Grease	Harmonic Drive®, Flexolub-A1	-40° C ... +120° C ³⁾
Low temperature	Grease Oil	Harmonic Drive®, Flexolub-M0	-50° C ... +120° C ²⁾⁵⁾
High temperature	Grease Oil	Mobil, Mobil Grease 28 Mobil, Mobil SHC 626	-55° C ... +160° C ²⁾ -15° C ... +140° C ²⁾
Food-/pharmaceutical industry	Grease	Bechem, Berulub FG-H 2 SL	-40° C ... +120° C ²⁾⁴⁾

Notes:

- ¹⁾ Operating temperature = Lubricant temperature
- ²⁾ User specific prototype tests recommended
- ³⁾ Applicability confirmed for all Harmonic Drive® catalogue products with cup type Flexspline for size 14 and up. 1 kg bundles available at HDAG
- ⁴⁾ NSF-H1 certification. Applicability confirmed for HFUC-XX, CPU-XX, HFUS-XX, CPL-XX, CHA-XX with i=100 at full usage of the catalogue performance data. Please consult Harmonic Drive AG for i>100 applications. For food/ pharmaceutical compatibility, grease change is necessary for output- and support bearings, if used. 400 g bundles available at Harmonic Drive AG.
- ⁵⁾ Recommended for applications requiring best possible efficiency at low temperatures. Not suitable for high output torque.

4.10.2 Oil Lubrication

Harmonic Drive® units with oil lubrication are customer specific solutions. Oil quantity and change interval are specified individually.

Table 50.2

Shared lubricating oils				
Manufacturer	Klüber	Mobil	Castrol	Shell
Designation	Syntheso D 68 EP	Mobilgear 600 XP 68	Optigear BM 68	Omala S2 G 68

Please note the information in section 5.5.5.

4.11 Axial Forces at the Wave Generator HFUS-250 and HFUS-25H

When a Harmonic Drive® Gear is used as a speed reducer (torque input via Wave Generator), the deflection of the Flexspline leads to an axial force acting on the Wave Generator. This axial force acts in the direction of the Flexspline diaphragm. When the Harmonic Drive® Component Set is used as a speed accelerating gear (reverse operation, e.g. when braking), the axial force acts in the opposite direction. In any case the axial force must be absorbed by the input shaft (motor shaft). The Wave Generator thus needs to be fixed on the input shaft in the axial direction. In closed Harmonic Drive® units and gearboxes the axial force is absorbed internally.

Illustration 51.1

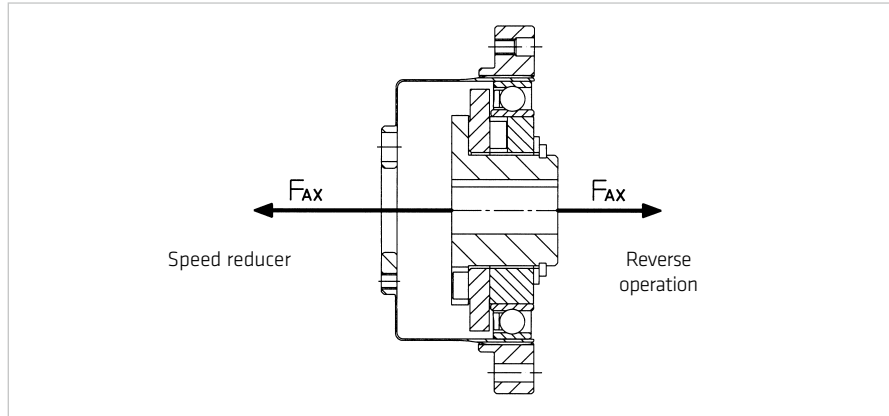

Table 51.2

Ratio		
30	$F_{AX} = 2 \cdot \frac{T}{D} \cdot \mu \cdot \tan 32^\circ$	[Equation 51.3]
50	$F_{AX} = 2 \cdot \frac{T}{D} \cdot \mu \cdot \tan 30^\circ + 2\mu PF$	[Equation 51.4]
80...160	$F_{AX} = 2 \cdot \frac{T}{D} \cdot \mu \cdot \tan 20^\circ + 2\mu PF$	[Equation 51.5]

with:

- F_{AX} = Axial force [N]
- D = (Size) · 0.00254 [m]
- T = Torque at the output [Nm]
- μ = 0.07 Coefficient of friction
- $2\mu PF$ = Additional force (only CSD) [N]

Example

Size 32 (CSD-32-50)
 Output torque = 300 Nm
 Coefficient of friction $\mu = 0.07$

$$F_{AX} = 2 \cdot \frac{200 \text{ Nm}}{(32 \cdot 0.00254) \text{ m}} \cdot 0.07 \cdot \tan 30^\circ + 16$$

$$F_{AX} = 215 \text{ N}$$

Table 51.6

Sizes	14	17	20	25	32	40	50
$2\mu PF$ [N] for CSD and SHD	2.1	4.1	5.6	9.8	16	24	39

5. Installation and Operation

5.1 Transport and Storage

Gears should be transported in the original packaging. If the gear is not put into service immediately on receipt, it should be stored in a dry area in the original packaging. The permissible storage temperature range is -20° C to +60° C.

5.2 Gear Condition at Delivery

The gears are generally delivered according to the dimensions indicated in the confirmation drawing.

Gears with Grease Lubrication

Units are supplied with grease lubricant as standard.

Gears with Oil Lubrication

Harmonic Drive® Units with oil lubrication are generally customer-specific solutions. Please follow the notes given on the confirmation drawing. The oil temperature during operation must not exceed 90° C. Oil must be filled into the unit by the customer as the standard delivery does not include any oil lubricant.

Oil Quantity

The values specified in the confirmation drawing include the valid oil quantities to fill in. The oil quantity defined on the confirmation drawing must be obeyed in any case. Too much oil results in excessive heat production and early wear due to the thermal destruction of the oil. If the oil level is too low, this may lead to early wear as a result of lubricant deficiency.

5.3 Assembly Information

ADVICE

Screws which have been tightened by the gear manufacturer must not be loosened.

5.4 Recommended Tolerances for Assembly HFUS-250 and HFUS-25H

In order for the full features of Harmonic Drive® Units to be exploited fully, it is essential that the tolerances according to table 53.2 are observed for the input assembly.

Illustration 53.1

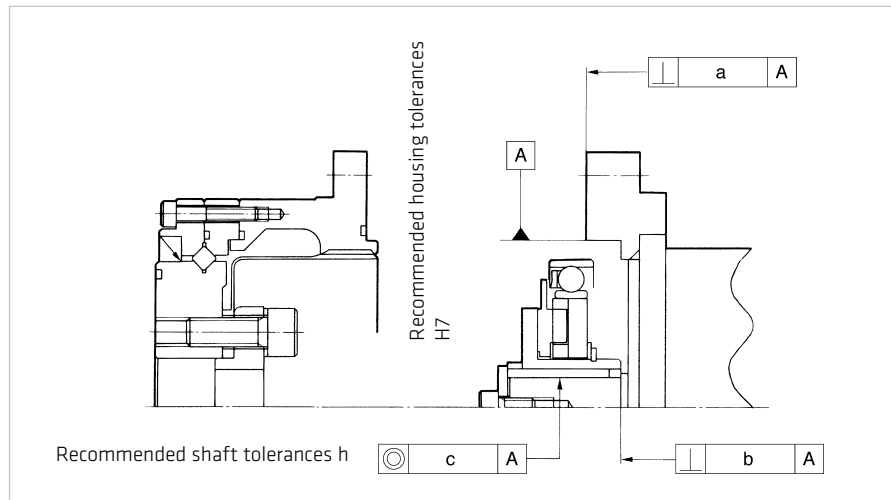

Table 53.2

[mm]

Size	14	17	20	25	32	40	45	50	58	65	80	90
a	0.011	0.015	0.017	0.024	0.026	0.026	0.027	0.028	0.031	0.034	0.043	0.050
b	0.017 (0.008)	0.020 (0.010)	0.020 (0.010)	0.024 (0.012)	0.024 (0.012)	0.032 (0.012)	0.032 (0.013)	0.032 (0.015)	0.032 (0.015)	0.032 (0.015)	0.036 (0.015)	0.036 (0.015)
c	0.030 (0.016)	0.034 (0.018)	0.044 (0.019)	0.047 (0.022)	0.050 (0.022)	0.063 (0.024)	0.065 (0.027)	0.066 (0.030)	0.068 (0.033)	0.070 (0.035)	0.090 (0.043)	0.091 (0.046)

The values in brackets are the recommended tolerances for component sets featuring a Wave Generator without Oldham coupling. The Oldham coupling serves to compensate for eccentricity of the input shaft and is available in the standard version. For the direct mounting of a Wave Generator without Oldham coupling (optional) on a motor shaft, the shaft tolerances should fulfill the DIN 42955 R standard.

5.5 Lubrication

Harmonic Drive® Units are delivered ready for immediate installation. They are supplied with lifetime lubricant which is a high performance grease that meets the specific requirements of the Harmonic Drive® gears. It guarantees constant accuracy of the gears for their whole life. A re-lubrication of the Units is not necessary.

5.5.1 Grease Lubrication HFUS-2SO and HFUS-2SH

We recommend the use of Harmonic Drive® greases which have been specially developed for use with sizes 14 to 100. When using these special greases continuous operation is permissible. However, under extreme operating conditions e.g. severe output side machine vibration (e.g. in the fabric take up of weaving machines) we recommend oil lubrication.

5.5.2 Amount of Grease HFUS-2SO and HFUS-2SH

Standard Units are prepared for grease lubrication. If no special arrangements are made the specially developed high performance grease SK-1A (for sizes 20 to 65) and SK-2 (for size 14 and 17) are used. If any other grease is used this will be indicated on the customer drawing. High performance 4BNo. 2 grease with improved characteristics is also available for these products. On delivery, Flexspline and Circular Spline teeth are lubricated ready for use. Before mounting, the Wave Generator bearing and the inner part of the Flexspline must be greased. It may be necessary to place an additional amount of grease on the front face of the Wave Generator (see illustration 55.2).

Illustration 54.1 shows the areas requiring grease.

Illustration 54.1

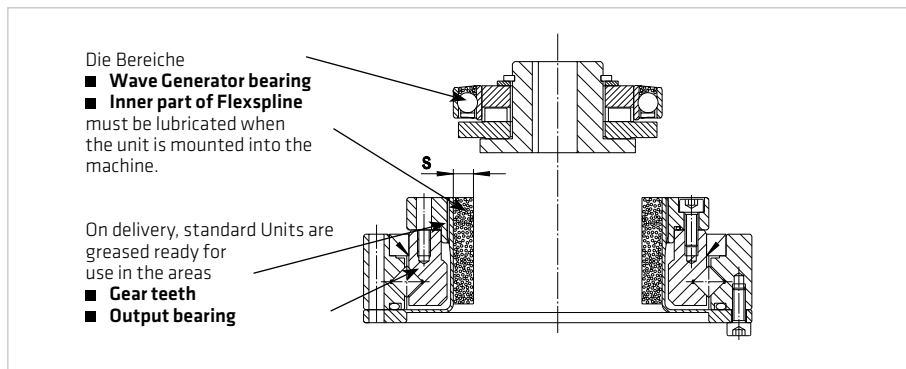
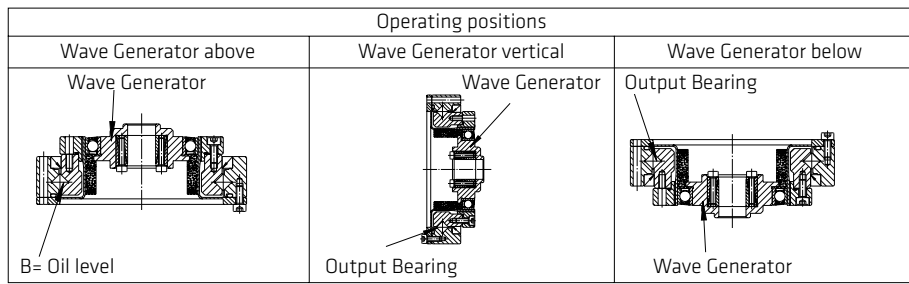

Table 54.2

Size		14	17	20	25	32	40	45	50	58	65
Dimensions S (s. illustration 54.1) [mm]		3	4	5	6	8	10	11	12	14	16
Total weight ca. [g]	Wave Generator mainly vertical or below	7	12	18	35	70	125	190	240	380	500
	Wave Generator mainly above	10	16	27	48	92	169	250	310	500	640
Total volume ca. [cm ³]	Wave Generator mainly vertical or below	8	13	20	39	77	138	210	265	420	550
	Wave Generator mainly above	11	18	30	53	100	186	275	340	550	700
Standard Harmonic Drive® grease		SK-2		SK-1A							

The following operating positions “Wave Generator above” or “Wave Generator below” refer to the position of the Wave Generator in relative to the output bearing of the Unit, see illustration 55.1.

Illustration 55.1



5.5.3 Additional Grease Package

The required grease quantity is dependent on the operating position. If the unit is mainly operated with Wave Generator above, additional grease must be supplied above the Wave Generator, see illustration 55.1 and table 54.2

Illustration 55.2

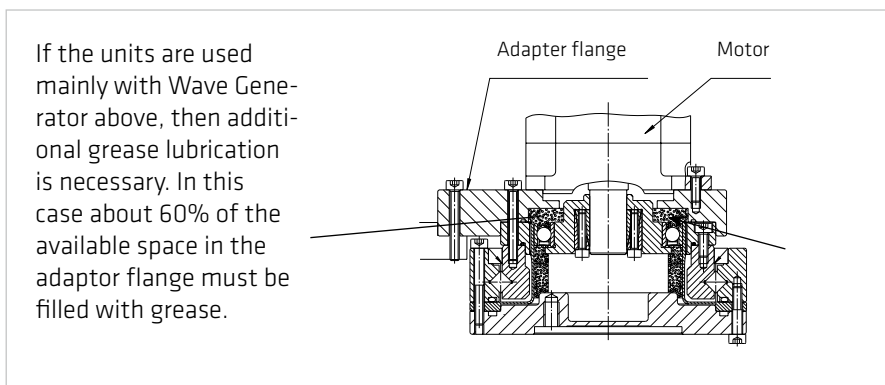

5.5.4 Grease Change

To change the grease the component set should be completely disassembled and cleaned before regreasing. Fresh grease should be applied generously to the inside of the Flexspline, the Wave Generator bearing, the Oldham coupling and the teeth of the Circular Spline and Flexspline.

In illustration 55.3, the grease change interval depending on the grease temperature is given. The number of allowable revolutions of the input shaft which represents the grease change interval can be estimated as shown in the example. This means, that for a temperature of SK-1A or SK-2 grease of 40° C a change should take place after approx. 8.5×10^8 revolutions of the input shaft. All grease change data refers to rated speed and rated torque.

Illustration 55.3

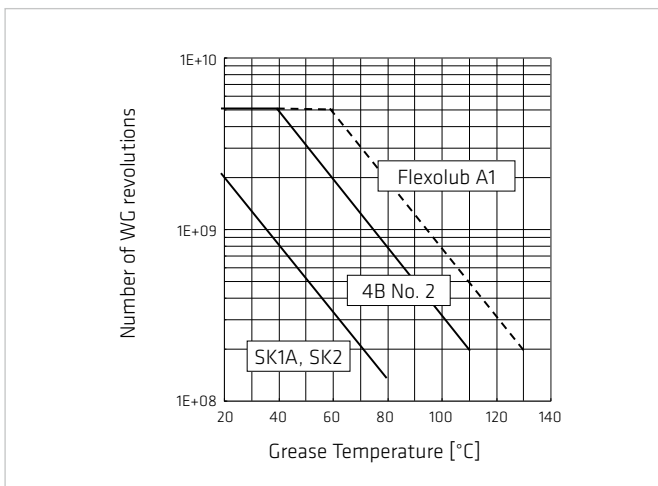

Equation 55.4

$$L_{CT} = L_{CTn} \cdot \left(\frac{T_r}{T_{av}} \right)^3$$

L_{CT} = Number of Wave Generator revolutions until grease change

L_{CTn} = see diagram

T_r = Rated torque

T_{av} = Average torque

5.5.5 Oil Lubrication

Harmonic Drive® Units with oil lubrication are generally customer-specific solutions. Please follow the notes given on the confirmation drawing and refer to page 54 for allowed oil types. The oil temperature during operation must not exceed 90° C. The minimum requirement is mineral oil CLP 68 (ISO VG 68) according to DIN 51517 T3. Oil must be filled into the unit by the customer as the standard delivery does not include any oil lubricant.

The values specified in the confirmation drawing include the required oil quantities. The oil quantity defined on the confirmation drawing must be obeyed in any case. Too much oil results in excessive heat production and early wear due to the thermal destruction of the oil. If the oil level is too low, this may lead to early wear as a result of lubricant deficiency.

The first oil change should be performed after about 100 hours of operation. Subsequent change intervals depending on the load, but should be carried out in a period of about 1000 hours.

To change the oil, the old oil must be completely drained and new oil introduced. The mixture of lubricants with different specifications is to be avoided. See table 50.2 for additional information.

5.6 Assembly

Assembly preparation

The gear assembly must be carried out very carefully and within a clean environment. Please make sure that during the assembly procedure no foreign particles enter the gear.

General information

Clean, degrease and dry all mating surfaces to ensure an adequate coefficient of friction. The values given are valid for 12.9 quality screws which must be tightened by means of a torque wrench. Locking devices such as spring washers or toothed washers should not be used.

Auxiliary materials for assembly

For the assembly, we recommend the application of the following auxiliary materials or the use of those with similar characteristics. Please pay attention to the application guidelines given by the manufacturer. Auxiliary materials must not enter the gear.

Surface sealing

- Loctite 5203
- Loxeal 28-10

Recommended for all mating surfaces, if the use of o-ring seals is not intended. Flanges provided with O-ring grooves must be sealed with sealing compound when a proper seal cannot be achieved using the O-ring alone.

Screw fixing

- Loctite 243

This adhesive ensures that the screw is fixed and also provides a good sealing effect. Loctite 243 is recommended for all screw connections.

Assembly paste

- Klüber Q NB 50

Recommended for o-rings which may come out of the groove during the assembly procedure. Before starting with the assembly you should spread some grease (which you can take from the gear) on all other o-rings.

Adhesives

- Loctite 638

Apply Loctite 638 to the connections between motor shaft and Wave Generator. You should make use of it only if this is specified in the confirmation drawing.

5.7 Mounting HFUS-2SO and HFUS-2SH Units

The following explanations refer to HFUS-2SO series units, having a Wave Generator with Oldham Coupling or a Solid Wave Generator.

The assembly of the HFUS-2SH series units with hollow shaft is not described explicitly in this manual. Please contact Harmonic Drive AG if necessary.

The assembling method of the gear depends strongly on the design details. Thus, this assembly manual only provides general guidelines. The assembly procedure may differ from those described herein in exceptional cases.

If the described assembling sequence cannot be observed, please ask Harmonic Drive® whether in the concrete case another sequence is permissible.

The assembly must take place without the use of undue force. The assembly instructions of the machine manufacturer should be referred to. Unless otherwise noted, all screws must be tightened crosswise in 3 steps to the prescribed torque.

Screws that have been tightened on delivery must not be released. On delivery, Flexspline and Circular Spline of HFUS-2SO and HFUS-2SH Units are pre-assembled only by a few screws. Therefore the full output bearing and torque load can only be applied after the unit has been attached completely to the machine frame and the load. Therefore we recommend the user to connect the unit to the machine housing and load (please take care of the dead weight) before initiating/ applying any radial and/ or axial forces.

5.7.1 Motor Assembly HFUS-250

Assembly of the adaptor flange to the motor

For the planning of the assembly sequence it may be helpful to know the max. diameter of the Wave Generator, see illustration 58.1. In table 58.2 the diameters of the Wave Generator main axes are indicated.

Illustration 58.1

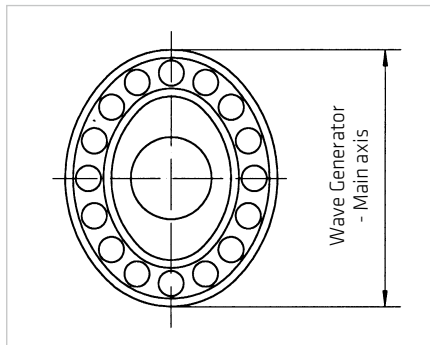
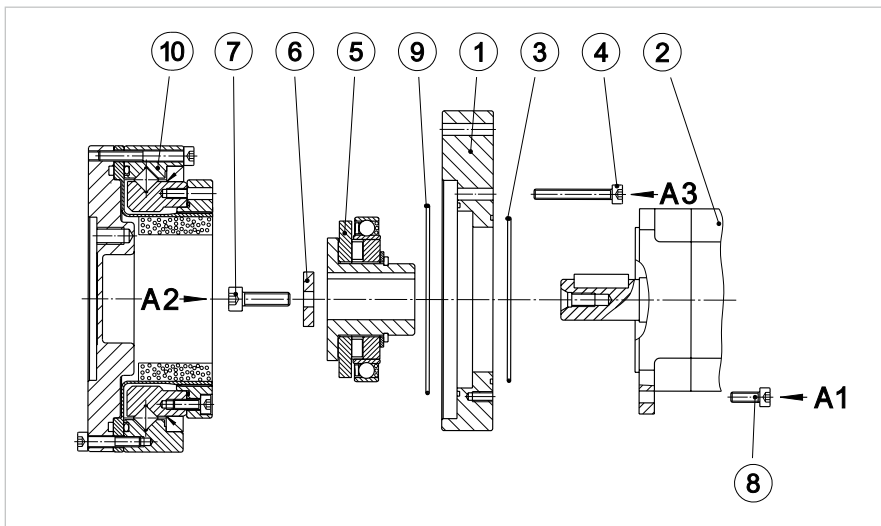

Table 58.2

Size	14	17	20	25	32	40	45	50	58
ca. Ø Wave Generator - Main axis	36	43	50	63	82	100	114	125	146

Connect the adaptor flange (1) to the motor (2) by means of the screws (8). Apply sealing to the motor flange, if necessary.

Illustration 58.3



5.7.2 Wave Generator Components HFUS-250

Illustration 59.1 shows a standard Wave Generator with Oldham Coupling.

Illustration 59.1

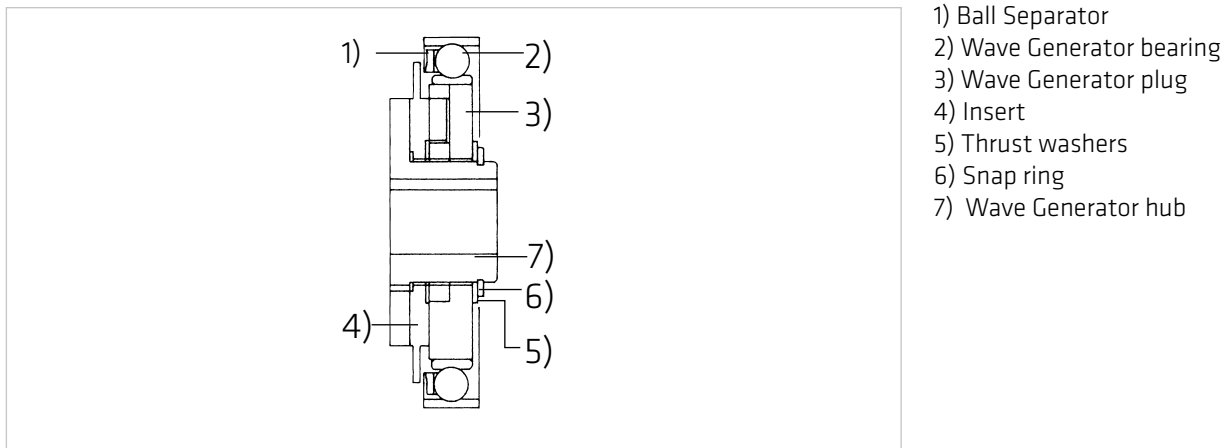

5.7.3 Mounting the Wave Generator (WG) to the Motor Shaft

The axial position of the Wave Generator in the gearbox is critical for the correct operation of the unit. Please check the correct position of the Wave Generator against the confirmation drawing.

- Push the greased Wave Generator onto the motor shaft according to the assembly dimension given in the confirmation drawing. If there is no assembly value given, the Wave Generator must be moved until it reaches the shaft collar.
- Insert the plug into the bore of the Wave Generator hub and tighten with the screw. When a clamping element is used, tighten its screws in five steps to the torque given in the confirmation drawing, see also illustration 59.1

5.7.4 Check before Assembly of the Wave Generator (WG)

- Final check of position of the Wave Generator. For some clamping elements an axial movement may occur during tightening. Please take account of this effect when positioning the Wave Generator on the shaft.
- Check whether the WG is lubricated. When the gear is oil lubricated, fill in the prescribed oil quantity.

5.7.5 Assembly of the Wave Generator (WG) into the Flexspline (FS)

When the Wave Generator is assembled into the Flexspline please consider that the parts must not be tilt during assembly. By parallel assembly it is ensured that the teeth of Flexspline and Circular Spline mesh symmetrically.

Alternatively the assembly can be executed during slowly rotation of the input shaft ($n < 10$ rpm). This method eases the assembly.

5.7.6 Assembly Control HFUS-2SO and HFUS-2SH

Very rarely, an eccentric tooth mesh, called dedoidal, may occur.

The correct assembly can be checked as follow:

- Check the running behaviour by rotating the input shaft (in case of types with input shaft). Alternatively you may rotate the output flange. If you notice torque variations these may be caused by eccentric tooth mesh.
- Check the running behaviour and the motor current while the motor is rotating. Strong fluctuations in the motor current and/or an excessive no-load current may be the result of an eccentric tooth mesh.

In case of a dedoidal assembly you can avoid permanent damage to the gear if the wrong installation is recognized by means of the above mentioned inspection. The problem can be solved by disassembling the gear followed by a new assembly.

Illustration 60.1

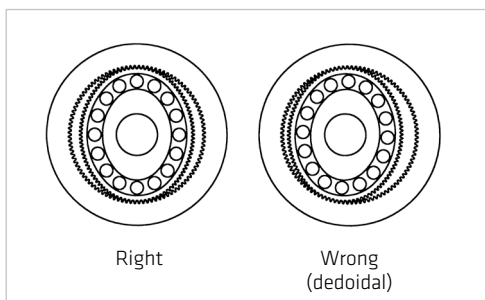

5.7.7 Assembly of the Output Flange

In the case of these Units the load is connected to the output bearing by means of a flange. Depending on the manner of fastening, either the flange which is connected to the outer ring, or the flange which is connected to the internal ring of the output bearing, can be used as output element. The tolerance values indicated in table 53.2 are the sum of bearing and flange tolerances, valid for standard Units. On request Units with optimized flange tolerances are available.

Table 61.1

Size	14	17	20	25	32	40	45	50	58
Number of Bolts	8	16	16	16	16	16	12	16	12
Bolt Size	M3	M3	M3	M4	M5	M6	M8	M8	M10
Bolt pitch diameter [mm]	44	54	62	77	100	122	140	254	178
Tightening Torque [Nm]	2.0	2.0	2.0	4.5	9.0	15.3	37.0	37.0	74.0
Torque transmitting capacity ¹⁾ [Nm]	90	176	206	431	902	1558	2440	3587	4910

5.7.8 Assembly of the Housing Flange

Table 61.2

Size	14	17	20	25	32	40	45	50	58
Number of Bolts	8	12	12	12	12	12	18	12	16
Bolt Size	M3	M3	M3	M4	M5	M6	M6	M8	M10
Bolt pitch diameter [mm]	64	74	84	102	132	158	180	200	226
Tightening Torque [Nm]	2.0	2.0	2.0	4.5	9.0	15.3	15.3	37.0	37.0
Torque transmitting capacity ¹⁾ [Nm]	108	186	206	431	892	1509	2578	3489	5263

* Friction coefficient $\mu = 0.15$; 12.9 quality screws

Housing and output flange is to be assembled as per tables 61.1 and 61.2

5.7.9 Installation of the Input Shaft HFUS-2UH und HFUS-2SH

Table 61.3

Size	14	17	20	25	32	40	45	50	58
Number of Bolts	3	3	6	6	6	6	6	6	8
Bolt Size	M3	M3	M3	M3	M3	M4	M4	M4	M4
Tightening Torque [Nm]	2.1	2.1	2.1	2.1	2.1	4.0	4.0	4.0	4.0

6. Glossary

6.1 Technical Data

AC Voltage constant k_{EM} [$V_{rms} / 1000 \text{ rpm}$]

Effective value of the induced motor voltage measured at the motor terminals at a speed of 1000 rpm and an operating temperature of 20° C.

Ambient operating temperature [°C]

The intended operating temperature for the operation of the drive.

Average input speed (grease lubrication) $n_{av(max)}$ [rpm]

Maximum permissible average gear input speed for grease lubrication.

Average input speed (oil lubrication) $n_{av(max)}$ [rpm]

Maximum permissible average gear input speed for oil lubrication.

Average torque T_A [Nm]

When a variable load is applied to the gear, an average torque should be calculated for the complete operating cycle. This value should not exceed the specified T_A limit.

Backlash (Harmonic Planetary gears) [arcmin]

When subjected to the rated torque, Harmonic Planetary gears display characteristics shown in the hysteresis curve. When a torque is applied to the output shaft of the gear with the input shaft locked, the torque-torsion relationship can be measured at the output. Starting from point O the graph follows successive points A-B-A-B-A where the value B-B' is defined as the backlash or hysteresis.

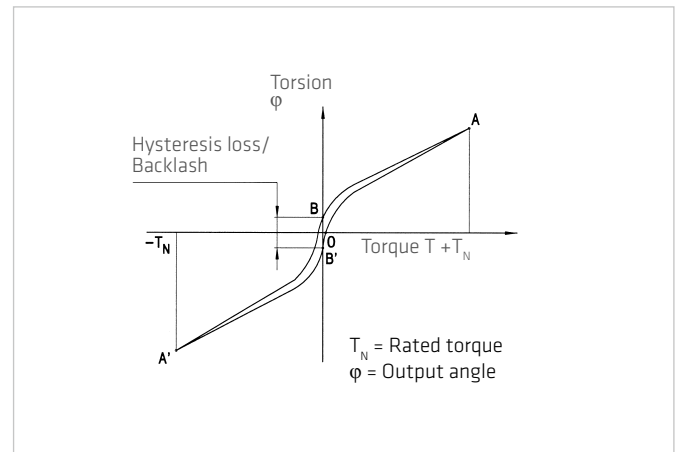

Brake closing time t_c [ms]

Delay time to close the brake.

Brake current to hold I_{HBr} [A_{DC}]

Current for applying the brake.

Brake current to open I_{OBr} [A_{DC}]

Current required to open the brake.

Brake holding torque T_H [Nm]

Torque the actuator can withstand when the brake is applied, with respect to the output.

Brake opening time t_o [ms]

Delay time for opening the brake.

Brake voltage U_{Br} [VDC]

Terminal voltage of the holding brake.

Collision torque T_M [Nm]

In the event of an emergency stop or collision, the Harmonic Drive® Gearing may be subjected to a brief collision torque. The magnitude and frequency of this collision torque should be kept to a minimum and under no circumstances should the collision torque occur during the normal operating cycle.

Continuous stall current I_0 [A_{rms}]

Effective value of the motor phase current to produce the stall torque.

Continuous stall torque T_0 [Nm]

Allowable actuator stall torque.

Demagnetisation current I_E [A_{rms}]

Current at which rotor magnets start to demagnetise.

Dynamic axial load $F_{A\ dyn\ (max)}$ [N]

With bearing rotating this is the maximum allowable axial load, with no additional radial forces or tilting moments applied.

Dynamic load rating C [N]

Maximum dynamic load that can be absorbed by the output bearing before permanent damage may occur.

Dynamic radial load $F_{R\ dyn\ (max)}$ [N]

With bearing rotating this is the maximum allowable radial load, with no additional axial forces or tilting moments applied.

Dynamic tilting moment $M_{dyn\ (max)}$ [Nm]

With the bearing rotating this is the maximum allowable tilting moment, with no additional axial forces or radial forces applied.

Electrical time constant τ_e [s]

The electrical time constant is the time required for the current to reach 63% of its final value.

Hollow shaft diameter d_H [mm]

Free inner diameter of the continuous axial hollow shaft.

Inductance (L-L) L_{L-L} [mH]

Terminal inductance calculated without taking into account the magnetic saturation of the active motor parts.

Lost Motion (Harmonic Drive® Gearing) [arcmin]

Harmonic Drive® Gearing exhibits zero backlash in the teeth. Lost motion is the term used to characterise the torsional stiffness in the low torque region.

The illustration shows the angle of rotation ϕ measured against the applied output torque as a hysteresis curve, with the Wave Generator locked. The lost motion measurement of the gear is taken with an output torque of about $\pm 4\%$ of the rated torque.

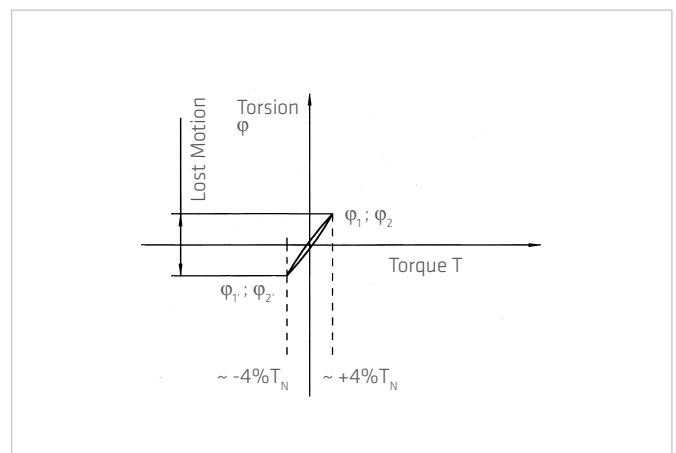

Maximum DC bus voltage $U_{DC(max)}$ [VDC]

The maximum DC bus power supply for the correct operation of the actuator. This value may only be exceeded for a short period during the braking or deceleration phase.

Maximum hollow shaft diameter $d_{H(max)}$ [mm]

For gears with a hollow shaft, this value is the maximum diameter of the axial hollow shaft.

Maximum input speed (grease lubrication) $n_{in(max)}$ [rpm]

Maximum allowed input speed for gearing with grease lubrication.

Maximum input speed (oil lubrication) $n_{in(max)}$ [rpm]

Maximum allowed input speed for gearing with oil lubrication.

Maximum motor speed n_{max} [rpm]

The maximum allowable motor speed.

Maximum output speed n_{max} [rpm]

The maximum output speed. Due to heating issues, this may only be momentarily applied during the operating cycle. The maximum output speed can occur any number of times as long as the rated speed is greater than the permissible continuous operation calculated in the duty cycle.

Maximum output torque T_{max} [Nm]

Specifies the maximum allowable acceleration and deceleration torques. For highly dynamic processes, this is the maximum torque available for a short period. The maximum torque can be parameterized by the control unit where the maximum current can be limited. The maximum torque can be applied as often as desired, as long as the average torque is within the permissible continuous operation calculated in the duty cycle.

Maximum power P_{max} [W]

Maximum power output.

Mechanical time constant τ_m [s]

The mechanical time constant is the time required to reach 63% of its maximum rated speed in a no-load condition.

Momentary peak torque T_M [Nm]

In the event of an emergency stop or collision, the Harmonic Drive® Gearing may be subjected to a brief collision torque. The magnitude and frequency of this collision torque should be kept to a minimum and under no circumstances should the momentary peak torque occur during the normal operating cycle.

Moment of inertia J [kgm²]

Mass moment of inertia at motor side.

Moment of inertia J_{in} [kgm²]

Mass moment of inertia of the gearing with respect to the input.

Moment of inertia J_{out} [kgm²]

Mass moment of inertia with respect to the output.

Motor terminal voltage (Fundamental wave only) $U_M [V_{rms}]$

Required fundamental wave voltage to achieve the specified performance. Additional power losses can lead to restriction of the maximum achievable speed.

Number of pole pairs p

Number of magnetic pole pairs on the rotor of the motor.

Offset $R [mm]$

Distance between output bearing and contact point of load.

Pitch circle diameter $d_p [mm]$

Pitch circle diameter of the output bearing.

Protection IP

The degree of protection according to EN 60034-5 provides suitability for various environmental conditions.

Rated current $I_N [A]$

Rms value of the sinusoidal current when driven at rated torque and rated speed.

Rated motor speed $n_N [rpm]$

The motor speed which can be continuously maintained when driven at rated torque T_N , when mounted on a suitably dimensioned heat sink.

Rated power $P_N [W]$

Output power at rated speed and rated torque.

Rated speed $n_N [rpm]$

The output speed which can be continuously maintained when driven at rated torque T_N , when mounted on a suitably dimensioned heat sink.

Rated torque $T_N [Nm]$, Servo

The output torque which can be continuously transmitted when driven at rated input speed, when mounted on a suitably dimensioned heat sink.

Rated torque $T_N [Nm]$, Mechanic

The rated torque is a reference torque for the calculation of the gear life. When loaded with the rated torque and running at rated speed the gear will reach the average life L_{50} . The rated torque T_N is not used for the dimensioning of the gear.

Rated voltage $U_N [V_{rms}]$

Supply voltage for operation with rated torque and rated speed.

Ratio $i []$

The ratio is the reduction of input speed to the output speed.

Note for Harmonic Drive® transmission: The standard version of the wave is generating the drive element, the output element of the flexspline and the circular Spline is fixed to the housing. Since the direction of rotation of the drive (Wave Generator) to output reverses (Flexspline), a negative ratio for results Calculations in which the direction of rotation must be considered.

Repeatability [arcmin]

The repeatability of the gear describes the position difference measured during repeated movement to the same desired position from the same direction. The repeatability is defined as half the value of the maximum difference measured, preceded by a \pm sign.

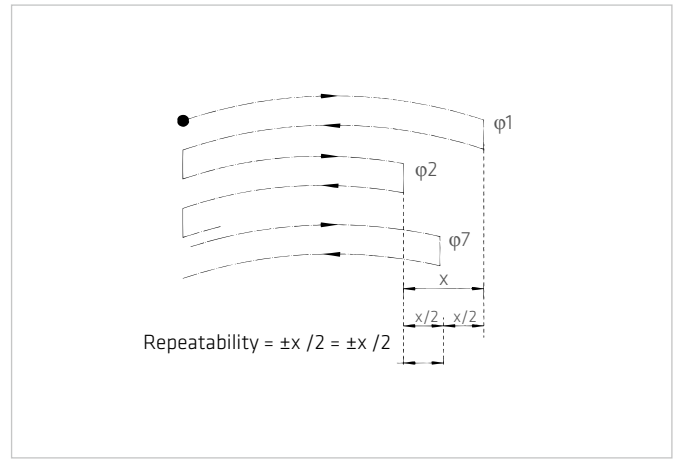

Repeatable peak torque T_R [Nm]

Specifies the maximum allowable acceleration and braking torques. During the normal operating cycle the repeatable peak torque T_R should not be exceeded.

Resistance (L-L, 20° C) R_{L-L} [Ω]

Winding resistance measured between two conductors at a winding temperature of 20° C.

Size

1) Actuators / Gears with Harmonic Drive® gears or Harmonic Planetary gears

The frame size is derived from the pitch circle diameter of the gear teeth in inches multiplied by 10.

2) CHM Servo motor series

The size of the CHM servo motors is derived from the stall torque in Ncm.

3) Direct drives from the TorkDrive® series

The size of the TorkDrive® series is the outer diameter of theiron core of the stator.

Static load rating C_0 [N]

Maximum static load that can be absorbed by the output bearing before permanent damage may occur.

Static tilting moment M_0 [Nm]

With the bearing stationary this is the maximum allowable radial load, with no additional axial forces or tilting moments applied.

Tilting moment stiffness K_b [Nm/arcmin]

The tilting angle of the output bearing at an applied moment load.

Torque constant (motor) k_{TM} [Nm/A_{rms}]

Quotient of stall torque and stall current.

Torque constant (output) k_{Tout} [Nm/A_{rms}]

Quotient of stall torque and stall current, taking into account the transmission losses.

Torsional stiffness (Harmonic Drive® Gears) K_3 [Nm/rad]

The amount of elastic rotation at the output for a given torque and the Wave Generator blocked. The torsional stiffness K_3 describes the stiffness above a defined reference torque where the stiffness is almost linear. Values below this torque can be requested or found on our web site.

The value given for the torsional stiffness K_3 is an average that has been determined during numerous tests. The limit torques T_1 and T_2 and calculation example for the total torsional angle Gesamtverdrehwinkels can be found in the secondary technical documentation.

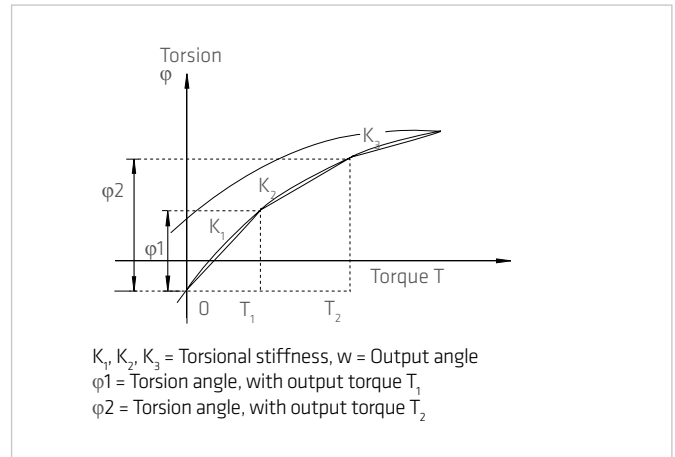

Torsional stiffness (Harmonic Planetary gears) K [Nm/rad]

The amount of elastic rotation at the output for a given torque and blocked input shaft. The torsional rigidity of the Harmonic Planetary gear describes the rotation of the gear above a reference torque of 15% of the rated torque. In this area the torsional stiffness is almost linear.

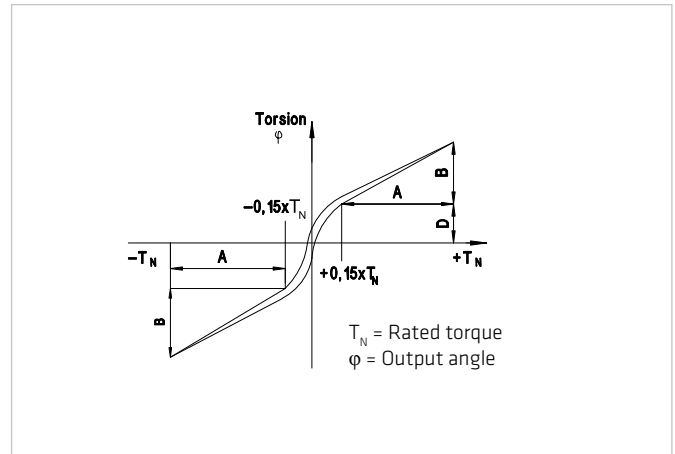

Transmission accuracy [arcmin]

The transmission accuracy of the gear represents a linearity error between input and output angle. The transmission accuracy is measured for one complete output revolution using a high resolution measurement system. The measurements are carried out without direction reversal. The transmission accuracy is defined as the sum of the maximum positive and negative differences between theoretical and actual output rotation angle.

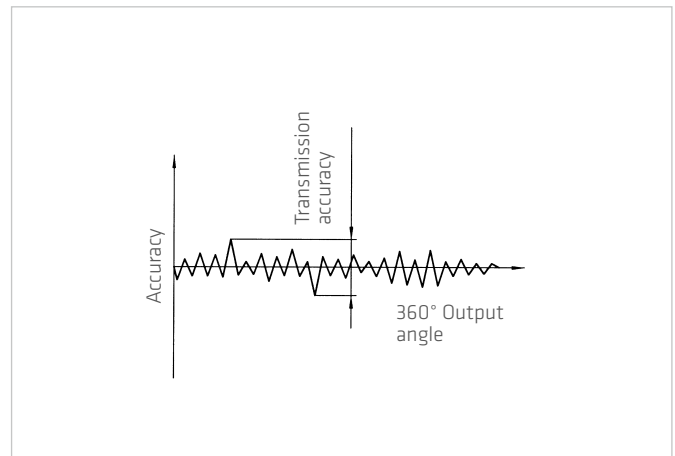

Weight m [kg]

The weight specified in the catalog is the net weight without packing and only applies to standard versions.

6.2 Labelling, Guidelines and Regulations

CE-Marking

With the CE marking, the manufacturer or EU importer declares in accordance with EU regulation, that by affixing the CE mark the product meets the applicable requirements in the harmonization legislation established the Community.



REACH Regulation

REACH is a European Community Regulation on chemicals. REACH stands for Registration, Evaluation, Authorization and Restriction of Chemicals.



RoHS EU Directive

The RoHS EU Directive on the restriction of the use of certain hazardous substances in electrical and electronic equipment.

