

The Dowty 'Bonded Seal'

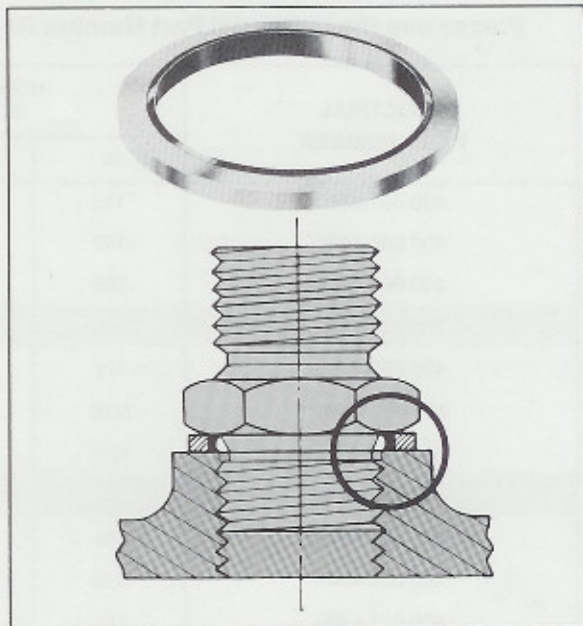

High Pressure Joint Gasket Seal

The Dowty Bonded Seal is a synthetic rubber sealing member that is bonded with heat and pressure to a zinc plated steel washer. The flexing action of the lips under pressure provides a positive and leakproof seal against a wide range of fluids, at, depending upon size, pressures up to 20,000 p.s.i. (1380 bar). The Dowty Bonded Seal, in addition to eliminating leakage, reduces tooling, installation and maintenance costs. The face to face sealing they permit eliminates groove cutting or special machining and reduced bolting torque. Dowty Bonded Seals are supplied in quantity to large scale users in the aircraft, motor and electronics industries, and for specialized products ranging from navigational instruments to rock drilling equipment.

Materials & Temperature Range

The Dowty Bonded Seal is suitable for use with mineral oils, water, gases and many other fluids. The temperature range varies according to the particular application. For general conditions, the 400 Series operates from -40°F to $+212^{\circ}\text{F}$ (-40°C to $+100^{\circ}\text{C}$).

Low Octane Fuels

The Dowty Bonded Seal is available in the full range of sizes for low octane fuels, diesel oil, etc., suitable for temperature ranges of -20°F to $+240^{\circ}\text{F}$ (-29°C to $+120^{\circ}\text{C}$).

Tapped Holes

When bonded seals are used to seal tapped holes the thread relief should never be greater than 0.01 in. (0.25 mm) above the nominal outside diameter of the screw thread.

- Extremely simple pressure gasket.
- Efficient and reliable means of face sealing at high and low pressures.
- Positive and leakproof sealing action.
- Reduction in bolting torque.
- No flow or flattening of metal washer under tightening loads.
- Elimination of groove cutting or special machining.
- Reusable when remaking joints.
- Continuous operation at -40°F to $+212^{\circ}\text{F}$ (-40°C to $+100^{\circ}\text{C}$).
- Reduces machining, installation and maintenance costs.

DOWTY BONDED SEALS

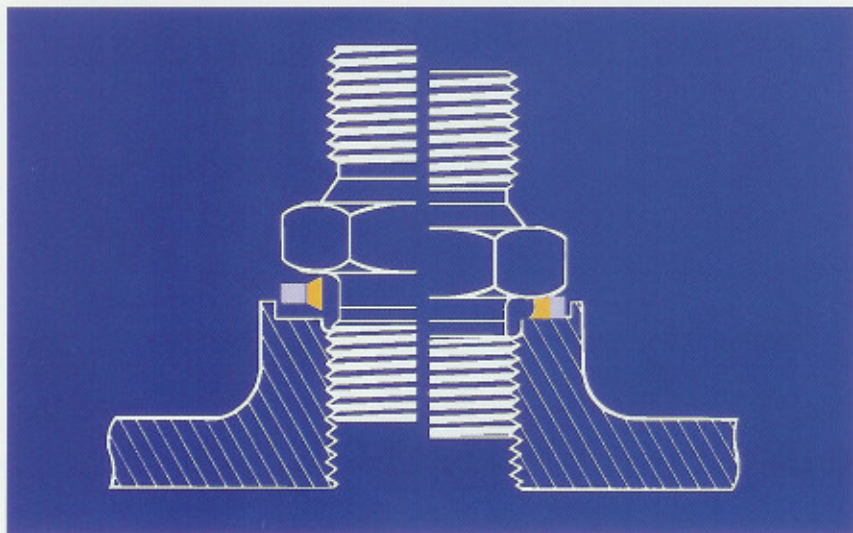

The Dowty bonded seal was originally designed to replace copper type washers in higher pressure systems. Simple in construction the gasket comprises a metal annulus, square or rectangular in section, to which an elastomeric ring of trapezoidal section is bonded. The metal ring resists the bursting forces and limits the deformation of the elastomeric element.

THE KEY BENEFITS

- RELIABLE HIGH AND LOW PRESSURE SEALING
- WIDE TEMPERATURE CAPABILITY
- METAL RING PREVENTS OVER-COMPRESSION AND EXTRUSION
- LARGE RANGE OF ELASTOMERS AND METALS
- FULL TRACEABILITY THROUGH PACKAGING, FOR ALL ITEMS
- ALL EUROPEAN THREAD SIZES AVAILABLE

DOWTY SELF-CENTRING BONDED SEALS

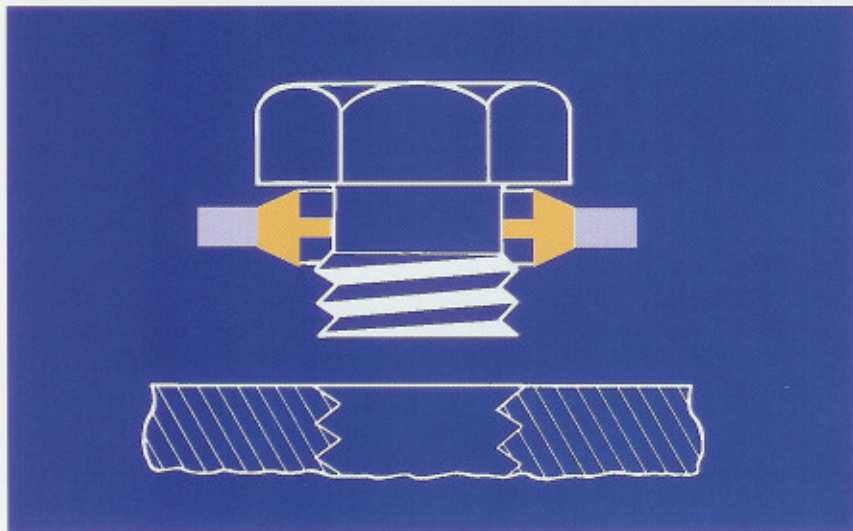

Developed to eliminate the occurrence of leakage due to seal offset, the self-centring type of bonded seal has the additional benefit of pre-assembling on to threads with the consequent production line savings. The thin seal membrane offers little resistance during assembly.

THE KEY BENEFITS

- ALL KEY BENEFITS FROM THE ORIGINAL BONDED SEAL
- CONCENTRICALLY LOCATED
- POSITIVELY RETAINED
- EASE OF ASSEMBLY
- ABILITY TO PRE-ASSEMBLE
- OPTIMISED COMPONENT STOCKING
- SIMPLIFIED LOCATION MACHINING

ORDER REFERENCES

Dowty Part No.

4	0	0	-	8	2	5	-	4	4	9	0	-	4	1
Product Reference				Size and Range Reference				Rubber Material Reference					Metal Outer Ring	

PRODUCT REFERENCE

Bonded Seals - Aerospace 300

Bonded Seals - Industrial 400

SIZE AND RANGE REFERENCES

Select from pages 6 to 12 the required type and size of product and insert the appropriate size reference.

e.g. 825= $\frac{1}{2}$ " BSP self-centring bonded seal

RUBBER MATERIAL REFERENCES

From pages 3 and 4 select the compound most suitable to the application requirements.

e.g. 4490=non-released 90 IRHD medium nitrile

METAL OUTER RING

See page 5 for available metals. As with the elastomeric material, preferred metal types should be used if possible.

Dowty produces a large number of special bonded seals by shape, size and material. Each is given a unique part number by Dowty Bonded Seals technical department.

INDUSTRIAL NON-RELEASED ELASTOMERIC MATERIALS

The most commonly used non-released materials are the 4490 nitrile and the 9775 fluorocarbon. Combined with the 41 zinc plated mild steel metal outer ring these are the most widely stocked ranges.

Dowty Compound Reference	APPLICATIONS										Polymer Base	Material Specification	Temperature Range °C Hardness IRHD
	MINERAL BASED HYDRAULIC FLUIDS	NATIONAL WATER COUNCIL APPROVED	FOOD & DRUG AUTHORITY APPROVED	PETROL	ENGINE LUBRICATING OILS	HIGH TEMPERATURE APPLICATIONS	OZONE RESISTANCE	HIGH TEMP STEAM ACIDS & ALKALIS	HOT AIR	POLYGLYCOL BASED FLUIDS			
5575	•			•	•						HIGH NITRILE	ASTM D2000 M2 BG710, B14, EF11, EF21 EO14, EO34, Z1, Z2, Z3	-30 to +110 70-80
5590	•			•	•							ASTM D2000 M6BG910 A14, B14, EO14, EO34 Z1	-25 to +110 85-95
0117	•		•	•	•							DTD 900/4319	-30 to +110 65-75
4470	•				•						MEDIUM NITRILE	1). ASTM D2000, M2BG714, B14 EA14,EF11,EF21,EO14,EO34,F17 Z and 2).ASTM D2000 M2CH714 A25, B14, EO15, EO35, F17	-40 to +110 65-75
4490	•		•		•							ASTM D2000 M7 BG910, B14, EA14 EF11, EF21,EO14 EO34, F16, Z1, Z2	-30 to +110 85-95
2455		•	•									1).Water Research Centre-Water Fittings Byelaw 2).B56920-1987 3).ASTM D2000,2MBG714,B14,EA14, FF11, EF21, EO14, EO34, F17, Z1, Z2.	-40 to +110 65-75
1631	•			•	•	•	•		•		FLUORO-CARBON		-10 to +225 80-90
9707	•			•	•	•	•		•			ASTM D2000 M6HK710 A1-10 B38, EF31, Z1, Z2	-15 to +225 65-75
9775	•			•	•	•	•		•	•		ASTM D2000 M6HK 810 A1-10, B38, EF31, EO88, Z1, Z2, Z3.	-15 to +225 70-80
8825	•			•	•	•	•		•	•	FLUORO-SILICONE		-60 to +200 55-65
8870						•	•	•	•		SILICONE	ASTM D2000, M5GE 706 A19, B37, EA14, EO16, EO36, F19, G11	-60 to +200 65-75
2064		•				•	•	•	•	•	ETHYLENE PROPYLENE	ASTM D2000, M3DA710 A26, B36, C32, EA14, F19, Z1, Z2.	-50 to +135 70-80
2484						•	•	•	•		AFLAS		-5 to +200 75-85
2471	•			•	•	•	•		•	•	HNBR	ASTM D2000, M5CH814 A25, B34, C12, EO15, EO35, F14, Z1, Z2, Z3, Z4.	-30 to +130 75-85

PREFERRED COMPOUNDS

AEROSPACE AND DEFENCE RELEASED MATERIALS

The more popular ranges of 1911 (medium nitrile) and 0967 (fluorocarbon) combined with cadmium plated mild steel metal outer (02) are widely available as stock items.

APPLICATIONS

Dowty Compound Reference	MINERAL BASED HYDRAULIC FLUIDS	AVIATION FUELS	DIESTER TYPE LUBRICATING OILS	ENGINE LUBRICATING OILS	PHOSPHATE ESTHER FLUIDS	HIGH AIR PRESSURE	OZONE RESISTANCE	HIGH TEMPERATURE FLUIDS	HOT AIR	POLYGLYCOL BASED FLUIDS	Polymer Base	Material Specification	Temperature Range °C Hardness IRHD
0075	•	•	•	•		•					HIGH NITRILE	DTD 5509 GRADE A	-25 to +110 84-96
0073	•	•	•	•		•						DTD 5509 GRADE C	-25 to +110 62-72
5615	•	•		•								DTD 560 GRADE A QUALITY P	-20 to +80 84-96
2264	•	•		•								NFL171 21A7	-20 to +120 65-75
1911	•			•							MEDIUM NITRILE	DTD 458A GRADE B, GRADE 1	-40 to +80 85-95
0008	•			•								DTD 458A GRADE B, GRADE 1	-40 to +80 85-95
2261	•			•								NFL17 120A8	-30 to +120 75-85
0078	•										LOW NITRILE	AFS 1043D DTD900/6019A	-50 to +80 67-73
2263	•											NFL17 120B8	-50 to +100 75-85
0967	•	•	•	•		•	•	•	•		FLUORO-CARBON	AFS 489B DTD900/4999	-10 to +200 71-79
8903	•	•		•			•	•			FLUORO-SILICONE	NFL171 -61D8	-55 to +150 75-85
8839							•		•		SILICONE	AFS1365B	-60 to +200 66-75
8810							•		•			DTD5582B GRADE 70 Oring DTD 5605A	-65 to +150 65-75
2933					•	•	•			•	ETHYLENE PROPYLENE	AFS 2325	-50 to +120 76-84
2275					•	•	•			•		NAS 1613	-50 to +120 75-85
0088										•	STYRENE BUTADIENE	DTD900/6018	-50 to +80 81-89
0107				•			•				POLYCHLORO-PRENE	BS2752 C80	-30 to +80 76-85

PREFERRED COMPOUNDS

BONDED SEALS - METAL OUTER RINGS

MOST COMMONLY USED RELEASED METALS

MOST COMMONLY USED INDUSTRIAL METALS

Dowty Metal Reference	Metal Type	Material Specification	Tensile Strength MN/m ² (minimum)	Special Plating Conditions
02	MILD STEEL CADMIUM PLATED	BS1449 PART 1: 1983 CS4 BRH 5	540	CADMIUM PLATED TO DTD904C OR DEF STAN 03-19, COLOUR PASSIVATED TO DEF 03-33
12	MILD STEEL CADMIUM PLATED	BS1449 PART 1: 1983 CS4 BRH 5	540	CADMIUM PLATED TO DTD904C OR DEF STAN 03-19 WITH IDENTIFICATION MARKS TO GD1967 COLOUR PASSIVATED TO DEF 03-33
13	MILD STEEL CADMIUM PLATED	BS1449 PART 1: 1983 CS4 BRH 5	540	CADMIUM PLATED TO DTD904C OR DEF STAN 03-19 WITH IDENTIFICATION MARKS TO GD1483
41	MILD STEEL ZINC PLATED	BS1449 PART 1: 1983 CS4 BRH 5	540	ZINC PLATED TO DEF STAN 03-20/1 COLOUR PASSIVATED TO DEF 03-33
08	STAINLESS STEEL TYPE 416	BS1449 PART 2 410 S21	540	
31	STAINLESS STEEL AEROSPACE RELEASED MATERIAL	BS 5130	540	LOW MAGNETISM (AUSTENITIC)
74	STAINLESS STEEL TYPE 316	BS1449 PART 2 316 S33	540	
26	HIGH STRENGTH STEEL	BS970 PART 1: 1983 817 M4OU	925	
73	HIGH STRENGTH STEEL CADMIUM PLATED	BS970 PART 1: 1983 817 M4OU	925	CADMIUM PLATED TO DTD904C OR DEF STAN 03-19 COLOUR PASSIVATED TO DEF 03-33
19	LIGHT ALLOY	L102 1971 (1985)	370	
05	LIGHT ALLOY ANODISED	L168:1978 BAR L156:1978 (SHEET & STRIP)	370	ANODISED TO DEF STAN 03-24
16	LIGHT ALLOY ANODISED RED SEE NOTE BELOW	L102 1971 (1985)	370	ANODISED TO DEF STAN 03-24 (RED)
18	LIGHT ALLOY ANODISED GREEN SEE NOTE BELOW	L102 1971 (1985)	370	ANODISED TO DEF STAN 03-24 (GREEN)
10	BASS	STEEL STRIP BS2870:1980 CZ106 BAR BS2876:1986 CZ121	380	
09	BASS	STEEL STRIP BS2870:1980 CZ106 BAR BS2876:1986 CZ121	380	CADMIUM PLATED TO DEF STAN 03-33
28	ALUMINIUM BRONZE	BS2874: 1986 CZ104	700	

Note: For identification purpose light alloy 16 (red) is used with 5615 elastomer; light alloy 18 (green) is used with 0073 elastomer.

ORIGINAL RANGE - BRITISH IMPERIAL

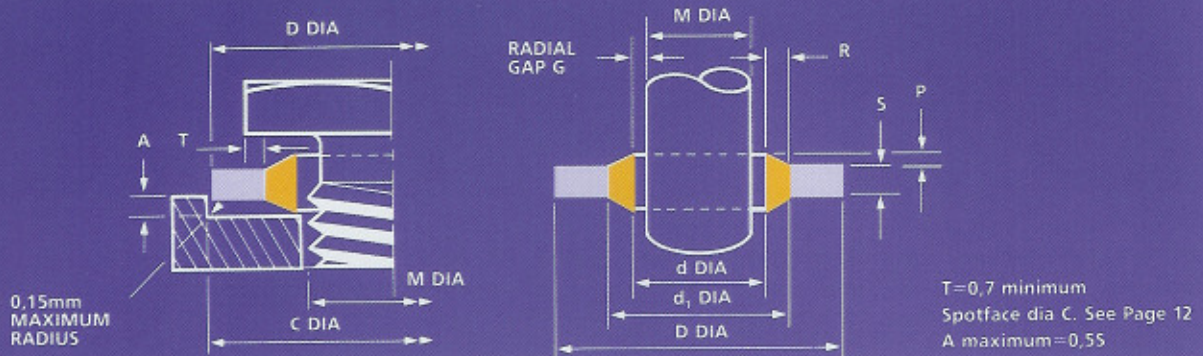

BONDED SEAL

THREAD DIA M		SIZE REFERENCE		D +0,13 -0,00	d ±0,13	d ₁ ±0,13	S	R ±0,13	P	RADIAL GAP G+0,07		MINIMUM BURST PRESSURE BAR
INCH	BSP	***	†							INCH	BSP	
6BA		001	1	6,35	3,05	4,09/4,16		0,54				2150
4BA		002	2	7,26	4,12	5,26		0,57				1570
2BA		003	3	8,38	5,21	6,35		0,57				1360
1/4		004	4	13,21	6,86	8	1,22	+0,15	0,25/0,38	0,26		2430
1/4		005	5	13,34	6,99	9,53		-0,00		0,32		1680
3/16		006	6	13,34	8,31	9,53				0,19		1680
3/16		007	7	14,22	8,64	10,04				0,35		1750
3/8	1/8	020	A	15,88	10,37	11,84				0,73	0,32	1480
40		008	8	18,36	11,26	12,45				0,60		1950
7/16		009	9	19,05	11,69	13,08				0,70		1890
1/2	1/4	021	B	20,57	13,74	15,21	2,00	±0,1		0,73	0,29	1540
9/16		010	10	22,23	14,86	16,39				0,76		1560
60		022	BB	22,23	15,83	17,30				0,73		1290
3/8		011	11	25,40	16,51	18,75				1,12		1560
	3/8	023	C	23,80	17,28	18,75				0,73	0,31	1230
11/16		012	12	25,40	18,16	19,69				0,76		1310
3/4		024	CC	26,92	19,69	21,21				0,76		1230
13/16	1/2	025	D	28,58	21,54	23,01				0,73	0,29	1120
7/8	3/8	026	E	31,75	23,49	24,97				0,74	0,29	1240
15/16		013	13	33,27	24,26	26,04	2,34			0,89		1275
1	3/4	027	F	34,93	27,05	28,53				0,74	0,30	1050
1 1/16		028	FF	38,61	27,82	30,61				1,40		1210
1 1/8		014	14	36,58	29,33	30,86			0,25/0,51	0,76	0,38	880
1 1/16	3/8	029	G	38,10	30,81	32,39				0,74	0,30	860
1 1/4		015	15	41,40	32,64	35,69	3,25			1,52		775
1 1/16	1	030	H	42,80	33,89	36,88	3,25			1,50	0,40	780
1 1/16	1	031	HH	42,80	33,89	36,88	2,34	+0,26		1,50	0,40	780
1 3/8		016	16	44,45	35,94	38,99		-0,00		1,52		680
1 1/2		017	17	47,75	38,96	42,04				1,54		660
1 5/8	1 1/4	032	J	52,38	42,93	45,93				1,50	0,51	690
1 3/4		018	18	57,15	45,34	48,39				1,52		870
1 7/8	1 1/2	033	K	58,60	48,44	51,39				1,47	0,32	690
2		019	19	63,50	51,69	54,74	3,25			1,52		780
2 1/8	1 3/4	034	L	69,85	54,89	58,30				1,70	0,57	950
2 1/4		035	LL	70,36	58,04	61,09				1,52		740
	2	036	M	73,03	60,58	63,63				1,52	0,48	720
2 1/2		037	MM	77,72	64,39	67,44				1,52		750
	2 1/4	038	N	79,50	66,68	69,98				1,65	0,59	670
	2 1/2	039	P	90,17	76,08	79,38				1,65	0,45	680

Note: *** size reference fourth, fifth, sixth digits. Previous mark numbers for PP45 (industrial) and AGS1186 are shown by symbol †
Burst pressures were calculated using 540MN/m² (35 ton f/in²) UTS steel

SELF-CENTRING RANGE

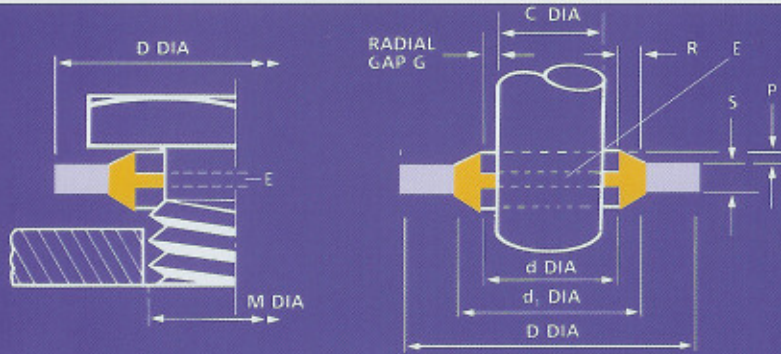

THREAD SIZE M	SIZE REFERENCE	d ϕ ± 0.13	C ϕ CENTRALISING LIP	E	P	R ± 0.1	d1 ϕ ± 0.10	D ϕ $+0.13$	S ± 0.10
M8	866	8.70	6.40	0.38/0.63	0.25/0.51	0.20	10.40	14.00	1.00
1/8 BSP	820	10.37	8.26				11.84	15.88	2.00
M10	708	10.70	8.05				12.40	16.00	1.50
M12	867	12.70	9.73				14.10	19.00	1.50
1/4 BSP	821	13.74	11.18				15.21	20.57	2.00
M14	868	14.70	11.38				16.40	22.00	1.50
3/8	869	16.51	12.90				18.75	25.40	2.00
M16	870	16.70	13.41				18.40	24.00	1.50
3/8 BSP	823	17.28	14.76				18.75	23.80	2.00
11/16	871	18.16	14.50				19.69	25.40	2.40
M18	872	18.70	14.76				20.40	26.00	1.50
M20	873	20.70	16.76				22.50	28.00	1.50
1/2 BSP	825	21.54	18.24				23.01	28.58	2.47
M22	874	22.70	18.74				24.40	30.00	2.00
5/8 BSP	826	23.49	20.27				24.97	31.75	2.47
M24	875	24.70	20.11				26.40	32.00	2.00
3/4 BSP	827	27.05	23.83	28.53	34.93	2.47			
7/8 BSP	829	30.81	27.51	32.29	38.10	2.47			
1 BSP	830	33.89	29.92	36.88	42.80	3.40			
1 1/4 BSP	832	42.93	38.45	45.93	52.38	3.40			
1 1/2 BSP	833	48.44	44.45	51.39	58.60	3.40			
1 3/4 BSP	834	54.89	50.42	58.30	69.85	3.40			
2 BSP	836	60.58	56.26	63.63	73.03	3.40			
2 1/4 BSP	838	66.68	62.36	69.98	79.50	3.40			
2 1/2 BSP	839	76.08	71.50	79.38	90.17	3.40			

GERMAN METRIC RANGE

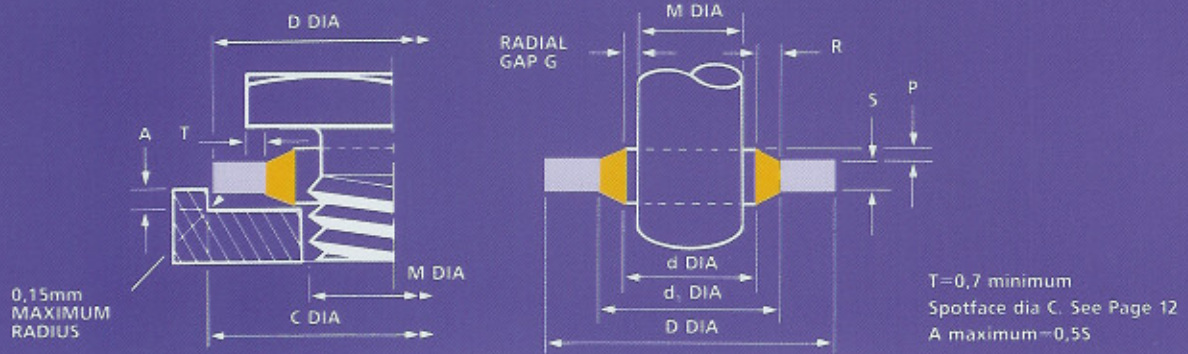

THREAD SIZE DIA M	SIZE REFERENCE	D +0,13 -0,00	d ±0,10	d ₁ ±0,10	S	R ±0,1	P +0,25 -0,00	RADIAL GAP G ±0,05	MINIMUM BURST PRESSURE BAR
3,5	201	7,2	4,1	5,2	1,0±0,1	0,55	0,30	0,30	1600
4	202	7,0	4,5	5,4		0,45		0,25	1270
5	203	9,0	5,7	6,8		0,65		0,35	1400
5	204	10,0	5,7	7,4		0,85		0,35	1510
5,5	205	9,2	6,2	7,2		0,5		0,35	1220
6	206	10,0	6,7	8,0		0,65		0,35	1120
6	207	11,0	6,7	8,2		0,75		0,35	1480
6	208	11,0	6,7	8,2	2,5±0,1	0,75		0,35	1480
6,5	209	12,0	7,1	8,8	1,0±0,1	0,85		0,30	1560
6,7	210	10,2	7,3	8,6		0,65		0,30	850
8	211	13,4	8,5	9,4		0,45		0,25	1780
8	212	13,0	8,7	10,0		0,65		0,35	1330
8	213	14,0	8,7	10,4		0,85		0,35	1510
8	214	16,0	8,7	10,4		0,85		0,35	2150
8,5	215	13,3	9,3	10,5		0,60	0,40	1200	
10	216	16,0	10,35	12,0	2,0±0,1	0,82	0,17	1470	
10	217	16,0	10,7	12,4	1,5±0,1	0,85	0,35	1300	
10	218	18,0	10,7	12,4		0,85	0,35	1880	
11	219	16,3	11,4	12,7		0,65	0,40	1280	
11	220	18,5	11,8	13,7		0,95	0,40	1540	
11	221	19,1	11,8	13,5	0,85	0,40	1760		

Burst pressures were calculated using 540MN/m² (35 ton f/in²) UTS steel

THREAD SIZE DIA M	SIZE REFERENCE	D +0,13 -0,00	d ±0,10	d ₁ ±0,10	S	R ±0,1	P +0,25 -0,00	RADIAL GAP G ±0,05	MINIMUM BURST PRESSURE BAR
12	222	18,0	12,7	14,4	1,5±0,1	0,85	0,40	0,35	1150
12	223	20,0	12,7	14,4		0,85		0,35	1680
13	224	20,0	13,7	15,4		0,85		0,35	1340
13	225	22,0	13,7	15,4		0,85		0,35	1810
13,5	226	18,7	14,0	15,7		0,85		0,25	900
14	227	22,0	14,7	16,4		0,85		0,35	1510
15	228	22,7	16,0	17,78		0,89		0,50	1260
16	229	24,0	16,7	18,4		0,85		0,35	1370
17	230	24,0	17,4	19,2		0,90		0,20	1150
17,5	231	24,7	18,0	20,1		1,05		0,25	1070
18	232	26,0	18,7	20,4		0,85		0,35	1260
20	233	28,0	20,7	22,5		0,90		0,35	1140
21	234	28,7	21,5	23,3		2,5±0,15		0,90	0,25
22	235	28,0	22,5	24,2	1,5±0,1		0,25	760	
22	236	30,0	22,7	24,4	2,0±0,1	0,85	0,35	1080	
22	237	30,0	22,7	24,4	3,0±0,1	0,85	0,35	1080	
24	238	32,0	24,7	26,4	2,0±0,1	0,85	0,35	1000	
27	240	36,0	27,2	29,0		0,90	0,10	1130	
30	242	39,0	31,0	33,0		1,0	0,50	870	
33	243	42,0	33,7	35,8		1,05	0,35	840	
33	244	43,0	34,3	36,4		1,05	0,65	870	
36	245	46,0	36,7	38,8		1,05	0,35	890	
39	246	51,0	40,0	41,9		2,5±0,1	0,95	0,50	1030
42	247	53,0	42,7	44,4		0,85	0,35	930	
48	248	59,0	48,7	50,8		1,05	0,35	790	
51	249	60,0	52,0	54,1		3,0±0,15		0,50	540
52	250	64,5	53,3	56,4			0,65	710	
60	251	73,0	60,7	63,0		1,15	0,35	780	
68	252	79,5	68,6	72,1	3,5±0,15	1,75	0,30	510	
75	253	90,3	76,08	79,1	3,38±0,15	1,51	0,54	700	
88	254	101,48	89,09	92,1	3,25±0,15	1,50	0,54	510	
125	255	143,67	127,0	132,7	5,0±0,15		1,0	420	

PREFERRED SIZE WHERE OPTIONS ARE PRESENT

FRENCH METRIC RANGE

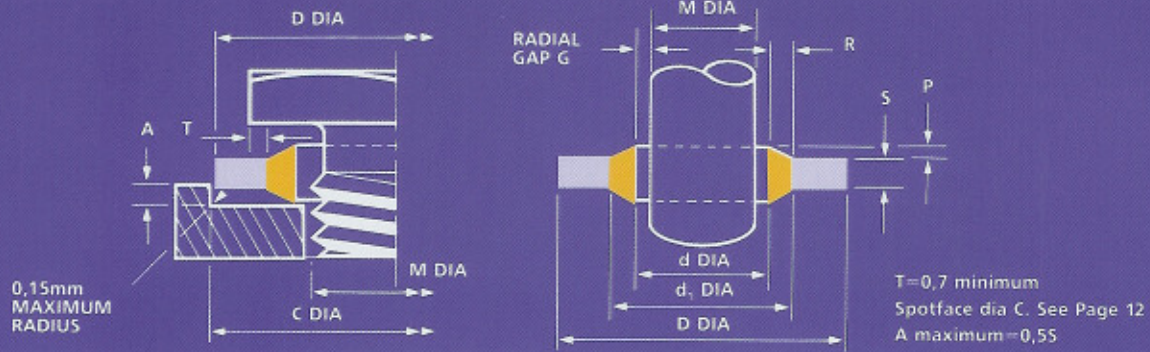

THREAD SIZE DIA M	SIZE REFERENCE	D +0,13 -0,00	d ±0,10	d ₁ ±0,10	S	R ±0,1	P +0,25 -0,00	RADIAL GAP G ±0,05	MINIMUM BURST PRESSURE BAR
3	301	7,5	3,6	5		0,7	0,30	0,3	1980
4	302	9	4,6	6		0,7		0,3	2000
5	303	10	5,6	7	1,0±0,1	0,7		0,3	1780
6	304	11	6,6	8		0,7		0,3	1680
6	305	13,27	6,85	8	1,3±0,1	0,57		0,42	1970
6	306	11,4	7	8,4		0,7		0,5	1540
8	307	13	8,6	10	1,0±0,1	0,7		0,3	1330
10	310	17	10,7	12,1		0,7		0,35	1730
11	312	18,1	11,8	13,2		0,65		0,4	1610
12	313	19	12,7	14,1		0,7		0,4	1530
13	315	20,1	13,8	15,2	1,5±0,1	0,7	0,4	1430	
14	316	21	14,7	16,1		0,7	0,35	1370	
16	317	23	16,7	18,1		0,7	0,35	1240	
16,5	319	23,9	17,2	18,7	2,1±0,1	0,75	0,35	1020	
17	318	23,7	17,4	18,8	1,5±0,1	0,7	0,2	1130	
18	320	27	18,7	20,4		0,85	0,35	1450	
20	321	29	20,7	22,4		0,85	0,35	1340	
21	323	30	21,7	23,4		0,85	0,35	1290	
22	324	31	22,7	24,4		0,85	0,35	1240	
23	325	32	23,7	25,4		0,85	0,40	0,35	965
24	326	33	24,7	26,4	2,0±0,1	0,85		0,35	1160
26	327	35,3	27	28,7		0,85		0,5	860
27	328	36	27,7	29,4		0,85		0,35	1060
28	329	36	28,6	30,3		0,85		0,3	720
28,5	330	37,5	29,2	30,9		0,85		0,35	810
30	331	39	30,7	32,4		0,85		0,35	970
33	332	42	33,7	35,4		0,85		0,35	900
36	333	48	37	39,6		1,3		0,5	1010
39	334	51	40	42,6		1,3		0,5	950
42	335	54	43	45,6	2,5±0,15	1,3	0,5	890	
45	336	57	46	48,6		1,3	0,5	860	
48	337	60	49	51,6		1,3	0,5	790	

Burst pressures were calculated using 540MN/m² (35 ton f/in²) UTS steel

BONDED SEALS TO SUIT PIPE CONNECTIONS AND COUPLINGS

AS RECOMMENDED IN ISO1179—1973
(FORMERLY A CETOP RECOMMENDATION)

INSTALLATION DATA

Series C

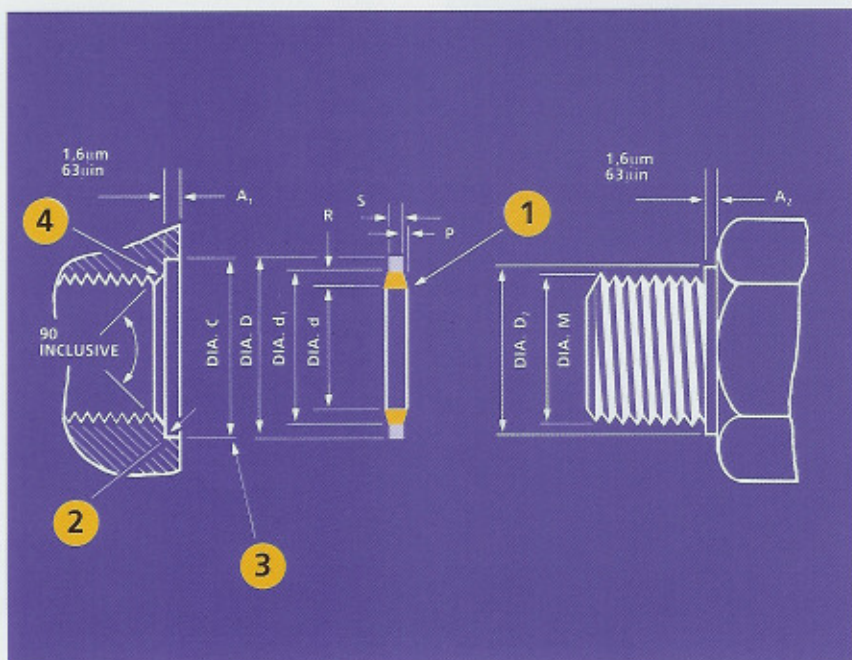

- 1 IRREGULAR, ADHERING FLASH PERMISSIBLE
0.38mm WIDE MAXIMUM
(0.015in)
- 2 0.13mm MAXIMUM RADIUS (0.005in)
THE JOINT SURFACE IS TO BE FLAT AND SQUARE TO THE AXIS OF THE THREAD.
- 3 CONCENTRICITY TOLERANCE 0.25mm (0.010in) DIAMETER
MAXIMUM DATUM THREAD DIAMETER
- 4 THE DIAMETER OF CHAMFER OR COUNTERBORE FOR REMOVAL OF FIRST THREAD MUST BE CONCENTRIC WITH AND NOT EXCEED THE THREAD DIAMETER

THREAD DIA. 'M' BSP	BONDED SEAL							D ₂ +0,5	A A ₁ max A ₂ min	C +0,4	MINIMUM BURST PRESSURE BAR
	SIZE REF ***	D -0,2	d +0,2	d ₁ +0,2	S ±0,15	R ±0,2	P +0,25 -0,00				
1/16	519	12,7	8,3	9,9	1,25	0,8	0,25	12	1	13	1100
1/8	510	14,7	10,4	12		0,8		14	1	15	930
1/4	511	18,7	13,85	15,75		0,95		18	1,5	19	793
3/8	512	22,7	17,35	19,25		0,95		22	2	23	775
1/2	513	26,7	21,65	23,55		0,95		26	2,5	27	586
3/4	514	32,5	27,3	29,2		0,95		32	2,5	33	500
1	515	39,5	34,2	36,1		2		0,95	39	2,5	40
1 1/4	516	49,5	42,8	44,7	0,95		49	2,5	50	500	
1 1/2	517	55,5	48,7	50,6	0,95		55	2,5	56	434	
2	518	68,5	60,5	62,4	0,95		68	3	69	448	

Part number example 400-510-4490-41

Burst pressures were calculated
using 540 MN/m² (35 ton f/in²)
UTS steel

BONDED SEALS - INSTALLATION DATA

ORIGINAL

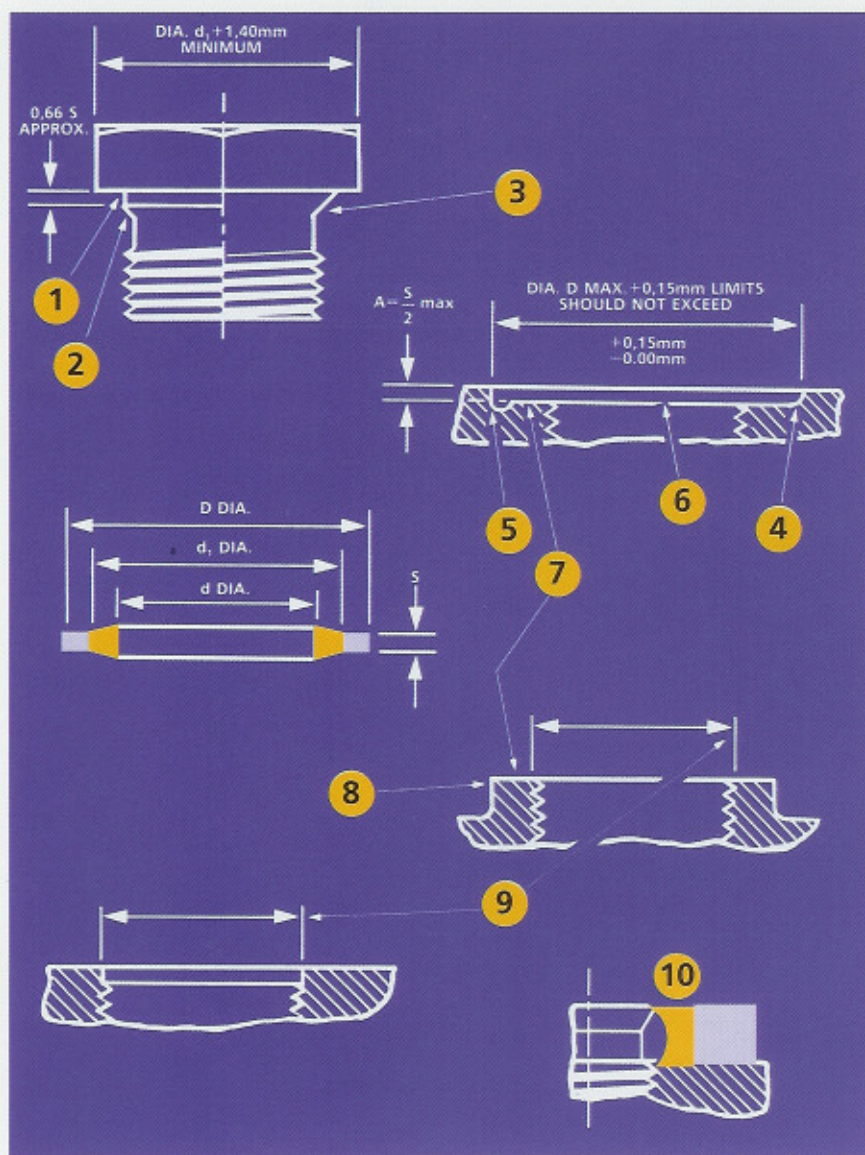

- 1 THIS DIAMETER EQUALS BASIC MAJOR THREAD DIAMETER
- 2 PLAIN SHOULDER AND ANY FORM OF UNDERCUT
- 3 TAPER NECK UNDERCUT TO BS. 1936 OR AGS OR SIMILAR STANDARD. A PARALLEL OR SEMI-CIRCULAR FORM WIDTH NOT EXCEEDING S IS ALSO ACCEPTABLE
- 4 0.15mm MAX. RADIUS
- 5 ALTERNATIVE IF LARGER CORNER RADIUS IS REQUIRED
- 6 RECESS ELIMINATING THE NEED FOR SPECIAL UNDERCUT OR SHOULDER IN MATING PART
- 7 FACE TO BE NORMAL TO THREAD WITHIN 0.08mm/25mm RUN.
- 8 BOSS DIAMETER TO BE EQUAL TO OR GREATER THAN D DIA.
- 9 THE DIAMETER OF A CHAMFER OR COUNTERBORE FOR REMOVAL OF FIRST THREAD SHOULD BE CONCENTRIC WITH AND NOT EXCEED THE THREAD DIAMETER
- 10 DIAGRAM TYPICAL OF THE ASSEMBLY AS IT SHOULD APPEAR AT ANY RADIAL SECTION i.e. RING CENTRALISED AND RUBBER IN FULL CONTACT WITH FLAT FACES.

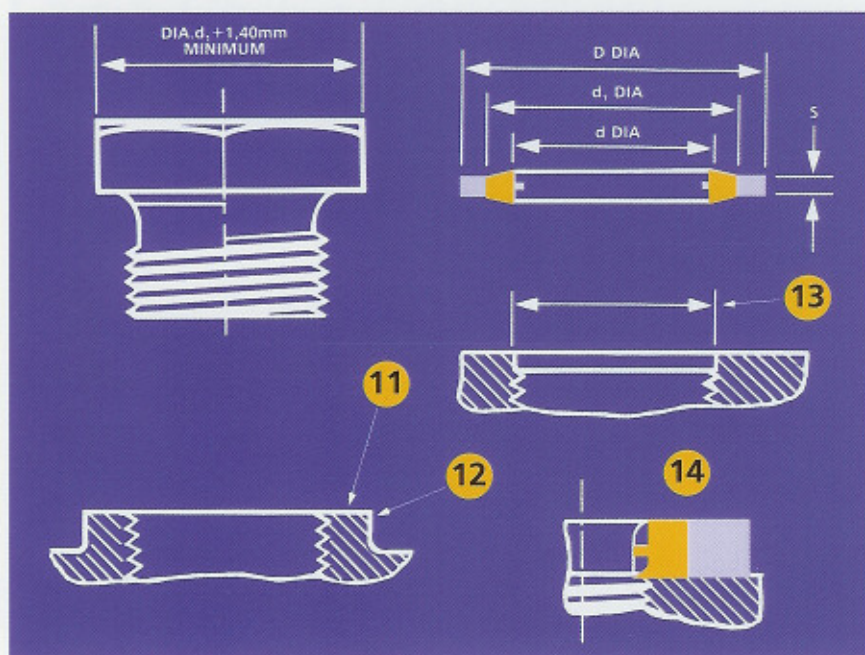

SELF CENTRING

- 11 FACE TO BE NORMAL TO THREAD WITHIN 0.08mm/25mm RUN.
- 12 BOSS DIAMETER TO BE EQUAL TO OR GREATER THAN D DIA.
- 13 THE DIAMETER OF A CHAMFER OR COUNTERBORE FOR REMOVAL OF FIRST THREAD SHOULD BE CONCENTRIC WITH AND NOT EXCEED THE THREAD DIAMETER.
- 14 DIAGRAM TYPICAL OF THE ASSEMBLY AS IT SHOULD APPEAR AT ANY RADIAL SECTION i.e. RING CENTRALISED AND RUBBER IN FULL CONTACT WITH FLAT FACES.

CAP-NUT CLOSURES

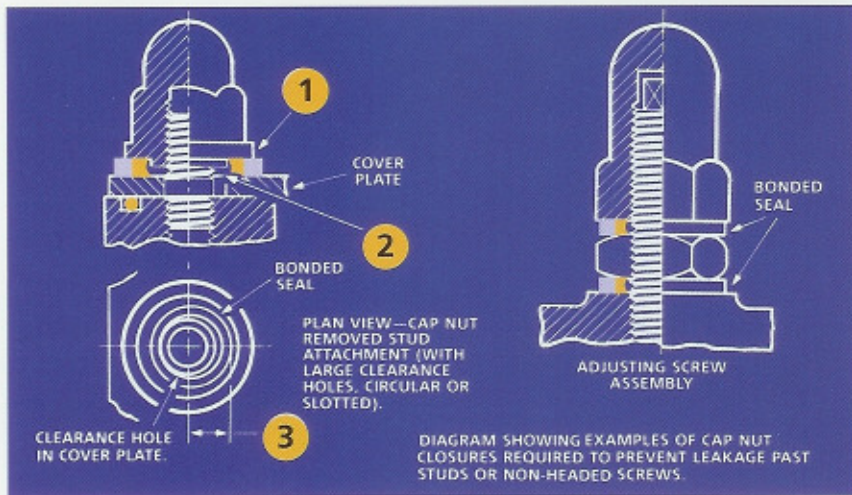

INSTALLATION FAULTS AND USAGE REMINDERS

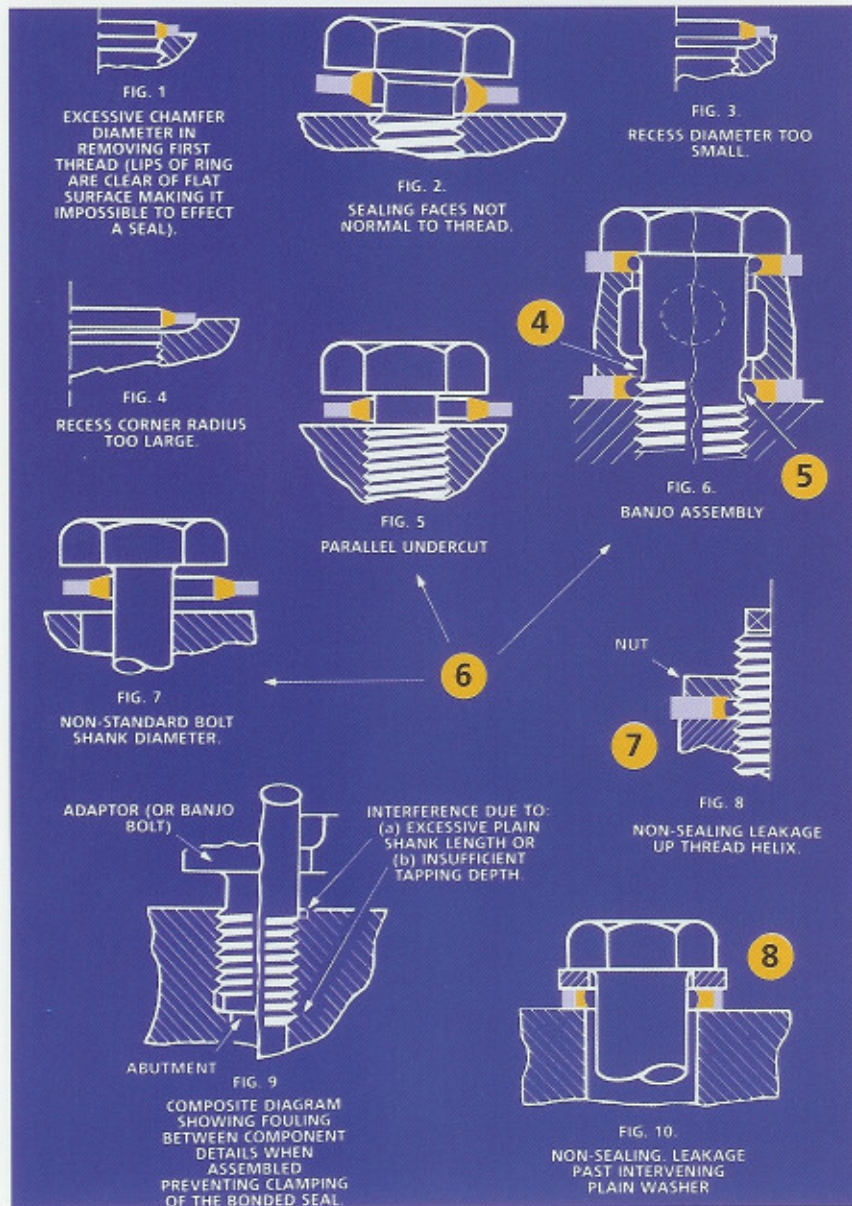

- 1 THE FLANGE DIAMETER (OR SIZE ACROSS FLATS IF THE CAP NUT IS MACHINED FROM HEXAGON BAR) SHOULD NOT BE LESS THAN THE OUTSIDE DIAMETER OF THE RUBBER RING PLUS 2.0mm.
- 2 THE SPIGOT DIAMETER SHOULD BE EQUAL TO THE INSIDE DIAMETER OF THE RUBBER RING (MIN.) MINUS 0,75mm AND THE DEPTH ABOUT TWO THIRDS METAL RING THICKNESS.
- 3 TO BE NOT GREATER THAN INSIDE RADIUS OF RUBBER RING—0.4mm.
- 4 IF AN UNDERCUT IS PREFERRED TO THREAD RUN-OUT, ENSURE POSITION IS BEYOND BONDED SEAL AS SHOWN THUS PERMITTING THE THREAD TO CENTRALISE THE RING.
- 5 AVOID HAVING UNDERCUT IN BOLT OPPOSITE BONDED SEAL.
- 6 FIGURES 5, 6, (IN PART) & 7 ILLUSTRATE CASES IN WHICH (THROUGH NON-INCORPORATION ON COMPONENT DETAILS OF MECHANICAL MEANS OF CENTRALISING) THE BONDED SEAL SHOULD BE HELD CENTRAL WHEN TIGHTENING DOWN TO ENSURE COMPLETE CIRCUMFERENTIAL LIP CONTACT WITH THE FLAT SURFACES.
- 7 IN FIGURE 8 OR OTHER SIMILAR TYPE OF ASSEMBLY, FLUID WILL LEAK UP THE THREAD HELIX AND PAST THE BONDED SEAL. TO OBTAIN A 100% SEAL THE NUT MUST BE OF THE CAP TYPE.
- 8 THIS IS INCORRECT. FLUID WILL BYPASS THE BONDED SEAL WITH RESULTANT LEAKAGE.

SURFACE FINISH

RECOMMENDATIONS

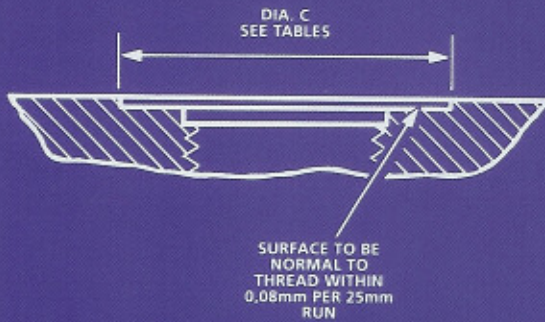

- FLUIDS AND GASES AT PRESSURES OVER 207 BAR (3000lb/in²) 0,8µm (32µin)
- FLUIDS AND GASES AT PRESSURES BELOW 207 BAR (3000lb/in²)
If lay is circular and concentric 1,6µm (64µin)
Spiral or longitudinal machined ridges 0,8µm (32µin)
- WITH PRESSURE DIE CASTING, HOT BRASS STAMPINGS AND SIMILAR DETAILS, THE SURFACE FINISH OBTAINED IS NORMALLY SATISFACTORY FOR PRESSURES BELOW 69 BAR (1000lb/in²) PROVIDED THE SURFACE IS NORMAL TO THE THREAD WITHIN 0,08mm FOR 25mm RUN.

It is important that all possible leakage paths are removed such as spiral or longitudinal machined ridges and excessive roughness. Spot facing is recommended to clean such surfaces.

TORQUE LOADING

THREAD SIZE			TORQUE REQUIRED (minimum)		FACTOR FOR TANDEM SEALING (eg BANJO ASSEMBLY)
METRIC	IMPERIAL	BSP	Nm	lbf.in	
UP TO 8	3/16		5.3	47	1.6
10	3/8	1/8	7.1	63	
11	7/16		11.8	105	
12	1/2	1/4	15.8	140	
14	3/16	.60x19	22.6	200	1.3
16	3/8	3/8	30.5	270	
18	3/4	.75x14	40.7	360	
20	.825	1/2	56.5	500	1.2
22	1/8	3/8	67.8	600	1.1
24	1		73.4	650	1
27 AND ABOVE	1.041	3/4	79	700	

'SELOC' RUBBER COVERED LOCKWASHER

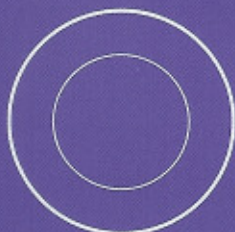

The shakeproof washer is well known for its ability to resist vibration, the effect of tightening the bolt or nut causing the metal serrations to pierce the rubber, bite into the relative metal surface and thus provide the necessary locking action. The covering of rubber reduces the risk of corrosion that would occur with a normal lockwasher by enveloping the scores in the protective treatment on the metal face to give effective protection against moisture and oxidation.

THE KEY BENEFITS

- RESISTS VIBRATION
- SUITABLE FOR PRE-BUILD ASSEMBLIES
- OPTIONS FOR WATER, MINERAL OILS AND ALKALIS
- USED ON PAINTED, PLATED AND STOVE ENAMELLED SURFACES
- TEMPERATURE RANGE -70 TO +200°C

APPLICATIONS

Material Reference	MINERAL BASED FLUIDS	NATIONAL WATER COUNCIL APPROVED	FOOD & DRUG AUTHORITY APPROVED	PETROL	MINERAL BASED ENGINE LUBRICATING OILS, DIESTER TYPE LUBRICATING OILS	HIGH TEMPERATURE APPLICATIONS	OZONE RESISTANCE	HOT AIR	POLYGLYCOL BASED FLUIDS	Polymer Base	Material Specification	Temperature Range °C	Hardness IRHD
0117	●		●	●						HIGH NITRILE		-30 to +110	65 to 75
4470	●									MEDIUM NITRILE	ASTM D2000 M2 BG S10, B14, EA14, EF11, EF21, EO14, EO34, F12, Z	-40 to +110	65 to 75
2455		●	●							MEDIUM NITRILE	ASTM D2000 M2 BG714, B14, EA14, EF11, EF21, EO14, EO34, F17, Z1, Z2	-40 to +110	65 to 75
2064							●		●	ETHYLENE PROPYLENE	ASTM D2000 M3 DA710, A26, B36 C32, EA14	-50 to +120	70 to 80
9775				●	●	●	●	●		FLUORO-CARBON	ASTM D2000 M6 HK, 81081-10, B38, EF31, EO88, Z1, Z2	-15 to +200	71 to 80
8870								●		SILICONE		-70 to +200	65 to 75
1574	●			●	●		●	●		PVC/NITRILE BLEND	AF5 920A	-10 to +80	56 to 64

PREFERRED COMPOUND

1574 also available as a released compound

ORDER REFERENCES - 'SELOC' RUBBER COVERED LOCKWASHER

Dowty Part No.

4	3	5	-	0	0	6	-	1	5	7	4	-	9	1
---	---	---	---	---	---	---	---	---	---	---	---	---	---	---

Product Reference

Size Reference

Material Reference

Metal Lock Washer

PRODUCT REFERENCE

Aerospace and Defence Released	335
Industrial Non-Released	435

SIZE REFERENCE

Select from table and insert the appropriate size reference
e.g. 006= $\frac{5}{16}$ Imperial or M8 thread size

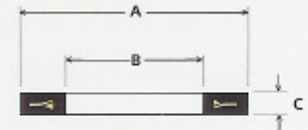

MATERIAL REFERENCE

From table, select the compound most suitable to the applicational requirements.

e.g. 4470=non-released 70 IRHD medium nitrile

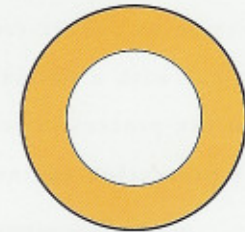

METAL LOCK WASHER

e.g. 91=metal lock washer

SIZE REFERENCE	THREAD SIZE	THREAD SIZE	OUTSIDE DIAMETER	INSIDE DIAMETER	THICKNESS
	IMPERIAL	METRIC	A	B	
001	6BA, 4UNC	2,5, 2,6	7.62	3.05	1.27
002	4BA, 6UNC	3	8.64	3.81	1.27
003	3BA, 8UNC	3,5, 4	10.16	4.32	1.40
004	2BA, $\frac{3}{16}$ in	4	11.18	4.95	1.52
005	$\frac{1}{4}$	6	13.34	6.60	1.78
006	$\frac{5}{16}$	8	16.26	8.26	1.78
007	$\frac{3}{8}$	9	18.54	9.78	2.03
008	$\frac{7}{16}$	10	21.00	11.38	2.29
009	$\frac{1}{2}$	12	23.37	13.08	2.29
010	$\frac{5}{8}$	14	25.65	14.73	2.29
011	$\frac{3}{4}$	16	28.19	16.26	2.54
012	$\frac{7}{8}$	18	32.90	19.43	2.67
013	1	22	36.58	22.86	2.79
014	1	24	42.55	26.29	3.05