

Specification

Small Form Factor Pluggable
 Duplex LC Receptacle – SFP+



C- Band Tunable
1550 nm Single Mode Optical Transceivers
 10.3125 Gbps
 Distance: 0~10 km

Model Name	Voltage	Category	Device type	Interface	SD/LOS	Temperature	Distance
BW10-1550-10-T-S10	3.3V	With DDMI	VCSEL /APD	AC / AC Coupling	LVTTTL	-20°C~+85°C	10 km (+200 pm/nm)

Table 1

Features

- Optical Interface compliant to IEEE 802.3ae-2002
- Optical Interface compliant to G.METRO draft standard
- Compliant with SFP+ MSA
- Data Rate 10.3125Gbps
- Tunable VCSEL and APD ROSA
- Applicable for 10 km SMF connection with no dispersion compensation
- LC duplex receptacle
- Low power consumption (< 1.5W)
- Hot Pluggable
- All-metal housing for superior EMI performance
- Built in digital diagnostic Functions
- ROHS Compliant

Absolute Maximum Ratings

Parameter	Symbol	Min	Typ	Max	Unit
Storage temperature	T_s	-40		85	°C
Supply voltage	V_{CC}	0		4	V
Operating Relative Humidity	-	5		95	%
Input voltage	V_{IN}	0		V_{CC}	V

Operating Conditions

Parameter	Symbol	Min	Typ	Max	Unit
Supply Voltage	V_{CC}	3.15	3.3	3.45	V
Operating Case temperature	T_c	-20		85	°C
Total Current (Transmitter + Receiver)	I_{CC}	-	300	700	mA

Transmitter Specifications ($V_{CC}=3.1V\sim 3.5V$; $T_c= 25^{\circ}C$)

Parameter	Symbol	Min	Typ	Max	Unit
Optical Characteristics					
Output Optical Power	P_{out}	-4	-1	+2	dBm
Extinction Ratio	ER	3.5	4.5	--	dB
Wavelength Range	λ_c	1531	--	1570	nm
Wavelength Tuning Range	$\Delta\lambda$	8	10	--	nm
Relative Intensity Noise	RIN	--	--	-128	dB/Hz
Output Eye	Compliant with IEEE802.3ae eye mask				
Max. P_{out} TX-DISABLE Asserted	P_{OFF}	--	--	-30	dBm
Electrical Characteristics					
Differential Input Voltage	V_{DIFF}	200	--	700	mV
Tx_Disable_Input_High	V_{DISH}	2.0	--	$V_{CC}+0.3$	V
Tx_Disable_Input_Low	V_{DISL}	0	--	0.8	V

Receiver Specifications ($V_{CC}=3.1V\sim 3.5V$; $T_c= 0^{\circ}C\sim 70^{\circ}C$ / $T_c= -40^{\circ}C\sim 85^{\circ}C$)

Parameter	Symbol	Min	Typ	Max	Unit
Optical Characteristics					
Optical Input Power (maximum) (APD)	P_{SATIN}	-10	--	--	dBm
Receiver Sensitivity in OMA (APD)	P_{SEN}			-19	dBm
Stressed Sensitivity in OMA (APD)	$P_{SEN,Str}$	--	--	-16.7	dBm
Operating Center Wavelength	λ_c	1260	--	1610	nm
LOS – Asserted	P_{SA}	-30	--		dBm
LOS – De-asserted	P_{SD}	--	--	-20	dBm
LOS – Hysteresis	P_{SH}	0.5	--	--	dB
Electrical Characteristics					
Differential Output Voltage	V_{DIFF}	300	--	800	mV
LOS Output Voltage -High	V_{SDL}	2.0	--	$V_{CC}+0.3$	V
LOS Output Voltage -Low	V_{SDH}	0	--	0.8	V

Note: Receiver sensitivity is informative. Stressed receiver sensitivity shall be measured with conformance test signal for BER = 1×10^{-12} .

Pin Definition and Descriptions

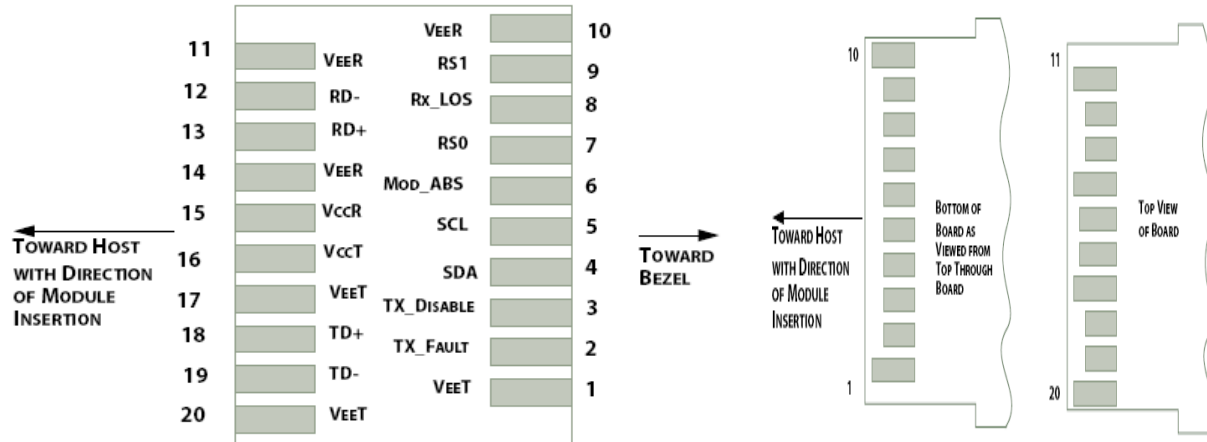

Pin	Name	Input-Output /Level	Description	Ref.
1	VEET	Power	Transmitter ground	
2	TXFault	Output	Laser failure indication (1=Laser Failure)	
3	Tx_DIS	Input/LVTTL	Transmitter Disable Control (1=Output Disable)	
4	MOD-DEF(2)	Input/Output	SDA, I2C communication data interface	
5	MOD-DEF(1)	Input	SCL, I2C communication clock interface	
6	MOD-DEF(0)	Output	Module present. Ground inside module.	
7	Rate Select 0	-	No connection.	
8	RxLOS	Output/LVTTL	Receiver loss of signal (1=Los of signal)	
9	Rate Select 1	-	No connection.	
10	VEER	Power	Receiver ground	
11	VEER	Power	Receiver ground	
12	RD-	Output/LVPECL	Inverted receiver data output	
13	RD+	Output/LVPECL	Non-inverted receiver data output	
14	VEER	Power	Receiver ground	
15	VCCR	Power	Receiver power supply	
16	VCCT	Power	Transmitter power supply	
17	VEET	Power	Transmitter ground	
18	TD+	Input/LVPECL	Transmitter non-inverted data input	

19	TD-	Input/LVPECL	Transmitter inverted data input	
20	VEET	Power	Transmitter ground	

Recommended Circuit Diagram

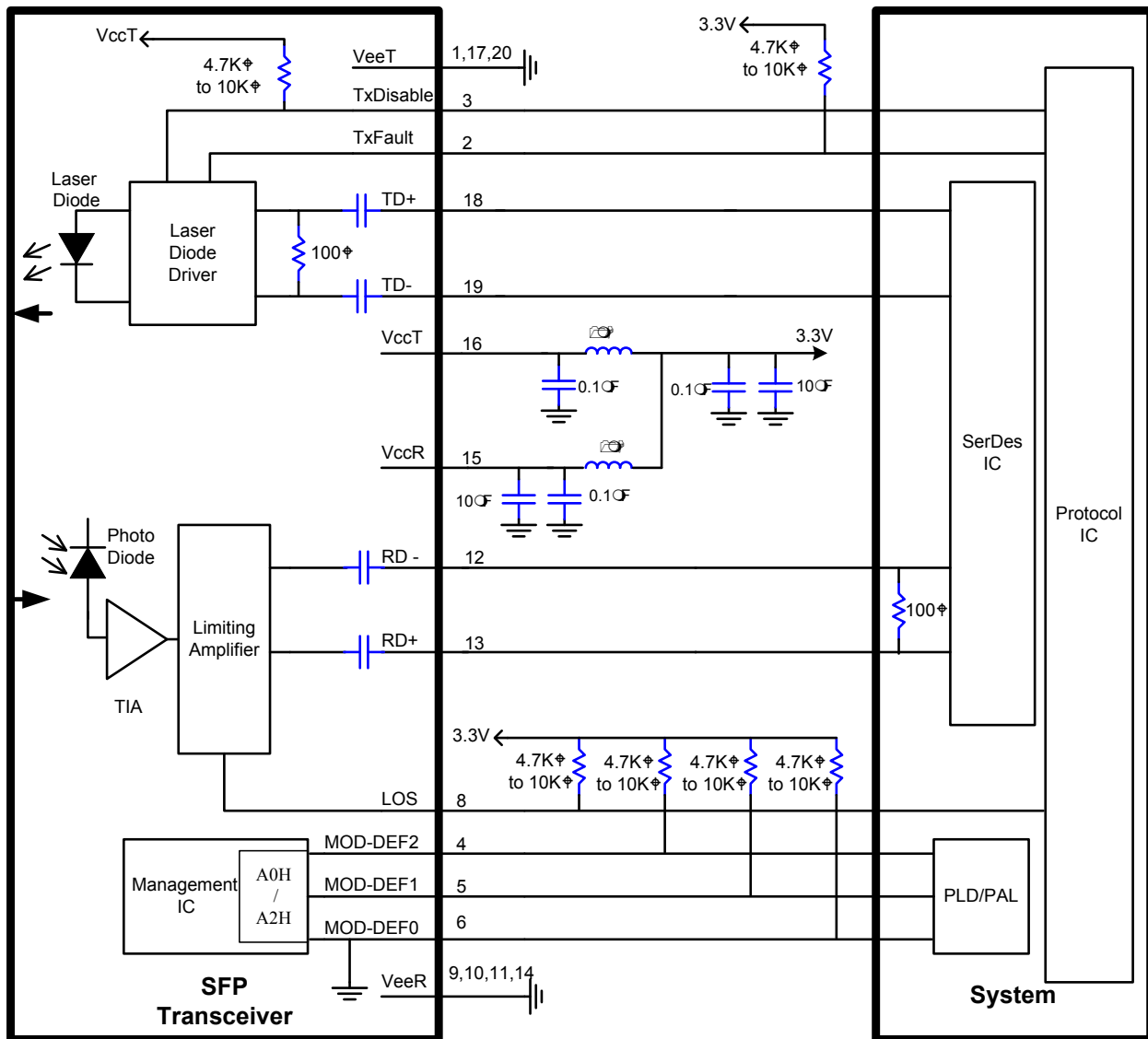

Content in 2-Wire Address A0H

Address	HEX	Name of Field	Description
00	03	Identifier	SFP
01	04	Extended Identifier	Serial ID module supported
02	07	Connector type	LC
03	00	10G Ethernet Compliance Codes	Not compliant
04	00	SONET Compliance Codes	Not compliant
05	00	SONET Compliance Codes	Not compliant
06	00	Ethernet Compliance Codes	Not compliant
07	00	Fiber Channel link length	Not compliant
08	00	Fiber Channel transmitter technology	Not compliant
09	00	Fiber Channel transmission media	Not compliant
10	00	Fiber Channel speed	Not compliant
11	06	Encoding codes	64B/66B
12	67	Nominal Bit Rate (units of 100Mbps)	10.3Gbps
13	00	Rate identifier	Unspecified
14	0A	Link length supported for 9um fiber	10 (units of km)
15	64	Link length supported for 9um fiber	100 (units of 100m)
16	00	Link length supported for 50um,OM2	N/A (units of 10m)
17	00	Link length supported for 62.5um,OM1	N/A(units of 10m)
18	00	Link length supported for copper	N/A (units of 1m)
19	00	Link length supported for 50um,OM3	N/A (units of 10m)
20 ~ 35	42,41,4E,44,57,49,44,54, 48,31,30,20,20,20,20,20	Vendor Name	BANDWIDTH10
36	00	Unallocated	
37 ~ 39	00,00,00	Vendor OUI	Unspecified
40 ~ 55	31,35,35,30,2D,31,30,2D, 54,2D,53,31,30,20,20,20	Part Number	1550-10-T-S10
56 ~ 59	00,00,00,00	Vendor Revision number	Unspecified
60 ~ 61	06,0E	Laser Wavelength	1550nm
62	00	Unallocated	
63		CC_BASE:	Check sum of byte 0 ~ 62
64	00	Options	
65	1A	Options	TX-DIS, TX_FAULT, RX-LOS
66	00	Bit Rate, max.	Unspecified
67	00	Bit Rate, min.	Unspecified
68 ~ 83	Serial Number	Serial Number	
84 ~ 89	yy/mm/dd	Date Code	
90 ~ 91	20,20	Vendor specific lot code	Unspecified
92	68	Diagnostic Monitoring Type	Internal calibration
93	F0	Enhanced Options (soft)	Alarm/Warning flags, Soft TxDisable, Soft TxFault, Soft RxLOS implemented
94	03	SFF-8472 Compliance	Rev10.2
95		CC_EXT	Check sum of byte 64 ~ 94



**SFP+ Tunable Transceiver
BW10-1550-10TGAC**

96~127	Vendor specific
--------	-----------------

Reading Tuning Information

Current channel:

Get from A4H_92.

Module tuning range:

Get from A4H_FB : Start of channel number

A4H_FC : End of channel number

Example Return data = 1Eh is channel #30 (EX: CH30 is 193.0 THz). Return data is in hex format.

Setting Channel

Step 1: Write address A2H_7C = xx (xx = 00h ~ 3Eh, total 63 channels)

Step 2: Write address A2H_7D = 33h

Step 3: Write address A2H_7E = 66h

Note: Channel is input in 2-digit hex format. For Example 1Eh is channel #30 (EX: CH30 is 193.0 THz)

Also, conformant to MSA SFF-8690 for setting the channel

Content in 2-Wire Address A2H

Add	Bytes	Name	Hex	Real Value
00-01	2	Temp High Alarm*	3C00	60°C
02-03	2	Temp Low Alarm*	EC00	-20°C
04-05	2	Temp High Warning*	3700	55°C
06-07	2	Temp Low Warning*	F100	-15°C
08-09	2	Voltage High Alarm	88B8	3.50V
10-11	2	Voltage Low Alarm	7918	3.10V
12-13	2	Voltage High Warning	86C4	3.45V
14-15	2	Voltage Low Warning	7B0C	3.15V
16-17	2	Bias High Alarm	2710	20mA
18-19	2	Bias Low Alarm	00FA	0.5mA
20-21	2	Bias High Warning	2328	18mA
22-23	2	Bias Low Warning	01F4	1mA
24-25	2	TX Power High Alarm	3E0D	2dBm
26-27	2	TX Power Low Alarm	063F	-8dBm
28-29	2	TX Power High Warning	312D	1dBm
30-31	2	TX Power Low Warning	07CF	-7dBm
32-33	2	RX Power High Alarm	03E8	-10dBm
34-35	2	RX Power Low Alarm	0027	-24dBm
36-37	2	RX Power High Warning	031A	-11dBm
38-39	2	RX Power Low Warning	0032	-23dBm
40-55	16	Reserved	00	-
56-59	4	RX_PWR(4)	00000000	0
60-63	4	RX_PWR(3)	00000000	0

64-67	4	RX_PWR(2)	00000000	0
68-71	4	RX_PWR(1)	3F800000	1
72-75	4	RX_PWR(0)	00000000	0
76-77	2	TX_I(Slope)	0100	1
78-79	2	TX_I(Offset)	0000	0
80-81	2	TX_PWR(Slope)	0100	1
82-83	2	TX_PWR(Offset)	0000	0
84-85	2	T(Slope)	0100	1
86-87	2	T(Offset)	0000	0
88-89	2	V(Slope)	0100	1
90-91	2	V(Offset)	0000	0
92-94	3	Reserved	00	-
95	1	Checksum		-

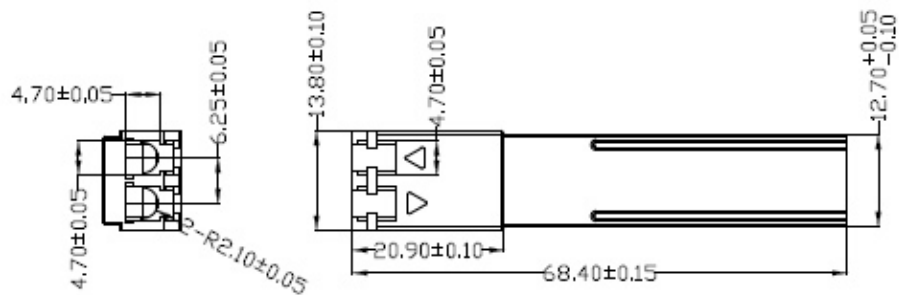
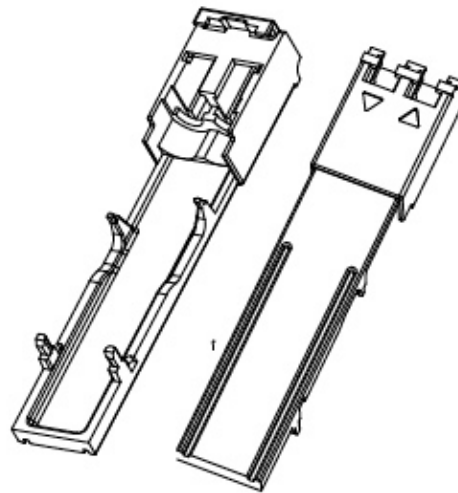
Mechanical Outlines (units: mm)

Order Information:
Part Number

BW10	-	www	-	ss	T	S	A	C
		Wave-length (see below)		Bitrate (Gbps) 01 = 1.25 02 = 2.5 10 = 10	Tunable	Feature S: Standard G: G.Metro Compliant	Receiver Type A: APD P: PIN	Temperature Grade (°C) C: 0~70 E: -20 ~ 85 I: -40 ~ 85

Wavelength Description

www	Wavelength (nm)	Frequency (THz)	Note
1550	Not specified	Not specified	
HEE0	1529.55 ~ 1544.53	196.0 ~ 194.1	
HEE1	1529.55 ~ 1536.61	196.0 ~ 195.1	
HEE2	1537.40 ~ 1544.53	195.0 ~ 194.1	
TEE0	1550.12 ~ 1565.50	193.4 ~ 191.5	
TEE1	1550.12 ~ 1557.36	193.4 ~ 192.5	
TEE2	1558.17 ~ 1565.50	192.4 ~ 191.5	