



UMR-A SERIES

125 to 6000V, 4 to 30W
Standard DC/DC Modules



Features

- Biasing High Voltage Power Supplies
- Regulated Output Voltage from V_{OUT} Max to True Zero
- Wide Input Voltage Range
- Low Ripple
- Output Short Circuit Protection
- Output Voltage and Current Monitors
- Fixed-Frequency, Low-Stored-Energy Design
- UL/cUL Recognized Component; CE Mark (LVD and RoHS)

Specifications

		Conditions			Value	Units
Input		4W	20W	30W		
Voltage	Nominal	+12	+24	+24		VDC
Voltage Range	Full Power	+11 to 16	+23 to 30	+23 to 30		VDC
Voltage Range	Derated Power Range	+10 to 32	+10 to 32	+10 to 32		VDC
Current	Standby/Disable	<80	<80	<80		mA
Current	No Load, Max V_{OUT}	<150	<150	<150		mA
Current	Full Load, Max V_{OUT}	<500	<1000	<1500		mA
AC Ripple Current	Nominal Input, Full Load	<100	<100	<100		mAp-p
Output						
Static Load Regulation	No Load to Full Load, Max V_{OUT}		<0.01			%VDC
Line Regulation	Nominal Input, Max V_{OUT} , Full Power		<0.08			%VDC
Stability	30-minute warmup, per 8h/per day		<0.01 / <0.02			%VDC
Programming & Controls						
Input Impedance	Nominal Input, Positive Models	1.0 to Signal Ground			M Ω	
	Nominal Input, Negative Models	0.01 to V_{REF}				
Adjust Resistance	Typical Potentiometer Values	10K to 100K (Pot Across V_{REF} and Signal Ground, Wiper to Adjust)			Ω	
Adjust Logic (V_{ADJ})¹	Positive Models	0 to +4.64 = 0 to 100% Rated Output			VDC	
	Negative Models	+5 to +0.36 = 0 to 100% Rated Output				
Reference Voltage (V_{REF})	Temperature +25°C	+5 \pm 0.5%			VDC	
Enable/Disable HV_{OUT}	-	Unconnected = Enabled Ground to +0.5 = Disabled; +2.4 to 32 = Enabled			VDC	
Environmental						
Operating Temperature²	Case Temperature, Full Load, Max V_{OUT}	-40 to +65			$^{\circ}$ C	
Temperature Coefficient	Over the Specified Temperature	\pm 50			PPM/ $^{\circ}$ C	
Thermal Shock	Mil-Std-810, Method 503-4, Proc. II	-40 to +65			$^{\circ}$ C	
Storage Temperature	Non-Operating, Case Temperature	-55 to +105			$^{\circ}$ C	
Humidity	All Conditions, Standard Package	0 to 95% Non-Condensing			-	
Altitude	All Conditions, Standard Package	Sea Level through Vacuum			-	
Shock	Mil-Std-810, Method 516.5, Proc IV	20			G	
Vibration	Mil-Std-810, Method 514.5, Fig 514.5C-3	10			G	

¹V05 or V10 Options (additional details on pg.4)

²Typically, convection cooled. Units operating at full power might require additional cooling to maintain case temperature below 65°C. Damage to the power supply may occur if not appropriately cooled during use.



UMR-A SERIES

Part Number ³	Output Voltage VDC	Output Current mA	High Frequency Ripple ⁴ %Vp-p		Output Capacitance μF		I _{MON} Scaling ⁵ mA/V	V _{MON} Scaling ⁶ V
			Base	Option F	Base	Option F		
4W Models								
UMR-A-125•-4	0 to 125	32.00	0.029	0.0030	1.0000	1.300	438	10:1 ±2%
UMR-A-250•-4	0 to 250	16.00	0.010	0.0030	1.0000	1.300	213	10:1 ±2%
UMR-A-500•-4	0 to 500	8.00	0.007	0.0010	0.0500	0.080	123	10:1 ±2%
UMR-A-1000•-4	0 to 1000	4.00	0.028	0.0015	0.0100	0.030	56	100:1 ±2%
UMR-A-2000•-4	0 to 2000	2.00	0.015	0.0030	0.0050	0.030	32	100:1 ±2%
UMR-A-4000•-4	0 to 4000	1.00	0.015	0.0020	0.0050	0.015	17	100:1 ±2%
UMR-A-6000•-4	0 to 6000	0.67	0.021	0.0025	0.0033	0.010	13	100:1 ±2%
20W Models								
UMR-A-125•-20	0 to 125	160.0	0.040	0.0050	8.9000	9.200	1900	10:1 ±2%
UMR-A-250•-20	0 to 250	80.0	0.021	0.0030	1.0000	1.300	1000	10:1 ±2%
UMR-A-500•-20	0 to 500	40.0	0.019	0.0010	1.0000	1.300	506	10:1 ±2%
UMR-A-1000•-20	0 to 1000	20.0	0.048	0.0015	0.0500	0.080	244	100:1 ±2%
UMR-A-2000•-20	0 to 2000	10.0	0.026	0.0030	0.0100	0.030	130	100:1 ±2%
UMR-A-4000•-20	0 to 4000	5.0	0.030	0.0020	0.0050	0.015	67	100:1 ±2%
UMR-A-6000•-20	0 to 6000	3.3	0.039	0.0025	0.0033	0.010	49	100:1 ±2%
30W Models								
UMR-A-125•-30	0 to 125	240.0	0.040	0.0050	8.9000	9.200	2900	10:1 ±2%
UMR-A-250•-30	0 to 250	120.0	0.033	0.0035	1.0000	1.300	1400	10:1 ±2%
UMR-A-500•-30	0 to 500	60.0	0.020	0.0010	1.0000	1.300	740	10:1 ±2%
UMR-A-1000•-30	0 to 1000	30.0	0.048	0.0015	0.0500	0.080	400	100:1 ±2%
UMR-A-2000•-30	0 to 2000	15.0	0.036	0.0030	0.0100	0.030	212	100:1 ±2%
UMR-A-4000•-30	0 to 4000	7.5	0.036	0.0020	0.0050	0.015	86	100:1 ±2%
UMR-A-6000•-30	0 to 6000	5.0	0.045	0.0025	0.0033	0.010	57	100:1 ±2%

³For "•", substitute "P" for positive output or "N" for negative output

⁴1Hz to 1MHz

⁵Full Scale Signal

⁶Into 10MΩ Meter for Models with Y05 Option and F Option.

Options

Append to Part #	Option Description	Not Compatible With
-V05	Enhanced Controls and Monitors, 0 to +5VDC	V10, Y05
-V10	Enhanced Controls and Monitors, 0 to +10VDC	V05, Y05, 4W models
-Y05	Output Voltage Monitor	-
-H	Aluminum Heat Sink	E, C
-F	Integral Output Filter	Y05
-T	±25PPM/°C Temperature Coefficient ⁷	-
-W	Flying Lead for High Voltage Output	-
-M	Mu-Metal Shielding Over Case	-
-E	Eared Mounting Plate	H

⁷Operating Temperature is +10 to +45°C.

Mechanical Drawings and Pin Assignments

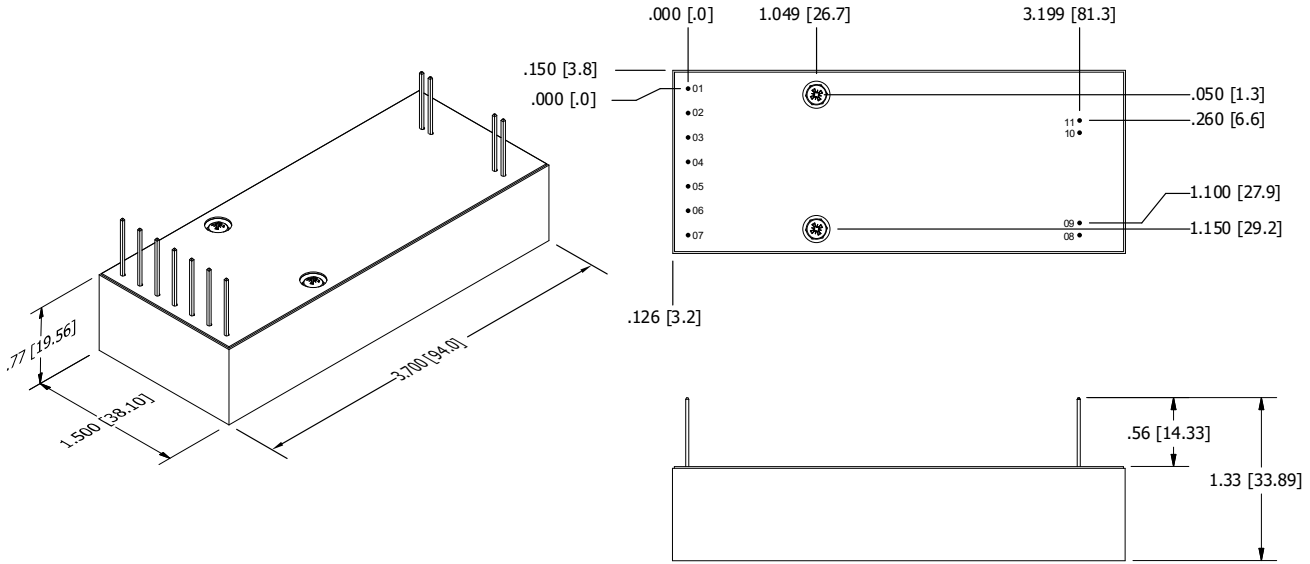

Dimensions in inches [mm]

Mechanical Specifications	
Volume	4.3in ³ [70.5cm ³]
Weight	5.0oz [142g]
Case	DAP case certified to ASTM-D-5948
Pins	<i>Size</i> 0.025" [0.635mm] square
	<i>Spacing</i> Pins 1-7 0.200in Pins 8-9, 10-11 0.100in

Tolerances	
Overall	0.050in [±1.27mm]
Pin to Pin	0.015in [±0.38mm]
Mounting	0.025in [±0.64mm]

Pin Assignments & Connections		
Pin 1	PWRGND ⁸	Input Power Ground Return
Pin 2	+VIN	Positive Power Input
Pin 3	IMON ⁸	Output Current Monitor
Pin 4	ENABLE	Enable/Disable
Pin 5	SIGGND	Signal Ground Return
Pin 6	VADJ ⁸	Voltage Adjust
Pin 7	VREF	Voltage Reference
Pin 8, 9	HVRTN ⁹	High Voltage Ground Return
Pin 10,11	HVOUT	High Voltage Output

⁸PWRGND may be labelled -VIN, IMON as IOUT, and VADJ as RMTADJ on some models.

⁹Pin 9 becomes VMON - Output Voltage Monitor for the Y05 Option.



UMR-A SERIES

V05 and V10 Options

Conditions		Value	Units
Output			
Current Scaling (I_{MON})	V05 Option, Buffered Signal	0 to +5 = 0 to 100% Rated Output	VDC
	V10 Option, Buffered Signal	0 to +10 = 0 to 100% Rated Output	
Voltage Scaling (V_{MON})	V05 Option, Buffered Signal	0 to +5 = 0 to 100% Rated Output	VDC
	V10 Option, Buffered Signal	0 to +10 = 0 to 100% Rated Output	
Programming & Controls			
Adjust Logic (I_{ADJ} & V_{ADJ})	V05 Option	0 to +5 = 0 to 100% Rated Output	VDC
	V10 Option	0 to +10 = 0 to 100% Rated Output	
Reference Voltage (V_{REF})	V05 Option	+5 \pm 0.5%, 10mA Source	VDC
	V10 Option	+10 \pm 0.5%, 30mA Source	
Enable/Disable HV_{OUT}	-	Unconnected = Disabled; Ground to +0.5 = Disabled; +2.4 to 32 = Enabled	VDC
Mode Indicator	IMODE	Open Drain, Pulled Low When Active, 0 to 60V and 100mA Max	-
	VMODE	Open Drain, Pulled Low When Active, 0 to 60V and 100mA Max	

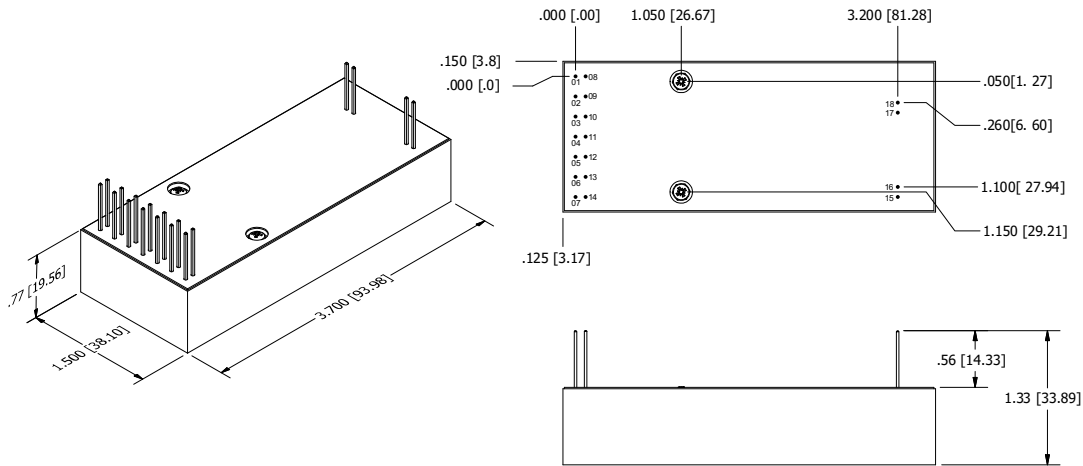

Mechanical Specifications	
Volume	4.3in ³ [70.5cm ³]
Weight	5.0oz [142g]
Case	DAP case certified to ASTM-D-5948
Pins	Size 0.025" [0.635mm] square
	Spacing Pins 1-7, 8-14 0.200in Pins 15-16, 17-18 0.100in

Tolerances	
Overall	0.050in [\pm 1.27mm]
Pin to Pin	0.015in [\pm 0.38mm]
Mounting	0.025in [\pm 0.64mm]

Pin Assignments & Connections		
Pin 1, 8	PWRGND ¹⁰	Input Power Ground Return
Pin 2, 9	+VIN	Positive Power Input
Pin 3	IMON	Output Current Monitor
Pin 4	ENABLE	Enable/Disable
Pin 5	SIGGND	Signal Ground Return
Pin 6	VADJ	Voltage Adjust
Pin 7	VREF	Voltage Reference
Pin 10	N/C	N/C
Pin 11	IMODE	Current Mode Indicator
Pin 12	VMODE	Voltage Mode Indicator
Pin 13	IADJ	Current Adjust
Pin 14	VMON	Output Voltage Monitor
Pin 15, 16	HVRTN	High Voltage Ground Return
Pin 17, 18	HVOUT	High Voltage Output

¹⁰PWRGND may be labelled -VIN on some models.

F Option

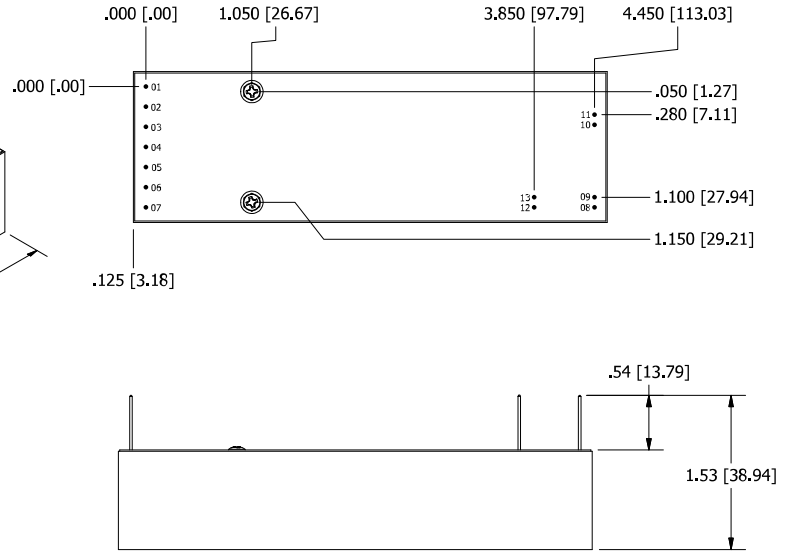
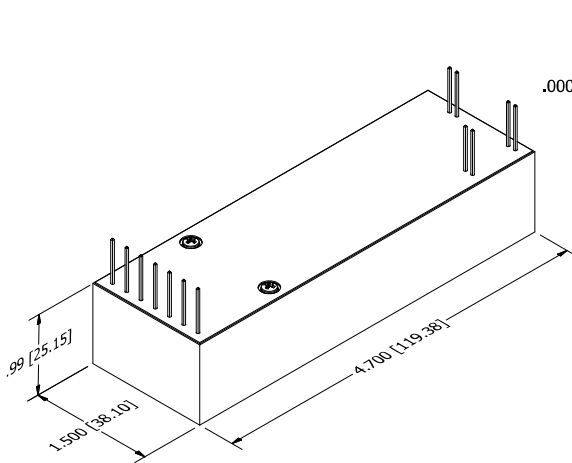

Dimensions in inches [mm]

Mechanical Specifications	
Volume	7.0in ³ [114cm ³]
Weight	7.6oz [215g]
Case	DAP case certified to ASTM-D-5948
Pins	<i>Size</i> 0.025" [0.635mm] square
	<i>Spacing</i> Pins 1-7 0.200in Pins 8-9, 10-11, 12-13 0.100in

Tolerances	
Overall	0.050in [±1.27mm]
Pin to Pin	0.015in [±0.38mm]
Mounting	0.025in [±0.64mm]

Pin Assignments & Connections		
Pin 1	PWRGND ¹¹	Input Power Ground Return
Pin 2	+VIN	Positive Power Input
Pin 3	IMON ¹¹	Output Current Monitor
Pin 4	ENABLE	Enable/Disable
Pin 5	SIGGND	Signal Ground Return
Pin 6	VADJ ¹¹	Voltage Adjust
Pin 7	VREF	Voltage Reference
Pin 8, 9	HVRTN	High Voltage Ground Return
Pin 10,11	HVOUT	High Voltage Output
Pin 12, 13	VMON	Output Voltage Monitor

¹¹PWRGND may be labelled -VIN, IMON as IOUT, and VADJ as RMTADJ on some models.



UMR-A SERIES

V-F Option

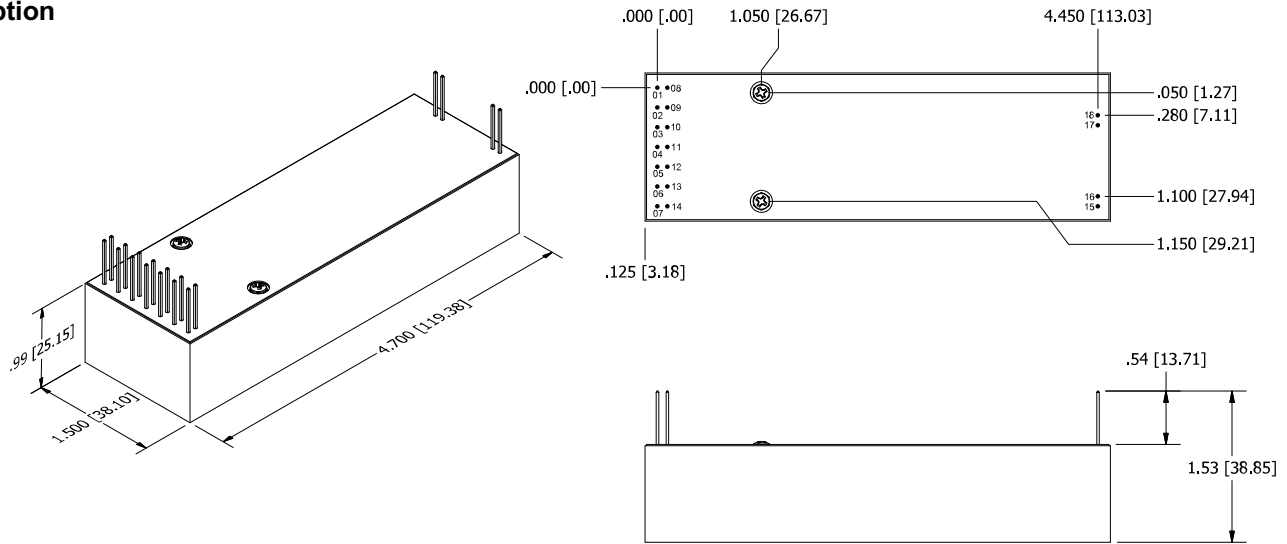

Dimensions in inches [mm]

Mechanical Specifications	
Volume	7.0in ³ [114cm ³]
Weight	7.6oz [215g]
Case	DAP case certified to ASTM-D-5948
Pins	<i>Size</i> 0.025" [0.635mm] square
	<i>Spacing</i> Pins 1-7, 8-14 0.200in Pins 15-16, 17-18 0.100in

Tolerances	
Overall	0.050in [±1.27mm]
Pin to Pin	0.015in [±0.38mm]
Mounting	0.025in [±0.64mm]

Pin Assignments & Connections		
Pin 1, 8	PWRGND ¹²	Input Power Ground Return
Pin 2, 9	+VIN	Positive Power Input
Pin 3	IMON ¹²	Output Current Monitor
Pin 4	ENABLE	Enable/Disable
Pin 5	SIGGND	Signal Ground Return
Pin 6	VADJ ¹²	Voltage Adjust
Pin 7	VREF	Voltage Reference
Pin 10	N/C	N/C
Pin 11	IMODE	Current Mode Indicator
Pin 12	VMODE	Voltage Mode Indicator
Pin 13	IADJ	Current Adjust
Pin 14	VMON	Output Voltage Monitor
Pin 15, 16	HVRTN	High Voltage Ground Return
Pin 17, 18	HVOUT	High Voltage Output

¹²PWRGND may be labelled -VIN, IMON as IOUT, and VADJ as RMTADJ on some models.

Certifications and Compliances

