

INSTRUCTION MANUAL

ELECTRIC DIESEL PUMP KIT

AFP12A (12volt / Automatic Nozzle) | AFP12M (12volt / Manual Nozzle)
AFP24A (24volt / Automatic Nozzle) | AFP24M (24volt / Manual Nozzle)



ELECTRIC DIESEL PUMP KIT

AFP12A (12volt / Automatic Nozzle) | AFP12M (12volt / Manual Nozzle)
AFP24A (24volt / Automatic Nozzle) | AFP24M (24volt / Manual Nozzle)

INTRODUCTION

Thank you for purchasing a Macnaught 12 or 24 volt Electric Diesel Fuel Pump.

The Macnaught Electric Diesel Fuel Pump kit is supplied, complete with either a Manual or Automatic Fuel Nozzle, 2m x 3/4" Suction Hose, 4m x 3/4" Delivery Hose and 4M power cable with fuse holder and alligator clips.



GENERAL INFORMATION

This manual assists you in operating and maintaining your electric diesel fuel pump. The information contained will help ensure many years of dependable trouble free operation.

DESCRIPTION

This diesel transfer pump is designed to reliably transfer diesel. The pump is a self priming, positive displacement, rotary vane pump operating on either 12 or 24V DC depending on the model. The pump will deliver up to 40 litres per minute, has a built-in bypass valve that keeps the operating pressure below 1.3 Bar (18 psi) and the motor has a **30 minute duty cycle**

If you require a fuel filter or meter for your pump, Macnaught recommends that you use the Macnaught HA1S-01 fuel filter and/or select one of the Macnaught fuel meters.



CAUTION

ONLY USE this pump with Diesel,

Failure to do so may cause personal injury or damage the pump which voids pump warranty.

Please read and retain this instruction manual to assist you in the operation and maintenance of this quality product. If you require any further assistance please contact your local Macnaught distributor.



WARNING

This pump must not be used in bypass mode (nozzle closed) for more than 2 minutes other wise serious damage to the motor will occur.

An inline fuse with the same rating to the one fitted to electric cable on this pump must fitted and used at all times otherwise pump warranty will be void.

ASSEMBLY

Use oil resistant pipe sealant or Teflon® tape on all pipe threads.

1. Fit the strainer supplied to the end of blue suction hose and secure with the hose clamp supplied.
2. Fit the 3/4" hose tail to the remaining end of the suction hose and secure with the hose clamp supplied.
3. Connect the suction hose assembly to the pump inlet (refer to direction of flow on pump)
4. Connect the delivery hose to the outlet on the pump.
5. Fit the swivel to the delivery hose and fit the nozzle with the supplied swivel.

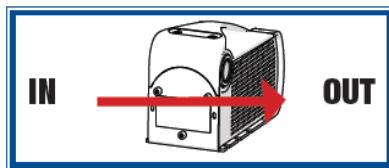

PUMP INSTALLATION

Note:

The pump should be sheltered from rain and weather events

This motor is not explosion proof



ELECTRIC DIESEL PUMP KIT

AFP12A (12volt / Automatic Nozzle) | AFP12M (12volt / Manual Nozzle)
AFP24A (24volt / Automatic Nozzle) | AFP24M (24volt / Manual Nozzle)

1. Position the pump assembly securely.

NOTE: Ensure the pump is positioned to a secure location.

2. Insert the suction hose with suction strainer fitted into the fuel tank.

NOTE: Tanks or barrels should be anchored to prevent tipping in both the full and empty conditions.

NOTE: Maximum suction distance no more than 2 meters

3. Connect the battery clips power cord to a suitable battery which is capable of delivering the necessary voltage and current (see the Technical Data, back page of this manual)

a) Attach the RED clip to the positive (+) battery terminal.

b) Attach the BLACK clip to the negative (-) battery terminal or to the vehicle frame.

OPERATION

NOTE: Avoid sparks that could cause a fire:

DO NOT use a patch cord to extend the power cables.

DO NOT let the pump run dry for more than **2 minutes** or damage may occur

1. Before use, wipe off any dirt or moisture that may have accumulated on the nozzle or hoses.

2. Insert nozzle into the container to be filled. Insert suction hose (if applicable) into the diesel storage tank.

3. Switch the motor on.

4. Operate the nozzle lever to dispense fluid.

5. When the desired amount of fluid has been dispensed, release nozzle lever to stop flow.

6. Immediately switch motor off.

7. Nozzle and hoses should be kept clean and dry when not in use.

NOTE: If the pump fails to prime, remove nozzle, turn pump on to prime then re-fit nozzle

MAINTENANCE

IMPORTANT

DO NOT modify any part of the unit or any warranty on the product will be automatically void.

1. Inspect and clean the strainer on the suction bottom of the hose / pipe regularly.

2. Always clean the battery terminals and clips before use to ensure a good connection.

3. Always relieve the line pressure by opening the nozzle, draining hose. Disconnect power before starting any pump maintenance

4. Hoses should be inspected regularly.
(Replace if found to be cracked or worn)

5. The rotor and vanes will eventually wear. They should be replaced if pump performance degrades.
(refer to trouble shooting guide)

Electric cable selection table (minimum requirement)

Pump Model	Fluid	Flow Rate	Power Supply	Fuse	Total Cable Length	Minimum Wire Section	
AFP12A/M	Diesel	40 LPM	12 VDC	30A	0 - 4 m	2.5 mm ²	13 AWG
					4 - 6 m	4 mm ²	11 AWG
					4 - 8 m	6 mm ²	9 AWG
AFP24A/M	Diesel	40 LPM	12VDC	15A	0 - 4 m	2.5 mm ²	13 AWG
					4 - 8 m	4 mm ²	11 AWG
AHP85L-12V	Diesel	85 LPM	12VDC	30A	0 - 4 m	6 mm ²	9 AWG
					4 - 6 m	10 mm ²	7 AWG
					6 - 10 m	16 mm ²	5 AWG

ELECTRIC DIESEL PUMP KIT

AFP12A (12volt / Automatic Nozzle) | AFP12M (12volt / Manual Nozzle)

AFP24A (24volt / Automatic Nozzle) | AFP24M (24volt / Manual Nozzle)

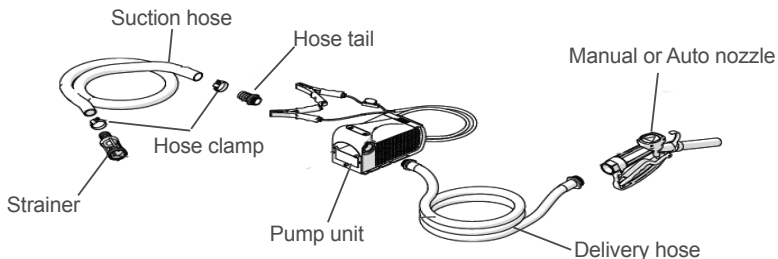

PARTS DIAGRAM

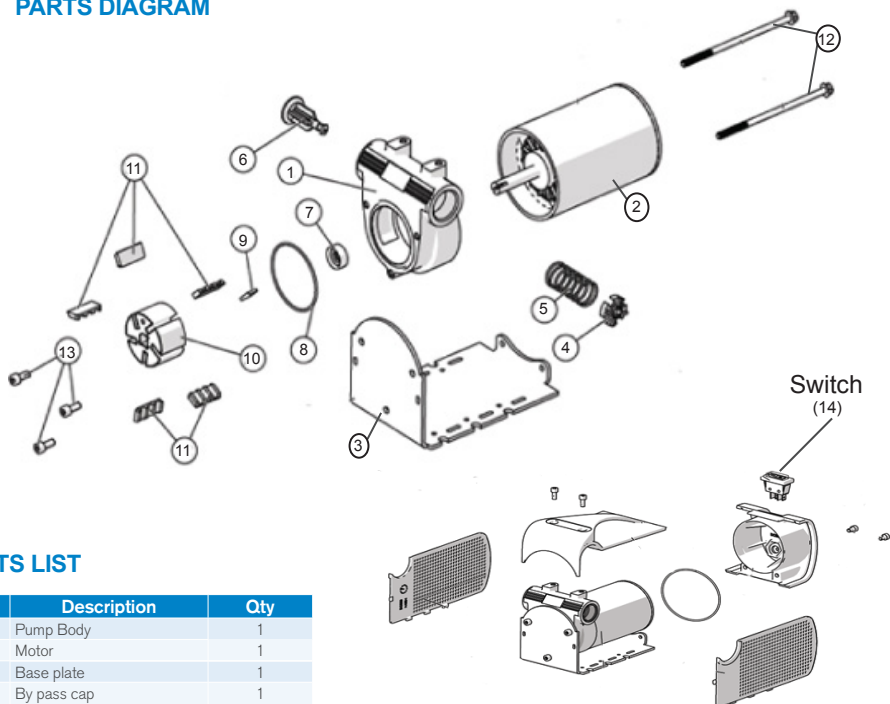

PARTS LIST

Item	Description	Qty
1	Pump Body	1
2	Motor	1
3	Base plate	1
4	By pass cap	1
5	By pass spring	1
6	By pass valve	1
7	Pump seal	1
8	O'ring	1
9	Drive key	1
10	Rotor	1
11	Vane Set	5
12	Tie rod screws	2
13	Face plate screws	3
14	Switch	1

AVAILABLE ACCESSORIES

- Manual nozzle
- Automatic nozzle
- Delivery hose
- Telescopic suction tube with strainer - ATS205
- For wet seal kit order AFP12-1K
- For poppet valve set order AFP12-2K

ELECTRIC DIESEL PUMP KIT

AFP12A (12volt / Automatic Nozzle) | AFP12M (12volt / Manual Nozzle)

AFP24A (24volt / Automatic Nozzle) | AFP24M (24volt / Manual Nozzle)

(Correct seal orientation)

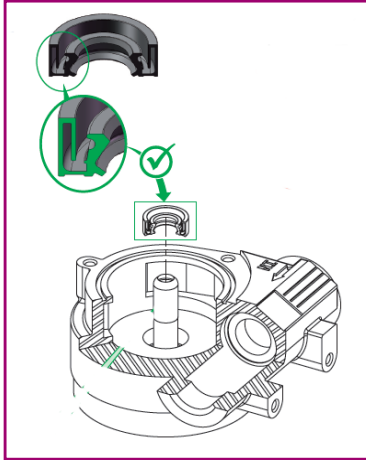

(Poppet valve assembly / disassembly)

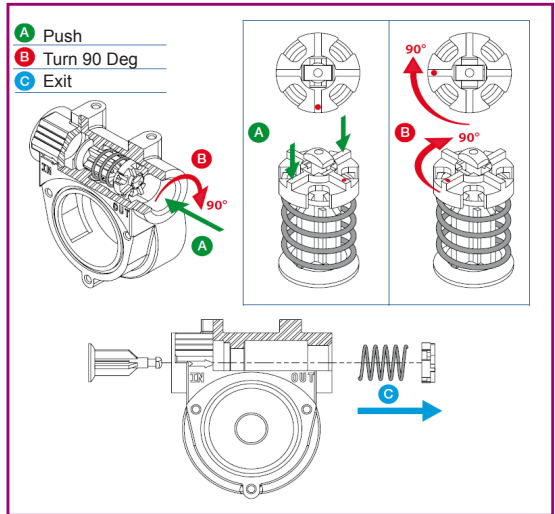

(Correct vane and rotor orientation)

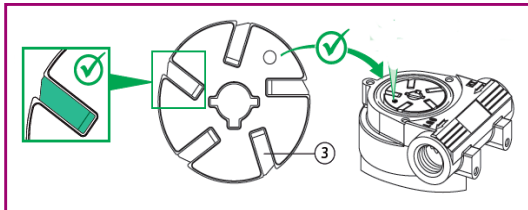

PUMP DIMENSIONS

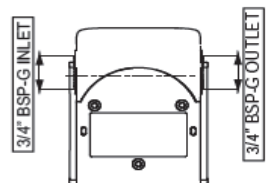
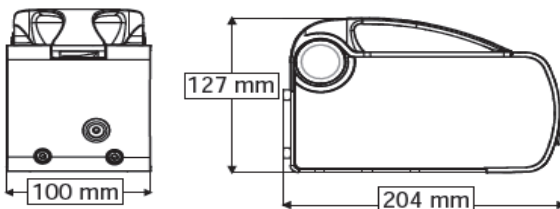



ELECTRIC DIESEL PUMP KIT

AFP12A (12volt / Automatic Nozzle) | AFP12M (12volt / Manual Nozzle)**AFP24A (24volt / Automatic Nozzle) | AFP24M (24volt / Manual Nozzle)**

TROUBLE SHOOTING GUIDE

Problem	Cause	Solution
Pump fails to start	1) Suction hose/tube has a blockage	1) Clear blockage from suction hose/tube
	2) Outlet is blocked	2) Check outlet hose and nozzle for blockage and correct operation
	3) Bypass poppet not closing	3) Check bypass valve is closing correctly
	4) Vanes sticking	4) Check vanes are sliding freely in the slots (remove burrs or replace vanes if required)
	5) Excessive vane or rotor wear	5) Replace rotor and/or vanes
	6) Leak from front o'ring	6) Check o'ring for correct sealing, replace if required
Pump vibrates but does not turn on	1) Dirt jammed inside the pump	1) Clean pump chamber
	2) Faulty motor	2) Replace pump
	3) Broken drive key	3) Replace drive key
Low Flow	1) Blocked strainer	1) Clean or replace strainer
	2) Restriction on the inlet or outlet	2) Incorrect size hoses used on inlet or outlet
	3) Excessive rotor or vane wear	3) Replace worn or damaged components
	4) By pass poppet blocked	4) Check poppet valve for correct operation
	5) Low fluid level in tank	5) Fill tank
Motor overheating	1) Fluid too thick (viscous)	1) Fluid to be no thicker than Diesel
	2) Motor running longer than 30 minutes	2) Pump must only run for 30 minutes before cooling
	3) Blocked suction hose	3) Clean blockage from suction hose
	4) Blocked strainer	4) Clean strainer
Motor not turning on	1) Poor electrical connection	1) Clean terminals and battery clamps
	2) Battery low or faulty	2) Check battery
	3) Blown or faulty fuse	3) Check pump and/or replace fuse
	4) Faulty switch	4) Replace switch
Pump leaking out of weep hole	1) Worn or damaged shaft seal	1) Replace seal
	2) Fluid compatibility	2) Only use compatible fluid



ELECTRIC DIESEL PUMP KIT

AFP12A (12volt / Automatic Nozzle) | AFP12M (12volt / Manual Nozzle)

AFP24A (24volt / Automatic Nozzle) | AFP24M (24volt / Manual Nozzle)

SPECIFICATIONS

	AFP12	AFP24
Maximum Flow	40ltr/min	40ltr/min
Maximum pressure	1.3bar	1.3bar
Voltage	12 Volt	24 Volt
Current	18 amp	12 amp
Duty cycle	30 min	30 min
Fuse	30 amp	15 amp
Inlet / Outlet	3/4" BSP (F)	3/4" BSP (F)
Temperature	-20 deg C / +50 deg C	
Wetted materials	Cast iron, Sintered steel, POM, NBR	
Maximum prime height	2m	2m
Motor protection rating	IP55	IP55

Note:

This product should be disposed of according to all applicable local and national government environment regulations and guidelines.



macnaught

Built to last since 1948.

Macnaught Pty Ltd
41-49 Henderson Street
Turrella NSW 2205

Ph: 1800 185 102
Fax: 1800 186 402
E-mail: info@macnaught.com.au

For Warranty Terms and Conditions see www.macnaught.com.au
For a list of Australian Service Centres see www.macnaught.com.au