



**PFEUFFER**

# Operating instructions



Malt friability measuring instrument

## Friabilimeter

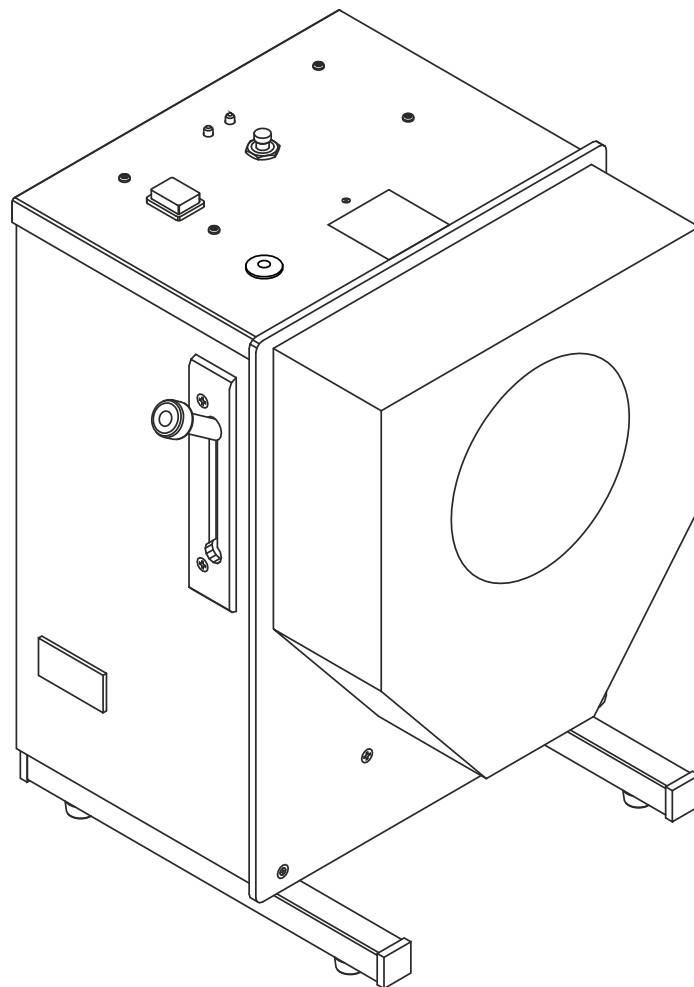

**PFEUFFER GmbH**

Flugplatzstraße 70  
97318 Kitzingen  
GERMANY

Phone: +49 9321 9369-0

info@pfeuffer.com  
www.pfeuffer.com

Revision 8.2/14.02.2024

Translation of the original operating instructions

Item number operating instructions:  
Artikelnummer Betriebsanleitung:

**1810 0091**



These Operating Instructions are a constituent part of the FRIABILIMETER and must be available to all operating personnel at all times. They are intended for the operating company of the system, the operating personnel and the specialists who are responsible for the transport, assembly, installation, operation, maintenance, cleaning, disassembly and disposal.

The Pfeuffer GmbH has prepared and reviewed these Operating Instructions with the greatest care. However, no guarantee is made for its completeness or accuracy.

Subject to technical modifications.

### **Translation**

In the event of delivery of subsequent sale to the countries of the European Economic Area (EEA), the operating instructions must be translated into the corresponding language of the country of use. In the event of discrepancies in the translated text, the original operating instructions (German) must be used for clarification, or the manufacturer must be contacted.

### **Operating instructions in electronic format**

The original operating instructions (German) and translations of the original operating instructions can be requested as PDF files by e-mail. Specifying the correct type designation and serial number is important for further processing!

### **© Copyright**

This document is not allowed to be communicated or duplicated, utilized without express permission, which also applies to communicating its content. Offenders are liable to the payment of damages. All rights reserved with regard to patent claims or submission of design or utility patent.

(DIN ISO 16016)

<b>1</b>	<b>Introduction .....</b>	<b>5</b>
1.1	Designated use .....	5
1.2	EC/EU Declaration of Conformity .....	6
1.3	Structural features of the danger notes .....	7
1.4	Pictograms in the operating instructions.....	7
1.5	Abbreviations in electrical engineering .....	8
1.6	Identification .....	8
<b>2</b>	<b>Safety.....</b>	<b>8</b>
2.1	Built-in safety systems .....	8
2.2	Electrical connections .....	11
2.3	Operating and danger areas on the FRIABILIMETER.....	11
2.4	Operating and maintenance personnel .....	11
2.5	Safety measures (to be carried out by the owner) .....	12
2.6	General safety notes .....	13
2.7	Safety tests.....	13
2.8	Residual dangers in connection with the FRIABILIMETER .....	13
2.9	Switch-off procedure .....	13
<b>3</b>	<b>Technical data .....</b>	<b>14</b>
3.1	Dimensions and weight.....	14
3.2	Power supply.....	14
3.3	General data.....	14
<b>4</b>	<b>Delivery, transport and storage.....</b>	<b>15</b>
4.1	Scope of delivery .....	15
4.2	Transport and packaging.....	15
4.3	Intermediate storage .....	15
4.4	Unpacking and packing .....	15
<b>5</b>	<b>Installation and commissioning.....</b>	<b>17</b>
<b>6</b>	<b>Function .....</b>	<b>18</b>
6.1	Overview .....	18
6.2	Sequence of functions.....	18
<b>7</b>	<b>Operation.....</b>	<b>19</b>
7.1	Control elements.....	19
7.1.1	Main switch ON/OFF.....	19
7.1.2	Pull handle .....	19
7.1.3	Setscrew.....	19
7.1.4	Start key .....	19
7.1.5	Operating hours counter .....	19

7.2	Preparations .....	20
7.3	Weighing out the sample .....	21
7.4	Filling the sample .....	21
7.5	Switching on the FRIABILIMETER .....	21
7.6	Emptying the sample.....	23
7.7	Evaluation.....	24
	7.7.1 Friability M .....	24
	7.7.2 Whole hyaline (whole grains) WH .....	24
	7.7.3 Part hyaline (partially non-comminuted grains) PH.....	25
7.8	Switching off the FRIABILIMETER .....	25
<b>8</b>	<b>Checking the device settings .....</b>	<b>26</b>
8.1	Timer runtime .....	26
8.2	Abrasion on the pressure roll.....	26
8.3	Abrasion on the drive rolls .....	27
8.4	Sieve drum.....	27
8.5	Precise adjustment using the setscrew.....	28
8.6	Adjustment by moving the detent plate .....	29
<b>9</b>	<b>Maintenance and cleaning .....</b>	<b>30</b>
9.1	Cleaning.....	30
9.2	Maintenance .....	31
9.3	Inspection interval and function test .....	31
9.4	Tools .....	32
9.5	Renewing the pressure roll .....	33
9.6	Working inside the housing.....	34
	9.6.1 Renewing drive rolls.....	35
	9.6.2 Renewing the timer .....	38
	9.6.3 Renewing the motor .....	41
9.7	Checks .....	42
<b>10</b>	<b>Malfunctions – causes and rectification.....</b>	<b>43</b>
10.1	Renewing the internal fuse .....	45
<b>11</b>	<b>Spare parts and accessories .....</b>	<b>46</b>
<b>12</b>	<b>Emergency .....</b>	<b>47</b>
<b>13</b>	<b>Dismantling and disposal .....</b>	<b>47</b>
<b>14</b>	<b>Literature .....</b>	<b>47</b>
<b>15</b>	<b>Test log .....</b>	<b>48</b>

## 1 Introduction

### 1.1 Designated use

The FRIABILIMETER is used for determining the friability and whole hyaline of barley malt grains directly after kilning. It mechanically separates a malt sample into hard (glassy) and friable (easily crushed) constituents. The FRIABILIMETER consists of a mechanical abrading device with an electric motor and an electronic timer.

The internationally recognized method is based on the research results of Prof. Lucien Chapon. This method detects differing malt qualities. The brewery can measure the malt quality immediately on delivery and use the information to achieve consistent malt blends.

The friability is determined according to international methods, e.g. EBC<sup>1</sup> method 4.15, MEBAK<sup>2</sup> 4.1.3.6 and ASBC<sup>3</sup> Malt-12. Pfeuffer GmbH has cooperated with the EBC analysis committee to establish a FRIABILIMETER network which determines a binding reference friability value.

The FRIABILIMETER is configured as a portable device with a mains plug.

Private use of the FRIABILIMETER is not allowed.

### NOTICE

The FRIABILIMETER is exclusively intended for the indicated purpose.

Any other use beyond this definition, or conversion of the FRIABILIMETER without written consultation with Pfeuffer GmbH, is regarded as not in accordance with the designated use.

Pfeuffer GmbH will not be liable for any damage resulting from this! The risk is the responsibility of the owner alone.

The FRIABILIMETER is only allowed to be taken into operation if it can be ensured that all safety devices are functioning.

#### The following are prohibited

- **crushing firm, solid objects made of metal, stone, concrete or other foreign bodies!**
- **filling liquid and sticky products!**

Experience to date shows that the FRIABILIMETER is **unsuitable for wheat malts!**

The samples to be used in accordance with the designated use of the FRIABILIMETER are obtained by the owner.

Correct treatment of these materials and the associated risks are exclusively the responsibility of the owner.

The owner must provide information about dangers and disposal.

The designated use also includes complying with the operating instructions as well as the maintenance and servicing conditions as defined in these operating instructions.

These operating instructions do not release the owner from its responsibility to develop and apply, or have applied, health and/or safety regulations appropriate for the requirements of the overall system, and to monitor compliance with the same.

<sup>1</sup> European Brewers' Convention

<sup>2</sup> Central European Brewing Analysis Commission

<sup>3</sup> American Society of Brewing Chemists

**1.2 EC/EU Declaration of Conformity****EC/EU Declaration of Conformity**

In accordance with the EC/EU Directives:

- Machinery 2006/42/EC
- Electromagnetic Compatibility (EMC) 2014/30/EU
- Restriction of the use of certain hazardous substances in electrical and electronic equipment (RoHS) 2011/65/EU

Manufacturer: **PFEUFFER**

**Pfeuffer GmbH**  
Flugplatzstraße 70  
97318 Kitzingen  
GERMANY

Phone: +49 9321 9369-0  
info@pfeuffer.com  
www.pfeuffer.com

The manufacturer has sole responsibility for issuing this Declaration of Conformity.

Person authorized to compile the technical documents:

Lothar Pfeuffer, General Manager

Product: **Friabilimeter** malt friability measuring instrument

Serial number: \_\_\_\_\_

The aforementioned product complies with the requirements of the following harmonized standards:

DIN EN ISO 12100:2010

DIN EN 60204-1:2006

DIN EN 61010-1:2011

DIN EN 61000-6-2:2006

DIN EN 61000-6-3:2007

DIN EN 61326-1:2013

EN IEC 63000:2018

Any modification to the FRIABILIMETER not agreed with us shall result in this declaration becoming null and void.

Kitzingen, \_\_\_\_\_

\_\_\_\_\_  
Lothar Pfeuffer, General Manager

### 1.3 Structural features of the danger notes

The operating instructions from Pfeuffer GmbH contain instructions that you must comply with for your personal safety as well as to avoid damage to property. The instructions for your personal safety are highlighted by a warning triangle. Comply with the following categories of danger notes and explanations of symbols:

Pictogram	SIGNAL WORD
	Type of danger and its source
	Possible consequence of failure to comply
	⇒ Measure to guard against the danger.

#### DANGER

This is a warning about a highly dangerous situation that will lead to serious or fatal injuries.

#### WARNING

This is a warning about a dangerous situation that may result in serious or fatal injuries.











#### CAUTION

This is a warning of a possibly dangerous situation that will lead to slight or moderate injuries.

#### NOTICE

This is a warning about harmful situations for the product and/or environment.

### 1.4 Pictograms in the operating instructions

	Notes of particular importance and/or additional information		Warning
	Comply with the operating instructions		Warning of electrical voltage
	Pull out mains plug		Warning of hand injuries
	Protective earth connection		Recycling marking – Supply refuse for recycling
	Do not reach in		Disposal with the household garbage is forbidden!

### 1.5 Abbreviations in electrical engineering

Color abbreviations for the individual strands (conductors) of a cable according to DIN IEC 60757:

Color	Color abbreviations	Color	Color abbreviations
Black	BK	Violet	VT
Brown	BN	Gray	GY
Red	RD	White	WH
Orange	OG	Pink	PK
Yellow	YE	Turquoise	TQ
Green	GN	Green-yellow	GNYE
Blue	BU		

Conductor designations according to DIN VDE 0293-308:

L	Live conductor, phase (outer conductor)	Color abbreviations
L1	Outer conductor 1	BN
L2	Outer conductor 2	BK
L3	Outer conductor 3	GY
N	Neutral conductor	BU
PE	Protective earth conductor	GNYE

### 1.6 Identification

Sample Pfeuffer GmbH type plate:



The information in these operating instructions applies exclusively to the device with the type designation indicated on the title sheet.

The type plate with the type designation can be found on the side of the machine housing (rear right).

It is important for all questions to specify the correct type designation, serial number and year of manufacture. Only in this way will rapid processing be possible.

## 2 Safety

### NOTICE

**It is strictly prohibited to deactivate the safety devices or modify their mode of effect.**

### 2.1 Built-in safety systems

The built-in safety systems must be checked at regular intervals with the corresponding test methods, see the following table:

Test intervals	Test methods
<b>d</b> = Daily	<b>V</b> = Visual check
<b>w</b> = Weekly	<b>F</b> = Function check
<b>m</b> = Monthly	<b>M</b> = Measurement
<b>¼ y</b> = Every three months	
<b>½ y</b> = Every six months	
<b>y</b> = Yearly	



**Mains disconnecter in a portable device**

Test	
Intervall	Method
y	F

The main switch **ON/OFF** is the mains disconnecter, and also serves as the EMERGENCY OFF function. It is located on the top of the device.

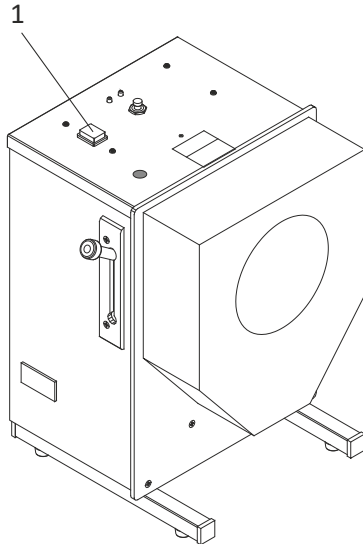

Figure 1: Main switch ON/OFF

Item	Designation
1	Main switch ON/OFF

The connection for the mains cable (power connector IEC 60320 C14) is located at the rear.

**NOTICE**

Detachable mains cables must not be replaced by inadequately dimensioned mains cables. Only the specified mains cables may be used!



- ⇒ In an emergency, switch off the FRIABILIMETER using the main switch, position OFF.
- ⇒ Disconnect the mains cable from the electrical power supply, or pull out the power coupling (IEC 60320 C13).
- ⇒ Secure the mains cable appropriately against unauthorized reconnection by placing it where it can be monitored continuously.
- ⇒ Ensure that the mains cable is never a tripping hazard or that someone can become caught or step on it.



Electrical connections, see **chapter 2.2**.



Arrange the plug/socket combination at the place of installation so that it can be observed clearly and reached quickly in an emergency.

**Protective covers**

Test	
Interval	Method
<b>m</b>	<b>V</b>

The FRIABILIMETER is protected during operation by its complete housing and the front hood to prevent reaching into the machine.



**CAUTION**

**Danger of crushing! Finger injuries!**

- ⇒ During operation, do not place your fingers
  - into the filling funnel.
  - into the working area of the sieve drum from below.

**NOTICE**

To avoid damage:

- ⇒ Make sure that no objects are lying on the device which could drop into the filling funnel!
- ⇒ Do not insert any long, pointed objects into the filling funnel or into the working area of the sieve drum from below!

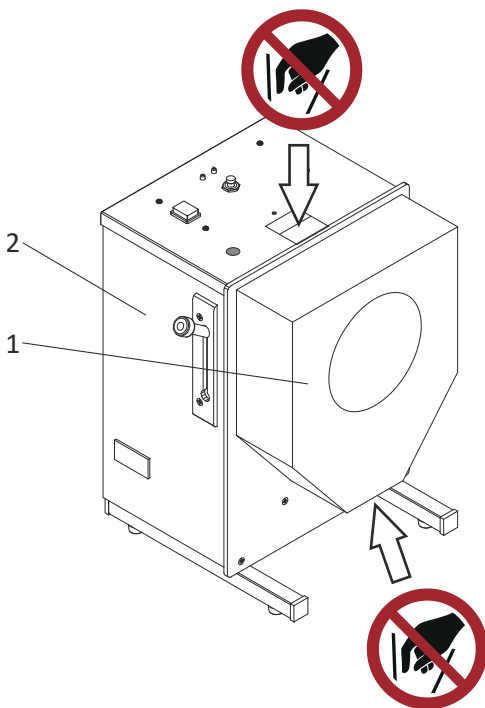

Item	Designation
1	Front hood
2	Housing, complete

Figure 2: Protective covers

Test	
Interval	Method
<b>m</b>	<b>V</b>

In the front hood, there is a blue magnet (see Figure 3) which interacts with the reed switch inside the housing.

**NOTICE**

The FRIABILIMETER cannot be taken into operation without the front hood!  
 The motor will stop immediately if the front hood is removed during operation!  
 If the LED "Operation" lights up red, the front hood has not been put on, or not put on correctly.

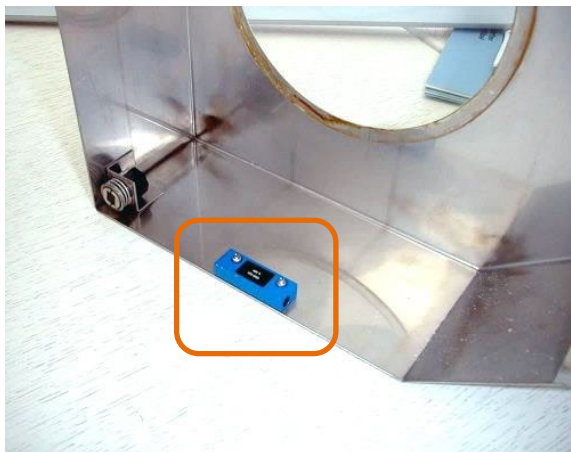

Figure 3: Safety device (blue magnet) for front hood

## 2.2 Electrical connections

The FRIABILIMETER must only be operated with the specified voltages. The fuse must always be replaced with identically specified values, see **chapter 3** and the specifications on the type plate.



The device is in protection class I, and may only be connected to a socket which has been grounded in accordance with regulations with a ground wire. The instrument may only be operated on a power supply that is protected by an RCCB (**R**esidual **C**urrent operated **C**ircuit **B**reaker).

## 2.3 Operating and danger areas on the FRIABILIMETER

### Operating area

Make sure the installation height is sufficient (according to the stature of the operating personnel). A suitable base (e.g. table) is required for this.

### Danger area

The entire area one meter around the FRIABILIMETER is a danger area during maintenance and repair work. Keep the area around the FRIABILIMETER clear of objects.

## 2.4 Operating and maintenance personnel

Operating and maintenance personnel are people who are responsible for transport, installation, setup, operation and cleaning of the FRIABILIMETER, and for eliminating malfunctions.

1. The FRIABILIMETER is only allowed to be operated by authorized and instructed people.
2. The responsibilities for operating the FRIABILIMETER must be clearly defined and complied with so that no unclear competencies arise with regard to the aspect of safety.
3. The switch-off procedures specified in the operating instructions must be complied with during all work (operation, maintenance, repair, etc.), see **chapter 2.9**.
4. The operator must refrain from any working method that impairs safety on the FRIABILIMETER.
5. The operator must ensure that only authorized people work on the FRIABILIMETER.
6. The owner is obliged to report immediately to the owner any changes that take place on the FRIABILIMETER which impair safety.
7. The operating personnel must be provided by the owner with appropriate protective equipment in accordance with legal requirements and the material to be processed.
8. The owner must issue regular instructions regarding the use of personal protective equipment, and must check such equipment is being used.

## 2.5 Safety measures (to be carried out by the owner)

It should be noted that the owner is responsible for the following aspects with regard to the operating and maintenance personnel

- ⇒ Providing instruction in the protective devices for the FRIABILIMETER
- ⇒ Monitoring compliance with the safety measures.

The frequency of the function tests described in **chapter 9.3** must be complied with.

The work described in these operating instructions is configured in such a way that

- ⇒ it is explained in the chapters Function and Operation for the operating personnel
- ⇒ it is explained in the chapters Delivery, Transport and storage, Installation and commissioning, Maintenance and cleaning, Malfunctions – causes and rectification and Dismantling and disposal for a **specialist operator**.

The chapters Delivery, Transport and storage, Installation and commissioning, Maintenance and cleaning, Malfunctions – causes and rectification and Dismantling and disposal are only intended for **specialist operators**. Work described in this chapter is only to be carried out by **specialist operators**.

### Instructed person

A person who has been instructed and, if necessary, trained by a **specialist operator** regarding the tasks assigned to him/her and the possible dangers in the event of incorrect conduct, and who has also been instructed regarding the necessary protective devices and protective measures.

### Specialist operator

An individual who, due to his/her relevant specialist training and/or experience, is capable of recognizing risks and avoiding dangers that may occur during use of the product.

(Definition according to DIN EN 82079-1:2013-06)

### Qualified electrician

Person who is in a position to carry out work on electrical systems and independently recognize potential dangers on the basis of their technical training, knowledge and experience and knowledge of the relevant standards and provisions. Qualified electricians are specially trained for the working environment in which they work and have knowledge of the relevant standards and provisions.

### Obligations on the owner



In the European Economic Area (EEA), national implementation of the framework directive 89/391/EEC and corresponding individual directives, in particular the directive 2009/104/EC concerning the minimum health and safety requirements for the use of work equipment by workers at work, as amended, are to be observed and adhered to.

In addition, he/she must comply with the local legal requirements on:

- ⇒ Safety of personnel (accident prevention regulations)
- ⇒ Accident prevention regulation DGUV<sup>4</sup> Regulation 3 (previously BGV A 3) "Electrical systems and equipment"
- ⇒ Safety of work equipment (protective equipment and maintenance)
- ⇒ The permissible noise load, depending on the location and the time of day (in Germany, TRLV<sup>5</sup> apply)
- ⇒ Product and material disposal (waste legislation)
- ⇒ Cleaning (cleaning agents and disposal)
- ⇒ Hazardous substances (in Germany, TRGS<sup>6</sup> 555 apply)
- ⇒ Environmental protection regulations.

<sup>4</sup> DGUV = Association of German statutory insurance

<sup>5</sup> TRLV = Technical rule for the noise and vibration occupational health and safety ordinance

<sup>6</sup> TRGS = Technical rule for hazardous substances

## 2.6 General safety notes



The safety equipment and safety notes described in these operating instructions must be complied with.



1. Disconnect the FRIABILIMETER from the electrical power supply if there are malfunctions.
2. Disconnect the FRIABILIMETER from the electrical power supply before cleaning work.
3. Do not allow the FRIABILIMETER to get wet during transport, storage, cleaning and operation.
4. Make sure that the FRIABILIMETER is only operated when in correct working order.
5. Never touch the mains cable with moist hands.
6. Only use genuine spare parts and accessories.

## 2.7 Safety tests

Pfeuffer GmbH carried out the following safety tests at the factory:

Testing and checking according to DIN EN 60204-1:

- Check that the electrical equipment is in compliance with the technical documentation.
- Continuous connection of the protective earth system
- Insulation resistance tests
- Voltage tests
- Protection against residual voltages
- Function tests

The functions of the electrical equipment, in particular those relating to safety and protective measures, have been tested.

## 2.8 Residual dangers in connection with the FRIABILIMETER

⇒ During all work on electrically operated components, pay attention to dangers from electrical current.

## 2.9 Switch-off procedure

**DANGER**



**Touching live parts can be fatal!**

It is essential to comply with the following switch-off procedure prior to cleaning, maintenance or repair work (only by specialist personnel):

⇒ Empty the FRIABILIMETER.

⇒ Switch off the FRIABILIMETER at the main switch position **OFF**.



⇒ Disconnect the mains cable from the electrical power supply, or pull out the IEC 60320 C13 power coupling.

⇒ The mains cable must be able to be kept under the direct supervision of the person in the danger area.

⇒ During cleaning, make sure that no water, steam or dust can penetrate the electronics area.

**3 Technical data**

FRIABILIMETER	Malt friability measuring instrument
Sample amount	50 ±0.01 g
Product	Barley malt
Measuring time	Timer 8 minutes

**3.1 Dimensions and weight**

Height	400 mm
Width	300 mm
Length	270 mm
Weight	12 kg

**3.2 Power supply**

Operating voltage/frequency	230 V ~ 50 Hz
Power consumption	70 VA
Number of phases	1-ph / PE
Protective earth conductor	PE (yellow/green) in the mains cable
Internal fuse	315 mA slow-blow glass microfuse 5x20 mm
Mains cable	With removable supply cable (power connector cable IEC 60320 C13/C14); 10 A, 250 V
Installation regulations	Configured according to VDE <sup>7</sup> – Protection class I / protective earth

**3.3 General data**

Ambient temperature storage and transport	-10 °C to +60 °C
Ambient temperature measurement	+15 °C to +40 °C
Atmospheric humidity	20 % - 80 % non-condensing
Installation condition	Level table surface without vibration

<sup>7</sup> VDE = Association for Electrical, Electronic & Information Technologies (Germany)

## 4 Delivery, transport and storage



The Delivery, transport and storage chapter is only intended for **specialist operators**.

### 4.1 Scope of delivery

The standard scope of delivery to the owner comprises: FRIABILIMETER malt friability measuring instrument including sieve drum and front hood, mains cable with removable connection (IEC 60320 C13/C14 power connector cable), measuring caliper, can of Pfeuffer test malt 400 g, flat-blade screwdrivers 3x40 mm and 2x40 mm, plastic funnel, collecting vessel, small and large cleaning brushes and operating instructions.

### 4.2 Transport and packaging

Systems, machines and devices from Pfeuffer GmbH are carefully tested and packaged prior to dispatch, however it is not possible to exclude the risk of damage during transport.

#### Incoming check

Check for completeness with reference to the delivery note.

#### In case of damage

Check the delivery for damage (visual inspection).

#### In case of complaints

If the delivery suffered damage in transit:

- ⇒ Keep the packaging (to allow it to be checked subsequently by the forwarding company, or for sending back).
- ⇒ Immediately inform the supplier or Pfeuffer GmbH.

### 4.3 Intermediate storage

The freight packaging of the FRIABILIMETER and the accessory/replacement parts is configured for a storage duration of up to six months from delivery.

- ⇒ Do not place any heavy objects on the packaging.

#### Storage conditions

Enclosed, dry room with a room temperature between min. -10 °C and max. +60 °C.

### 4.4 Unpacking and packing

- ⇒ Open the packaging to avoid damage to the housing and other components.



- ⇒ Remove the sieve drum, the operating instructions and the remainder of the accessories as stated on the delivery note.

Figure 4: Unpacking I

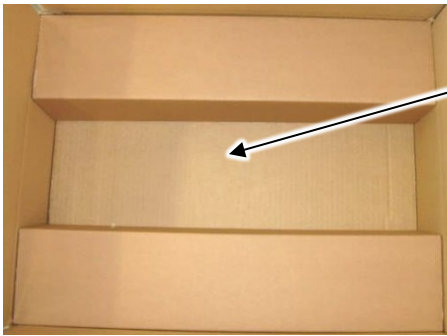

⇒ Remove the cardboard box.

Figure 5: Unpacking II

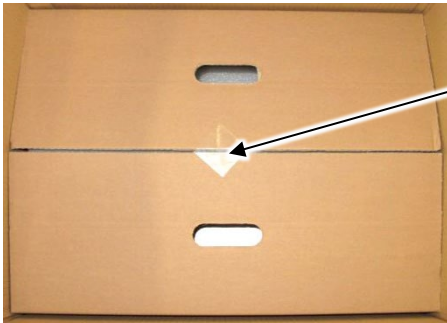

⇒ Open the cardboard box inside.

Figure 6: Unpacking III

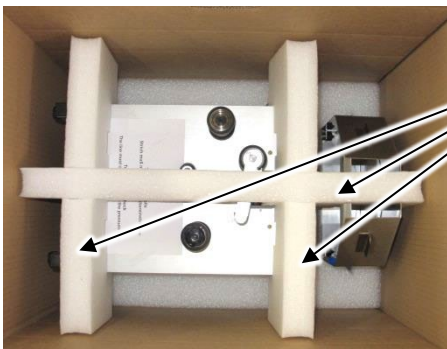

⇒ Remove the PE foam padding.

Figure 7: Unpacking IV



- ⇒ Remove the front hood and the FRIABILIMETER.
- ⇒ Do not lift out the FRIABILIMETER by its drive and pressure roll.
- ⇒ Note that the weight is approx. 12 kg.

Figure 8: Unpacking V

- ⇒ Move the FRIABILIMETER to the installation location, paying attention to the setup instructions in **chapter 5**.
- ⇒ Keep the original packaging.

**Packaging for return delivery**

- ⇒ If possible, use the original packaging and the original packaging material. If neither is available any longer, request new packaging from Pfeuffer GmbH.



**WARNING****Risk of suffocation**

Packaging materials (e.g. film, polystyrene, cardboard boxes) can be dangerous to children.



- ⇒ Keep packaging material away from children.
- ⇒ Do not leave packaging material lying around carelessly.
- ⇒ Dispose of packaging material in an environmentally friendly way.

**5 Installation and commissioning**

The Installation and commissioning chapter is only intended for **specialist operators**.

**Installation**

- ⇒ Carefully unpack the FRIABILIMETER (see **chapter 4.4**).
- ⇒ Place the FRIABILIMETER horizontally on a solid table with a smooth, clean surface.
- ⇒ Make sure there is an adequate distance to all sides so that no heat buildup can occur.
- ⇒ Do not set up the FRIABILIMETER close to apparatus/devices that are sensitive to dust.
- ⇒ Avoid exposure to direct sunlight and extreme ambient conditions.
- ⇒ Make sure that the installation height is ergonomic according to the stature of the operating personnel.
- ⇒ Connect the supplied mains cable to the FRIABILIMETER using the connector (power connector cable IEC 60320 C13/C14).



- ⇒ Connect the plug of the mains cable to a suitably earthed socket with protective earth conductor.

- ⇒ Take the FRIABILIMETER into operation according to the instructions in **chapter 7**.

## 6 Function

### 6.1 Overview



Figure 9: Overview

Item	Designation	Item	Designation
1	Main switch ON/OFF	8	Pull handle
2	Setscrew	9	Pressure roll
3	Start key	10	Drive rolls
4	Sticker: Timer 8 minutes	11	Sieve drum
5	Filler opening	12	Cleaning brush
6	Front hood	13	Collecting tray
7	Operating hours counter		

### 6.2 Sequence of functions

The FRIABILIMETER is a friability measuring instrument for barley malt. The friability is measured using a mechanical abrasion process.

Weigh out a cleaned sample of 50 g on a balance with 0.01 g accuracy, and fill the sample. Pull the pull handle and engage it in the bottom position. Press the start key. The pressure roll presses the grains of barley malt against the rotating sieve drum with a constant spring pressure. The friable constituents fall through the wire mesh. Glassy grains and hard fragments remain in the sieve drum. The FRIABILIMETER switches off automatically after eight minutes. The remaining constituents in the sieve drum are weighed back and this information is used for calculating the friability value out of one hundred.

For precise information about operation, refer to **chapter 7**.

**7 Operation**



The FRIABILIMETER is only allowed to be operated by personnel who have been qualified and trained in its operation.

**7.1 Control elements**

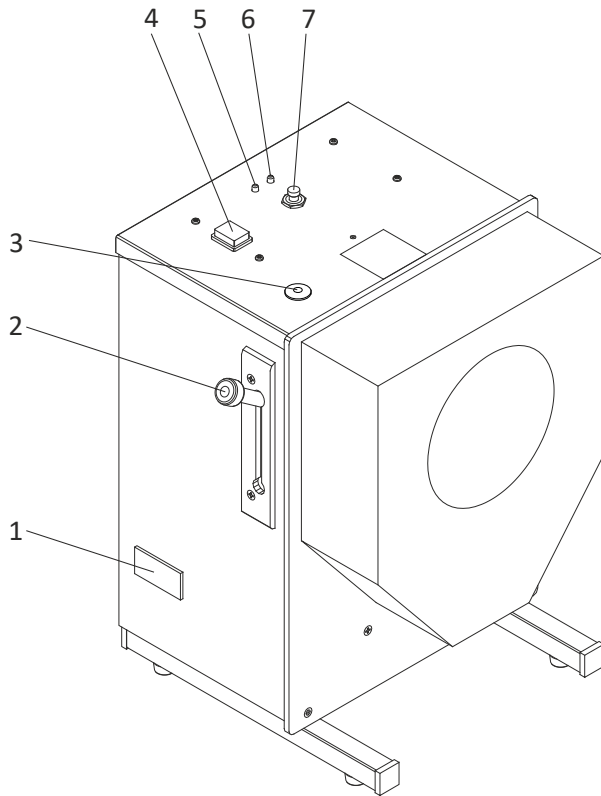

Item	Designation
1	Operating hours counter
2	Pull handle
3	Setscrew
4	Main switch ON/OFF
5	"Operation" LED
6	"On" LED
7	Start key

Figure 10: FRIABILIMETER control elements

**7.1.1 Main switch ON/OFF**

The main switch **ON/OFF** switches the FRIABILIMETER on and off. After switching on, the "On" LED lights up green.

**7.1.2 Pull handle**

The pull handle applies pressure to the pressure roll, or removes the pressure.

**7.1.3 Setscrew**

The setscrew is required for precise adjustment of the FRIABILIMETER, see **chapter 8.5**.

**7.1.4 Start key**

The start key starts the investigation. The green "On" LED goes out and the "Operation" LED flashes green. The FRIABILIMETER switches off automatically after eight minutes have elapsed. If the LED "Operation" lights up red, the front hood has not been put on, or not put on correctly.

**7.1.5 Operating hours counter**

The FRIABILIMETER is equipped as standard with an operating hours counter to provide a clear overview of the necessary maintenance work. Devices of an older design can be retrofitted by Pfeuffer GmbH.

Investigations at the Pfeuffer GmbH factory have shown that the FRIABILIMETER must be checked depending on the malt quality being investigated.

⇒ To do this, carry out an investigation with the test malt and make a note of the counter reading after each check (see master copy on last page).

## 7.2 Preparations



Pfeuffer GmbH recommends a "warm-up" of the device after a longer standstill (from 4 hours) or after switching on:

⇒ Perform two investigations and discard the results.

### NOTICE

Experience to date shows that the FRIABILIMETER is **unsuitable for wheat malts!**

Select a **representative barley malt sample** for the measurement.

**Foreign bodies** must be **removed** prior to the investigation!

Allow the samples to acclimatize to room temperature!

It is necessary to have a **sample quantity** of **50 ±0.01 g** to achieve an accurate result.

The moisture content of the sample should be between 3.5 and 5%. Other values will influence the result.

A high husk content or husks which have absorbed water can lead to deviations in the results.

Malts from particular winter barleys can lead to different results because of their high proportion of husk (Analytica-EBC).

The less homogeneous the malts, the greater the divergence in results.

Malt samples must be stored in an air-tight container with little or no air inclusion. Fill and seal the container immediately after taking out the sample.

It is necessary to calibrate the FRIABILIMETER in relation to a standard malt with a known friability. If the friability result differs from the accepted value by more than  $r_{95}$  (of an internal test malt) or more than  $R_{95}$  (of an external test malt), the FRIABILIMETER will have to be calibrated and checked regularly, see **chapter 8**.

### CAUTION



#### Dust warning

Due to the nature of the samples, visible cereal dust will be released into the surroundings during operation.

⇒ Check whether inhaling large quantities might lead to irritation or illnesses of the respiratory passages, and if so then take appropriate measures.

### 7.3 Weighing out the sample



Figure 11: Weighing out the sample

- ⇒ Take a representative sample.
- ⇒ Mix it well.
- ⇒ Divide up the sample in a sample divider (e. g. Pfeuffer riffle sample divider EBC).
- ⇒ Weigh out **50 ±0.01 g** of malt.

### 7.4 Filling the sample



Figure 12: Filling the sample

- ⇒ Insert the sieve drum and put on the front hood.
- ⇒ Place the collecting tray under the opening of the front hood.
- ⇒ Insert the plastic funnel into the filler opening on the top.
- ⇒ Fill the sample.

## NOTICE

The FRIABILIMETER has a safety circuit. The devices switches off immediately when the front hood is removed!

The investigation result will be falsified if the correct running time (8 minutes) is not respected. Repeat the investigation in this case!

### 7.5 Switching on the FRIABILIMETER



Pfeuffer GmbH recommends a "warm-up" of the device after a longer standstill (from 4 hours) or after switching on:

- ⇒ Perform two investigations and discard the results.

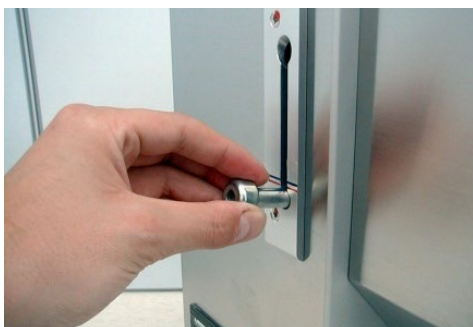

Figure 13: Engaging the pull handle at the bottom

- ⇒ Switch on the FRIABILIMETER at the main switch position ON.  
The "On" LED lights up.
- ⇒ Pull out the pull handle.
- ⇒ Engage the pull handle in the bottom position.  
This presses the pressure roll against the sieve drum.



Figure 14: Pressing the start key

⇒ Press the start key.

The green "On" LED goes out and the "Operation" LED flashes green.

The FRIABILIMETER switches off automatically after eight minutes.



If the LED "Operation" lights up red, the front hood has not been put on, or not put on correctly.



### CAUTION

#### Danger of crushing! Finger injuries!



⇒ During operation, do not place your fingers

- into the filling funnel.
- into the working area of the sieve drum from below.

### NOTICE

To avoid damage:

- ⇒ Make sure that no objects are lying on the device which could drop into the filling funnel!
- ⇒ Do not insert any long, pointed objects into the filling funnel or into the working area of the sieve drum from below!



Figure 15: Engaging the pull handle at the top

⇒ Pull out the pull handle.

⇒ Engage the pull handle in the top position.  
The pressure roll is depressurized.

**7.6 Emptying the sample**



Figure 16: Removing the front cover

- ⇒ Remove the collecting tray.
- ⇒ Hold the front hood using the two grips at the bottom.
- ⇒ Lift off the front hood forward.
- ⇒ Brush the dust off and remove all the material outside the sieve drum.
- ⇒ Place a sheet of white paper under the sieve drum to collect any particles that may fall out.



Figure 17: Removing the sieve drum

- ⇒ Use the thumb of your left hand to press in the brass roller.
- ⇒ Lift up the sieve drum with your right hand.
- ⇒ Pull off the sieve drum forward.



Figure 18:  
Emptying the content of the sieve drum

- ⇒ Empty the content onto the paper or into a separate tray.
- ⇒ This mass is referred to as **A**.
- ⇒ Mass **A** is used for determining the whole hyaline and the part hyaline.



Figure 19:  
Putting the sieve drum down flat

**NOTICE**

---

The sieve drum can be damaged if it rolls off the work surface.

- ⇒ Always put down the sieve drum flat.

---

## 7.7 Evaluation

### Determination of hyaline

The hard malt components are distinguished between part hyaline and whole hyaline. Increasing components of whole hyaline grains reduce the brewing value.

All grains which are larger than  $\frac{3}{4}$  of a grain are sorted from the glassy malt constituents manually. This fraction referred back to 100% is considered as whole hyaline.

Shake the contents of the sieve drum onto a sorting sieve of 2.2 mm slit width for 60 seconds. The fraction left on the sieve is considered as part hyaline.

### Meaning of hyaline

Excessive hyaline has an adverse effect on the mashing and lautering process. During the brewing process problems will arise during the wort clarification, fermentation, maturing and filtration.

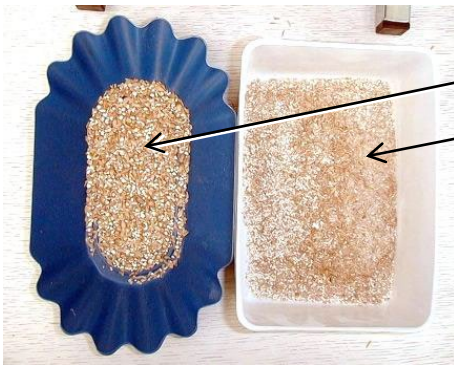

Two fractions are available following the investigation:

- Content of the sieve drum, glassy constituents (mass **A**)
- Content of the collecting tray, friable constituents

The friable constituents are not relevant for the further investigation and can be disposed of.

Figure 20: Fractions following the investigation

#### 7.7.1 Friability M

⇒ Weigh the mass **A** to an accuracy of two decimal places.

Calculation formula:  $M = 100 - (2 \times A)$

Sample calculation:

Mass A = 8.32 g                       $M = 100 - (2 \times 8.32 \text{ g})$                        $M = 83 \%$

M = Friability in percent (%) - rounded to the nearest whole number

A = Mass of the fraction remaining in the sieve drum (glassy constituents) in grams.

#### 7.7.2 Whole hyaline (whole grains) WH

⇒ Manually separate out the whole grains from the mass **A** = mass **B**.



Whole grains are also grains which are larger than  $\frac{3}{4}$  of a grain.

⇒ Weigh the mass **B** to an accuracy of two decimal places.

Calculation formula:  $WH = 2 \times B$

Sample calculation:

Mass B = 0.76 g                       $WH = 2 \times 0.76 \text{ g}$                        $WH = 1.5 \%$

WH = Whole hyaline in percent (%) - stated to one decimal place

B = Mass of the manually separated out whole grains in grams.



**7.7.3 Part hyaline (partially non-comminuted grains) PH**



- ⇒ Place the remaining fraction (mass **A**) and the whole grains (mass **B**) onto a 2.2 mm sorting sieve (e. g. SORTIMAT or hand-held sieve).
- ⇒ Shake the fraction for about 60 seconds = mass **C**.
- ⇒ Weigh the mass **C** to an accuracy of two decimal places.



Figure 21:  
Mass A and mass B

Figure 22:  
Mass C on hand-held sieve

Calculation formula: **PH = 2 x C**

Sample calculation:

Mass C = 2.38 g                      PH = 2 x 2.38 g                      PH = 4.8 %

PH = Part hyaline in percent (%) - stated to one decimal place  
C = Mass of the fraction remaining on the sorting sieve in grams.

Standard values<sup>8</sup>:

Friability (bright malt) <b>M</b>		Whole hyaline <b>WH</b>	
More than 81 %	Very good	Less than 1 %	Very good
78 to 81 %	Good	1 to 2 %	Good
75 to 78 %	Satisfactory	2 to 3 %	Satisfactory
Less than 75 %	Unsatisfactory	More than 3 %	Unsatisfactory



Pfeuffer GmbH recommends carrying out **three investigations** on **each sample** and calculating the **average value**.

**7.8 Switching off the FRIABILIMETER**

- ⇒ Switch off the device at the main switch position **OFF**.
- ⇒ Clean the FRIABILIMETER and the sieve drum after each investigation, see **chapter 9**.
- ⇒ Reinsert the sieve drum and put on the front hood.
- ⇒ Engage the pull handle in the top position (inactive position).

<sup>8</sup> Information from "Technologie für Brauer & Mälzer" (Technology for Brewers and Maltsters), 9th edition 2007

## 8 Checking the device settings



The Checking the device settings chapter is only intended for **specialists**.

To ensure an accurate investigation, it is essential for the device settings of the FRIABILIMETER to be checked at regular intervals.

The FRIABILIMETER is equipped with an operating hours counter as standard. Older devices can be retrofitted by Pfeuffer GmbH.



The **device setting** procedure must be carried out every **120 operating hours**.

⇒ Use the master copy of the test log on the last page for this purpose.

⇒ Always make a note of the precise counter reading.



Inhomogeneity of the malt means it will be necessary to carry out 2-3 investigations of each sample and take the average value.

⇒ Use a good quality homogeneous test malt (EBC test malt/Pfeuffer test malt) (approx. 80 % friability).

⇒ Always store the test malt so the original moisture (3.5 to 5 %) is retained.

⇒ If the friability results do not match, check the following points:



Before each check of the device settings, first carry out an investigation and dispose of this sample afterwards without logging the values.

### 8.1 Timer runtime

⇒ Check the runtime of the preset timer (8 minutes  $\pm$ 5 seconds) using a stopwatch.

⇒ Contact Pfeuffer GmbH if there is a discrepancy.

### 8.2 Abrasion on the pressure roll

#### NOTICE

The pressure roll must be able to rotate freely without scraping!



Figure 23: Checking the pressure roll diameter

⇒ Take off the front hood and the sieve drum.

⇒ Check the diameter measurement using a measuring caliper (new =  $\varnothing$  40 mm).

⇒ You can continue to use the pressure roll if there is only a slight amount of abrasion (about  $\varnothing$  39.5 mm). Use the setscrew to compensate for the abrasion, see **chapter 8.5**.

⇒ Renew the pressure roll if the diameter is less than  $\varnothing$  39.0 mm, see **chapter 9.5**.

⇒ Make a note of the calibration or renewal in a test log (see master copy on last page).

### 8.3 Abrasion on the drive rolls

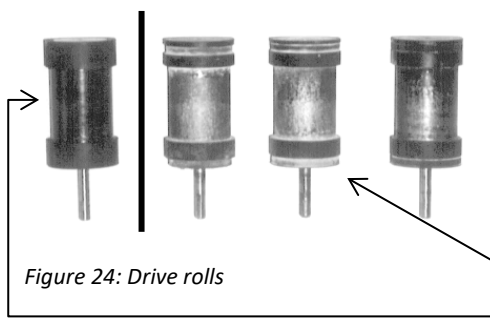

Figure 24: Drive rolls

- ⇒ Take off the front hood and the sieve drum.
- ⇒ Regularly look and check the drive rolls.
- ⇒ If you observe an indentation on the running surface of the rubber covering, check the diameter dimension using a measuring caliper.

Worn drive rolls

New drive roll

- ⇒ You can continue to use the drive roll if there is only a slight amount of abrasion (about  $\varnothing$  39.5 mm). Compensate for the abrasion by using the setscrew (see **chapter 8.5**) or by moving the detent plate (see **chapter 8.6**).
- ⇒ If the diameter is less than  $\varnothing$  39.0 mm, have the drive roll renewed by a specialist or by Pfeuffer GmbH's customer service (see **chapter 9.6** and **9.6.1**).
- ⇒ Make a note of the renewal, the calibration and the subsequent check with test malt in a test log (see master copy on last page).

### 8.4 Sieve drum



Figure 25: Damaged sieve drum

- ⇒ Regularly look and check the sieve drum. There should not be any tears in the wire mesh or any cracks in the weld.
- ⇒ Renew the sieve drum if it is damaged. For spare parts, see **chapter 11**.

- ⇒ The sieve drums are subject to production tolerances, as a result of which it will be necessary to check the setting of the device with test malt after a renewal, and to make any necessary calibration, see **chapters 8.5** and **8.6**.
- ⇒ Make a note of the renewal, the calibration and the subsequent check with test malt in a test log (see master copy on last page).

#### NOTICE

Repairing the sieve drum is not recommended:

Solder spots or soldered-on metal plates will alter the sieve surface. This will change the abrasion process and falsify the investigation result.

It is not possible to compensate for a damaged/repared sieve drum using the device settings.



To prevent contact between the sieve drum and the front plate, they are help about 0.3 to 0.5 mm apart using three sliding pins.

This gap must be checked regularly so that the sieve drum can rotate freely, see also **chapter 9.6.1**.

## 8.5 Precise adjustment using the setscrew



Before you make a precise adjustment, carry out and make a note of an investigation with a test malt (see master copy on last page).



⇒ Disconnect the mains cable from the electrical power supply, or pull out the coupler.

There is a plastic cap on the top of the FRIABILIMETER. Under this plastic cap, there is a setscrew inside the housing.

This setscrew directly acts on the spring travel and thus on the force exerted on the sieve drum by the pressure roll.

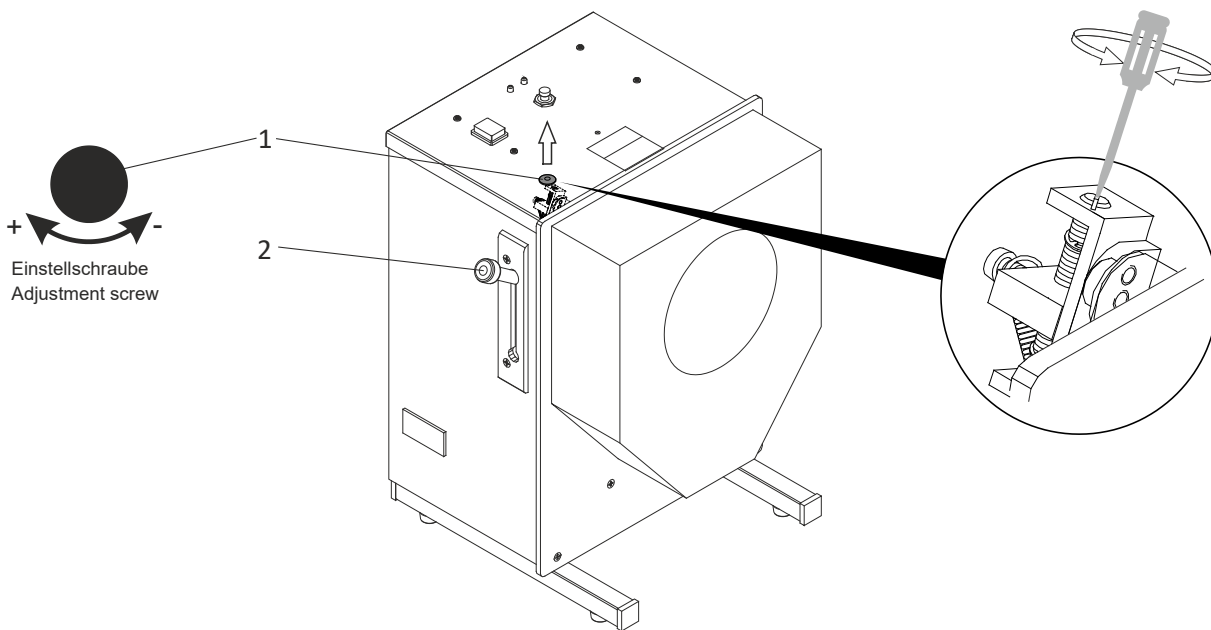

Figure 26: Setscrew

Item	Designation
1	Plastic cap → setscrew
2	Pull handle

- ⇒ Remove the plastic cap.
- ⇒ Engage the pull handle in the top position.
- ⇒ Adjust the setscrew using a flat-blade screwdriver.
- ⇒ Turn the setscrew **clockwise (+) to increase the result.**
- ⇒ Turn the setscrew **counterclockwise (-) to reduce the result.**
- ⇒ Make a note of the precise setting and the subsequent check with test malt in a test log (see master copy on last page).



One rotation corresponds to about 0.1 to 0.2 %.

At a lower friability, the effect on the investigation result is generally greater than at a higher friability.

**8.6 Adjustment by moving the detent plate**



Before you move the detent plate, carry out and make a note of an investigation with a test malt (see master copy on last page).



⇒ Disconnect the mains cable from the electrical power supply, or pull out the coupler.

Another adjustment possibility is the detent plate attached to the housing on the left.

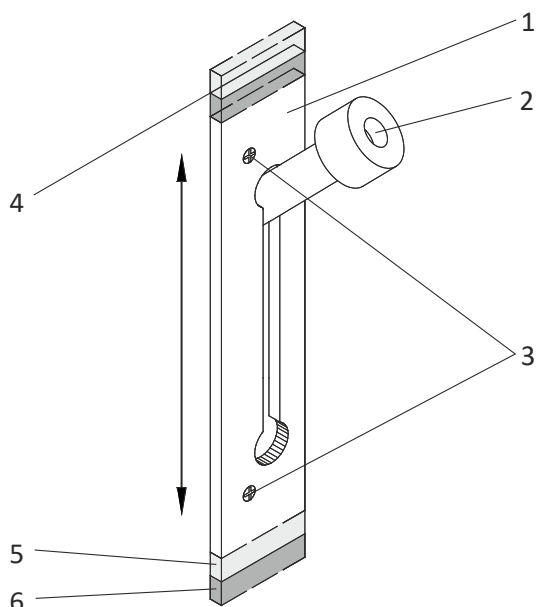

Figure 27: Moving the detent plate

Item	Designation
1	Detent plate
2	Pull handle
3	Countersinking screw M4
4	Mark the initial setting!
5	Moving the detent plate upward = lower friability
6	Moving the detent plate downward = higher friability

⇒ Use an indelible pen to mark the initial setting of the detent plate.

⇒ Unscrew both countersinking screws.

⇒ Move the detent plate.



A 3 mm movement corresponds to about 1.5 % friability

Moving upward = lower friability

Moving downward = higher friability

⇒ Then tighten the two countersinking screws firmly again.

⇒ Make a note of the movement of the detent plate and the subsequent check with test malt in a test log (see master copy on last page).

**9 Maintenance and cleaning**



The "Maintenance and cleaning" chapter is only intended for **specialist operators**.

**NOTICE**

Opening the housing and inappropriate operation will invalidate the warranty.

To ensure trouble-free operation, it is essential for the FRIABILIMETER to be cleaned and maintained at regular intervals.



**DANGER**

**Touching live parts can be fatal!**



It is essential to comply with the switch-off procedure before cleaning, maintenance or repair work! (See **chapter 2.9**)

- ⇒ During all work that is required, wear personal protective equipment according to the company health and safety regulations.
- ⇒ Pay attention to local statutory accident prevention regulations!



The times for carrying out cleaning and maintenance work are based on one-shift working (8 hour/day, 22 days/month, 12 months/year).

- d** = daily
- w** = weekly
- m** = monthly
- ar** = as required
- $\frac{1}{4} \mathbf{y}$  = every three months
- $\frac{1}{2} \mathbf{y}$  = every six months
- y** = yearly

**NOTICE**

The operating company must provide hazard and disposal information.

**NOTICE**

Following cleaning, maintenance or exchanging wearing parts, check that all safety devices are functioning correctly.

**9.1 Cleaning**

**NOTICE**

Do not use any sharp objects or tools for cleaning. Only use objects that are expressly intended for this purpose.

During cleaning, make sure that no water, steam or dust can penetrate the electronics area.

Cleaning	Rectification	Interval
Housing surface	With a clean, dry and lint-free cloth. Clean with a damp cloth in case of heavy contamination.	<b>w</b>

Cleaning	Rectification	Interval
Sieve drum	Use the small or large brush supplied with the product.	<b>After each investigation</b>
Pressure roll	Use the small or large brush supplied with the product.	<b>After each investigation</b>
Drive rolls	Use the small or large brush supplied with the product.	<b>After each investigation</b>



Pfeuffer GmbH recommends a complete cleaning or covering of the device before a longer standstill, in order to preserve the operational readiness of the FRIABILIMETER.

## 9.2 Maintenance

Maintenance is a part of servicing and refers to the scheduled cleaning, checking and replacement of wearing parts. The aim of maintenance is to maintain the full functionality of the device over its lifetime.

The FRIABILIMETER should therefore be checked for wear and tear at regular intervals. The inspection intervals depend on the frequency of use and the ambient conditions to which the FRIABILIMETER is exposed. Only through regular checks (visual inspection) can damage to the device caused during use be detected early and reliably.

If you are unsure whether your device is still completely ready for use, Pfeuffer GmbH's professional service team will be pleased to assist you.

## 9.3 Inspection interval and function test

Sub-assembly	Interval in one-shift working				
	w	m	¼ y	½ y	y
Normal function tests:					
Main switch <b>ON/OFF</b>		<b>X</b>			
Firm seating of magnet (blue) inside the front hood					<b>X</b>
Mains cable and connection					<b>X</b>
Labels and warning notes in place and legible (by visual inspection)					<b>X</b>
Check the correctness and firm fit of the entire machine			<b>X</b>		
Check all cables for damage and aging				<b>X</b>	
Check protective covers for defects, as well as for correct and tight fit		<b>X</b>			
Check all plug-in, screw-in and clamp connections for firm fit, tighten if necessary			<b>X</b>		
Electrical test according to VDE <sup>9</sup>	See DGUV <sup>10</sup> regulation 3				

<sup>9</sup> VDE = Association for Electrical, Electronic & Information Technologies (Germany)

<sup>10</sup> DGUV = Association of German statutory insurance

**DANGER****Damaged cables increase the risk of getting an electric shock!**

- ⇒ Never touch a damaged cable (e.g. cable that has been cut into, insulation damaged etc.)
- ⇒ Disconnect the cable from the electrical power supply immediately.
- ⇒ Replace the cable with a new one.

**NOTICE**

Detachable mains cables must not be replaced by inadequately dimensioned mains cables. Only the specified mains cables may be used!

**9.4 Tools**

Before you start work, prepare the following tools and equipment:

- Drill with 3.3 mm drill bit for drilling out the rivets on the top of the housing
- Phillips screwdriver
- 2 flat-blade screwdrivers (supplied with the product) for renewing the pressure roll and adjusting the setscrew
- 1-2 mm flat-blade screwdriver for sliding pins
- 10 mm hexagon wrench for sliding pins
- 2 mm Allen key for chain sprockets and 4 mm Allen key for pull handle



**9.5 Renewing the pressure roll**



It is only necessary to renew the pressure roll if the diameter is less than 39.0 mm. Check, see **chapter 8.2**.



⇒ Disconnect the mains cable from the electrical power supply, or pull out the coupler.



Figure 28: Unscrewing the pressure roll grub screw

- ⇒ Take off the front hood and the sieve drum.
- ⇒ Only unscrew the bottom grub screw on the holder with a small flat-blade screwdriver.



Figure 29: Pulling out the pressure roll

- ⇒ Pull out the worn pressure roll.



Figure 30: Place spacer rings onto the axle

- ⇒ Use the two spacer rings from the old axle with the new pressure roll.
- ⇒ Insert the new pressure roll into the holder.
- ⇒ Attach the new pressure roll to the holder using the small grub screw at the bottom.
- ⇒ Insert the sieve drum and put on the front hood.

- ⇒ After renewal of the pressure roll, check the device setting with test malt. It may be necessary to adjust the settings, see **chapters 8.5 and 8.6**.
- ⇒ Make a note of the renewal, the calibration and the subsequent check with test malt in a test log (see master copy on last page).

## 9.6 Working inside the housing

### NOTICE

The warranty offered by Pfeuffer GmbH will be invalidated if the housing is opened.

**Pfeuffer GmbH expressly points out that fitting spare parts and renewing wearing parts are procedures which require a certain level of experience!** This work should only be carried out by a **specialist** if it is not possible to send the FRIABILIMETER to Pfeuffer GmbH' customer service.

### DANGER



#### Touching live parts can be fatal!

The owner-operator must then ensure that a safety check is carried out according to DIN VDE 0701-0702 before the FRIABILIMETER is taken back into operation.

### CAUTION



#### Cutting injuries to hands and fingers!

The sheet metal parts of the housing may have sharp corners and edges.

⇒ Wear protective gloves.



#### Burns to hands and fingers!

The motor temperature increases during operation, reaching in excess of +40 °C!

⇒ Allow the FRIABILIMETER (motor) to cool down adequately after operation, or wear protective gloves.

### NOTICE

Keep all screws and removed small parts carefully.

Metallic housing parts must be connected to the protective earth conductor.

In this connection, make sure that

- all original parts are reinstalled in the location intended for them. no excessively long screws are used, since these can cause short circuits or damage components inside the housing.
- all grounding cables are reconnected and all screws are firmly tightened.

### CAUTION

#### Dust warning

Cereal dust can build up inside the housing.



⇒ Check whether inhaling large quantities might lead to irritation or illnesses of the respiratory passages, and if so then take appropriate measures.

⇒ **Do not** use compressed air for cleaning, since this will distribute the dust widely throughout the surrounding area.

⇒ Carefully remove the dust with an industrial grade vacuum cleaner.

**9.6.1 Renewing drive rolls**



Only renew the drive rolls if their diameter is less than 39.0 mm. Check, see **chapter 8.3**. Before you start work, pay attention to the instructions in **chapter 9.6**.



**DANGER**

**Touching live parts can be fatal!**



It is essential to comply with the switch-off procedure prior to cleaning, maintenance or repair work! (see **chapter 2.9**)

⇒ Take off the front hood and the sieve drum.

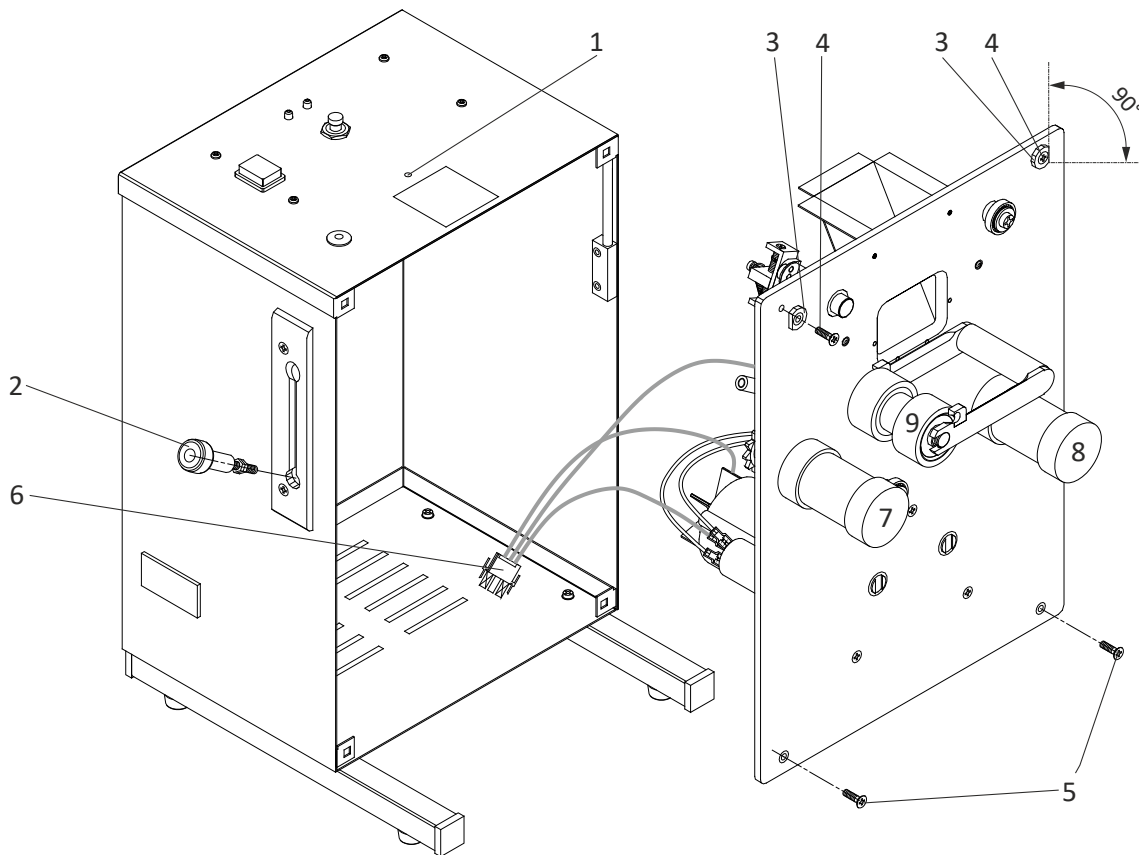

Figure 31: Opening the housing

Item	Designation
1	Rivets
2	Pull handle (bottom engagement position)
3	Serrated washer
4	Countersinking screw M4x16 mm
5	Countersinking screw M4x12 mm
6	Motor plug
7	Drive roll, left
8	Drive roll, right
9	Pressure roll



Figure 32: Drilling out rivets

- ⇒ Drill out the rivets behind the filling funnel.
- Drill bit:  $\varnothing$  3.3 mm

- ⇒ Engage the pull handle in the bottom position.
- ⇒ Unscrew the pull handle using an Allen key (4 mm).
- ⇒ Unscrew the four outer countersinking screws (M4) with a Phillips screwdriver. Pay attention to the installation position of the two upper serrated washers.
- ⇒ Carefully tilt the front plate forward.



Figure 33: Disconnecting the motor plug

- ⇒ Use your thumb and forefinger to press the sides of the motor plug together.



Figure 34: Pressing the motor plug together

- ⇒ Carefully pull the plug upward off the motor.



Figure 35: Unscrewing the chain sprocket

- ⇒ Unscrew the two upper chain sprockets using the Allen screws, with an Allen key (2 mm).



Figure 36: Pulling off the drive roll

⇒ Pull off the old drive rolls.

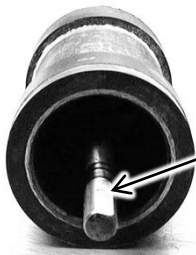

Figure 37: Drive roll

There is a flat surface on the axle of the drive rolls.

Reasons:

- Engagement surface for the Allen screw
- Ensuring force transmission onto the chain sprocket
- Ensuring the shaft/chain sprocket connection

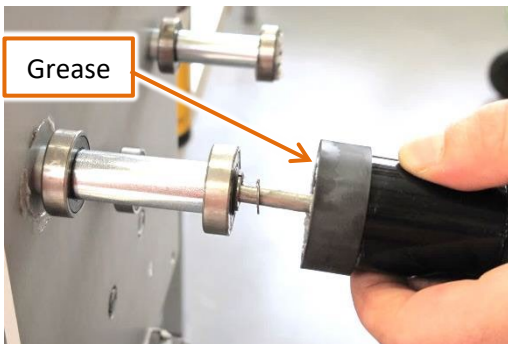

Figure 38: Putting on the drive roll

- ⇒ Grease the new drive rolls well with a spindle and anti-friction bearing grease.
- ⇒ Put on the new drive rolls.

The gap (B) between the front plate and the **left** drive roll should be about 0.8 mm.  
 The gap (B) between the front plate and the **right** drive roll should be about 0.3 to 0.5 mm.  
 The distance is set by adding 2-3 shims (Ø 6 x 0.3 mm).  
 (For gaps, see **Figure 39**. Left or right drive roll, see **Figure 31**.)

- ⇒ Make sure that the shims do not drop out when pushing on the drive rolls.
- ⇒ Retighten the two chain sprockets until finger tight using the Allen screws.
- ⇒ Check the freedom of movement of the bearings (easy to turn).

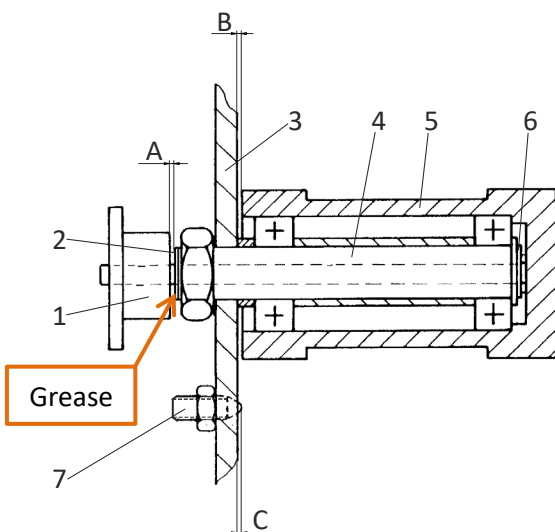

Figure 39: Drawing showing change of drive roll

- ⇒ Place a shim between the chain sprocket and bearing tube for the drive roll.
- ⇒ Grease the position well with a spindle and anti-friction bearing grease.
- ⇒ Keep a gap (A) of about 0.2 mm between the chain sprocket and bearing tube.
- ⇒ Check this gap with a feeler gage.

Item	Designation	Item	Designation
1	Chain sprocket	6	Shim $\varnothing$ 6 x 0.3 mm
2	Shim $\varnothing$ 6 x 0.3 mm	7	Sliding pin (grub screw, brass)
3	Front plate	A	Gap about 0.2 mm
4	Bearing tube	B	Right drive roll → gap about 0.3 to 0.5 mm Left drive roll → gap about 0.8 mm
5	Drive roll, rubber coated	C	Gap about 0.3 to 0.5 mm

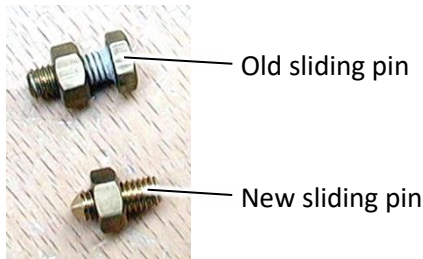

Figure 40: Sliding pins

Three sliding plates are attached to the front plate. These prevent the sieve drum from rubbing against the front plate. They project by a distance (C) of about 0.3 to 0.5 mm, see **Figure 39**.

⇒ Check this dimension and adjust it if required using a 10 mm hexagon wrench and a flat-blade screwdriver.

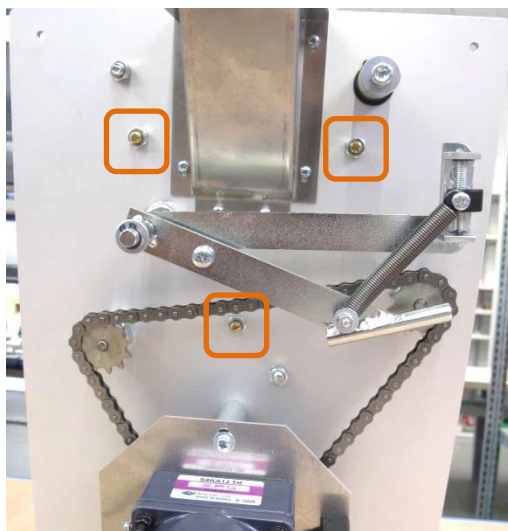

Figure 41: Positions of the sliding pins on the back of the front plate

⇒ Connect the motor plug.

⇒ Attach the front plate using the four countersinking screws. Pay attention to the correct installation position of the two upper serrated washers, see **Figure 31**.

⇒ Screw the pull handle in firmly.

⇒ Insert the sieve drum and put on the front hood.

⇒ After renewal of the drive rolls, check the device setting with test malt. It may be necessary to adjust the settings, see **chapters 8.5** and **8.6**.

⇒ Make a note of the renewal, the calibration and the subsequent check with test malt in a test log (see master copy on last page).

### 9.6.2 Renewing the timer



Only renew the timer if it is faulty.

Before you start work, pay attention to the instructions in **chapter 9.6**.



**DANGER**

**Touching live parts can be fatal!**



It is essential to comply with the switch-off procedure prior to cleaning, maintenance or repair work! (see **chapter 2.9**)

⇒ Take off the front hood and the sieve drum.

⇒ Drill out the rivets behind the filling funnel.

⇒ Engage the pull handle in the bottom position.

⇒ Unscrew the pull handle using an Allen key (4 mm).

- ⇒ Unscrew the four outer countersinking screws (M4) with a Phillips screwdriver. Pay attention to the installation position of the two upper serrated washers.
- ⇒ Carefully tilt the front plate forward.

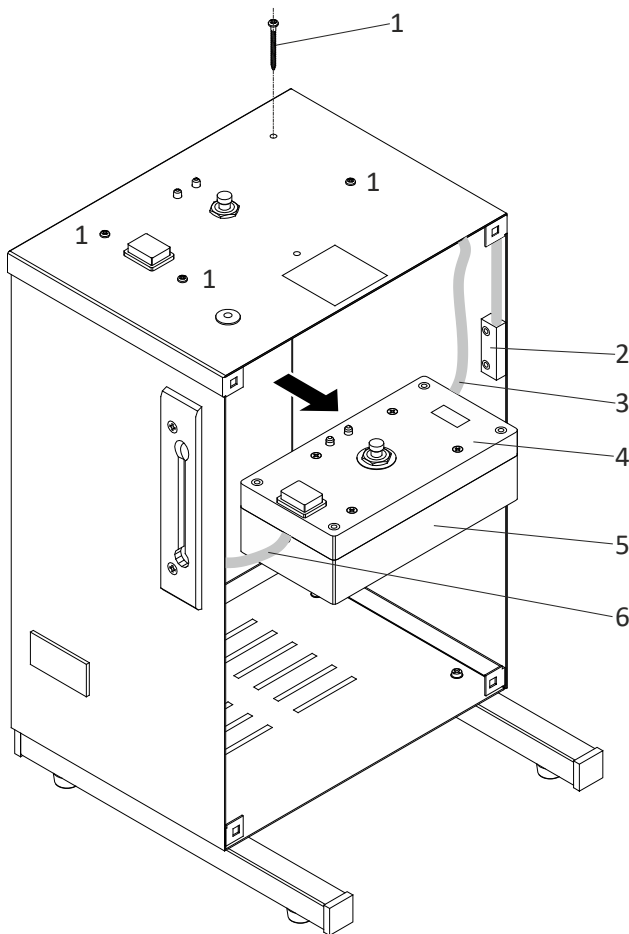

Figure 42: Timer removal

Item	Designation
1	Fillister head screw 2.9x32 mm
2	Reed switch
3	Feeder cable to Reed switch
4	Timer cover
5	Timer bottom part
6	Timer electrical power supply

- ⇒ Unscrew the four fillister head screws for the timer.
- ⇒ Pull the timer carefully downwards and out a little.
- ⇒ Remove the cover. The circuit board is in the cover:

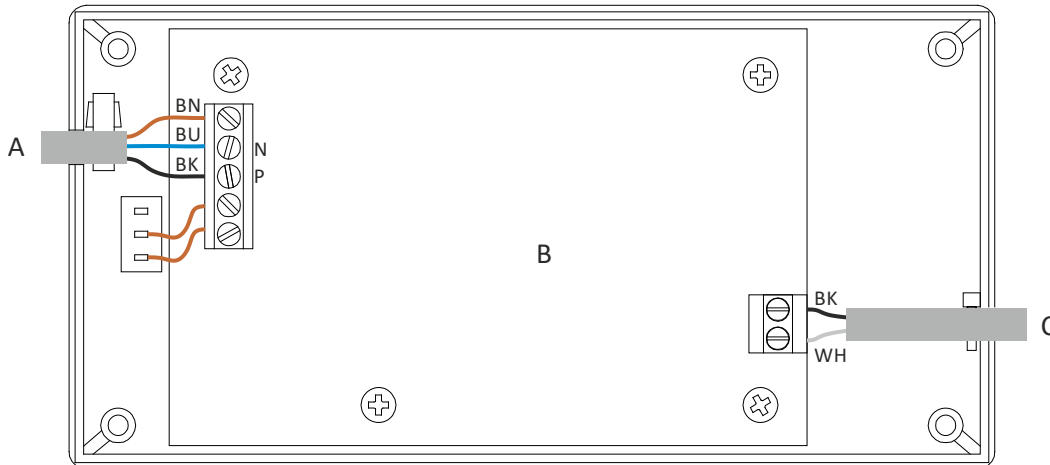

Figure 43: Timer cover circuit board until October 2020

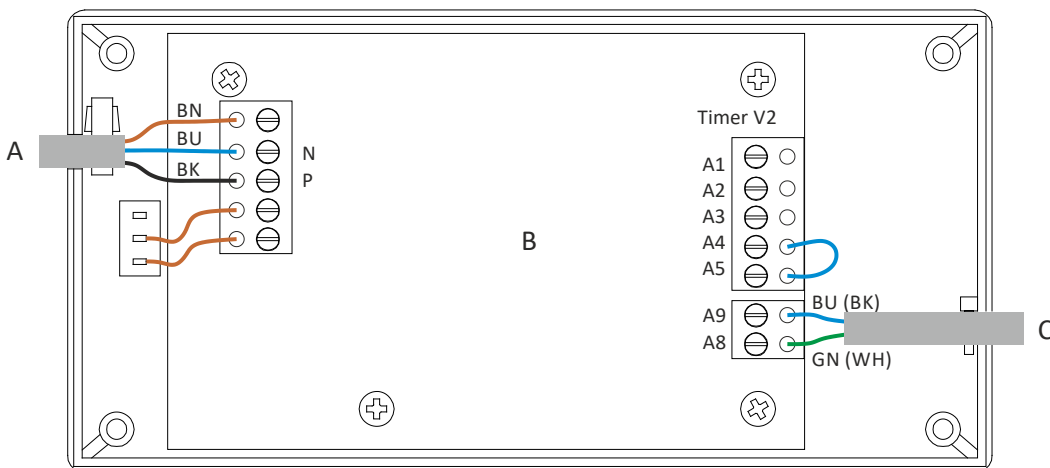

Figure 44: Timer cover circuit from November 2020

Table for abbreviations in electrical engineering, see **chapter 1.5**.

Item	Designation
A	Timer electrical power supply
B	Circuit board
C	Feeder cable to Reed switch

- ⇒ Unscrew the three screws on the connection terminal position **A** and the two screws on the connection terminal position **C**.
- ⇒ Pull off the cables.
- ⇒ Connect the cables to the new timer as shown in **Figure 43**.
- ⇒ Close the cover.
- ⇒ Screw the timer onto the housing using the four fillister head screws.
- ⇒ Attach the front plate using the four outer countersinking screws. Pay attention to the installation position of the two upper serrated washers, see **Figure 31**.
- ⇒ Screw the pull handle in firmly.
- ⇒ Insert the sieve drum and put on the front hood.



9.6.3 Renewing the motor



Only renew the motor if it is faulty.  
Before you start work, pay attention to the instructions in **chapter 9.6**.



**DANGER**

**Touching live parts can be fatal!**



It is essential to comply with the switch-off procedure prior to cleaning, maintenance or repair work! (see **chapter 2.9**)

- ⇒ Take off the front hood and the sieve drum.
- ⇒ Drill out the rivets behind the filling funnel.
- ⇒ Engage the pull handle in the bottom position.
- ⇒ Unscrew the pull handle using an Allen key (4 mm).
- ⇒ Unscrew the four outer countersinking screws M4 with a Phillips screwdriver. Pay attention to the installation position of the two upper serrated washers.
- ⇒ Carefully tilt the front plate forward.
- ⇒ Use your thumb and forefinger to press the sides of the motor plug together.
- ⇒ Carefully pull the plug upward off the motor.

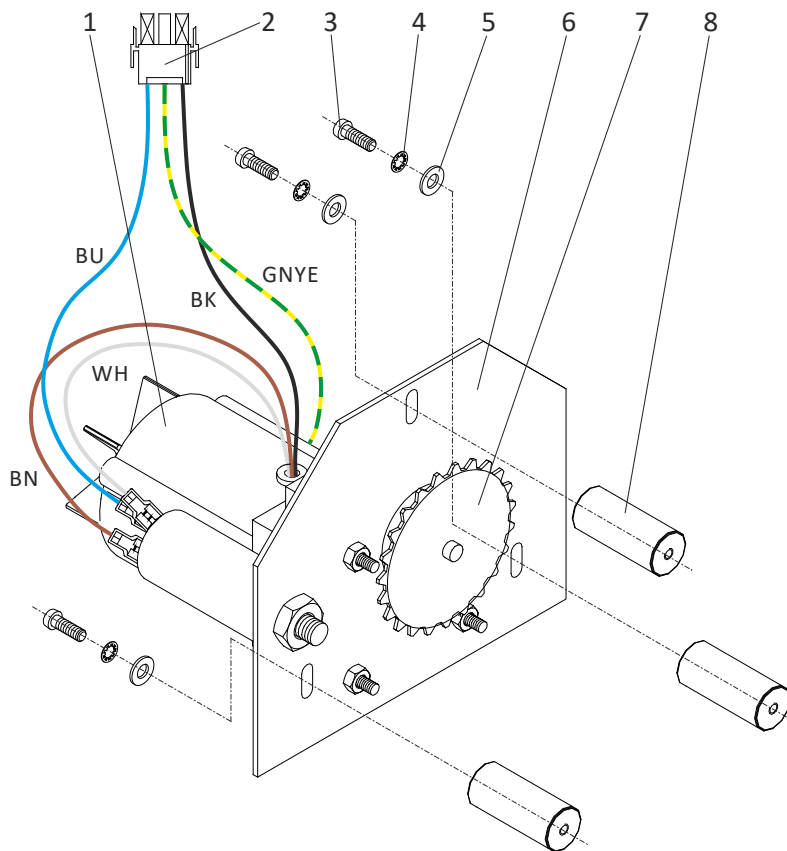

⇒ Unscrew the motor and the mounting plate from the motor pin using the three M4 fillister head screws (with lock washers and plain washers).

Item	Designation
1	Motor
2	Motor plug
3	Fillister head screw M4x12 mm
4	Lock washer M4
5	Plain washer M4
6	Motor plate
7	Chain sprocket
8	Motor pin

Figure 45: Motor, complete

Table for abbreviations in electrical engineering, see **chapter 1.5**.

⇒ Remove the chain from the chain sprocket and take off the motor.

### NOTICE

⇒ If the chain and chain sprockets are heavily contaminated, rub them clean with a dry, clean and lint-free cloth.

⇒ Grease the components lightly with a spindle and anti-friction bearing grease.

⇒ Place the chain back on the chain sprocket.

⇒ Position the new motor and the mounting plate on the motor pin using the three M4 fillister head screws (with lock washers and plain washers).

### NOTICE

⇒ Do not overtighten the chain. Otherwise, the motor and bearings might be damaged.

⇒ Allow the chain to sag slightly.

⇒ Screw the motor on firmly.

⇒ Insert the motor plug, see **Figure 33**.

⇒ Attach the front plate using the four outer countersinking screws. Pay attention to the correct installation position of the two upper serrated washers, see **Figure 31**.

⇒ Screw the pull handle in firmly.

⇒ Insert the sieve drum and put on the front hood.

⇒ After renewal of the drive rolls, check the device setting with test malt. It may be necessary to adjust the settings, see **chapters 8.5** and **8.6**.

⇒ Make a note of the renewal, the calibration and the subsequent check with test malt in a test log (see master copy on last page).

## 9.7 Checks

At the end of the work, check the following:

⇒ The work carried out is complete.

⇒ Check the wiring in the housing for kinks, chafing or charred points.

⇒ Damage on the covers or insulation.

⇒ Check that no tools have been left in or on the machine.

⇒ All subassemblies function correctly in setup or manual mode.

⇒ If all functions are correct, the machine can be handed over to the owner.

### NOTICE

Following cleaning, maintenance or exchanging wearing parts, check that all safety devices are functioning correctly.

**10 Malfunctions – causes and rectification**



The information provided in this chapter about possible malfunctions is structured to be understood by specialists in electrical, electronic or mechanical maintenance.

Appropriate tools and test instruments must be provided to these personnel. If the specified measures do not prove successful, contact Pfeuffer GmbH.

It is important for all questions to specify the correct type designation, serial number and year of manufacture. Only in this way will rapid processing be possible.



**DANGER**

**Touching live parts can be fatal!**



It is essential to comply with the switch-off procedure prior to cleaning, maintenance or repair work! (see **chapter 2.9**)

Problem	Cause	Rectification
The FRIABILIMETER does not function.	No mains voltage.  Main switch ON/OFF is in position OFF.  Internal fuse in IEC C14 power connector is defective.	Have the mains voltage checked by an <b>electrician</b> and switched on.  Set the main switch to position ON.  Test and replacement by an <b>electrician</b> , see <b>chapter 10.1</b> .
The motor no longer runs.	Defective motor	Checking and renewal by Pfeuffer GmbH or by a <b>specialist</b> , see <b>chapter 9.6.3</b> .
The green LED "On" does not light up after switch-on.	Internal fuse in IEC C14 power connector is defective.  The mains cable is not firmly connected.	Test and replacement by an <b>electrician</b> , see <b>chapter 10.1</b> .  Check all plugs are firmly seated.
The "Operation" LED lights up red.	The front hood has not been put on, or not put on correctly.	Put on the front hood correctly.
The FRIABILIMETER does not start up after the start key is pressed.	The front hood has not been put on, or not put on correctly.  Defective motor	Put on the front hood correctly.  Checking and renewal by Pfeuffer GmbH or by a <b>specialist</b> , see <b>chapter 9.6.3</b> .
The FRIABILIMETER stops working during the investigation.	Defective timer  Defective motor	Checking and renewal by Pfeuffer GmbH or by a <b>specialist</b> , see <b>chapter 9.6.2</b> .  Checking and renewal by Pfeuffer GmbH or by a <b>specialist</b> , see <b>chapter 9.6.3</b> .

Problem	Cause	Rectification
The friability result is incorrect.	<p>There are tears or holes in the wire mesh of the sieve drum.</p> <p>The pressure roll or drive roll is worn.</p> <p>The timer runtime is incorrect.</p>	<p>Renew the sieve drum.</p> <p>Check the diameter of the rolls, see <b>chapters 8.2 and 8.3</b>. Calibrate, see <b>chapters 8.5 and 8.6</b>. Renew worn parts, see <b>chapters 9.5 and 0</b>.</p> <p>Check the runtime with a stopwatch. Checking and renewal by Pfeuffer GmbH or by a <b>specialist</b>, see <b>chapter 9.6.2</b>.</p>
The friability result is incorrect after renewal of the pressure roll.	The contact pressure of the pressure roll is not correct.	Correct the setting with the setscrew, see <b>chapter 8.5</b> .

### 10.1 Renewing the internal fuse

There is a plug connection in the IEC C14 power connector on the back wall of the device. An internal glass microfuse is incorporated in this.

#### NOTICE

Always refer to the type plate for the precise fuse rating!



#### DANGER

**Touching live parts can be fatal!**



It is essential to comply with the switch-off procedure prior to cleaning, maintenance or repair work! (see **chapter 2.9**)



- ⇒ Pull out the plug connection.
- ⇒ Renew the glass microfuse.
- ⇒ Insert the plug connection back into the IEC C14 power connector.
- ⇒ The FRIABILIMETER is ready to operate again.

Figure 46: Renewal of the internal fuse

**11 Spare parts and accessories****NOTICE**

We wish to point out expressly that replacement and accessory parts not supplied by us will not have been tested and approved by us either.

Installing and/or using such products can thus result in the design properties of the FRIABILIMETER being negatively impaired.

Pfeuffer GmbH cannot be held liable for damage attributable to the use of non-genuine parts and non-genuine accessories.

Standard parts can be obtained from the dealer.

Product	Item number
FRIABILIMETER malt friability measuring instrument	1810 0000
Mains cable with removable connection (IEC power connector cable C13/C14)	2290 0100
Glass microfuse 315 mA slow blow, 5x20 mm (10x)	3253 0210
Measuring caliper	5400 8100
Can of Pfeuffer GmbH test malt 400 g	4898 0120
Flat-blade screwdriver 3 x 40 mm	5660 0050
Flat-blade screwdriver 2 x 40 mm	5660 0051
Plastic funnel	3110 0060
Collecting vessel	3110 0040
Cleaning brush	3190 0020
Cleaning brush	3190 0050
Timer, complete	2810 2010
Motor, complete	2810 0040
Front hood	2810 0110
Sieve drum	2810 0100
Drive roll	2810 0030
Pressure roll	2810 0080
Hand-held test sieve 2.2 mm (acc. to DIN EN ISO 5223) for determining the part hyaline, with base and lid	1290 5070
Laboratory sorting machine SORTIMAT	1240 0000
Riffle sample divider EBC (other models available)	1745 0020
Sample divider Vario 2H (other models available)	1745 0050

## 12 Emergency



⇒ In an emergency, disconnect the FRIABILIMETER from the electrical power supply.

## 13 Dismantling and disposal



Dismantling and disposal is only allowed to be carried out by **specialist personnel**.



**DANGER**

**Touching live parts can be fatal!**



It is essential to comply with the switch-off procedure prior to cleaning, maintenance or repair work! (see **chapter 2.9**)



### Special waste

Oil, cleaning agents, contaminated cleaning tools (brush, rags, etc.) must be disposed of according to the local regulations and in accordance with the notes in the manufacturers' safety data sheets.



Disposal with the household garbage is forbidden!

The FRIABILIMETER must be disposed of in accordance with the applicable local environmental regulations (Waste Electrical and Electronic Equipment Directive WEEE 2012/19/EU).

## 14 Literature

### Literature used

- Analysis Committee of the EBC<sup>11</sup>: ANALYTICA-EBC, 4th edition 1987, supplement 1989, Zürich; chapter 4.15 Friability and hyaline; latest version: September 1997
- Technical Committee and Editorial Committee of the ASBC<sup>12</sup>, 8th edition, 1988, St. Paul, Minnesota: ASBC-Analytica, Chapter Malt-12, Malt modification by friability
- Prof. Dr. F. Drawert (MEBAK<sup>13</sup>): Brautechnische Analysenmethoden, Vol. I, 1984, Freising-Weihenstephan
- MEBAK Brautechnische Analysenmethoden, Vol. Rohstoffe, 1st edition 2006, Freising-Weihenstephan

### Other literature

- L. Chapon, Tageszeitung für Brauerei 75, 160 (1978)
- K.F. Kretschmer and L. Chapon, Brauwissenschaft 31, 274 (1978)
- L. Chapon, Monatsschrift für Brauerei 32, 160 (1977)
- D.A. Thomas, Journal of the Institute of Brewing 92, 65 (1986)
- E.D. Baxter and D.D. O'Farrell, Journal of the Institute of Brewing 89, 210 (1983)
- P.A. Martin and I.C. Cantrell, Journal of the Institute of Brewing 92, 367 (1986)
- M. Benard, Monatsschrift für Brauwissenschaft 45, 122 (1992)

<sup>11</sup> European Brewers' Convention

<sup>12</sup> American Society of Brewing Chemists

<sup>13</sup> Central European Brewing Analysis Commission

**15 Test log**

This log is intended to allow the owner-operator to document the test status of the FRIABILIMETER.

Company, location \_\_\_\_\_  
 Year of manufacture \_\_\_\_\_  
 Serial number \_\_\_\_\_  
 Operating hours \_\_\_\_\_

Company stamp:

**Check**

**Before each check, first carry out an investigation and dispose of this sample afterwards without logging the values.**

Chapter	Designation	Findings (please mark with a cross)			Calibration carried out
8.1	<b>Timer runtime</b>				
	Measured:	<input type="checkbox"/> 8 min ± < 5 s		<input type="checkbox"/> 8 min ± > 5 s	Not applicable
	Measure:	OK		Client service	
8.2	<b>Pressure roll</b>				
	Measured:	<input type="checkbox"/> Ø > 39.5 mm	<input type="checkbox"/> Ø 39.5 to 39.0 mm	<input type="checkbox"/> Ø < 39.0 mm	<input type="checkbox"/>
	Result:	OK	Recalibrate!	Renew!	
8.3	<b>Drive roll</b>				
	Visible abrasion:	<input type="checkbox"/> None	<input type="checkbox"/> Slight	<input type="checkbox"/> Severe	Not applicable
	Measure:	OK	Measure!	Renew!	
	<b>Drive roll</b>				
	Measured:	<input type="checkbox"/> Ø > 39.5 mm	<input type="checkbox"/> Ø 39.5 to 39.0 mm	<input type="checkbox"/> Ø < 39.0 mm	<input type="checkbox"/>
Result:	OK	Recalibrate!	Renew!		
8.4	<b>Sieve drum</b>				
	Damaged:	<input type="checkbox"/> No		<input type="checkbox"/> Yes	<input type="checkbox"/>
	Result:	OK		Renew!	

The tester confirms that the check has been carried out correctly as described in the operating instructions in **chapter 8** (Checking the device settings).

**Investigation with test malt**

All values in grams	Friability	Whole hyaline	Part hyaline
1. Investigation			
2. Investigation			
3. Investigation			
Average value (ACT)			
Standard (NOM)			
Deviation			

The tester confirms that the investigation has been carried out correctly as described in the operating instructions in **chapter 7** (Operation).

The FRIABILIMETER meets the requirements placed on it:  Yes  No

Place, date \_\_\_\_\_ Name, position \_\_\_\_\_ Signature \_\_\_\_\_