



PFEUFFER

Operating Instructions



Laboratory sorting machine

Sortimat



Type **K3, K4** or **K5**

PFEUFFER GmbH

Flugplatzstraße 70
97318 Kitzingen
GERMANY

Phone: +49 9321 9369-0

info@pfeuffer.com
www.pfeuffer.com

Revision 2/18.03.2024
Translation of the original operating instructions

Item number operating instructions:
Artikelnummer Betriebsanleitung:

1240 0321



These operating instructions form part of the SORTIMAT laboratory sorting machine and must be available to the operating personnel at all times. They are intended for the owner of the system, the operating personnel and the specialists who are responsible for transport, installation, setup, commissioning, maintenance, cleaning, dismantling and disposal.

The Pfeuffer GmbH has prepared and reviewed these Operating Instructions with the greatest care. However, no guarantee is made for its completeness or accuracy.

Subject to technical modifications.

Translation

In the event of delivery of subsequent sale to the countries of the European Economic Area (EEA), the operating instructions must be translated into the corresponding language of the country of use.

In the event of discrepancies in the translated text, the original operating instructions (German) must be used for clarification, or the manufacturer must be contacted.

Operating instructions in electronic format

The original operating instructions (German) and translations of the original operating instructions can be requested as PDF files by e-mail. Specifying the correct type designation and serial number is important for further processing!

© Copyright

This document is not allowed to be communicated or duplicated, utilized without express permission, which also applies to communicating its content. Offenders are liable to the payment of damages. All rights reserved with regard to patent claims or submission of design or utility patent.

(DIN ISO 16016)

1	Introduction	4
1.1	Designated use.....	4
1.2	Structural features of the danger notes.....	4
1.3	Pictograms in the operating instructions.....	5
1.4	Identification.....	5
1.5	Declaration of Conformity.....	6
2	Safety	7
2.1	Built-in safety systems	7
2.2	Elektrical connections	8
2.3	Operating and danger areas on the SORTIMAT	8
2.4	Operating and maintenance personnel	8
2.5	Safety measures (to be carried out by the owner)	9
2.6	General safety notes	10
2.7	Safety tests.....	10
2.8	Residual dangers in connection with the SORTIMAT	10
2.9	Switch-off procedure	11
3	Technical data	11
3.1	Dimensions and weight.....	11
3.2	Power supply.....	11
3.3	General data	11
3.4	Machine type designation.....	11
4	Delivery, transport and storage	12
5	Installation and commissioning	14
6	Function	16
6.1	Overview	16
6.2	Sequence of functions.....	16
7	Operation	17
7.1	Control elements	17
7.2	Sample preparation measures	17
7.3	Selecting sieves	18
7.4	Weighing out the sample	19
7.5	Filling the sample	19
7.6	Using broken and round grain separating device (option).....	19
7.7	Switching the SORTIMAT on and off	21
7.8	Emptying the sample	21
7.9	Weighing fractions	22
7.10	Correction table	22
8	Maintenance and cleaning	23
8.1	Cleaning	23
8.2	Maintenance	24
8.2.1	Lifting off the sieve stack.....	24
8.2.2	Replacing sieves	25
8.2.3	Exchanging the spring brackets on the sieve cleaning device	27
8.3	Inspection interval and function test	28
9	Malfunctions – causes and rectification.....	28
9.1	Renewing the internal fuse	30
10	Spare and wearing parts.....	31
11	Supplements and accessories	32
12	Emergency.....	33
13	Dismantling and disposal.....	33
14	DIN ISO 9001 – documentation.....	34
14.1	Test log for nominal hole widths.....	35
14.2	Test log for sorting test	36

1 Introduction

1.1 Designated use

The SORTIMAT is a laboratory sorting machine for sorting and sifting agricultural grain crops and products made from them. Its use focuses on determining the boldness of brewing barley. The SORTIMAT can be used for assessing the quality of cereals, leguminous crops, oil seeds and pellets. The SORTIMAT is an efficiently operating sorting machine for a sample quantity of 100 g. The tilting sieve stack and the integrated sieve cleaning device make it possible to process several samples in the shortest possible time. There is no need for time-consuming dismantling and cleaning after each sorting. The laboratory sorting machine is available in three variants, with three, four or five sieves. The SORTIMAT consists of a mechanical shaking device with an electric motor and an electronic timer for controlling the sieving time.

The SORTIMAT is designed as a portable device with a mains plug for indoor use (laboratory environment).

Private use of the SORTIMAT is not allowed.

NOTICE

The SORTIMAT has been exclusively designed for the aforementioned purpose.

Any other use beyond this definition or conversion of the system without written consultation with the manufacturer is regarded as not in accordance with the designated use. The manufacturer will not be liable for any damage resulting from this. The risk is the responsibility of the owner alone.

The SORTIMAT is only allowed to be taken into operation if it can be ensured that all safety devices are functioning.

Filling liquid and sticky products is prohibited!

The SORTIMAT is not suitable for sorting flours, dusts and meals!

The products to be used in accordance with the designated use of the SORTIMAT are obtained by the owner of the SORTIMAT.

Correct treatment of these materials and the associated risks are exclusively the responsibility of the owner.

The owner must provide information about dangers and disposal.

The designated use also includes complying with the operating instructions as well as the maintenance and servicing conditions as defined in these operating instructions.

These operating instructions do not release the owner from its responsibility to develop and apply, or have applied, health and/or safety regulations appropriate for the requirements of the overall system, and to monitor compliance with the same.

1.2 Structural features of the danger notes

The operating instructions from Pfeuffer GmbH contain instructions that you must comply with for your personal safety as well as to avoid damage to property. The instructions for your personal safety are highlighted by a warning triangle.

Comply with the following categories of danger notes and explanations of symbols:

Pictogram

SIGNAL WORD



Type of danger and its source.

Possible consequence of failure to comply.

⇒ Measure to guard against the danger.

DANGER

This is a warning about a highly dangerous situation that will lead to serious or fatal injuries.

WARNING

This is a warning about a dangerous situation that may result in serious or fatal injuries.









CAUTION

This is a warning of a possibly dangerous situation that will lead to slight or moderate injuries.

NOTICE

This is a warning about harmful situations for the product and/or environment.

1.3 Pictograms in the operating instructions

	Notes of particular importance and/or additional information		Warning of electrical voltage
	Comply with the operating instructions		Warning of hand injuries
	Pull out mains plug		Recycling marking – Supply refuse for recycling
	Protective earth connection		Disposal with the household garbage is forbidden!
	Warning		

1.4 Identification

Pfeuffer GmbH Flugplatzstraße 70 97318 Kitzingen	Tel. +49 9321 969-0 info@pfeuffer.com www.pfeuffer.com	PFEUFFER
Sortimat K3		
Laborsortiermaschine/Laboratory sorting machine		
S/N	00000000	
Baujahr/YOM	0000	
Spannung/Voltage	0000	
Leistung/Power	0000	
Sicherung/Fuse	0000	
		 Made in Germany

The information in these operating instructions applies exclusively to the device with the type designation indicated on the title sheet.

The type plate is located on the back of the device.

It is important for all questions to specify the correct type designation, serial number and year of manufacture. Only in this way will rapid processing be possible.

1.5 Declaration of Conformity**EC/EU Declaration of Conformity**

In accordance with the EC/EU Directives

- Machinery 2006/42/EC
- Electromagnetic Compatibility (EMC) 2014/30/EU
- Restriction of the use of certain hazardous substances in electrical and electronic equipment (RoHS) 2011/65/EU

Manufacturer: **PFEUFFER**
Pfeuffer GmbH
Flugplatzstraße 70
97318 Kitzingen
GERMANY

Phone: +49 9321 9369-0
info@pfeuffer.com
www.pfeuffer.com

The manufacturer bears sole responsibility for issuing this Declaration of Conformity.

Person authorized to compile the technical documents: Lothar Pfeuffer, General Manager

Product: Laboratory sorting machine **Sortimat**

Type: **K3**, **K4** or **K5**

Serial number: _____

The aforementioned product complies with the requirements of the following harmonized standards:

DIN EN ISO 12100:2011-03+A1:2013 (EN ISO 12100:2010)

DIN EN 61010-1:2020-03 (EN 61010-1:2010+A1:2019)

DIN EN 61000-6-2:2019-11 (EN 61000-6-2:2019)

DIN EN 61000-6-3:2011+A1:2012 (EN 61000-6-3:2007+A1:2011)

EN IEC 63000:2018

Any modification to the SORTIMAT laboratory sorting machine not agreed with us shall result in this declaration losing its validity.

Kitzingen, _____

Lothar Pfeuffer, General Manager

2 Safety

NOTICE

It is strictly prohibited to deactivate the safety devices or modify their mode of effect.

2.1 Built-in safety systems

The built-in safety systems must be checked at regular intervals with the corresponding test methods, see the following table:

Test intervals	Test methods
d = Daily	V = Visual check
w = Weekly	F = Function check
m = Monthly	M = Measurement
$\frac{1}{4}$ y = Every three months	
$\frac{1}{2}$ y = Every six months	
y = Yearly	

Mains disconnecter in a portable device

Test	
Interval	Method
m	F

The main switch **On/Off** is the mains disconnecter, and also serves as the EMERGENCY OFF function. It is located on the front of the device.

The connection for the mains cable (IEC 60320 C14 power connector) is located on the back of the device.

NOTICE

Removable mains cables must not be replaced by inadequately dimensioned mains cables. Only the specified mains cables may be used!



- ⇒ In an emergency, switch off the SORTIMAT using the main switch, position **Off**.
- ⇒ Disconnect the mains cable from the electrical power supply or unplug the IEC 60320 C13 power coupling.
- ⇒ Secure the mains cable appropriately against unauthorized reconnection by placing it where it can be monitored continuously.
- ⇒ Ensure that the mains cable is never a tripping hazard or that someone can become caught or step on it.



Electrical connections, see **chapter 2.2**.



Arrange the plug/socket combination at the place of installation so that it can be observed clearly and reached quickly in an emergency.

Protective covers

Test	
Interval	Method
m	V

The SORTIMAT features protection against reaching into the machine, in the form of the complete housing.

Safety spring on the sieve stack

Test	
Interval	Method
d	F

The sieve stack on the SORTIMAT has a built-in safety spring as a locking unit so that the sieve stack does not tip backwards after installation.



Figure 1: Position of safety spring during operation

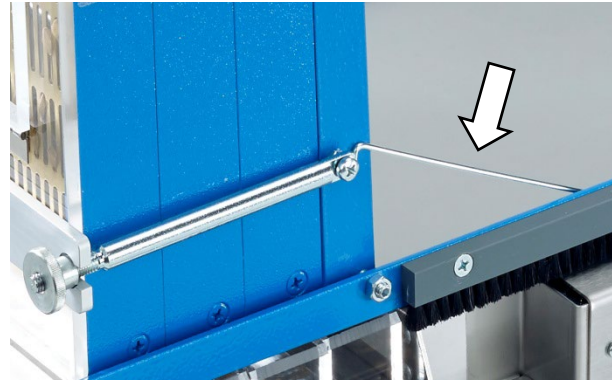

Figure 2: Position of safety spring when sieve stack is set up

CAUTION

Bruises and cuts on hands and fingers!



- ⇒ Make sure that the safety spring is always in the correct installation position.
- ⇒ Loosen the safety spring by pressing downwards.
- ⇒ Replace the safety spring immediately if it is bent or if the pressure is too easy to loose. Item number see **chapter 10**.

2.2 Elektrical connections

The SORTIMAT may only be operated with the specified voltages. The fuse must always be replaced with identical specified values, see **chapter 3.2** and information on the type plate.



The SORTIMAT is only allowed to be connected to a socket earthed in accordance with the regulations, using a protective conductor.

2.3 Operating and danger areas on the SORTIMAT

Operating area

Make sure the installation height is sufficient (according to the stature of the operating personnel). A suitable base (e.g. table) is required for this.

Danger area

The entire area one meter around the SORTIMAT is a danger area during maintenance and repair work. Keep the area around the SORTIMAT clear of objects.

2.4 Operating and maintenance personnel

Operating and maintenance personnel are people who are responsible for transport, assembly, installation, operation, setup and cleaning of the SORTIMAT, and for eliminating malfunctions.

1. The SORTIMAT is only allowed to be operated by authorized and instructed people.
2. The responsibilities for operating the SORTIMAT must be clearly defined and complied with so that no unclear competencies arise with regard to the aspect of safety.

3. The switch-off procedures specified in the operating instructions must be complied with during all work (operation, maintenance, repair, etc.), see **chapter 2.9**.
4. The operator must refrain from any working method that impairs safety on the SORTIMAT.
5. The owner must ensure that only authorized people work on the SORTIMAT.
6. The owner is obliged to report immediately to the owner any changes that take place on the SORTIMAT which impair safety.
7. The operating personnel must be provided by the owner with appropriate protective equipment in accordance with legal requirements and the material to be processed.
8. The owner must issue regular instructions regarding the use of personal protective equipment, and must check such equipment is being used.

2.5 Safety measures (to be carried out by the owner)

It should be noted that the owner is responsible for the following aspects with regard to the operating and maintenance personnel

- ⇒ Providing instruction in the protective devices for the SORTIMAT
- ⇒ Monitoring compliance with the safety measures.

The frequency of the function tests described in **chapter 8.3** must be complied with.

The work described in these operating instructions is configured in such a way that

- ⇒ it is explained in the chapters Function and Operation for the operating personnel
- ⇒ it is explained in the chapters Delivery, Transport and storage, Installation and commissioning, Maintenance and cleaning, Malfunctions – causes and rectification and Dismantling and disposal for a specialist operator.

The chapters Delivery, Transport and storage, Installation and commissioning, Maintenance and cleaning, Malfunctions – causes and rectification and Dismantling and disposal are only intended for **specialist operators**. Work described in this chapter is only to be carried out by **specialist operators**.

Instructed person

A person who has been instructed and, if necessary, trained by a **specialist operator** regarding the tasks assigned to him/her and the possible dangers in the event of incorrect conduct, and who has also been instructed regarding the necessary protective devices and protective measures.

Specialist operator

An individual who, due to his/her relevant specialist training and/or experience, is capable of recognizing risks and avoiding dangers that may occur during use of the product.

(Definition according to DIN EN 82079-1:2013-06)

Qualified electrician

Person who is in a position to carry out work on electrical systems and independently recognize potential dangers on the basis of their technical training, knowledge and experience and knowledge of the relevant standards and provisions. Qualified electricians are specially trained for the working environment in which they work and have knowledge of the relevant standards and provisions.

Obligations on the owner



In the European Economic Area (EEA), national implementation of the framework directive 89/391/EEC and corresponding individual directives, in particular the directive 2009/104/EC concerning the minimum health and safety requirements for the use of work equipment by workers at work, as amended, are to be observed and adhered to.

In addition, he/she must comply with the local legal requirements on:

- ⇒ Safety of personnel (accident prevention regulations)
- ⇒ Accident prevention regulation DGUV¹ Regulation 3 (previously BGV A 3) "Electrical systems and equipment"
- ⇒ Safety of work equipment (protective equipment and maintenance)
- ⇒ The permissible noise load, depending on the location and the time of day (TRLV² apply in Germany)
- ⇒ Product and material disposal (waste legislation)
- ⇒ Cleaning (cleaning agents and disposal)
- ⇒ Hazardous substances (in Germany TRGS³ 555 apply)
- ⇒ Environmental protection regulations.

2.6 General safety notes



The safety equipment and safety notes described in these operating instructions must be complied with.



1. Disconnect the SORTIMAT from the mains if there are malfunctions.
2. Disconnect the SORTIMAT from the mains before cleaning work.
3. Do not allow the SORTIMAT to get wet during transport, storage, cleaning and operation.
4. Make sure that the SORTIMAT is only operated when in correct working order.
5. Never touch the mains cable with moist hands.
6. Only use genuine spare parts and accessories.

2.7 Safety tests

Pfeuffer GmbH carried out the following safety tests at the factory:

Testing and checking according to DIN EN 60204-1:

- Check that the electrical equipment is in compliance with the technical documentation.
- Continuous connection of the protective earth system
- Insulation resistance tests
- Voltage tests
- Protection against residual voltages
- Function tests

The functions of the electrical equipment, in particular those relating to safety and protective measures, have been tested.

2.8 Residual dangers in connection with the SORTIMAT

- ⇒ During all work on electrically operated components, pay attention to dangers from electrical current.

¹ DGUV = Association of German Statutory Accident Insurance

² TRLV = Technical Rules of the Noise and Vibration Occupational Safety and Health Ordinance

³ TRGS = Technical Rules for Hazardous Substances

2.9 Switch-off procedure

DANGER



Touching live parts can be fatal!

It is essential to comply with the following switch-off procedure prior to cleaning, maintenance or repair work (only by specialist personnel):

- ⇒ Empty the SORTIMAT.
- ⇒ Switch off the SORTIMAT using the main switch, position **Off**.



⇒ Disconnect the mains cable from the electrical power supply or unplug the IEC 60320 C13 power coupling.

- ⇒ The mains cable must be able to be kept under the direct supervision of the person in the danger area.

3 Technical data

SORTIMAT	Laboratory sorting machine
Sample amount	100 g
Product	Cereals, leguminous crops, oil seeds and similar bulk goods in granulate form (pellets)
Sorting time	Variably adjustable using the timer (1-9 minutes)

3.1 Dimensions and weight

Height	350 mm
Width	270 mm
Length	500 mm
Weight	27 kg

3.2 Power supply

Operating voltage/frequency	230 V _{AC} , 50 Hz or 115 V _{AC} , 60 Hz, on request
Power consumption	40 VA
Number of phases	1-ph / PE
Protective earth conductor	PE (yellow/green) in the mains cable
Internal fuse	1 A slow-blow glass microfuse 250 V, 5x20 mm
Mains cable	With removable supply cable (IEC connector cable); 10 A, 250 V
Installation regulations	Configured according to VDE

3.3 General data

Ambient temperature storage and transport	-10 °C to +60 °C
Ambient temperature in operation	+5 °C to +40 °C
Atmospheric humidity	20 % - 80 %, non-condensing

3.4 Machine type designation

e. g. SORTIMAT K3

K	Grain crops	3	Number of sieves 3, 4 or 5
---	-------------	---	----------------------------

4 Delivery, transport and storage



The Delivery, transport and storage chapter is only intended for **specialist operators**.

Scope of delivery

The standard scope of delivery to the owner comprises: Laboratory sorting machine SORTIMAT K3, K4 or K5, sieves (optional, acc. to delivery note), drawer with 4, 5 or 6 collecting vessels, mains cable with removable connection (IEC connector cable), cleaning brush, operating instructions.

The selection of sieves depends on the product. Order the various sieves separately from Pfeuffer GmbH.

Transport and packaging

Systems, machines and devices from Pfeuffer GmbH are carefully tested and packaged prior to dispatch, however it is not possible to exclude the risk of damage during transport.

Incoming check

Check for completeness with reference to the delivery note.

In case of damage

Check the delivery for damage (visual inspection).

In case of complaints

If the delivery suffered damage in transit:

- ⇒ Keep the packaging (to allow it to be checked subsequently by the forwarding company, or for sending back).
- ⇒ Immediately inform the supplier or Pfeuffer GmbH.

Intermediate storage

The freight packaging of the SORTIMAT and the accessory/replacement parts is configured for a storage duration of up to six months from delivery.

- ⇒ Do not place any heavy objects on the packaging.

Storage conditions

Enclosed, dry room with a room temperature between min. -10 °C and max. 60 °C.

Transport to the installation site (by the customer)



The transport is only allowed to be undertaken by **specialist personnel** according to the local conditions and any information indicated on the packaging material.

Unpacking

- ⇒ Open the packaging.

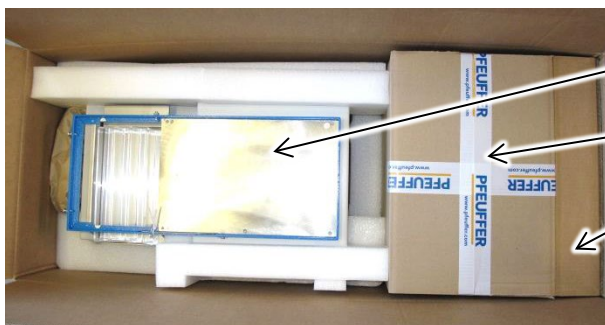

- Sortimat
- Sieve stack
- Accessories

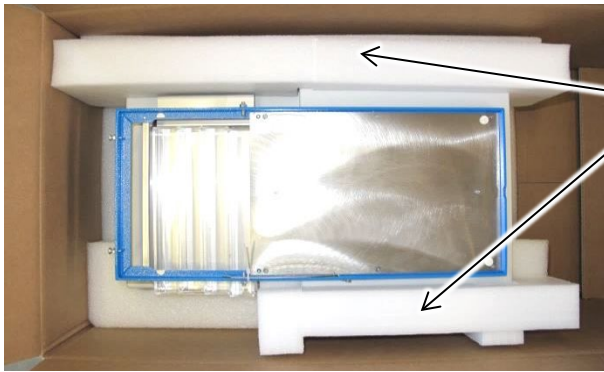

⇒ Remove the both PE foam padding at the side.



⇒ Lift the SORTIMAT out of the box using its carrying handles attached at the sides.

⇒ Note that the weight is approx. 27 kg.

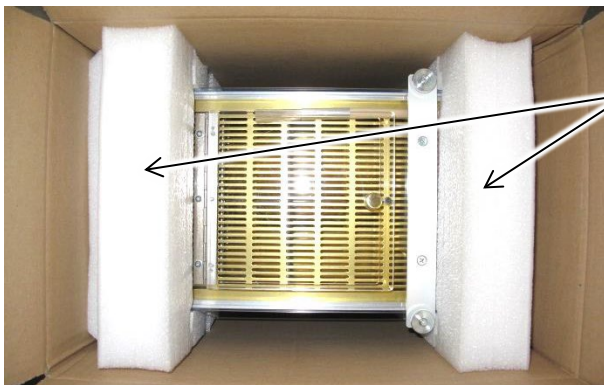

⇒ Open the packaging with the sieve stack.

⇒ Remove the both PE foam padding at the side.

⇒ Lift the sieve stack out carefully.

⇒ Move the SORTIMAT to the installation location, paying attention to the setup instructions in **chapter 5**.

⇒ Keep the original packaging.

Packaging for return delivery

⇒ If possible, use the original packaging and the original packaging material. If neither is available any longer, request new packaging from Pfeuffer GmbH.

WARNING



Risk of suffocation

Packaging materials (e.g. film, polystyrene, cardboard boxes) can be dangerous to children.

⇒ Keep packaging material away from children.

⇒ Do not leave packaging material lying around carelessly.

⇒ Dispose of packaging material in an environmentally friendly way.



5 Installation and commissioning



The Installation and commissioning chapter is only intended for **specialist operators**.

Installation

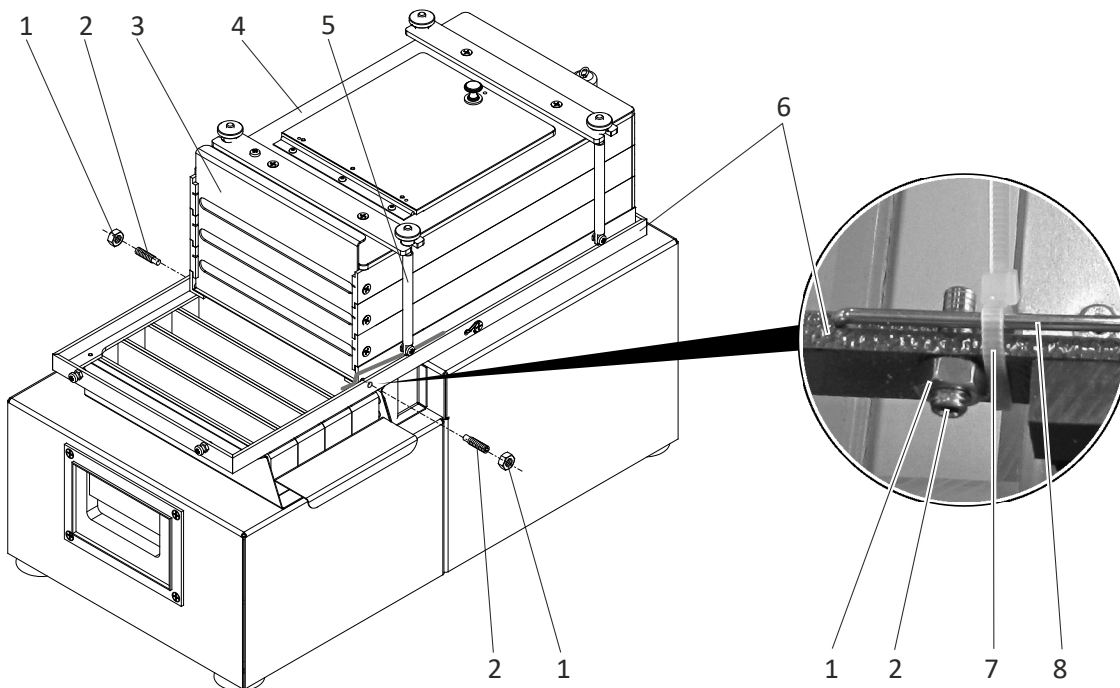

Figure 3: Initial installation of sieve stack following delivery

Item	Designation
1	M5 hexagon nut
2	M5 grub screw with hexagon socket
3	Slide
4	Sieve stack
5	Holding screw on the sieve stack
6	Carrier frame
7	Cable tie
8	Safety spring (locking unit)

⇒ Carefully unpack the SORTIMAT (see **chapter 4**).

The sieve stack (incl. sieve cleaning device) are supplied separately by Pfeuffer GmbH. This is because of the sensitivity of the support springs. Install the sieve pack as follows:

- ⇒ Unscrew the two hexagon nuts (8 mm) and grub screws (2.5 mm hexagon socket) on the carrier frame.
- ⇒ Remove the cable tie on the safety spring (locking unit).
- ⇒ Put on the sieve stack.
- ⇒ Make sure that the safety spring is installed in the correct position below the holding screw of the sieve stack, see the following figure.
- ⇒ Safety instructions see **chapter 2.1**.

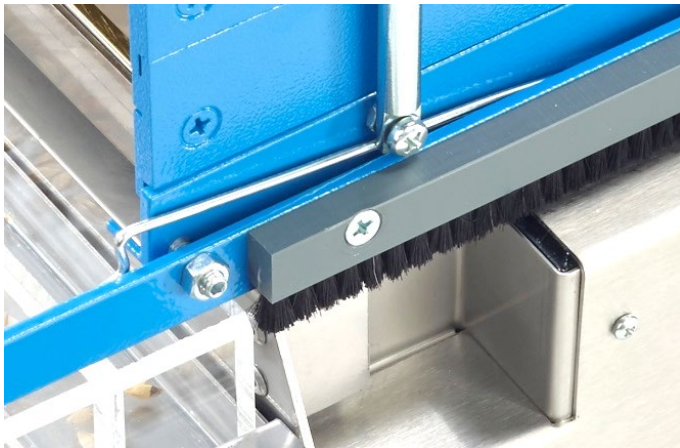

Figure 4: Correct installation position of the safety spring below the holding screw of the sieve stack

⇒ Screw the sieve stack firmly onto the carrier frame using the two hexagon nuts and grub screws.



On the Youtube® channel of Pfeuffer GmbH, there is a film showing the installation of the sieve stack on the SORTIMAT:

<https://www.youtube.com/user/PfeufferCOM>



- ⇒ Place the SORTIMAT level on a solid table (weight = 27 kg). The surface should be smooth and clean so that the suction cups will grip well.
- ⇒ The SORTIMAT exerts vibration forces on the base, because of the back-and-forth movements of the sieve stack. Do not set up the SORTIMAT close to apparatus/devices that are sensitive to vibration.
- ⇒ Make sure there is an adequate distance to all sides so that no heat buildup can occur.
- ⇒ Make sure there is sufficient clearance above, because the sieve stack of the SORTIMAT is tipped by 90°.
- ⇒ Do not set up the SORTIMAT close to apparatus/devices that are sensitive to dust.
- ⇒ Avoid exposure to direct sunlight and extreme ambient conditions.
- ⇒ Make sure that the installation height is ergonomic according to the stature of the operating personnel.
- ⇒ Connect the supplied mains cable to the SORTIMAT. The power connector (IEC 60320 C14) is located on the back of the device.



⇒ Connect the plug of the mains cable to a suitably earthed socket with protective earth conductor.

⇒ Take the SORTIMAT into operation according to the instructions in **chapter 7**.

6 Function

6.1 Overview

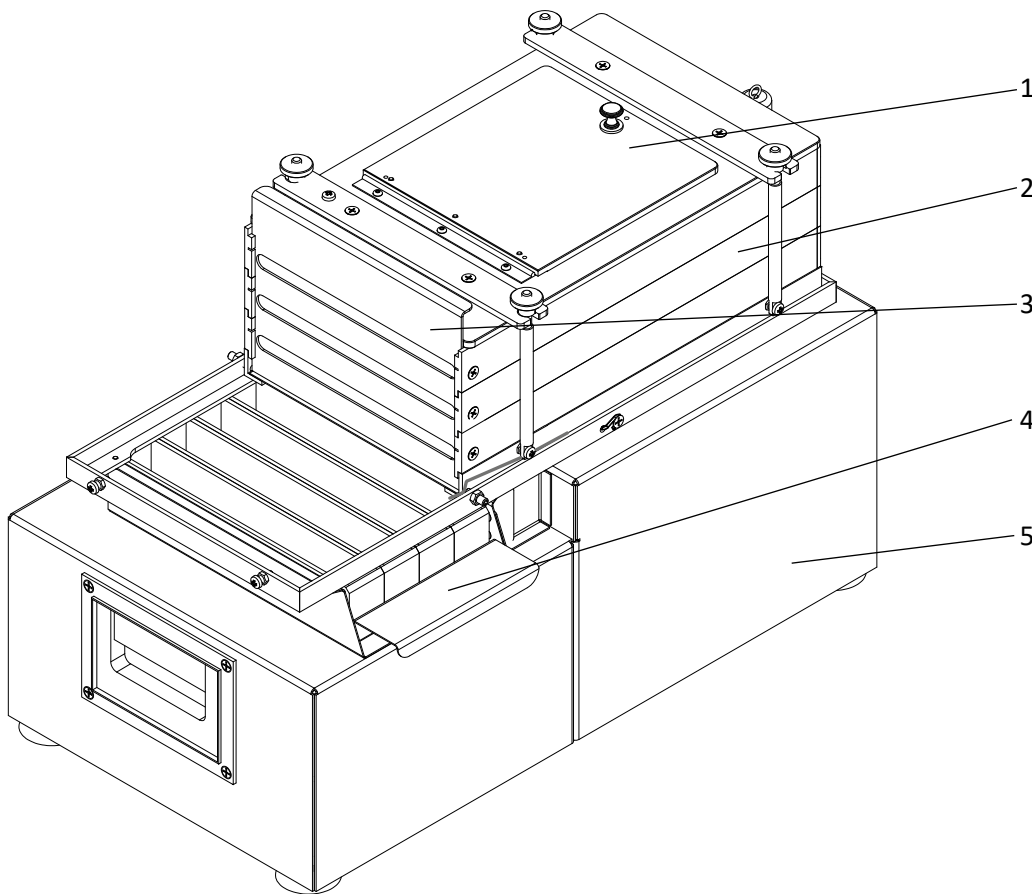

Figure 5: Overview

Item	Designation
1	Cover
2	Sieve stack
3	Slide
4	Drawer with collecting trays
5	Housing with drive and electronics

6.2 Sequence of functions

The SORTIMAT is a laboratory sorting machine for sorting and sifting agricultural grain crops and products made from them.

Weigh out a cleaned sample of 100 g on a balance with 0.01 g accuracy, and place on the uppermost sieve. Preselect the sieving time on the built-in timer (coding switch, 1 to 9 minutes). A standard sieving time of 3 minutes is recommended for sorting cereals. Press the start button. The SORTIMAT separates the sample into individual fractions by even shaking movements. At the end of the sieving procedure, push in the drawer with collecting trays for the individual fractions. Set up the sieve stack and open the slide. The fractions of the sample drop into the collecting trays. The sieve cleaning device removes almost all of the grains that remain in the sieve slits. To do this, pull the pull handle upwards and then push it back down. Remove the drawer for weighing the individual fractions.

For precise information about operation, refer to **chapter 7**.

7 Operation

 The SORTIMAT laboratory sorting machine is only allowed to be operated by personnel who have been qualified and trained in its operation.

7.1 Control elements

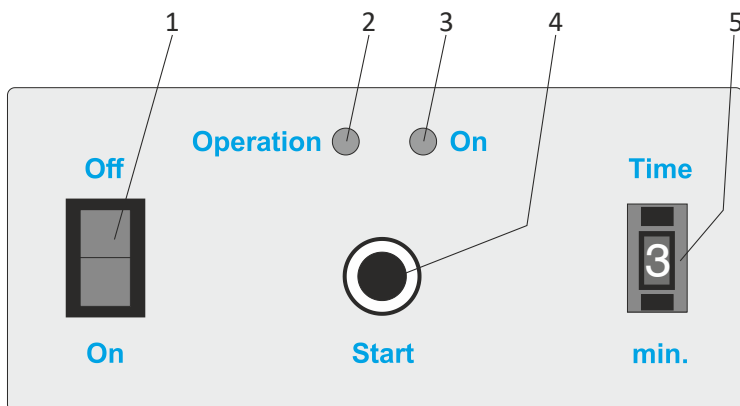

Figure 6: SORTIMAT control elements

Item	Designation
1	Main switch On/Off
2	Operation LED
3	On LED
4	Start key
5	Coding switch (sorting time)

Main switch On/Off

The main switch switches the SORTIMAT on and off. After switching on, the "On" LED lights up.

Start key

The start key starts the sorting. The "On" LED goes out and the "Operation" LED lights up. The SORTIMAT switches off automatically after the set sorting time.

Coding switch (sorting time)

Use the coding switch to set the required duration of sorting (1-9 minutes).

7.2 Sample preparation measures

NOTICE

Select a **representative sample** for the sorting.

For information and notes about sampling, refer to the standard: DIN EN ISO 24333: 2010 Cereals and cereal products – Sampling or the regulations of ICC⁴, EBC⁵ and MEBAK⁶.

Optimum results can be achieved with **cleaned samples**. **Foreign bodies** must be **removed prior to the sorting!**

Practical experience has established that a **sample quantity** of **100 g** achieves an accurate result.

⁴ International Association of Cereal Chemists
⁵ European Brewers' Convention
⁶ Central European Brewing Analysis Commission

CAUTION



Dust warning

Due to the nature of the samples, visible cereal dust will be released into the surroundings during operation.

⇒ Check whether inhaling large quantities might lead to irritation or illnesses of the respiratory passages, and if so then take appropriate measures.

7.3 Selecting sieves

Before starting sorting, check that the correct sieves have been installed. Change the sieves, see **chapter 8.2.2.**

Sieve recommendations for sorting with a SORTIMAT **K3** (3 sieves):

Product	Fill analysis (nominal hole width in mm)			Remarks
	Top	Middle	Bottom	
Brewing barley	2.8 --	2.5 --	2.2 --	Sieves for determining the boldness!
Malt	2.8 --	2.5 --	2.2 --	Use malt tray!
Barley	3.5 --	2.2 --	1.0 --	Sieve set only for fill analysis!
Wheat	3.5 --	2.0 --	1.0 --	
Rye	3.5 --	1.8 --	1.0 --	
Rape	3.0 (2.8) o	1.8 (2.0) o	1.0 --	2.0 o is better than 1.8 o
Peas	8.0 o	6.5 (6.0) o	3.0 o	
Beans	8.0 o	6.5 (6.0) o	3.0 o	
Horse beans	-	-	-	Sorting not possible!
Maize	9.0 o	6.5 o	4.75 o	
Sunflower seeds	8.0 o	5.5 o	4.75 o	

Sieve recommendations for sorting with a SORTIMAT **K4** (4 sieves):

Product	Fill analysis (nominal hole width in mm)				Remarks
	Top	2 nd sieve	3 rd sieve	Bottom	
Brewing barley	2.8 --	2.5 --	2.2 --	2.0 --	Sieves for determining the boldness!

Sieve recommendations for sorting with a SORTIMAT **K5** (5 sieves):

Product	Fill analysis (nominal hole width in mm)					Remarks
	Top	2 nd sieve	3 rd sieve	4 th sieve	Bottom	
Brewing barley	2.8 --	2.5 --	2.2 --	2.0 --	1.8 --	Sieves for determining the boldness!

Legend:

o = Round hole	-- = Slot hole
----------------	----------------



A dummy sieve (sheet without perforations) can be used for grouping fractions together, for example.

You can obtain the various sieves from Pfeuffer GmbH. See **chapter 11** for available sieves.

7.4 Weighing out the sample

- ⇒ Take a representative sample, see note in **chapter 7.2**.
- ⇒ Mix it well.
- ⇒ Divide up the sample in a sample divider (e. g. Pfeuffer riffle sample divider EBC)
- ⇒ Weigh out **100 g** of the sample on a laboratory balance with an accuracy of 0.1 g. This means you can immediately specify the constituents of the sample in percent when weighing back the individual fractions.
If you are using a balance with a percentage program, it will be sufficient to make an approximate weighing of 100 g.

7.5 Filling the sample



Item	Designation
1	Cover, opened
2	Filling the sample
3	Slide, closed

Figure 7: Filling the sample

- ⇒ Check whether the slide is closed at the side.
- ⇒ Open the cover.
- ⇒ Shake out the sample onto the uppermost sieve.
- ⇒ Close the cover.

7.6 Using broken and round grain separating device (option)

The separating devices are provided with milled recesses, and they sort round and broken grains out of the sample. The separating devices are inserted into the filler opening and are locked with a clamping bracket. The feed speed can be controlled using a guide plate.



Two different separating devices are available from Pfeuffer GmbH:

- Rye and barley
- Wheat

Item numbers see **chapter 11**.

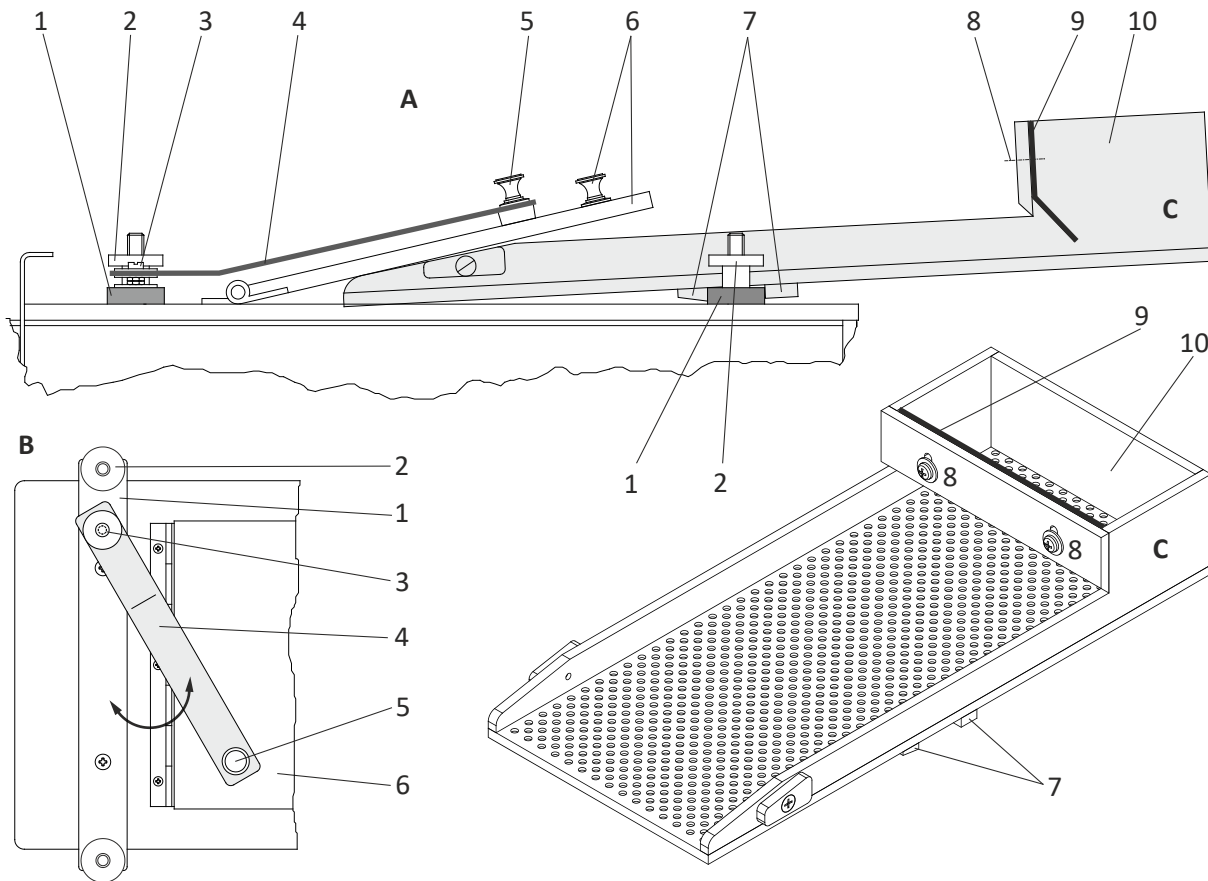

Figure 8: Inserting selecting device

Item	Designation	Item	Designation
A	SORTIMAT side view	5	Brass knob on holding bracket
B	SORTIMAT top view	6	Cover with brass knob
C	Selecting device for wheat	7	Cross strips
1	Holding strip	8	Pan head screws with cross slit for adjusting the guide plate
2	Holding screw with knurled nut	9	Guide plate
3	Holding bracket screw fitting	10	Filling chamber
4	Clamping bracket		

- ⇒ Remove the built-in screw connection (no. 3) on the holding strip.
- ⇒ Attach the clamping bracket to the holding strip using the supplied screw, washers and nuts, as shown in the figure above.
- ⇒ Open the cover (no. 6).
- ⇒ Insert the selecting device into the opening in the cover. The cross strips (no. 7) must engage.
- ⇒ Please the cover on the selecting device.
- ⇒ Turn the clamping bracket via the brass knob on the cover. The spring effect of the holding bracket holds the selecting device via the cover.
- ⇒ Fill the sample into the filling chamber (no. 10) of the selecting device.
- ⇒ Switch the SORTIMAT on using the main switch.
- ⇒ Press the START key.
- ⇒ When all of the sample has run out of the selecting device, switch the device off using the main switch.
- ⇒ Remove the selecting device and close the cover.

- ⇒ Broken and round grains remain in the recesses of the selecting device. Empty the selecting device into a large collecting tray.
- ⇒ Use the cleaning brush supplied with the product to remove grains that are stuck in the recesses.

7.7 Switching the SORTIMAT on and off

- ⇒ Remove the drawer with the collecting trays before the start of sorting.
- ⇒ Set the required sorting time (1-9 minutes) using the coding switch. The standard sorting time is three minutes. See **chapter 7.1** for a description of the control elements.
- ⇒ Switch the SORTIMAT on using the main switch. The "On" LED lights up.
- ⇒ Press the start key. The "On" LED goes out and the "Operation" LED lights up. The SORTIMAT switches off automatically after the set sorting time.
- ⇒ Switch the SORTIMAT off using the main switch.

7.8 Emptying the sample

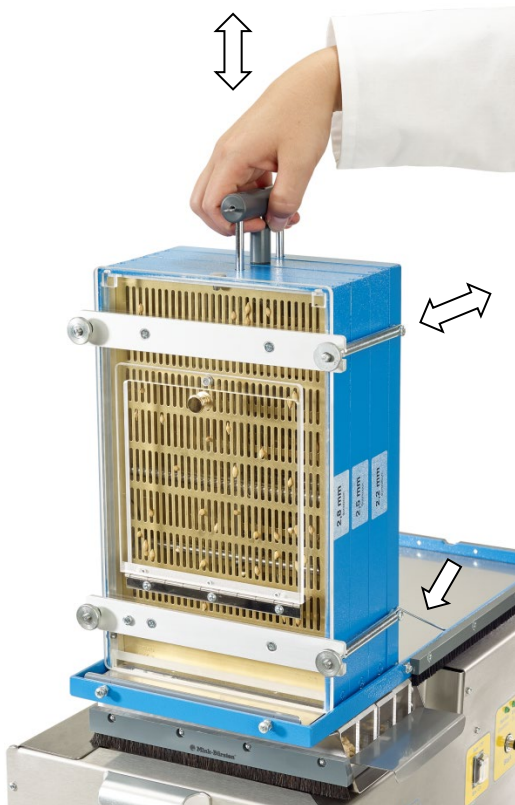

Figure 9: Tipped sieve stack

- ⇒ Pull the pull handle of the sieve cleaning device upward as far as the stop and then press it back down again.
- ⇒ Repeat this procedure 2 or 3 times.
- ⇒ Press the safety spring down and swivel the sieve stack back to its initial position.
- ⇒ Close the slide.
- ⇒ Remove the drawer with the individual collecting trays.

- ⇒ Push the drawer with the collecting trays on the left next to the sieve stack into the drawer cabinet. When sorting malt, use the collecting tray for malt, see **chapter 11** for item number.

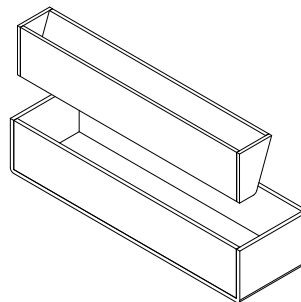

Figure 10: Collecting tray for malt

- ⇒ Lift the sieve stack through 90° using the pull handle of the sieve cleaning device. The safety spring engages.
- ⇒ Pull out the slide as far as the stop. The individual fractions drop directly into the corresponding collecting trays.

7.9 Weighing fractions



⇒ Weigh the content of the collecting trays.

Figure 11: Drawer with collecting trays

7.10 Correction table

The moisture content of the samples has an effect when sorting cereals. Pfeuffer GmbH has conducted internal investigations and produced the following correction table for brewing barley.

All information is subject to change!

Moisture in %	Multiplier*
10.5	0.68
11.0	0.72
11.5	0.77
12.0	0.82
12.5	0.86
13.0	0.90
13.5	0.94
14.0	0.97
14.5	1.00
15.0	1.02
15.5	1.05
16.0	1.08
16.5	1.11
17.0	1.14
17.5	1.18
18.0	1.21
18.5	1.25
19.0	1.28
19.5	1.31
20.0	1.34
20.5	1.38
21.0	1.42
21.5	1.46
22.0	1.50

Examples for using the correction table

1. The amount that falls through the 2.5 mm sieve is 10 %. The moisture of the sample is 19 %. According to the correction table, the value obtained (10 %) must be multiplied by the factor 1.28:
 $10.0 \times 1.28 = \underline{12.8 \%}$
2. With a moisture content of 13 %, the amount that falls through the 2.5 and 2.2 mm sieves is 12.4 %. The multiplier is 0.90; i. e. $12.4 \times 0.90 = \underline{11.16 \%}$ in relation to 14.5 % moisture.
3. When the grain is delivered at harvest time, sorting results in a value of 9.8 % dockage. The moisture content of the sample in question is 22 %. When the barley is dried to 14.5 % moisture content, the grains shrink in volume and the dockage is 14.7 % instead of 9.8 %.

* Multiplier for the fractions that have fallen through the 2.5 mm sorting sieve (= feed barley).

8 Maintenance and cleaning



The Maintenance and cleaning chapter is only intended for **specialist operators**.

NOTICE

Opening the housing and inappropriate operation will invalidate the warranty.

To ensure trouble-free operation, it is essential for the SORTIMAT to be cleaned and maintained at regular intervals.



DANGER

Touching live parts can be fatal!



It is essential to comply with the switch-off procedure before cleaning, maintenance or repair work! (See **chapter 2.9**)

⇒ During all work that is required, wear personal protective equipment according to the company health and safety regulations.

⇒ Pay attention to local statutory accident prevention regulations!



The times for carrying out cleaning and maintenance work are based on one-shift working (8 hour/day, 22 days/month, 12 months/year).

- d** = daily
- w** = weekly
- m** = monthly
- ar** = as required
- $\frac{1}{4} \mathbf{y}$ = every three months
- $\frac{1}{2} \mathbf{y}$ = every six months
- y** = every year

NOTICE

The operating company must provide hazard and disposal information.

NOTICE

Following cleaning, maintenance or exchanging wearing parts, check that all safety devices are functioning correctly.

8.1 Cleaning

NOTICE

Do not use any sharp objects or tools for cleaning. Only use objects that are expressly intended for this purpose.

During cleaning, make sure that no water, steam or dust can penetrate the electronics area.

Cleaning	Rectification	Interval
Housing surface	With a clean, dry and lint-free cloth. Clean with a damp cloth in case of heavy contamination.	w

Cleaning	Rectification	Interval
Sieve cleaning device	Dismantle the sieve stack and check the rubber rollers of the sieve cleaning device for contamination. Clean the rubber rollers with a damp cloth. If necessary, oil the moving parts with a small drop of precision mechanism oil or silicone spray.	m
Sieves	Check the sieves for contamination and stuck grains. Clean the sieves with the cleaning brush, a soft hand brush or compressed air.	m



Pfeuffer GmbH recommends that the SORTIMAT should be given a complete clean before a lengthy period without use (e.g. at the end of the harvest) so as to ensure the machine will continue to remain ready to use.

8.2 Maintenance

Maintenance is a part of servicing and refers to the scheduled cleaning, checking and replacement of wearing parts. The aim of maintenance is to maintain the full functionality of the instrument over its lifetime.

The SORTIMAT should therefore be checked for wear and tear at regular intervals. The inspection intervals depend on the frequency of use and the ambient conditions to which the SORTIMAT is exposed. Only through regular checks (visual inspection) can damage to the instrument caused during use be detected early and reliably.

If you are unsure whether your device is still completely ready for use, Pfeuffer GmbH's professional service team will be pleased to assist you.

8.2.1 Lifting off the sieve stack

⇒ Unscrew the two hexagon nuts (8 mm) and grub screws (2.5 mm hexagon socket) on the carrier frame and lift off the sieve stack.

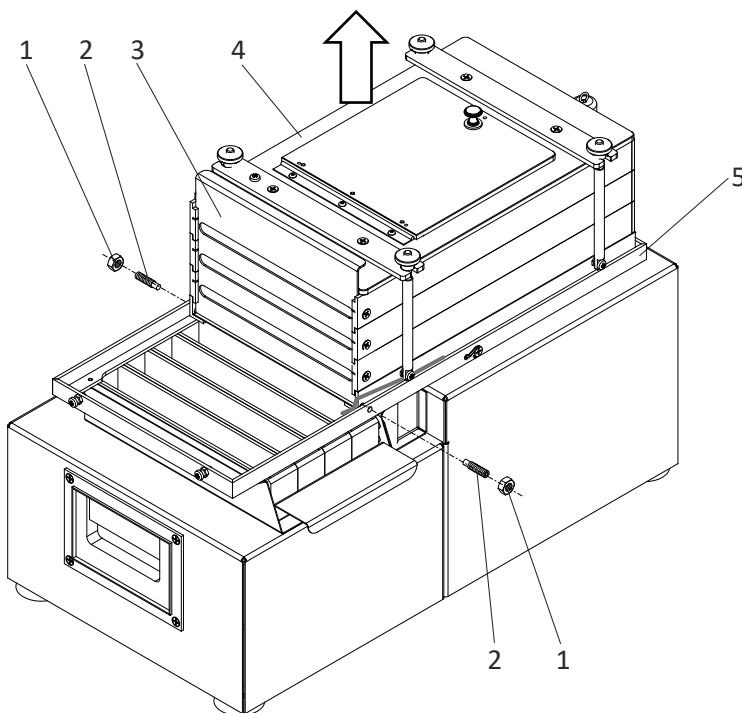

Item	Designation
1	Hexagon nut
2	Grub screw
3	Slide
4	Sieve stack, complete
5	Carrier frame

Figure 12: Lifting off the sieve stack

8.2.2 Replacing sieves



It is only necessary to change the sieves if you want to sort a different product.
See **chapter 11** for available sieves.

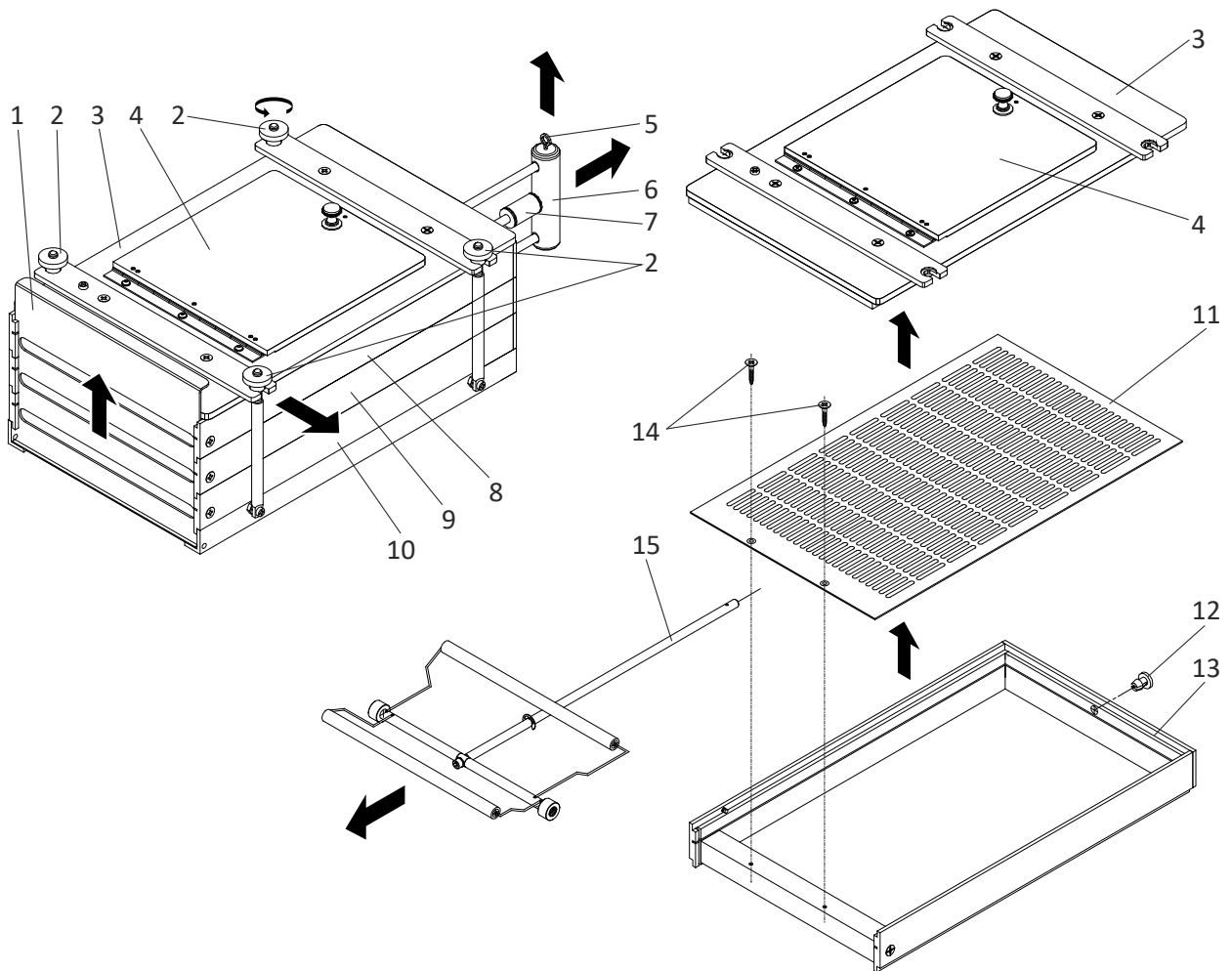

Figure 13: Sieve stack, complete

Item	Designation
1	Slide
2	Holding screw with knurled nut
3	Plexiglas cover
4	Filling cover
5	Securing hook
6	Pull handle
7	Stop (spacer)
8	Upper sieve frame (with barley 2.8 mm slit hole)
9	2nd sieve frame (with barley 2.5 mm slit hole)
10	3rd sieve frame (with barley 2.2 mm slit hole)
11	Sieve
12	Sealing plug (to be installed in uppermost sieve frame)
13	Sieve frame
14	Self-tapping screw
15	Sieve cleaning device, complete

- ⇒ Remove the slide (no. 1) on the sieve stack.
- ⇒ Pull the sieve cleaning device half way out with the pull handle (no. 6).
- ⇒ There is a securing hook on the pull handle of the sieve cleaning device (no. 5). Grip this by the eye and pull it up and out.
- ⇒ Pull the pull handle down at the side.
- ⇒ Remove the spacer (no. 7) and the two cushioning disks.
- ⇒ Unscrew the four knurled nuts on the holding screws (no. 2) evenly and disengage them.

NOTICE

The sieve stack is connected and clamped by the four holding screws. When you unscrew the holding screws, the spring brackets of the sieve cleaning device are slackened.

To prevent the sieve frames from falling out, press the sieve stack down before you disengage the holding screws.

- ⇒ Remove the Plexiglas cover (no. 3).
- ⇒ Remove the uppermost sieve frame. After that, the other sieve frames can be removed.
- ⇒ Pull out the sieve cleaning device (no. 15) to the left in the sieve frame.
- ⇒ The sieves (no. 11) are firmly connected to the sieve frame using two Phillips head countersinking screws (no. 14). Unscrew these two screws on the sieve frame.
- ⇒ Remove the sieve.
- ⇒ Insert the new sieve into the sieve frame with the smooth side and the embossed number facing upwards.
- ⇒ Screw the sieve on tightly with the two Phillips head countersinking screws.
- ⇒ The new sieves are inserted in the two other sieve frames in the same sequence.
- ⇒ Reinstall the sieve cleaning device into each sieve frame.
- ⇒ Place the sieves and the Plexiglas cover back onto one another correctly. Make sure that the sieve with the largest nominal hole width is at the top.
- ⇒ Press the entire stack down and engage the holding screws with the knurled nuts.
- ⇒ Tighten the knurled nuts firmly and evenly.
- ⇒ Close the opening in the uppermost sieve frame for the sieve cleaning device with a sealing plug (no. 12).
- ⇒ Push the spacer with the two cushioning disks over the middle sieve cleaning device and secure everything together with the pull handle over the securing hook.
- ⇒ Insert the slide. The angled piece must point to the right (toward the sieve stack).

NOTICE

To prevent damage, handle the sieves and sieve frames with care. Pfeuffer GmbH recommends cleaning the sieve cleaning device and the sieves every time they are changed, see **chapter 8.1**.



On the YouTube® channel of Pfeuffer GmbH, there is a film showing the change of sieves on the SORTIMAT:

<https://www.youtube.com/user/PfeufferCOM>



8.2.3 Exchanging the spring brackets on the sieve cleaning device



It is only necessary to change the spring brackets if they are broken. Indication of this are given in **chapter 9**.

⇒ Dismantle the sieve stack as described in **chapter 8.2.2**.

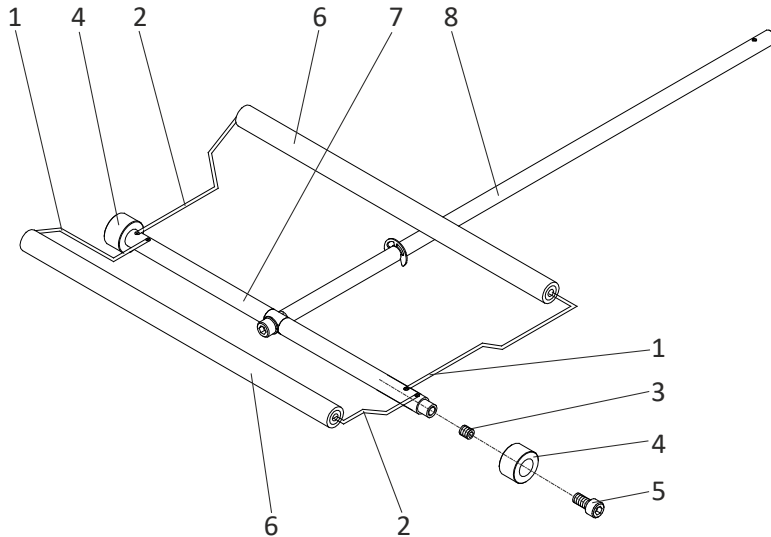

Figure 14: Sieve cleaning device, complete

Item	Designation	Item no.:	Item	Designation	Item no.:
1	Spring bracket, inner	3125 0060	5	Allen screw	
2	Spring bracket, outer	3125 0065	6	Rubber roller	2440 0172
3	Grub screw		7	Shaft	
4	Wheel	3121 0020	8	Push rod	

Outer spring bracket

- ⇒ Unscrew the Allen screw (2.5 mm) on the wheel (approx. 1 turn).
- ⇒ Pull the old spring bracket out of the shaft and the rubber roller.
- ⇒ Insert the new spring bracket.
- ⇒ Tighten the Allen screw firmly again.

Inner spring bracket

- ⇒ Unscrew and remove the Allen screw (2.5 mm) and the wheel.
- ⇒ Unscrew the grub screw with hexagon socket (2 mm) behind that (approx. 1 rotation).
- ⇒ Pull the old spring bracket out of the shaft and the rubber roller.
- ⇒ Insert the new spring bracket.
- ⇒ Tighten the grub screw firmly again.
- ⇒ Push on the wheel.
- ⇒ Tighten the Allen screw firmly again.



Also renew the rubber rollers and the wheel if they are severely worn. Item numbers see **chapter 9.1**.

If necessary, oil the moving parts with a small drop of precision mechanism oil or silicone spray.

8.3 Inspection interval and function test

Sub-assembly	Interval in one-shift working				
	w	m	¼ y	½ y	y
Normal function tests:					
Main switch On/Off		X			
Mains cable and connection					X
Check the correctness and firm fit of the entire machine			X		
Check all cables for damage and aging				X	
Check protective covers for defects, as well as for correct and tight fit		X			
Check all plug-in, screw-in and clamp connections for firm fit, tighten if necessary			X		
Electrical test according to VDE	See DGUV regulation 3				

DANGER



Damaged cables increase the risk of getting an electric shock!



- ⇒ Never touch a damaged cable (e.g. cable that has been cut into, insulation damaged etc.)
- ⇒ Disconnect the cable from the electrical power supply immediately.
- ⇒ Replace the cable with a new one.

NOTICE

Removable mains cables must not be replaced by inadequately dimensioned mains cables. Only the specified mains cables may be used!

9 Malfunctions – causes and rectification



The information provided in this chapter about possible malfunctions is structured to be understood by specialists in electrical, electronic or mechanical maintenance. Appropriate tools and test instruments must be provided to these personnel. If the specified measures do not prove successful, contact Pfeuffer GmbH. It is important for all questions to specify the correct type designation, serial number and year of manufacture. Only in this way will rapid processing be possible. The information can be found on the type plate.



DANGER

Touching live parts can be fatal!



It is essential to comply with the switch-off procedure before cleaning, maintenance or repair work! (See **chapter 2.9**)

Problem	Cause	Rectification
The SORTIMAT does not function at all.	No mains voltage.	Have the mains voltage checked by an electrician and switched on.
	Main switch ON/OFF is in position OFF.	Switch the main switch to the ON position.
	Internal fuse in the mains switch defective.	Test and replacement by an electrician , see chapter 9.1 .
The green LED does not light up after switch-on.	Internal fuse in the mains switch defective.	Test and replacement by an electrician , see chapter 9.1 .
	The mains cable is not firmly connected.	Check all plugs are firmly seated.
The SORTIMAT does not start up after the start key is pressed.	Defective timer	Test and replacement by an electrician or Pfeuffer GmbH.
	Defective motor	Test and replacement by Pfeuffer GmbH.
The SORTIMAT stops working during the investigation.	Defective timer	Test and replacement by an electrician or Pfeuffer GmbH.
	Defective motor	Test and replacement by Pfeuffer GmbH.
The motor starts but the sieve stack does not move.	The V-belt has slipped off or is torn.	Attachment or renewal by a specialist or Pfeuffer GmbH.
The sieve stack does not move smoothly.	The support springs are bent.	Test and replacement by an electrician or Pfeuffer GmbH.
Unusual, periodic noise during sorting	The springs have been screwed on in tensioned condition.	Have the connecting rod or support springs checked by a specialist or Pfeuffer GmbH.
Cereal falls out the side after starting.	The slide is open.	Close the slide.
Cereal falls out on the right at the uppermost sieve after starting.	The sealing plug is missing (see figure in chapter 8.2.2).	Insert the sealing plug.
The drawer rattles during operation.	The drawer is in the device during operation.	The drawer should not be in the device during operation. Only insert the drawer after the sorting has finished.
The SORTIMAT does not stay in one place on the base during operation.	The suction feet are contaminated or damaged.	Clean or exchange the suction feet, see chapter 9.1 for item numbers.
The sieve cleaning device has jammed.	A spring bracket is broken.	Dismantle the sieve stack and exchange the damaged spring brackets, see chapter 8.2.3
	The sieve cleaning device is contaminated.	Dismantle the sieve stack, clean the sieve cleaning device, see chapters 8.2.3 and 8.1 . If necessary, oil the moving parts with a small drop of precision mechanism oil or silicone spray.

Problem	Cause	Rectification
The drawer overflows.	Too much sample filled. Sorting malt (a large proportion of the grains are larger than 2.8 mm) The sequence of sieves is incorrect.	Repeat the sorting with 100 g of sample. Use the collecting tray for malt which is available as an accessory, see chapter 11 for item number. Check the installation sequence of the sieves is correct.
The sorting results are unsatisfactory.	The sequence of sieves is incorrect. Contaminated product filled. The nominal hole widths of the sieves are incorrect.	Check the installation sequence of the sieves is correct. Clean the product before sorting, e.g. using a Pfeuffer sample cleaner. Check the selection of sieves, see chapter 7.3 or Check the nominal hole widths with a nozzle gage, see chapter 14 .

9.1 Renewing the internal fuse

Below the IEC power connector on the back of the device there is a plug connection, see figure 15. An internal glass microfuse (1 A, slow-blow, 5x20 mm) is incorporated in this.

NOTICE

Always refer to the type plate for the precise fuse rating!

DANGER



Touching live parts can be fatal!



It is essential to comply with the switch-off procedure before cleaning, maintenance or repair work! (See **chapter 2.9**)

⇒ Switch off the SORTIMAT using the main switch and disconnect the mains plug from the electrical power supply.



Figure 15: Renewal of the internal fuse

- ⇒ Pull out the plug connection under the IEC power connector.
- ⇒ Renew the glass microfuse. Item number see **chapter 9.1**.
- ⇒ Push the plug connection back into the IEC power connector.
- ⇒ The SORTIMAT is ready for operation.

10 Spare and wearing parts

NOTICE

We wish to point out expressly that replacement and accessory parts not supplied by us will not have been tested and approved by us either. Installing and/or using such products can thus result in the design properties of the SORTIMAT being negatively impaired.

Pfeuffer GmbH cannot be held liable for damage attributable to the use of non-genuine parts and non-genuine accessories.

Standard parts can be obtained from the dealer.

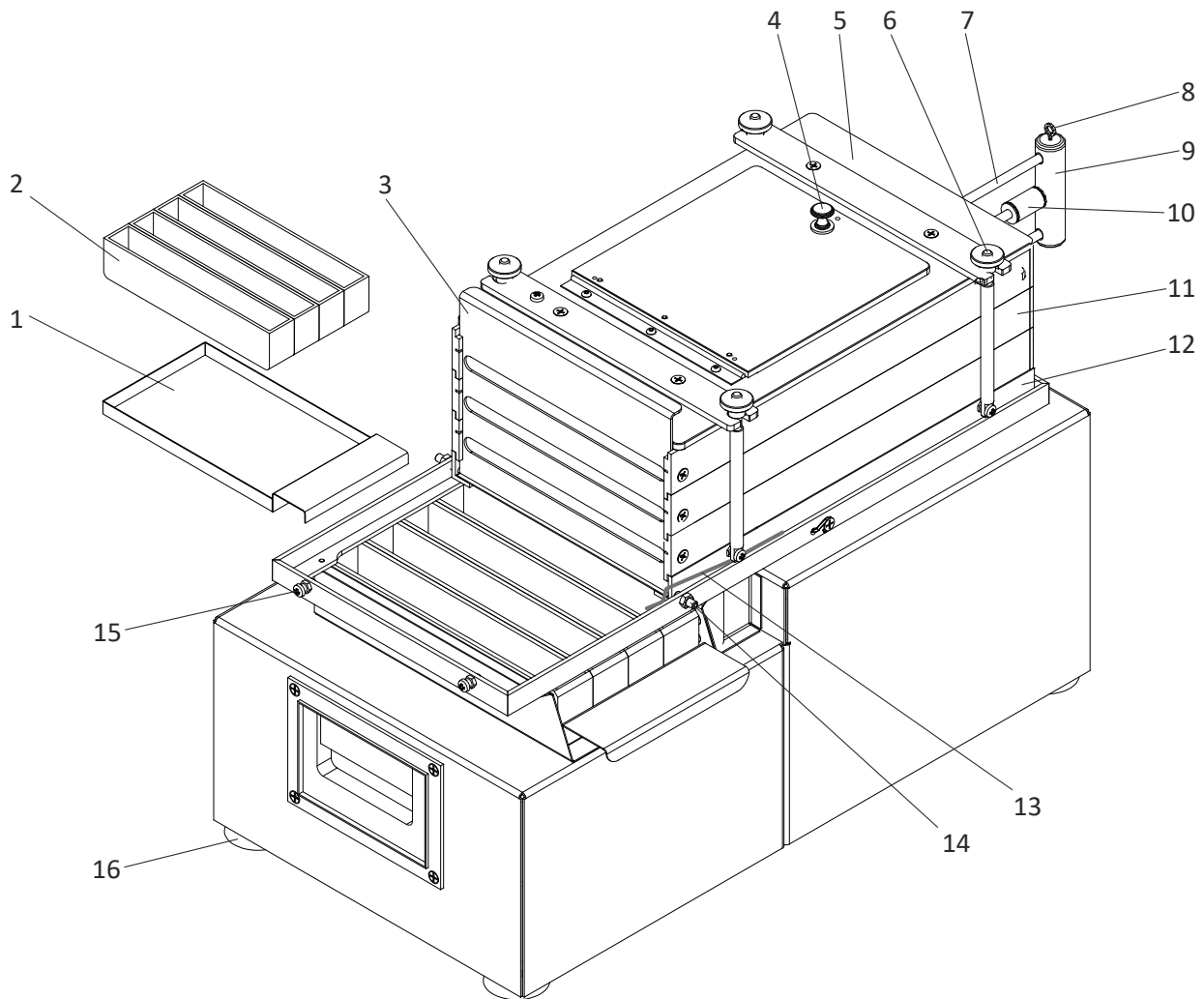

Figure 16: SORTIMAT spare parts

Item	Spare part	Item no.
1	Drawer K3	3111 0004
	Drawer K4	3111 0104
	Drawer K5	3111 0204
2	Collecting tray (K3 = 4x, K4 = 5x, K5 = 6x)	2440 0019
not illustr.	Collecting tray for malt	2440 0022
3	Slide K3	3111 0007
	Slide K4	3111 0107
	Slide K5	3111 0207
4	Brass knob	3134 0001
5	Cover, complete	2440 0160

Item	Spare part	Item no.
6	Holding screw K3, complete	2440 0145
	Holding screw K4, complete	2440 0146
	Holding screw K5, complete	2440 0147
7	Sieve cleaning device, complete (detailed illustr. see chapter 8.2.3)	2440 0170
	Spring bracket, outer	3125 0065
	Spring bracket, inner	3125 0060
	Rubber roller	2440 0172
	Wheel	3121 0020
8	Securing hook K3	3125 0040
	Securing hook K4	3125 0041
	Securing hook K5	3125 0042
9	Pull handle K3	3160 2400
	Pull handle K4	3160 2402
	Pull handle K5	3160 2404
10	Stop (spacer) (K3 = 1x, K4 + K5 = 2x)	3160 2401
	Cushioning disk (K3 = 2x, K4 + K5 = 4x)	3135 2400
11	Sieve frame, complete	2440 0150
12	Tilting frame, complete	2440 0150
13	Spring for locking unit	3125 2010
	+ fillister head screw M3	3100 2025
	+ plain washer M3	3102 1003
14	Grub screw M5 (K3, K4)	3170 2474
	+ hexagon nut M5	3101 0015
	Grub screw M5 (K5)	3170 2475
	+ hexagon nut M5	3101 0015
15	Calibrating screw (fillister head screw) M4	3100 2060
	+ hexagon nut M4	3101 0010
16	Suction foot	3135 0010
not illustr.	Glass microfuse 1 A slow-blow, 5 x 20 mm (10x)	3253 0216
not illustr.	Support springs, 1 set	3125 0051
not illustr.	Timer, complete	2440 0310

NOTICE

Repair and renewal work on the **motor** should only be carried out by a **specialist!**

Please contact Pfeuffer GmbH if you have any questions.

11 Supplements and accessories

Product	Item no.
Broken and round grain separating device for wheat	2440 0021
Broken and round grain separating device for barley and rye	2440 0020
Clamping bracket for separating device	3175 2410
Collecting tray for separating device	3110 2410
Collecting tray for malt	2440 0022
Nozzle gage (hole gage) for checking the nominal hole widths	1249 0020
Riffle sample divider EBC (different models available)	On request

Analysis sieves (brass or sheet steel)

Available sieve sizes:	Nominal hole width in mm:				
Slot/slit perforation	1.0	2.0	3.0	4.0	
	1.2	2.1	3.25		
	1.25	2.2	3.3		
	1.3	2.25	3.5		
	1.4	2.3			
	1.5	2.4			
	1.8	2.5			
	1.9	2.6			
		2.75			
		2.8			
Round hole	1.0	2.0	3.0	4.0	5.25
	1.4	2.45	3.15	4.25	5.5
	1.5	2.5	3.25	4.5	
	1.7		3.65	4.75	
	1.8				
Dummy sieve (sheet without perforations)					

12 Emergency



⇒ In an emergency, disconnect the SORTIMAT from the electrical power supply.

13 Dismantling and disposal



Dismantling and disposal is only allowed to be carried out by **specialist personnel**.



DANGER

Touching live parts can be fatal!



It is essential to comply with the switch-off procedure before cleaning, maintenance or repair work! (See **chapter 2.9**)



Special waste

Oil, cleaning agents, contaminated cleaning tools (brush, rags, etc.) must be disposed of according to the local regulations and in accordance with the notes in the manufacturers' safety data sheets.



Disposal with the household garbage is forbidden!

The SORTIMAT must be disposed of in accordance with the applicable local environmental regulations (Waste Electrical and Electronic Equipment Directive WEEE 2012/19/EU).

14 DIN ISO 9001 – documentation

In practical applications, the introduction of QM and TQM systems is becoming increasingly important. Here you can find some points indicating how the accuracy of your test instrument can be documented.

Test certificate

If you sent the device to the factory, you can pay for a quality test certificate to be issued.

Comparison sample

The simplest test for checking the test status is to perform a sorting procedure with a reference sample.

Monitoring intervals for test instruments

It is recommended for the parameters stated below to be checked and documented once a year. Here is a suggestion for a form that should make this task easier.

Checking the nominal hole widths:

A certified precision nozzle gage with a read-off accuracy of 1/100 mm is available for accurate measurement of the nominal hole widths, see **chapter 11** for item number.

Tolerances for sieve plates:

Slot: ISO 5223 Test sieves for cereals
 Round hole: DIN ISO 3310-2 Test sieves – Technical requirements and testing – Part 2: Test sieves of perforated metal plate

Test process

	1	2	3	4	5	6	7	8	9	10	11	12	13	14	15	16	17	18	19	20	21	22	23	24	25	26	27	28	29	
1																														
2																														
3																														
4																														
5																														
6																														
7																														
8																														
9																														
10																														
11																														

Figure 17: Diagram for selecting the hole widths to be tested

- ⇒ Select about 40 sieve holes (see diagram for 2.5 mm sieve with 29 x 11 holes, 44 selected).
- ⇒ Position the sieve plate vertically and clamp it in the clamping fixture.
- ⇒ Insert the measuring tip of the nozzle gage manually at an angle of 90° into the sieve hole (the gage must be at right angles to the sieve). Advance it until you encounter resistance, but without applying force, hold firmly at the top end, the vernier scale moves down.
- ⇒ Read off the result on the vernier directly in the inserted condition. Enter it in a test log (see master copy in **chapter 14.1**).

NOTICE

The results can be falsified by removing the nozzle gage before reading off the result, e.g. due to the measuring tip jamming or having a pushing force exerted on it!

- ⇒ The sieve should be discarded if the nominal hole with is outside the tolerance required in the standard for more than 3 values. Please contact the manufacturer!

Checking the sorting time:

There is no need to measure and check the preset sorting time. The influence of this parameter can be regarded as slight. Please contact the factory if the preset sorting time differs by more than ten seconds. The discrepancy can be greater in devices of an older design (year of manufacture before 1991). However, it must not be more than one minute.

14.1 Test log for nominal hole widths

This log is intended to allow the owner-operator to document the test status of the SORTIMAT laboratory sorting machine.

Company, location _____
 SORTIMAT type: _____
 Year of manufacture: _____
 Serial number: _____

Company stamp:

Checking the nominal hole widths

Nominal hole width – tolerances for sieve plates:

Slot: ISO 5223 Test sieves for cereals
 Round hole: DIN ISO 3310-2 Test sieves – Technical requirements and testing –
 Part 2: Test sieves of perforated metal plate

Nominal hole width as embossed: _____ mm specified tolerance: _____ mm

Actual hole widths:

	1	2	3	4	5	6	7	8	9	10	11	12	13	14	15	16	17	18	19	20	21	22	23	24	25	26	27	28	29
1																													
2																													
3																													
4																													
5																													
6																													
7																													
8																													
9																													
10																													
11																													

The tester confirms that the measurement has been carried out correctly as described in the operating instructions in **chapter 14**.

The nominal hole widths correspond to the actual hole widths: Yes No

The sieve meets the requirements stated in the aforementioned regulations: Yes No

Place, date

Name, position

Signature

14.2 Test log for sorting test

This log is intended to allow the owner-operator to document the test status of the SORTIMAT laboratory sorting machine.

Company, location: _____

SORTIMAT type: _____

Year of manufacture: _____

Serial number: _____

Company stamp:

Test material: _____ (e.g. brewing barley)

Sorting test

Sieve	Hole width in mm	1st test Residue	2nd test Residue	3rd test Residue	Nominal residue	Average value	Difference
1							
2							
3							
4							
5							

The tester confirms that the measurement and sorting has been carried out correctly as described in the operating instructions in **chapter 7** (Operation).

The SORTIMAT meets the requirements placed on it:

Yes No

Place, date

Name, position

Signature