

UNIMOTION

CTL

LINEAR UNIT WITH
A LINEAR MOTOR



GERMAN
DESIGN
AWARD
WINNER
2022



About Us

UNIMOTION is a leading company in the industrial automation field, at a global level. Combining innovative engineering solutions – Unimotion helps companies of all sizes across a wide range of industrial segments. Unimotion develops Industry 4.0-enabled products and systems with leading quality, performance and value. Engineering, Production, Construction, Warehouse, Research & Development department; all this can be found under one roof. Thanks to years of experience and a consistent focus on automation technology, we are continually improving our products and implementing innovations that provide customers with many technical advantages. Our core values are precision, innovation, passion, and integrity. At Unimotion, our main goal is the satisfaction of every single customer with a commitment to deliver the impossible.

Unimotion sales team, technicians and experts are at your disposal to provide customized expertise and support. We look forward to meeting you and work on your special project.

Follow UNIMOTION on different social platforms and subscribe to our latest news



Table of Contents

Linear unit – CTL	4
Characteristics	5
Structural design	6
How to order	7
Technical data	8
Dimensions	14
Accessories	19
Electrical data	20
Linear motors	21
CTL connectors	21
Measuring systems	22
Drive-motor cables	22
IIoT module	22
Hall sensor	22
Accessories	23
Clamping fixtures	24
Connection elements	25
Connection plates	26
Magnetic field sensor	27
Energy chain	28
Drive-motor cables	29
Service life	31
Linear guiding	32
Links	34

Linear unit – CTL

Characteristics	5
Structural design	6
How to order	7
Technical data	8
Dimensions	14
Accessories	19

CHARACTERISTICS

CTL is a linear unit with an integrated high-performance UNIMOTION linear motor. High accuracy is achieved using a precision low noise linear guiding system while the linear motor enables extremely high dynamic movements.

Using innovative UNIMOTION linear motor drive enables the unit to achieve speeds up to 5 m/s and offer the highest acceleration among all of our linear units.

Due to the linear motor drive, the CTL linear units are backlash-free.

The CTL linear units offer a range of different built-in incremental and absolute measurement systems.

The combination of the linear motor drive and the measurement systems offer a repeatability precision of up to 0,001 mm.

CTL linear units are designed to be as compact as possible with no compromise to high performance. This makes them perfect for a wide range of different applications.

As an option, a standard energy chain can be added to the unit. The standard energy chain is specifically suited to operate in highly dynamic and low noise applications thanks to a special link design.

A corrosion-resistant protection strip shields the inside of the unit from environmental influences such as dirt or particles. The innovative tensioning solution offers perfect alignment of the protection cover even on long strokes and high accelerations

The anodized aluminium profile body has side slots for the clamping fixtures and the magnetic field sensors.

A central lubrication port located on both sides of the carriage enables simple relubrication and provides easy maintenance.

i The aluminium profiles are manufactured according to the EN 12020-2 standard



STRUCTURAL DESIGN

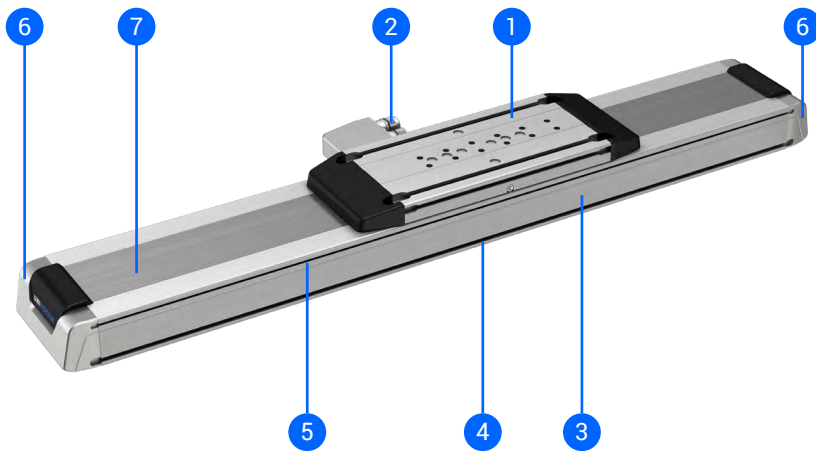

- 1 – Carriage
- 2 – Motor and encoder connectors (IIoT connector optional)
- 3 – Aluminium base profile
- 4 – Slot for mounting
- 5 – Slot for the magnetic field sensors
- 6 – End block with the protection strip tensioning system
- 7 – Corrosion-resistant protection strip

With a preassembled standard energy chain

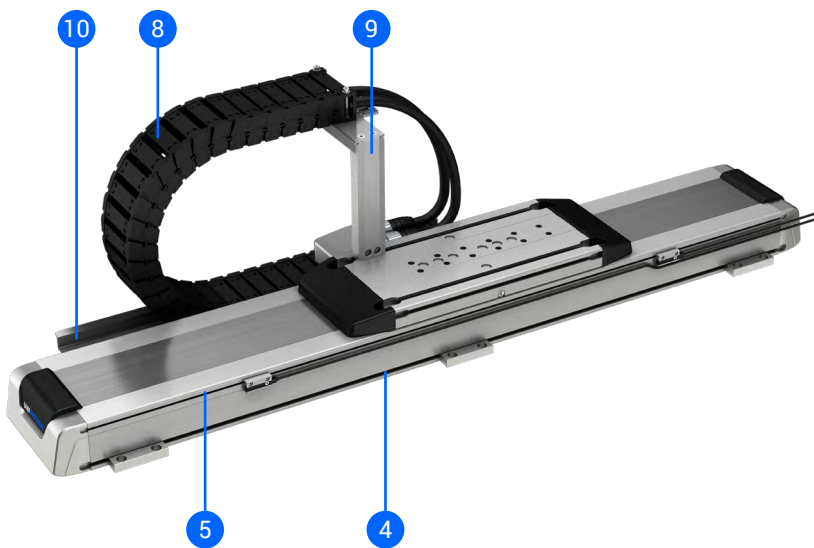

HOW TO ORDER

CTL - **145** - **3000** - **1 S 1 LC** - **10** - **BCCA** - **1** - **B** - **C12** - **0**

Series:
CTL

Size:
- 145
- 200
- 250

Absolute stroke [mm]:
(Absolute stroke = Effective stroke + 2 × Safety stroke)

Number of carriages:
i Up to 5 carriages available

Carriage version:
- S: Short
- L: Long

Protection cover:
- 0: Without
- 1: Corrosion-resistant protection strip

Speed class:
- L: Low speed
- H: High speed

i CTL 145 is available only with a low speed class.

Magnet plates:
- C: Classic
- H: High performance (Available soon)

Connector orientation:
- 1: Backward
- 2: Forward

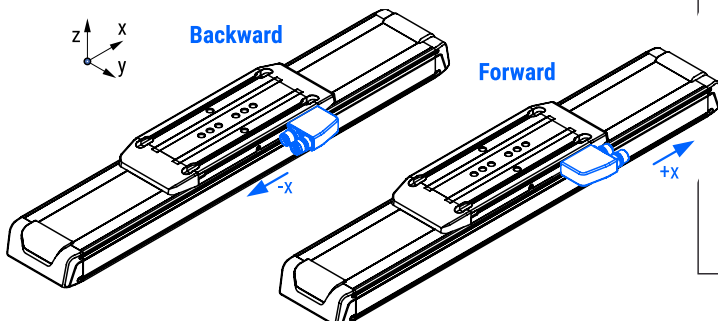

i The linear unit is symmetrical, therefore the placement of the connectors on the other side of the carriage can be achieved by rotating the unit along its Z axis.

Hall sensor:
- 0: Without
- 1: With

i When IIoT connection is selected, Hall sensor is selected automatically. If an absolute measuring system is selected the Hall sensor is not available.

Manufacturer of measuring system:
- A

Resolution:
- A: 0,01
- B: 0,005
- C: 0,000977
- D: Depending on the drive

Communication:
- A: Digital RS422 / TTL 5V
- B: Analog 1 Vpp
- C: Digital BiSS-C

Type	Communication	Resolution [mm]	Max speed	Order code ²
Magnetic incremental	Digital RS422/ TTL 5V	0,005	4,67	AAB
	Digital RS422/ TTL 5V	0,01	9,33	AAA
	Analog 1 Vpp	¹	80	ABD
Magnetic absolute	Digital BiSS-c	0,000977	7	BCC

¹ Resolution is drive dependant

² Order code fields: Measuring system, Communication, Resolution

Measuring system:
- A: Magnetic incremental
- B: Magnetic absolute

i For possible encoder coding combinations please check the table on the right.

IIoT connection:
- 0: Without
- 1: With (Available soon)

CTL - 145 - 3000 - 1 S 1 LC - 10 - BCCA - 1 - B - C 12 - 0

Energy chain:

- 0: Without
- A: 28 × 70
- B: 28 × 100

i Connector orientation also determines the energy chain mounting direction. For more information please refer to the dimensional drawing in the section "Dimensions". For technical information please refer to the section "Accessories → Energy chain".

i Available for absolute stroke of up to 4800 mm. For technical information please refer to the section "Accessories → Energy chain → Technical data"

Cables:

- 0: Without
- A: Power cable only
- B: Signal cable only
- C: Power and signal cable

- Length in meters. Up to 15 m.

Environment:

- 0: normal
- C: cleanroom

i ISO class 3 for speeds up to 250 mm/s, ISO class 5 for speeds up to 1000 mm/s.

i Cleanroom version available only without protection cover, without energy chain and without cables.

TECHNICAL DATA

General technical data

CTL	Carriage version	Dynamic load capacity ¹ C [N]	Dynamic moments ¹			Max. permissible loads					Max. repeatability ² [mm]	Min. stroke ³ [mm]	Max. stroke ⁴ [mm]	Dimensions	
						Forces		Moments						Width ⁵ [mm]	Height ⁶ [mm]
			$M_{dyn x}$ [Nm]	$M_{dyn y}$ [Nm]	$M_{dyn z}$ [Nm]	F_{py} [N]	F_{pz} [N]	M_{px} [Nm]	M_{py} [Nm]	M_{pz} [Nm]					
145	S	45810	2220	3770	3770	9070	8125	450	630	750	up to ±0,001	40	5970	145	85
	L	61080	2960	5970	5970	12090	13070	510	1915	1185		40	5880		
200	S	75050	5140	6730	6730	15410	13105	955	1015	1385		55	5935	200	107
	L	100060	6850	10630	10630	20545	17970	1205	2760	2015		55	5850		
250	S	109160	9600	10600	10600	22390	26605	2570	2590	2175		60	5900	250	119
	L	145550	12800	16930	16930	29855	38845	3635	5665	3475		60	5800		

¹ Dynamic load capacity and dynamic moments of the linear guiding system. These values are the basis for calculating the service life. There should be noted that some pretension of the linear guides due to the attraction force of the linear motor is always present in the guiding system. For more information regarding this pretension, please refer to the section "Service life".

² Depends on the measuring system.

³ For shorter strokes, please contact us.

⁴ For longer strokes, please contact us.

⁵ Max. width of the linear unit without the connectors on the carriage.

⁶ Height of the linear unit from the bottom of the profile to the top of the carriage.

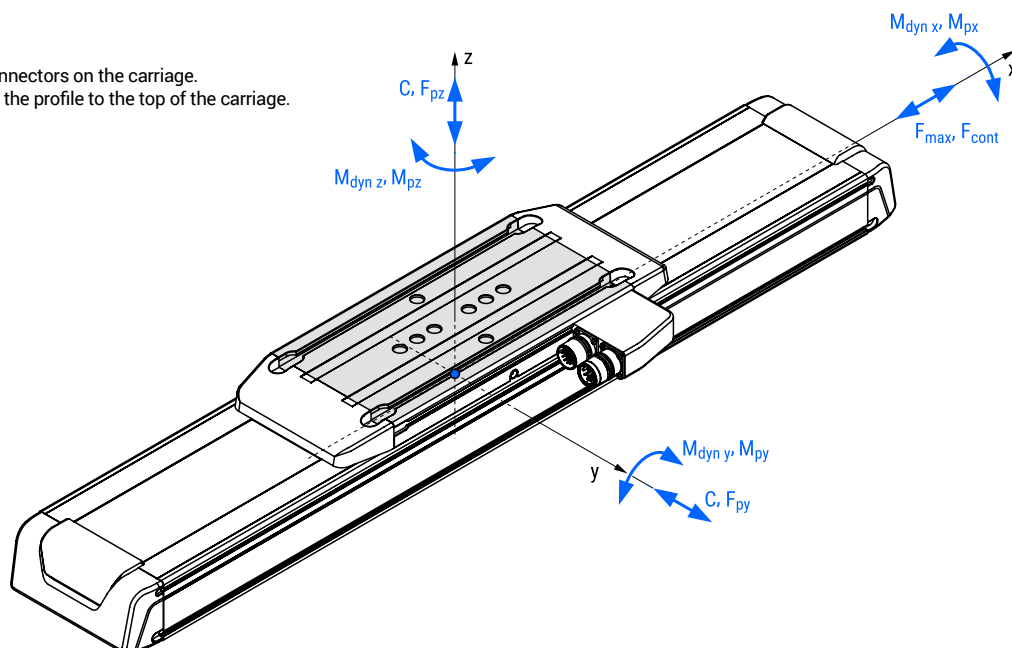

Drive data

CTL	Carriage version	Speed class	Linear motor ¹	Maximum axial load ^{4,5}	Continuous axial load ⁴	Frictional force of the carriage without load	Max. travel speed ³	Max. acceleration ²
				F _{max} [N]	F _{cont} [N]	F ₀ [N]	v _{max} [m/s]	[m/s ²]
145	S	Low speed	LMCA 30 M L	550	250	45	5,0	90
	L	Low speed	LMCA 30 L L	825	375	55	5,0	
200	S	Low speed	LMCA 60 M L	1105	500	65	5,0	
		High speed	LMCA 60 M H					
	L	Low speed	LMCA 60 L L	1650	750	85	5,0	
		High speed	LMCA 60 L H					
250	S	Low speed	LMCA 90 M L	1655	750	85	4,1	
		High speed	LMCA 90 M H				5,0	
	L	Low speed	LMCA 90 L L	2475	1125	105	4,1	
		High speed	LMCA 90 L H				5,0	

¹ In combination with the standard magnetic plate. For more information regarding the linear motors, please refer to the Unimotion documentation related to the linear motors via the links on page 35.

² Maximum acceleration of the linear unit with the protection cover is limited to 50 m/s².
The lower value (the one specified in the table or the limit value stated here) must be considered.

³ Maximum travel speed depends of the supply voltage of the linear motor.

⁴ Maximum and continuous axial loads depend on the travel speed, see the following diagram.

⁵ For a time period of 1 second at 20 °C.

Operating conditions

Ambient temperature	+5 °C ~ +40 °C
Protection class	IP40 ¹
Duty cycle	100 %
Cleanroom class	ISO 3 ²

¹ If the protection strip is used, otherwise IP20 should be considered.

² ISO 3 certified for speeds up to 250 mm/s, ISO 5 certified for speeds up to 1000 mm/s. Cleanroom version of the CTL linear unit is available without protection strip, without energy chain and without cables.

i Recommended values of loads:

All the data of the dynamic load capacities (of the linear guiding system) stated in the tables above are theoretical without considering any safety factor. The safety factor depends on the application and its requested safety and service life.

We recommend a minimum dynamic safety factor of 5,0 or more. Please refer to page 32, where the calculation of the safety factor of the linear guiding system and how the applied load affects the service life are presented.

Pretension of the linear guiding system due to the attraction force of the linear motor is also presented.

Mass of the linear unit

CTL	Carriage version	Moved mass ¹ m _{m, CTL} [kg]	Mass of the linear unit ²							
			With the protection cover				Without the protection cover			
			m _{CTL} [kg]		m _{CTL} [kg]		m _{CTL} [kg]		m _{CTL} [kg]	
145	S	5,50	12,20	+	0,0129	× Abs. stroke	12,03	+	0,0125	× Abs. stroke
	L	7,35	15,30	+	0,0129	× Abs. stroke	15,09	+	0,0125	× Abs. stroke
200	S	9,70	21,95	+	0,0234	× Abs. stroke	21,70	+	0,0230	× Abs. stroke
	L	12,80	27,20	+	0,0234	× Abs. stroke	26,94	+	0,0230	× Abs. stroke
250	S	14,45	31,70	+	0,0323	× Abs. stroke	31,42	+	0,0318	× Abs. stroke
	L	19,25	39,95	+	0,0323	× Abs. stroke	39,58	+	0,0318	× Abs. stroke

¹ The moved mass is already considered in the equation for calculating the mass of the linear unit m_{CTL}. The moved mass includes the mass of the carriage together with the forcer and linear guides. For the option of the linear unit with a standard energy chain, the moved mass m_{m, CTL} should be increased by m_{m, ec}, see the table below.

² Valid for the linear unit without the standard energy chain. For the option of the linear unit with a standard energy chain, the mass m_{CTL} should be increased by m_{ec}, see the table below.

Abs. stroke	Absolute stroke	[mm]
-------------	-----------------	------

Additional mass of the linear unit when the standard energy chain is selected.

CTL	Energy chain size ¹	Mass of the energy chain set ²				Max. moved mass ³			
	$h_{ec} \times w_{ec}$ [mm]	m_{ec} [kg]				$m_{m,ec}$ [kg]			
145	28 × 70	1,40	+	0,00172	× Abs. stroke	1,05	+	0,00060	× Abs. stroke
	28 × 100	1,59	+	0,00198	× Abs. stroke	1,17	+	0,00069	× Abs. stroke
200	28 × 70	1,39	+	0,00183	× Abs. stroke	1,01	+	0,00060	× Abs. stroke
	28 × 100	1,58	+	0,00210	× Abs. stroke	1,13	+	0,00069	× Abs. stroke
250	28 × 70	1,39	+	0,00191	× Abs. stroke	1,00	+	0,00060	× Abs. stroke
	28 × 100	1,58	+	0,00218	× Abs. stroke	1,12	+	0,00069	× Abs. stroke

¹ Internal height and width of the standard energy chain.

² The mass m_{ec} refers to the mass that is added to the mass of the linear unit m_{CTL} if the standard energy chain option is selected.

³ Max. moved mass $m_{m,ec}$ includes the complete mass of the energy chain and its holder. This mass should be added to the moved mass of the linear unit $m_{m,CTL}$ if the standard energy chain is selected.

Abs. stroke Absolute stroke [mm]

i For more information regarding the energy chains, please refer to the section "Accessories → Energy chain".

Planar moment of inertia

CTL	CTL profile	
	I_y [cm ⁴]	I_z [cm ⁴]
145	74,7	620,6
200	184,8	2087,3
250	339,6	4485,2

Deflection of the linear unit as a function of vertical force and unsupported profile length

i In the following diagrams, the deflection of the linear unit as a function of the vertical force and unsupported profile length is presented. For the case, the linear unit is mounted to the bottom of the profile, see the diagrams on the left. For the case, the linear unit is mounted on its side, see the right column of the diagrams.

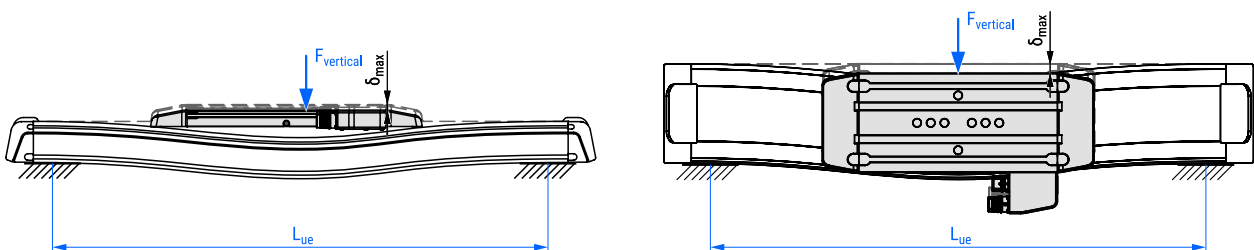

CTL 145

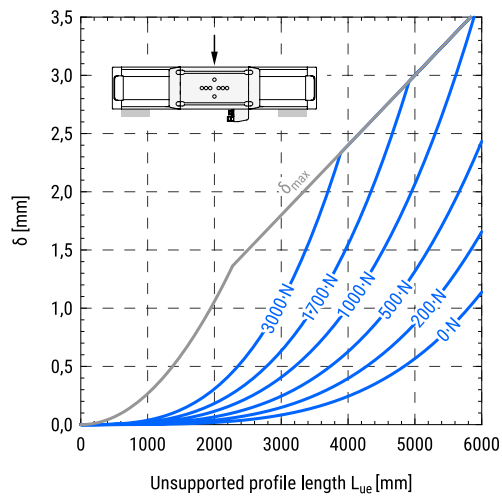
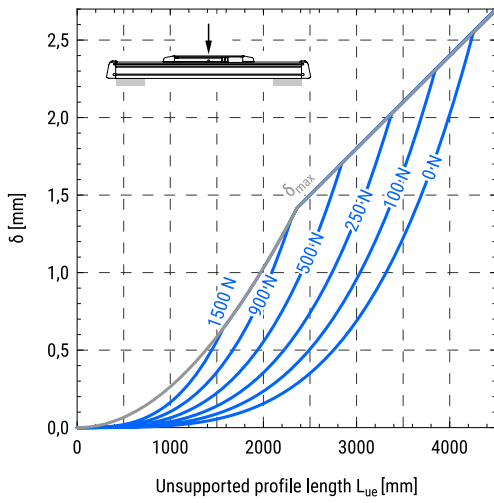

CTL 200

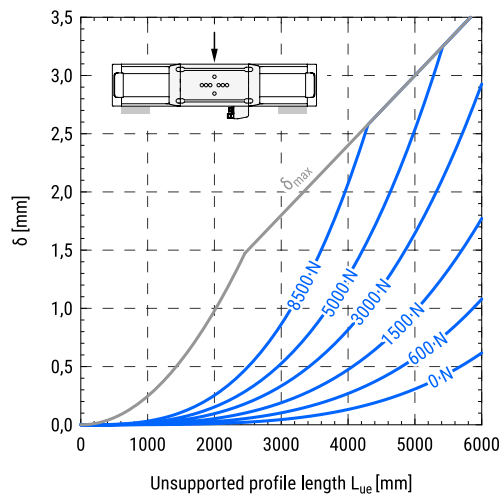
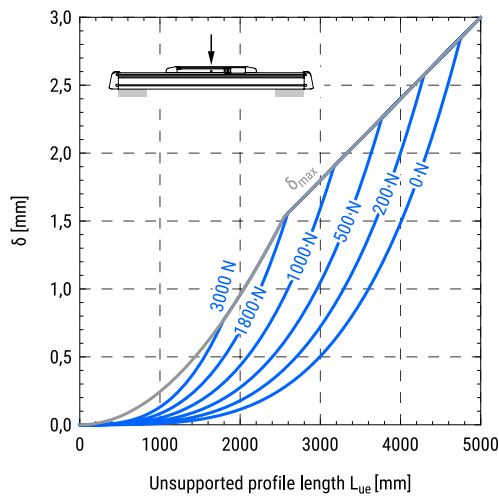

CTL 250

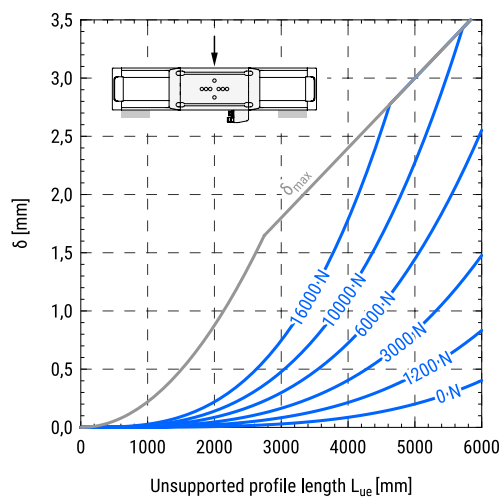
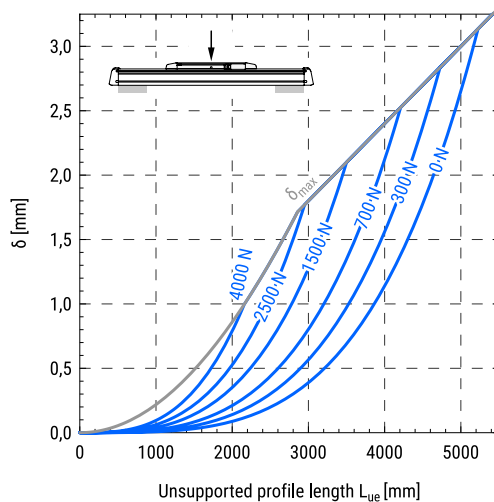

Maximum axial load as a function of travel speed of the carriage

i In the following diagrams, the maximum axial loads applied to the carriage as a function of travel speed for different voltages are presented.

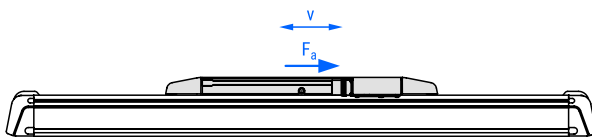

CTL 145 S Low speed

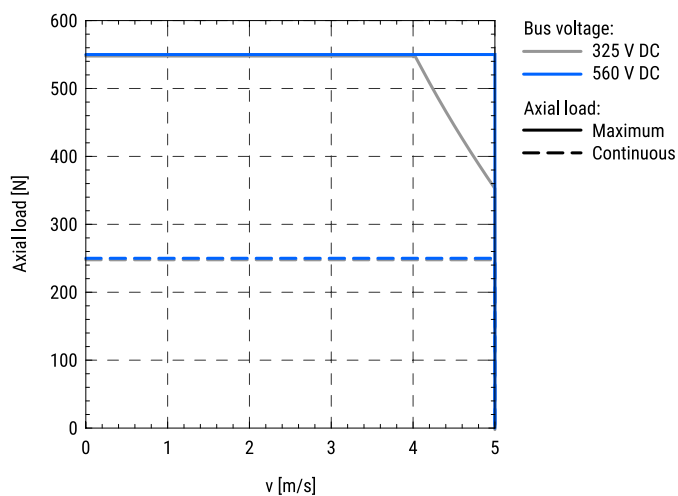

CTL 145 L Low speed

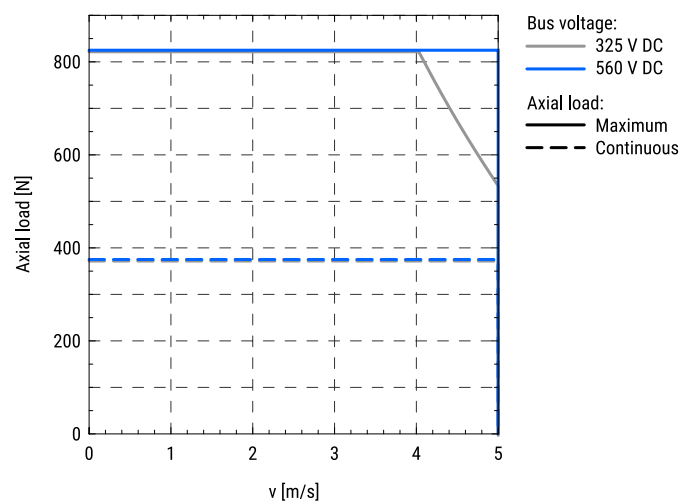

CTL 200 S Low speed

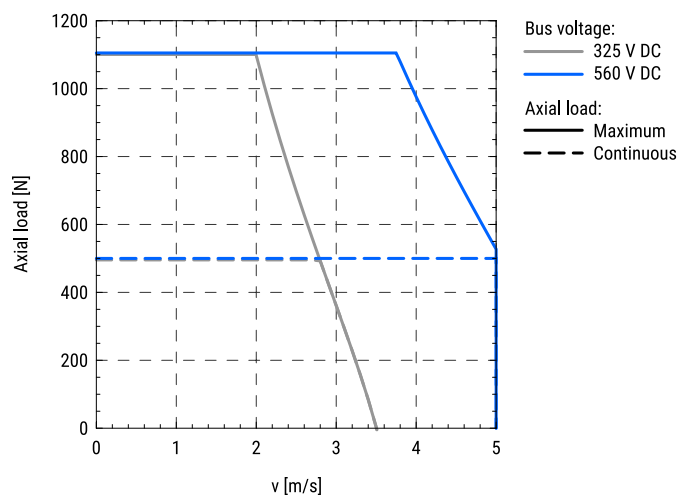

CTL 200 S High speed

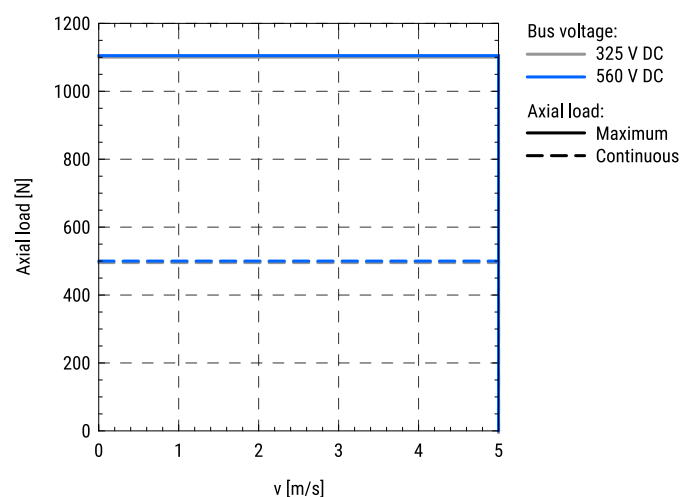

CTL 200 L Low speed

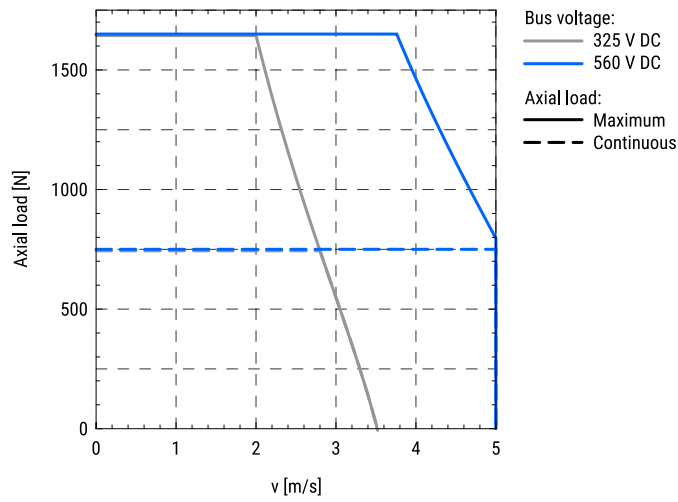

CTL 200 L High speed

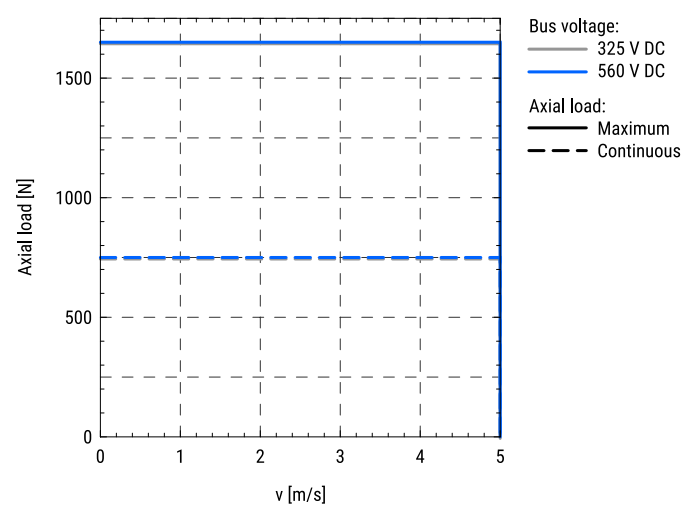

CTL 250 S Low speed

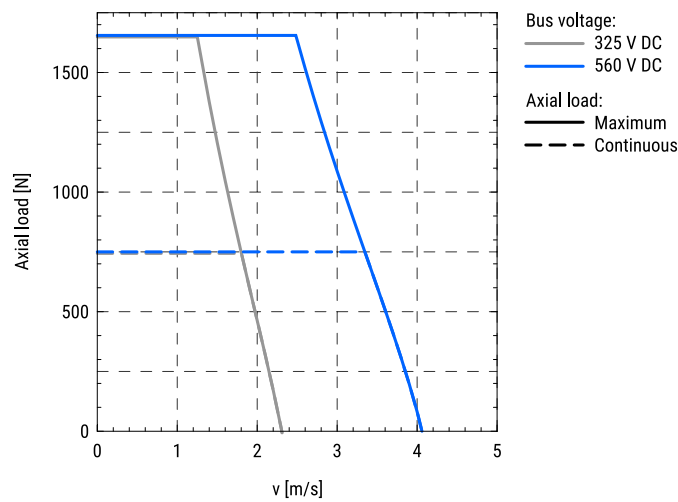

CTL 250 S High speed

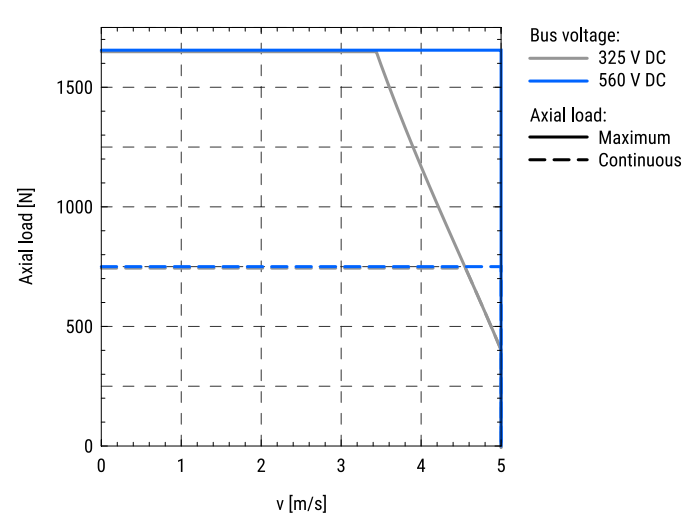

CTL 250 L Low speed

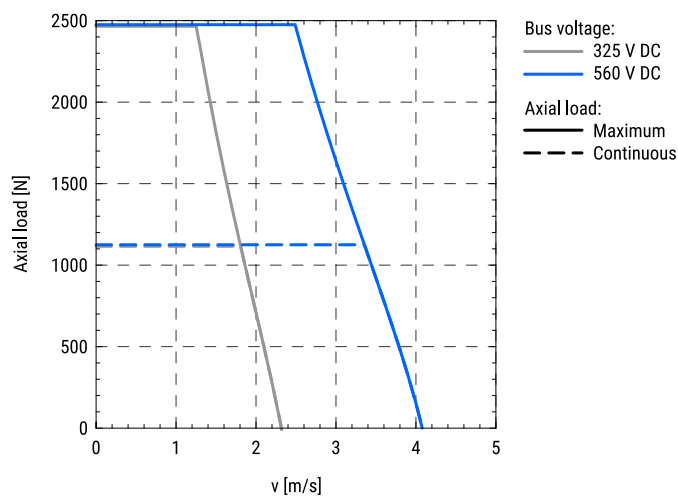

CTL 250 L High speed

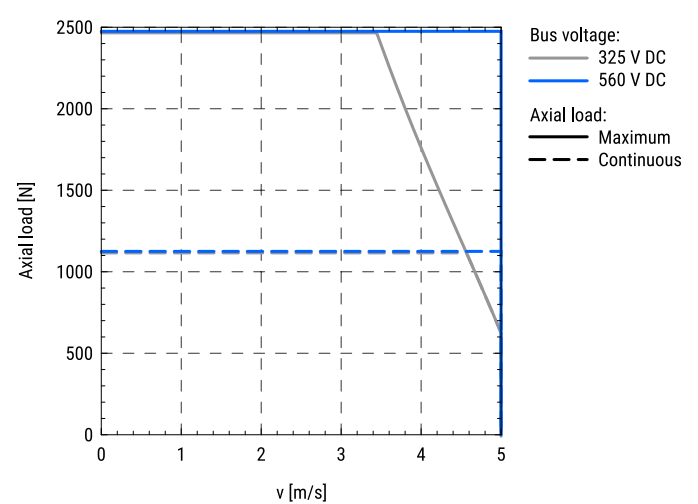

DIMENSIONS

i All dimensions are in mm. Drawing scales may not be equal.

CTL

* Only present if the IIoT option is selected.

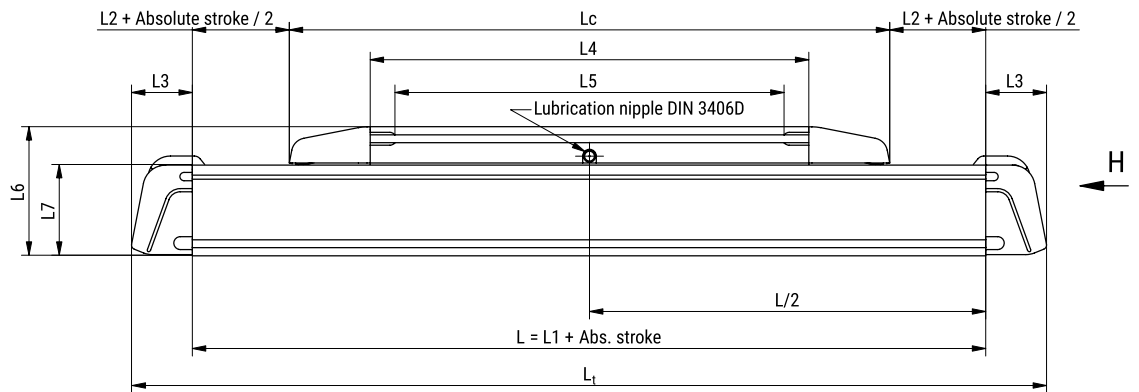

Carriage of the CTL 145 and CTL 200

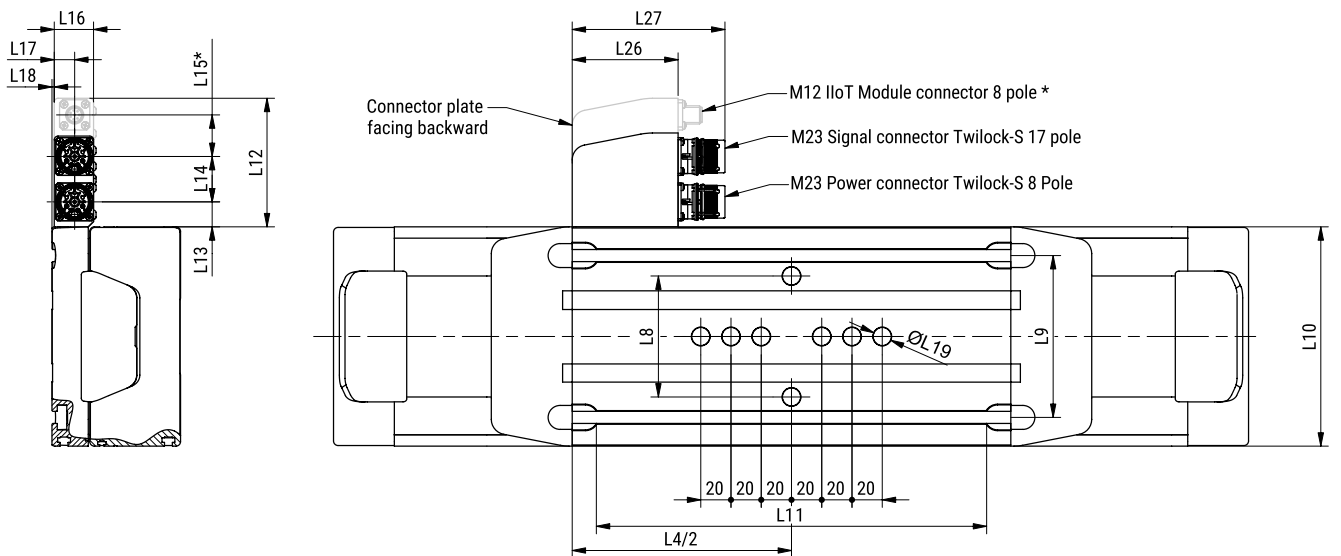

Carriage of the CTL 250

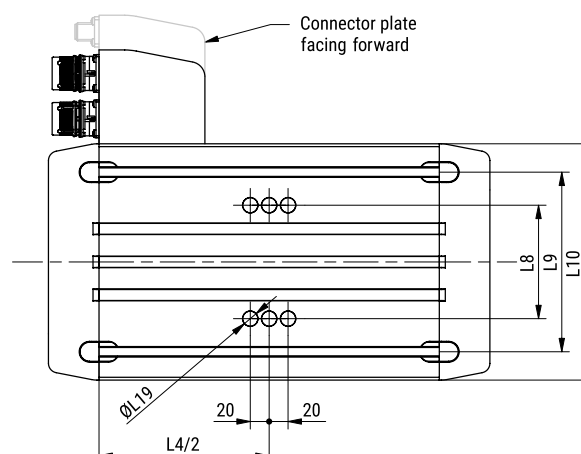

CTL	Carriage version	Lc	L1	L2	L3	L4	L5	L6	L7	L8	L9	L10	L11
145	S	397	426	14,5	40,3	290	257,3	85	60	80	107	145	258
	L	487	516	14,5	40,3	380	347,3	85	60	80	107	145	348
200	S	432	461	14,5	43,7	325	288,3	107	78	80	150	200	286,5
	L	517	546	14,5	43,7	410	373,3	107	78	80	150	200	371,5
250	S	467	496	14,5	46,1	360	341,6	119	90	120	190	250	320,9
	L	567	596	14,5	46,1	460	423,2	119	90	120	190	250	420,9

CTL	Carriage version	L12 ¹	L13	L14	L15 ¹	L16	L17	L18	∅L19 (H7)	L20	L21	L22	L23	L24	L25	L26	L27
145	S	60 (85)	16,5	30	-(27,5)	26	13	1,50	12	77	52	_ ²	8	_ ²	_ ²	70	104
	L																
200	S	60 (85)	16,5	30	-(27,5)	26	13	5	16	99	68	56	18	150	_ ²	70	104
	L																
250	S	60 (85)	16,5	30	-(27,5)	26	13	5	16	111	80	63	18	130	210	70	104
	L																

¹ If the IloT is selected refer to the vaule in the brackets

² The feature is not present on the unit

UNIMOTION

CALCULATE AND CONFIGURE YOUR OWN SOLUTION

The LINEAR UNITS CALCULATION TOOL is an online application that enables quick and easy selection of a suitable product, with the possibility of achieving the optimal ratio between the given capacity and the price, including 3D CAD models.

For more information please contact us or visit our website.

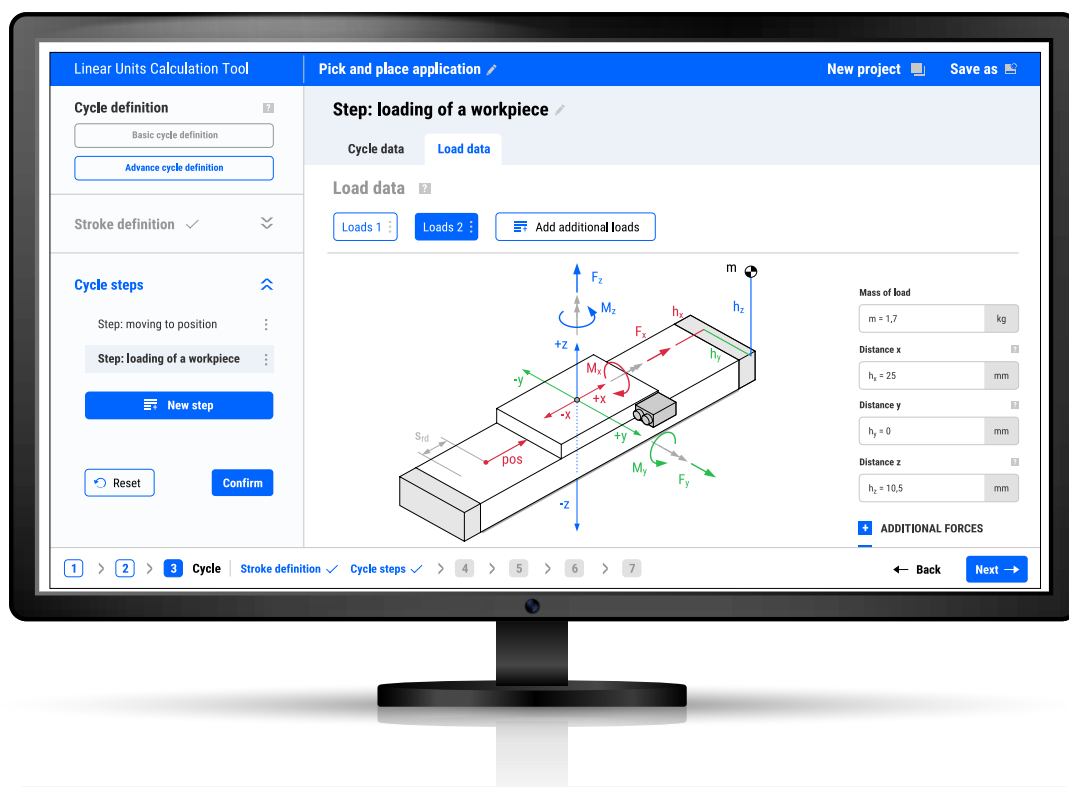

CTL slots

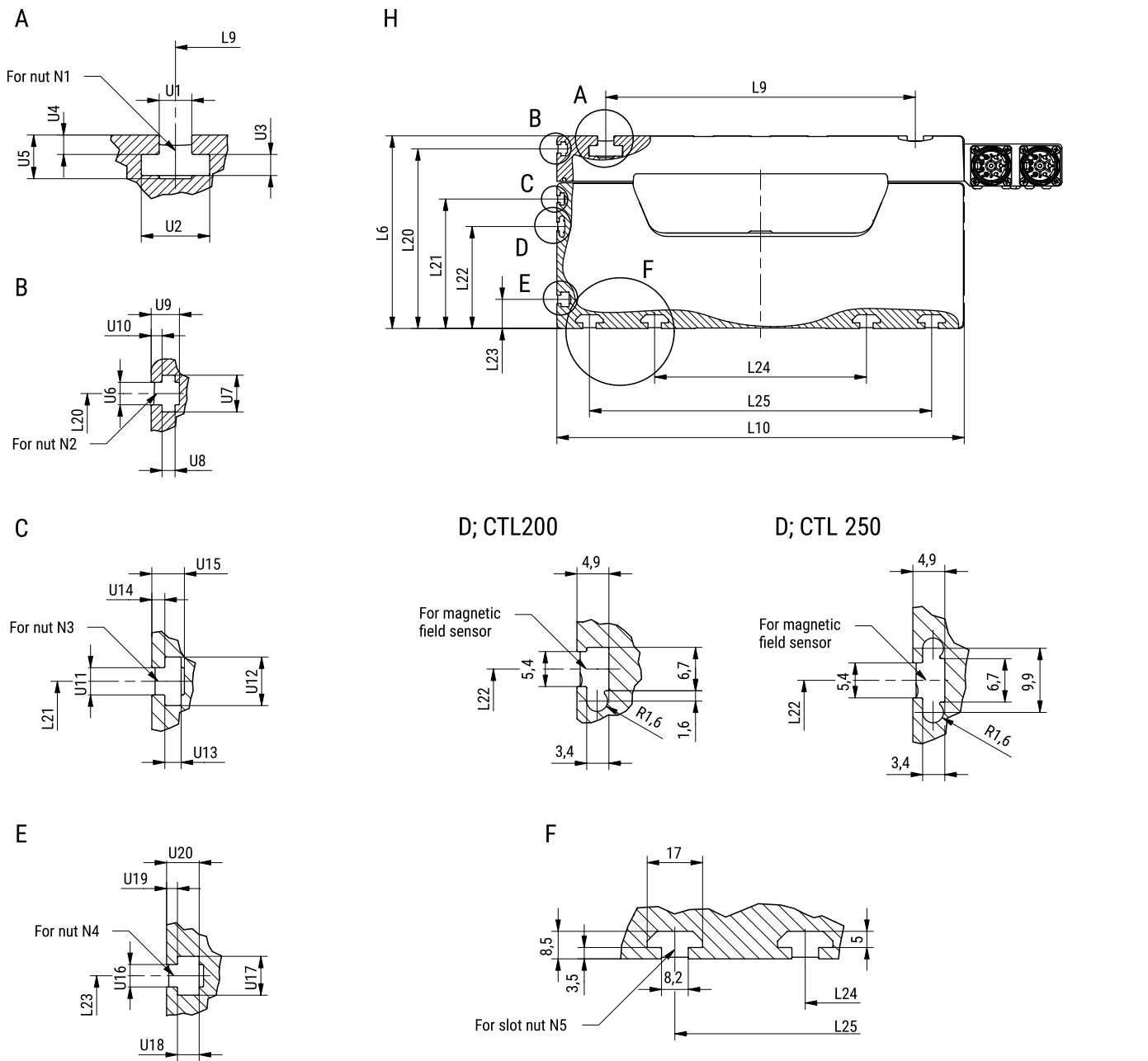

CTL	U1	U2	U3	U4	U5	U6	U7	U8	U9	U10	U11	U12	U13	U14	U15	U16	U17	U18	U19	U20
145	8	16,5	6,3	3,5	10,3	5,2	8,5	3	6	2,5	2,7	5,5	2	3,5	1	5,2	8,5	3	6	2,5
200	10	21	6,5	6	13,5	5,2	8,5	3	6,5	2,5	4,2	7,5	2,5	5	2	5,2	9	5	8,5	2,5
250	10	21	6,5	6	13,5	5,2	8,5	3	6,5	2,5	4,2	7,5	2,5	5	2	5,2	9	5	8,5	2,5

CTL	N1	N2	N3	N4	N5
145	T8	DIN562 M5	DIN562 M2,5	DIN562 M5	-
200	T10	DIN562 M5	DIN562 M4	DIN557 M5	T8
250	T10	DIN562 M5	DIN562 M4	DIN557 M5	T8

i For more information about slot nuts please refer to the section "Accessories → Connection elements → Slot nuts".

CTL with a standard energy chain

Connector orientation: Backward

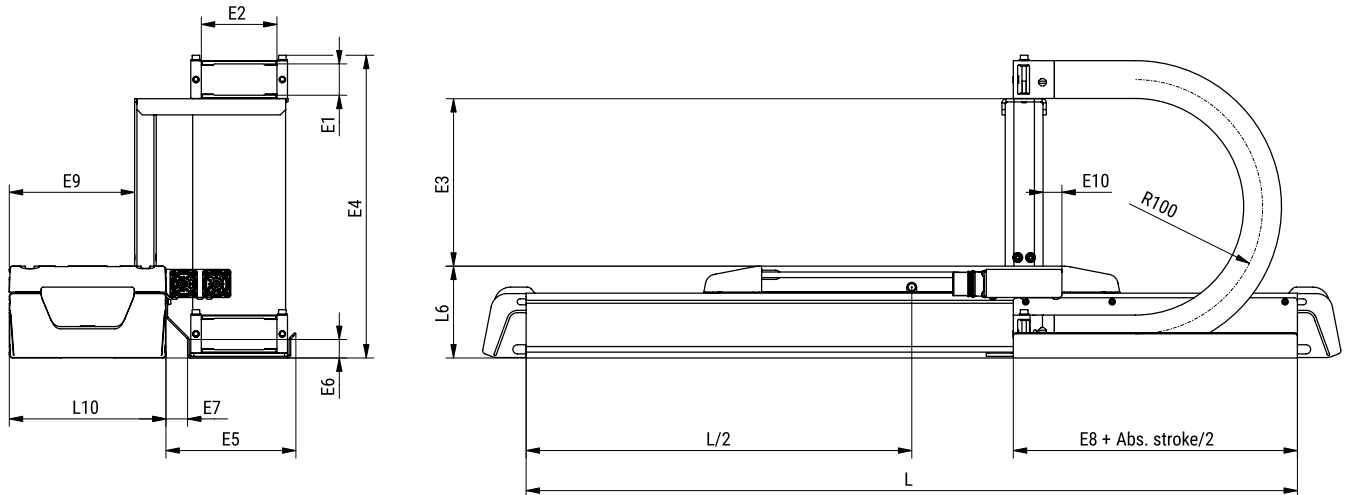

Connector orientation: Forward

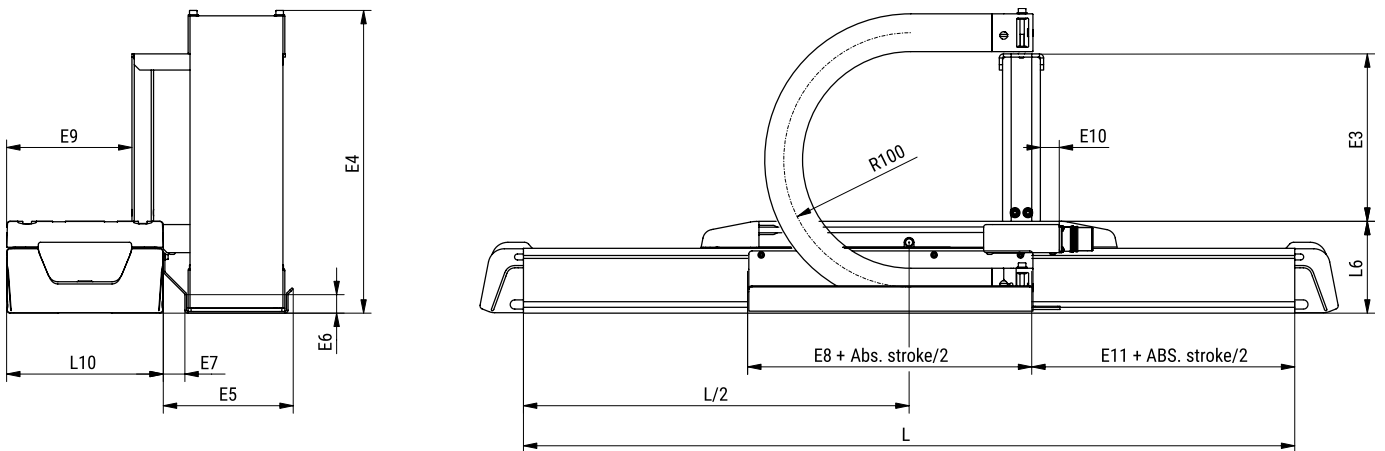

CTL	Energy chain size	E1	E2	E3	E4	E5	E6	E7	E8	E9	E10	E11
145	28×70	28	70	119,5	251,5	124,3	17	20	113	116	17,5	93,5
	28×100	28	100	119,5	251,5	154,3	17	20	113	116	17,5	93,5
200	28×70	28	70	97,5	251,5	124,3	17	20	113	165	17,5	93,5
	28×100	28	100	97,5	251,5	154,3	17	20	113	165	17,5	93,5
250	28×70	28	70	85,5	251,5	124,3	17	20	113	210	17,5	93,5
	28×100	28	100	85,5	251,5	154,3	17	20	113	210	17,5	93,5

i For more information about the standard energy chain please refer to the section "Accessories → Energy chain"

Absolute stroke and length of the CTL definition

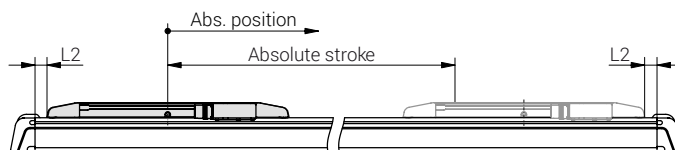

Absolute stroke definition

Absolute stroke = Effective stroke + 2 · Safety stroke

- i** The CTL does not include any safety stroke.
The absolute stroke is the distance between the two positions of the carriage that are as far apart as it is physically possible.

Length definition

$$L_t = L + 2 \cdot L_3$$

- i** Lengths L, L_t and L₃ are defined as presented on the dimensional drawings above.

Multiple carriages

Absolute stroke definition

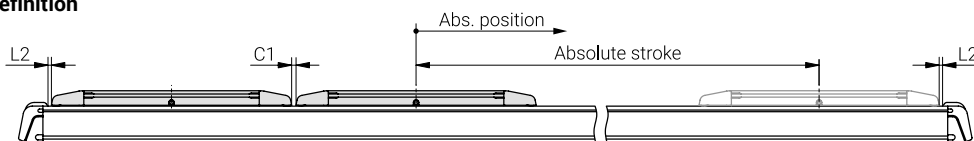

- i** The CTL does not include any safety stroke.
The absolute stroke is the distance between the two positions of the carriage that are as far apart as physically possible.

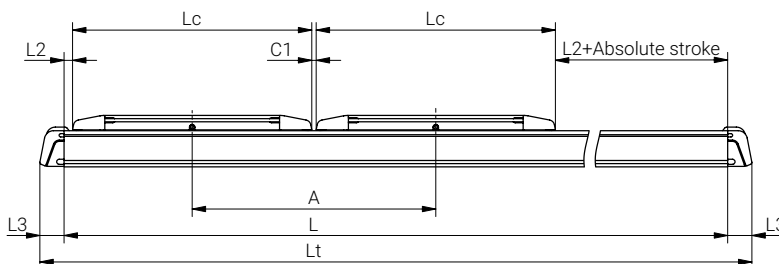

CTL	Carriage version	A ¹	C1 ²
145	S	407	10
	L	497	10
200	S	442	10
	L	527	10
250	S	477	10
	L	577	10

¹ Minimum distance between the middles of two adjacent carriages

² Minimum distance between the edges of two adjacent carriages

Length definition

$$L = L_1 + (n - 1) \cdot (C_1 + L_c) + \text{Abs.stroke}$$

$$L_t = L + 2 \cdot L_3$$

- i** Lengths L, L₁, L₂, L₃, C₁ and L_t are defined as presented on the dimensional drawings. Values of the constants can be found in the tables in chapter DIMENSIONS. Variable n is defined as the number of carriages on the CTL linear unit.

ACCESSORIES

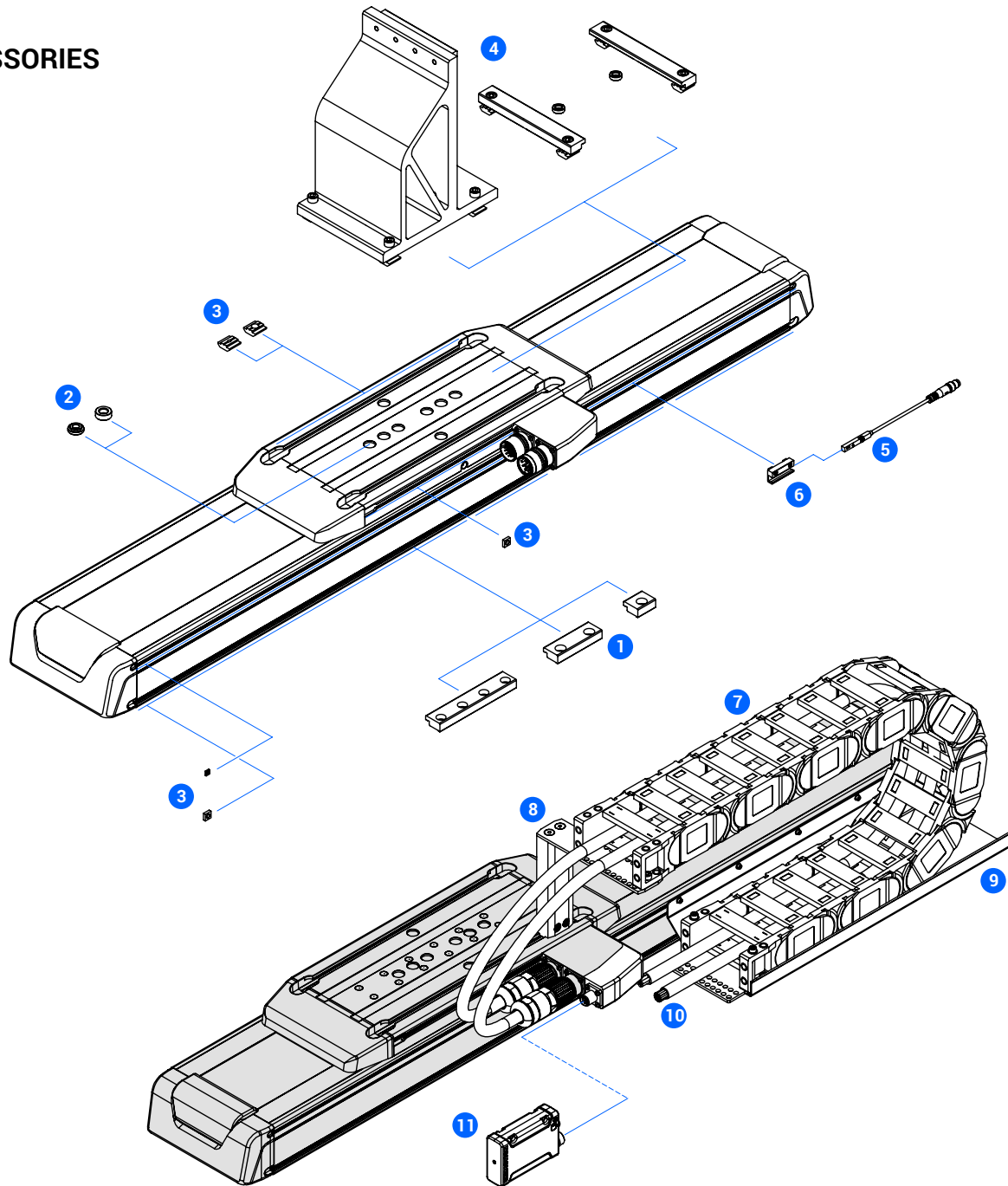

#	Accessories	Compatible with CTL size			Page	
		145	200	250		
1	Clamping fixture	•	•	•	24	Mounting attachment accessories
2	Centering ring	•	•	•	25	
3	Slot nut	•	•	•	25	
4	Connection plate	•	•	•	26	
5	Magnetic field sensor	•	•	•	27	Limit switches
6	Sensor holder	•	—	—	27	
7	Energy chain	•	•	•	28	Energy chain set
8	Energy chain holder	•	•	•	28	
9	Energy chain profile	•	•	•	28	
10	Drive-motor cables	•	•	•	29	Cables
11	IIoT module (Available soon)	•	•	•	22	IIoT

Electrical data

Linear motors	21
CTL connectors	21
Measuring systems	22
IIoT module	22
Hall Sensor	22

LINEAR MOTORS

- i** For information on what kind of linear motor is installed in a particular CTL linear unit please refer to the section “CTL → Technical data → Drive data”
For detailed information about the linear motors, please refer to the Unimotion documentation related to the linear motors via the links on page 35.

CTL CONNECTORS

Pin allocation

Motor connector

Connector type: M23 8-pole

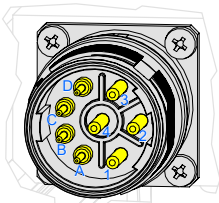

Pin	Function
1	U
2	PE
3	W
4	V
A	/
B	/
C	/
D	/

Encoder connector

Connector type: M23 17-pole

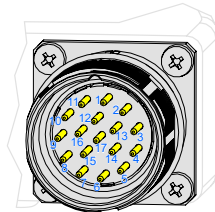

Pin	Pin allocation	
	1	2
1	B+	/
2	B-	/
3	A+	/
4	A-	/
5	ZERO+	DAT+
6	ZERO-	DAT-
7	0V (GND)	0V (GND)
8	TH+	TH+
9	TH-	TH-
10	+5V	+5V
11	/	/
12	/	/
13	/	/
14	/	/
15	HALL U	/
16	HALL V	CLK+
17	HALL W	CLK-

IloT connector

Connector type: M12 8-pole
(Available soon)

- i** For information on which pin allocation is relevant for the selected measuring system please refer to the section “Electrical data → Measuring systems”

MEASURING SYSTEMS

The measuring system in the CTL linear unit is available in four different versions.

To find out more about which options are available and what are their specifications please refer to the table below.

Technical data

Manufacturer	Scale	Readhead	Type	Communication	Resolution [mm]	Max speed [m/s]	Order code ²	Pin allocation
RLS (an associate of Renishaw)	MS10A	LM10IC005BC10F00	Magnetic incremental	Digital RS422/TTL 5V	0,005	4,67	AAB	1
		LM10IC010BC10F00		Digital RS422/TTL 5V	0,01	8	AAA	
		LM10AV000AC10F00		Analog 1 Vpp	¹	8	ABD	
	AS10A	LA11DAA11BKA10DF00	Magnetic absolute	Digital BiSS-c	0,000977	7	BCC	2

¹ Resolution is drive dependant

² Order code fields: Measuring system, Communication, Resolution

i The designated pin allocation for each measuring system option is shown in the section: "Electrical data → Pin allocation"

Detailed information

i Please refer to the manufacturer's documentation related to the measuring systems via the links on page 35.

DRIVE-MOTOR CABLES

i For information on cables refer to the section Accessories/Drive-motor cables.

IloT MODULE

UNIMOTION IloT (industrial internet of things) sensor module is a state-of-the-art technology for industrial predictive maintenance and advanced analytics.

It is a solution that gathers data from the linear motor, hall, and additional sensors and wirelessly stores it into the online cloud, where it can be accessed and processed. Gathered data can provide crucial information for predictive maintenance, machine operations, etc.

The main benefits of using an IloT module are reduced risk related to maintenance, unexpected downtime prevention, lower maintenance costs, run cycle analysis, process optimization, etc.

Overall the use of an IloT module together with our CTL linear unit can significantly extend its lifetime.

Available soon



HALL SENSOR

Universal Hall Sensor option with an integrated Analog and Digital function.

i For more information about the hall sensor please refer to the Unimotion Linear motors catalogue.

Accessories

Clamping fixtures	24
Connection elements	25
Connection plates	26
Magnetic field sensor	27
Energy chain	28
Drive-motor cables	29

CLAMPING FIXTURES

CTL linear units can be mounted to the desired surface with clamps, which are placed in the slots on the side of the profile.

Material: Anodized aluminium

i Drawings scales may not be equal.

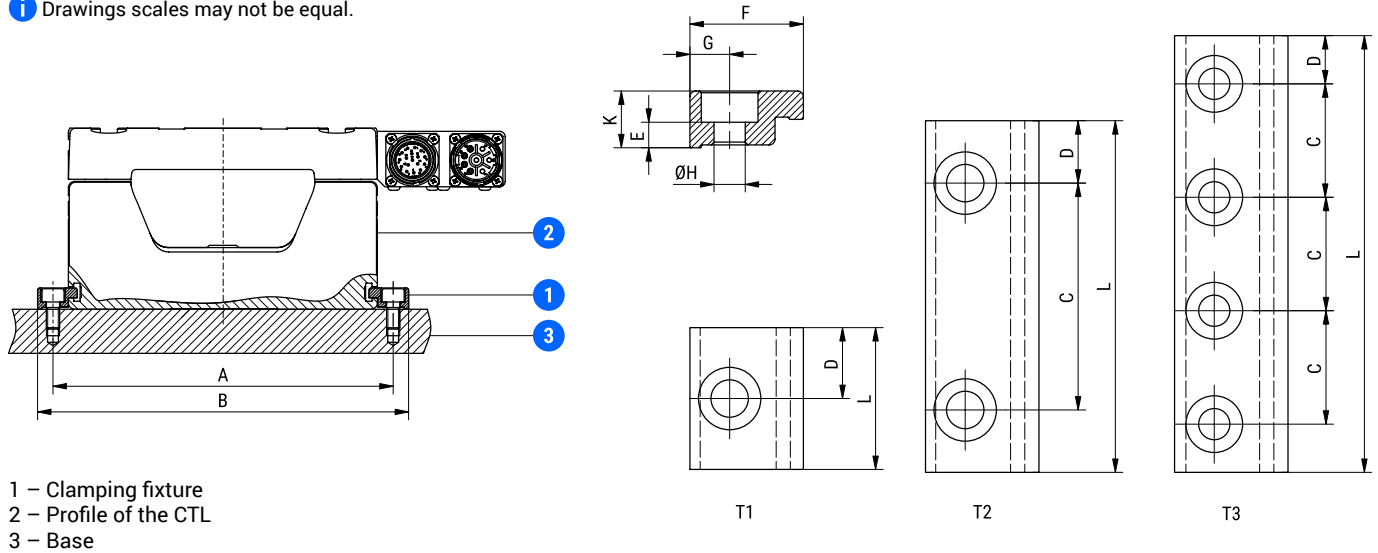

Dimensions and ordering codes

CTL	Clamping fixture			Mounting distance [mm]		Dimensions [mm]								m [g]	Code
	For screw	Type	L [mm]	A (±0,1)	B	C	D	E	F	G	ØH	K	Countersink for		
145	M6	T1	25	161	175	–	12,5	3,4	20	7	6,6	10	DIN 912	10	48642
	M6	T2	62	161	175	40	11	3,4	20	7	6,6	10	DIN 912	30	48643
	M5	T3	77	161	175	20	8,5	4,5	20	7	5,5	10	DIN 912	30	48640
	M5	T3	107	161	175	30	8,5	4,5	20	7	5,5	10	DIN 912	45	46995
200 (250)	M6	T3	142	161	175	40	11	3,4	20	7	6,6	10	DIN 912	56	55260
	M6	T1	25	213 (263)	228 (278)	–	12,5	11,5	20	7,5	6,5	20	DIN 912	17	108498
	M6	T2	60	213 (263)	228 (278)	40	10	11,5	20	7,5	6,5	20	DIN 912	54	37129
	M5	T3	77	213 (263)	228 (278)	20	8,5	14,5	20	7,5	5,5	20	DIN 912	55	49583
	M6	T3	100	213 (263)	228 (278)	27	9,5	11,5	20	7,5	6,5	20	DIN 912	69	46951

Bracketed values refer to the CTL 250

- i** Recommended number of clamping fixtures is:
- 6 T1 fixtures per meter on each side of the profile,
 - 3 T2 fixtures per meter on each side of the profile,
 - 3 T3 fixtures per meter on each side of the profile.

CONNECTION ELEMENTS

Centering rings

Material: stainless steel

Dimensions and ordering codes

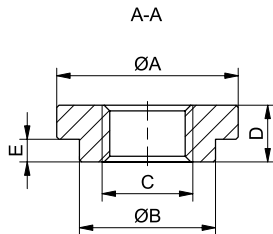

CR	A (k6)	B (k6)	C	D (+0/-0,2)	E (+0/-0,1)
9/12	12	9	M6	4	2
9/16	16	9	M6	5	2
12	12	12	M8	4	-
12/16	16	12	M8	5	2
16	16	16	M10	6	-

Centering ring compatibility

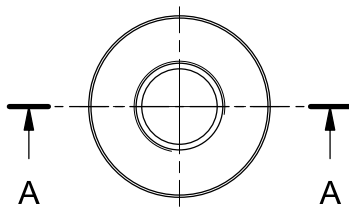

CR	CTL	m [g]	Code
9/12	145	2	48885
9/16	200, 250	5	103813
12	145	2	49049
12/16	145, 200, 250	5	102221
16	200, 250	7	53023

i Centering rings can only be used for positioning, no force should be transmitted using a CR.

Slot nuts

CTL linear unit can be mounted using the slot nuts which are placed in the slots on the profile or on the carriage. Slot nuts can also be used for mounting the accessories. On the following figure all the possible slot locations of the CTL linear unit are presented.

Material: galvanized steel

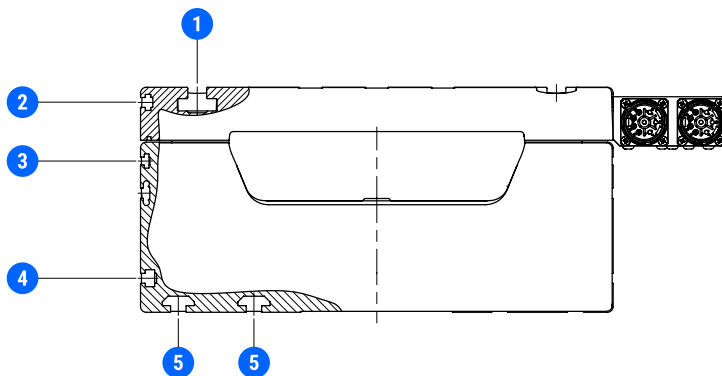

i Drawings scales may not be equal.

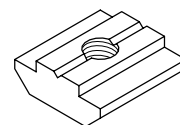

T8 / T10



DIN 557

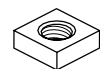

DIN 562

Nut type	CTL compatibility			m [g]	Code
	145	200	250		
T-8L-M4	1	5	5	9	5704
T-8L-M5	1	5	5	9	5703
T-8L-M6	1	5	5	8	5702
T-8L-M8	1	5	5	3	5701
T-10-M5	-	1	1	21	5553
T-10-M6	-	1	1	20	5552
T-10-M8	-	1	1	19	5551
DIN562 M2,5	3	-	-	0,5	41609
DIN562 M4	-	3	3	1	40682
DIN562 M5	4, 2	2	2	1	40768
DIN557 M5	-	4	4	2	40769

CONNECTION PLATES

CTL linear units can be mounted together using the connection plate. One linear unit can be mounted to the carriage of another and form a simple two-axis system.

Mounting of two CTL units, as well as other linear units from our product lines, listed in the table below, is possible using the connection plates. On the left and right figure below the example of XZ and XY combination of the linear units are presented, respectively.

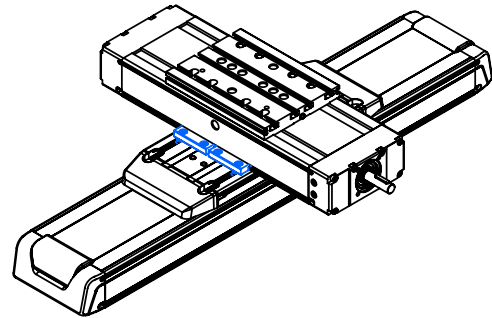
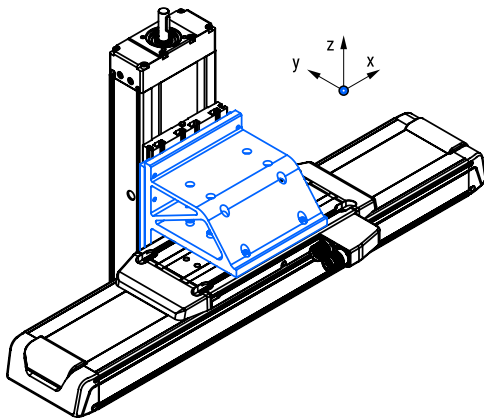

i All the materials (i.e.: screws, clamps, centering rings...) necessary for mounting the connection plate and the linear units it connects are included.

Connection plate for XY combinations

X-axis	Y-axis						
	CTL 145	CTJ 145	CTV 145	CTL 200	CTJ 200	CTV 200	CTL 250
CTL 145	•	•	•	•	•	•	—
CTL 200	—	—	—	•	•	•	•
CTL 250	—	—	—	—	—	—	•

Connection plate for XZ combinations

X-axis	Z-axis						
	MTJZ 65	MTJZ 80	MTJZ 110	CTV 90	CTV 110	CTV 145	CTV 200
CTL 145	•	•	—	•	•	—	—
CTL 200	—	•	•	—	•	•	—
CTL 250	—	—	•	—	—	—	•

MAGNETIC FIELD SENSOR

Magnetic field sensors can be mounted directly to the unit, using the slot for the magnetic field sensor placed on each side of the CTL profile.

i For the CTL size 145, an additional sensor holder (HOM) is needed.

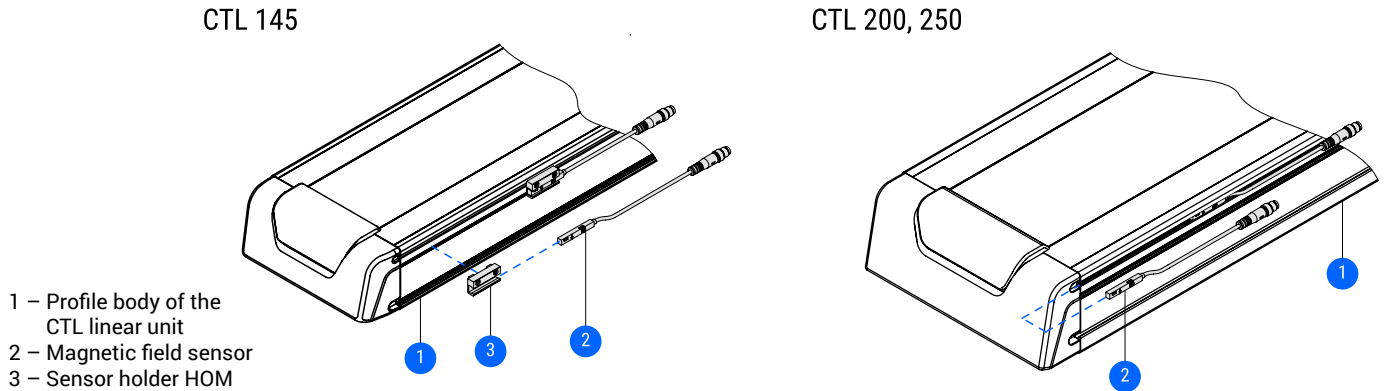

Technical data

Characteristics	SMT 65 TP K NC	SMT 65 TP K NO
Function principle	Magnetic	
Sensor type	GMR sensor	
Switching function	NC-normally close	NO-normally open
Wiring method	3-wire type	
Sensor type	PNP current sourcing	
Operating voltage	10 ~ 28 V DC	
Switching current	200 mA max.	
Contact rating	5,5 W max.	
Voltage drop	1,5 V @ 200 mA max.	
Current consumption	10 mA @ 24 V DC max.	
Operating frequency	1000 Hz max.	
Ambient temperature	-10 ~ +70 °C	
Shock / Vibration	50 G / 9 G	
Protection class	IP67	
LED indicator	Yellow	
Electrical connection	M8, 3-pin	
Cable (diameter, material, length)	∅2,8 mm, PU, 300 mm	
Extension cable	Energy chain compliant	

Ordering codes and compatibility

Type	Code	CTL
SMT-65TP-K NC	74073	200, 250
SMT-65TP-K NO	74074	
SMT-65TP-K NC + HOM	77075	145
SMT-65TP-K NO + HOM	77076	

Extension cable

Type	Connector	Length [m]	Code
Extension cable	Straight	2	8146
		5	8147
	Angled	2	9017
		5	9019

Dimensions

Magnetic field sensor SMT 65 TP K NO/NC

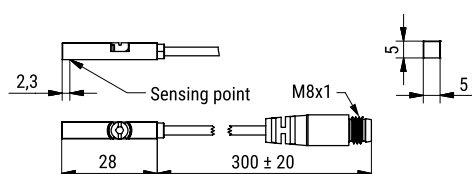

Extension cable

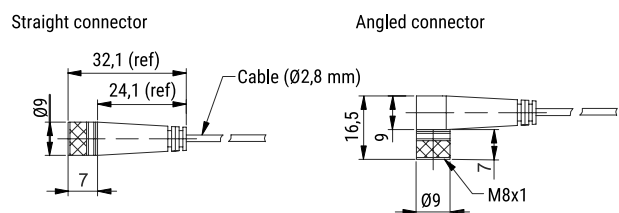

ENERGY CHAIN

- 1 – Energy chain
- 2 – Energy chain holder
- 3 – Energy chain support profile

Energy chain set

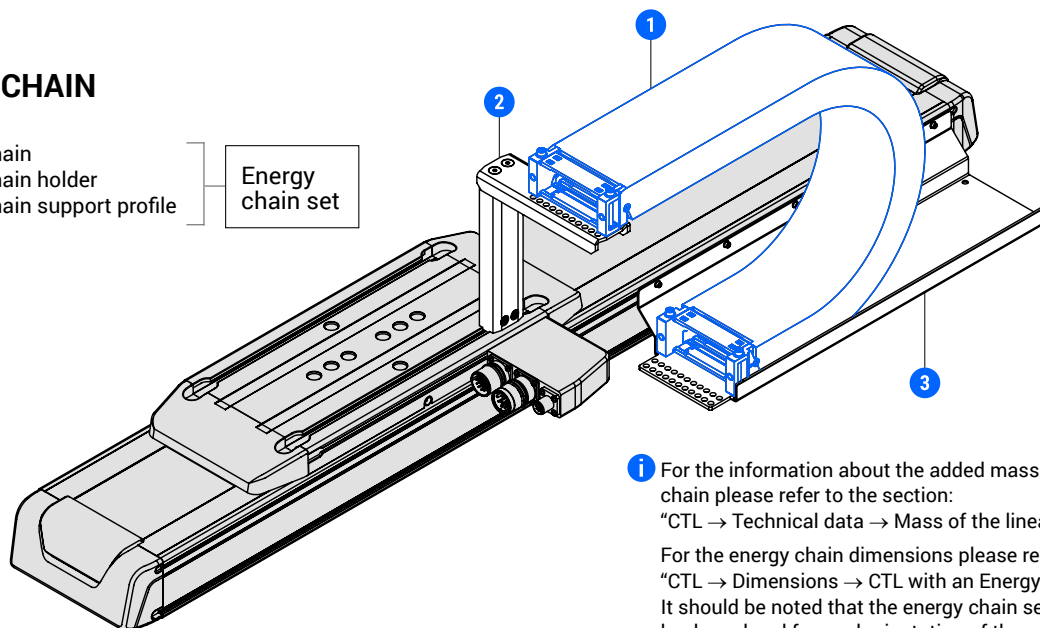

i For the information about the added mass due to the energy chain please refer to the section: “CTL → Technical data → Mass of the linear unit”

For the energy chain dimensions please refer to the section: “CTL → Dimensions → CTL with an Energy chain”

It should be noted that the energy chain set is the same for both backward and forward orientation of the carriage connector.

How to order

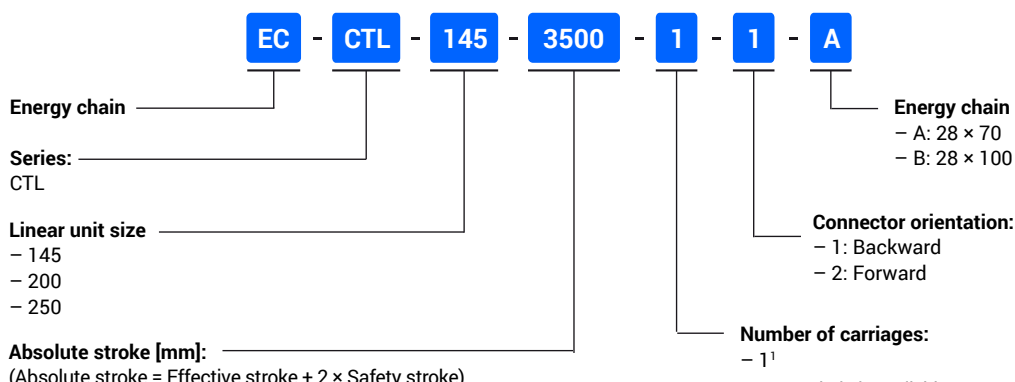

i The energy chain set includes the energy chain, the energy chain holder and the energy chain profile. All the screws and nuts required for assembly and mounting are included.

i Maximum absolute stroke up to 4800 mm is available.

¹ Energy chain is available as an accessory only for CTL linear units with single carriage.

Technical data

Characteristics	A – 28 × 70	B – 28 × 100
Energy chain inner height [mm]	28	
Energy chain inner width [mm]	70	100
Bending radius [mm]	100	
Compatible with the CTL size	145, 200, 250	
Manufacturer	igus GmbH	
Manufacturer's energy chain series	E4-28	

i In the following diagram, the fill weight of the energy chain as a function of the absolute stroke of the linear unit CTL is presented. Both running cases of the energy chain, i.e. with the straight run and with the permissible sag, are taken into consideration.

Energy chain overloading and permissible speed/acceleration

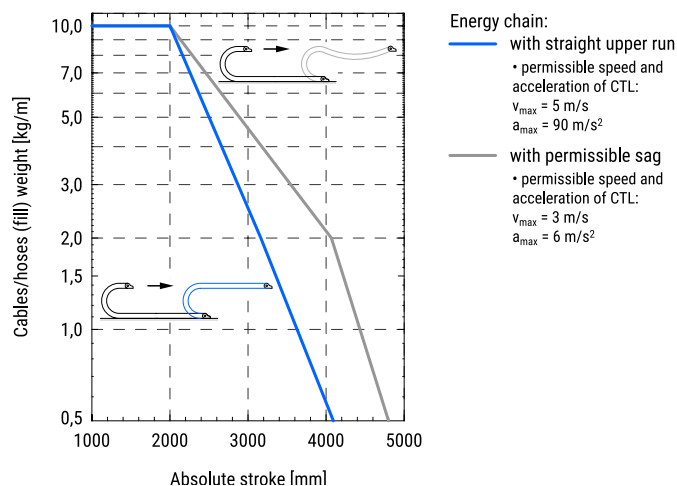

i For detailed information about the energy chain, please refer to the manufacturer documentation.

DRIVE-MOTOR CABLES

Power cable

How to order

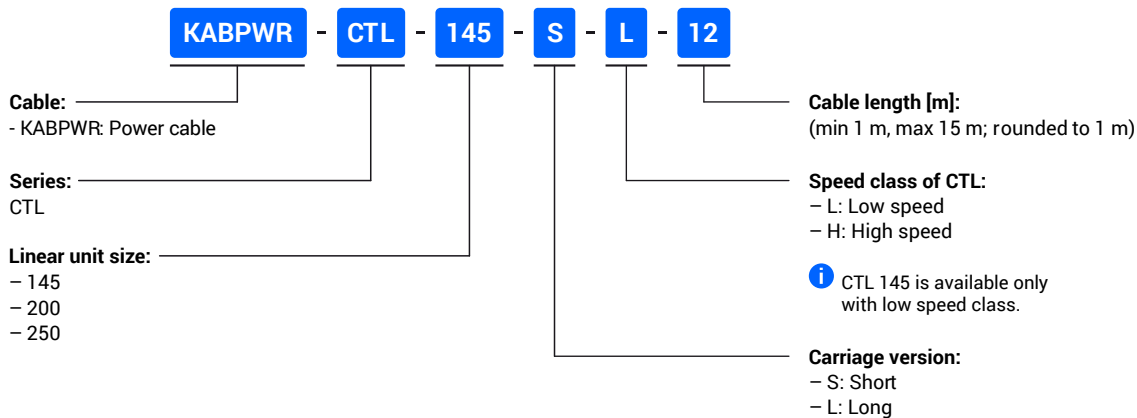

Suitability and technical data

CTL	Carriage	Speed class	Cable type	Cable diameter D [mm]	Bending radius [mm]
145	S	Low speed	4 x 1,5 + 2 x 0,34	9,1	68,25
	L	Low speed			
200	S	Low speed			
	L	High speed			
250	S	Low speed	4 x 2,5 + 2 x 0,34	10,6	79,5
		High speed			
	L	Low speed			
		High speed			

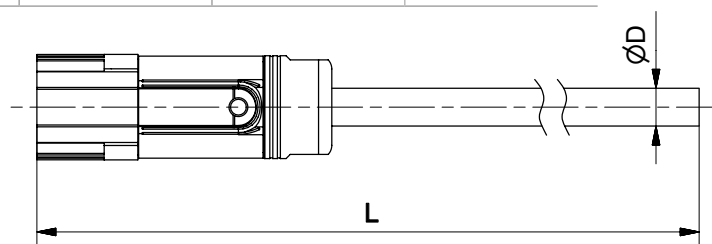

Cable pin designation

Pin number	Wire colour	Pin on CTL linear unit
1	black - U	U
2	yellow/green	PE
3	black - W	W
4	black - V	V
A	white	/
B	blue	/
C	/	/
D	/	/

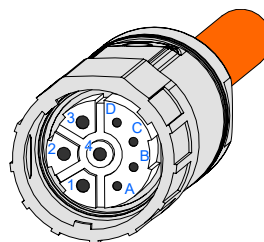

i Both cable types (4 x 1,5 + 2 x 0,34 and 4 x 2,5 + 2 x 0,34) use the same pin designation.

Signal cable

How to order

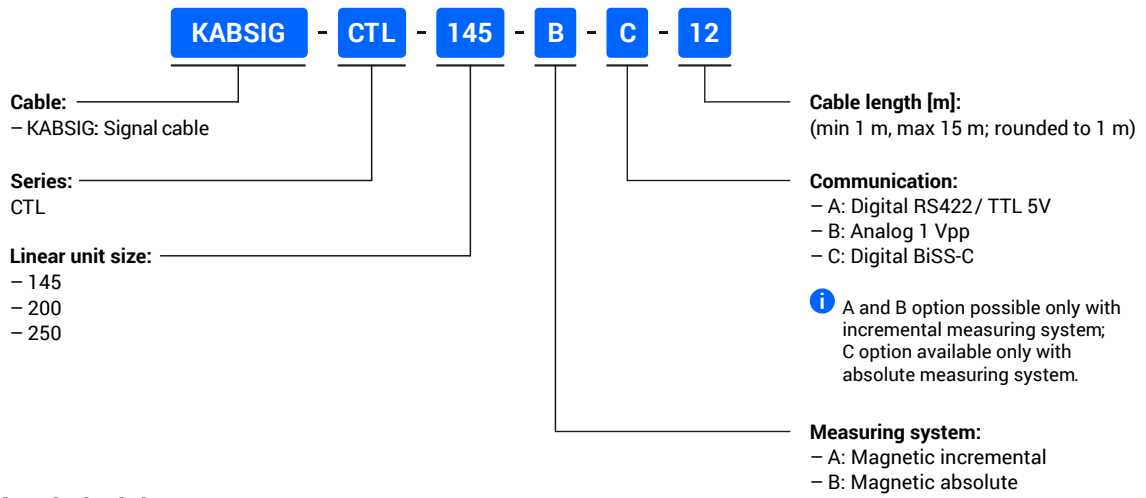

Suitability and technical data

Encoder type	Communication	Order code	Pin allocation
Magnetic incremental	Digital RS422/TTL 5V	- A - A -	1
	Analog 1 Vpp	- A - B -	
Magnetic absolute	Digital BiSS-c	- B - C -	2

Cable type [mm ²]	3 x (2 x 0,14) + 4 x 0,14 + 4 x 0,25 + 2 x 0,5
Diameter [mm]	9,5
Bending radius [mm]	71,25

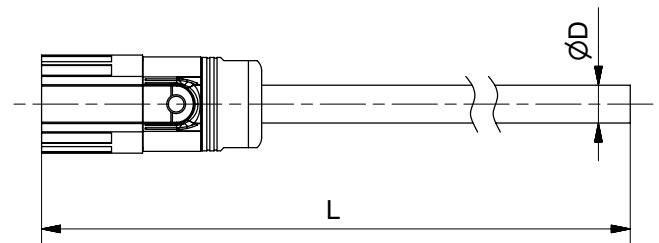

Cable pin designation

Pin number	Pin allocation 1		Pin allocation 2	
	Wire colour	Pin on CTL linear unit	Wire colour	Pin on CTL linear unit
1	red	B+	/	/
2	orange	B-	/	/
3	green	A+	/	/
4	yellow	A-	/	/
5	black	ZERO+	red	DATA+
6	brown	ZERO-	orange	DATA-
7	brown/blue	0V (GND)	brown/blue	GND
7	green/black	SEN-	green/black	SEN-
8	brown/yellow	TH+	brown/yellow	TH+
9	green/purple	TH-	green/purple	TH-
10	brown/purple	+5 V	brown/purple	+5 V
10	brown/grey	SEN+	brown/grey	SEN+
11	/	/	/	/
12	/	/	/	/
13	/	/	/	/
14	/	/	/	/
15	blue	HALL U	/	/
16	grey	HALL V	green	CLK+
17	white/black	HALL W	yellow	CLK-
Not used wires				
/	white/yellow	/	blue	/
			grey	/
			white/black	/
			white/yellow	/
			black	/
			brown	/

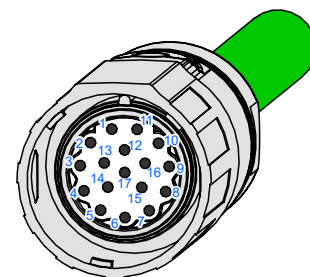

i Twisted pairs red - orange, green - yellow, black - brown are shielded. The shields are not connected.

Service life

Linear guiding.....	32
---------------------	----

LINEAR GUIDING

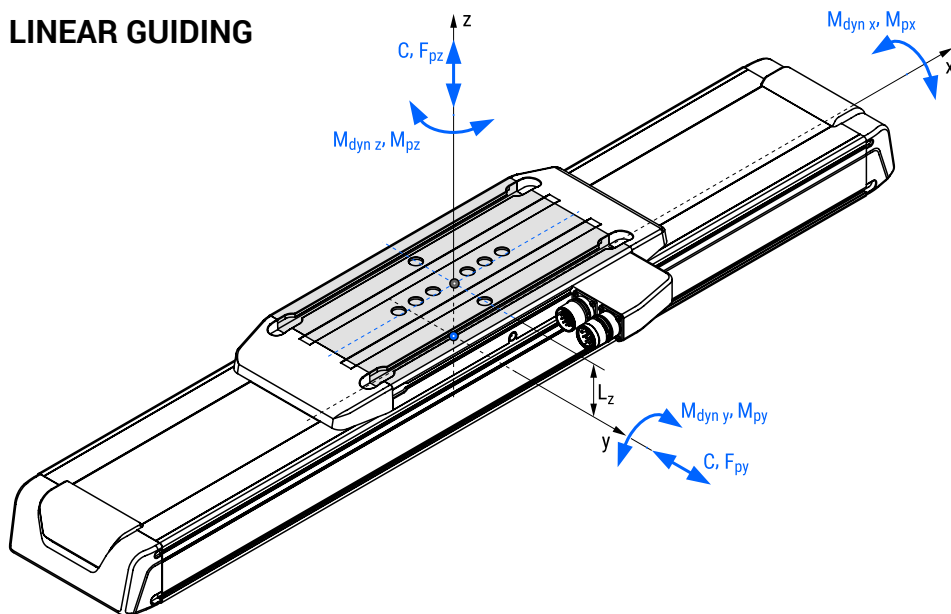

Dynamic load capacity, dynamic moments, and maximum permissible loads of the linear guiding system integrated into the linear unit all refer to the centre of the linear guides.

The applied loading condition needs to be calculated with respect to the centre of the linear guides.

The presented attachment distance L_z must be taken into consideration.

CTL	Attachment distance L_z
	[mm]
145	61,7
200	70,5
250	78,5

C	Dynamic load capacity	[N]
$M_{dyn\ x}$	Dynamic moment about the x axis	[Nm]
$M_{dyn\ y}$	Dynamic moment about the y axis	[Nm]
$M_{dyn\ z}$	Dynamic moment about the z axis	[Nm]
$F_{py\ max}$	Max. permissible force in the y direction	[N]
$F_{pz\ max}$	Max. permissible force in the z direction	[N]
$M_{px\ max}$	Max. permissible moment about the x axis	[Nm]
$M_{py\ max}$	Max. permissible moment about the y axis	[Nm]
$M_{pz\ max}$	Max. permissible moment about the z axis	[Nm]

Permissible load

Permissible load factor $f_{p\ g}$

$$f_{p\ g} = \frac{|F_y|}{F_{py}} + \frac{|F_z|}{F_{pz}} + \frac{|M_x|}{M_{px}} + \frac{|M_y|}{M_{py}} + \frac{|M_z|}{M_{pz}} \leq 1$$

i A permissible load factor of the linear guiding system $f_{p\ g}$ must never exceed the value of 1.

$f_{p\ g}$	Permissible load factor	
F_y	Applied force in the y direction	[N]
F_z	Applied force in the z direction	[N]
M_x	Applied moment about the x axis	[Nm]
M_y	Applied moment about the y axis	[Nm]
M_z	Applied moment about the z axis	[Nm]

Service life

Service life calculation

$$L_{km\ g} = \left(\frac{1}{f_{vm\ g}} \right)^3 \cdot 10^2$$

$L_{km\ g}$	Service life of the linear guiding system	[km]
$f_{vm\ g}$	Mean load comparison factor	

Mean load comparison factor f_{vmg} as a function of service life $L_{km g}$

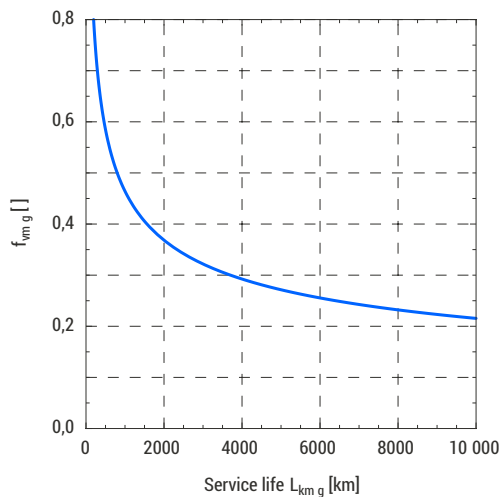

i Diagram represents the theoretically determined service life of the linear guiding system when the mean load comparison factor f_{vmg} is considered. It should be noted that the application conditions may have a significant effect on the service life.

Mean load comparison factor f_{vmg}

$$f_{vmg} = \sqrt[3]{\frac{f_{v1g}^3 \cdot s_1 + f_{v2g}^3 \cdot s_2 + \dots + f_{vng}^3 \cdot s_n}{s_1 + s_2 + \dots + s_n}}$$

$f_{vi g}$	i-th load comparison factor of a given loading regime $f_{v g}(s)$, $i \in \{1, 2, \dots, n\}$
s_i	i-th travel path of a given loading regime $f_{v g}(s)$, $i \in \{1, 2, \dots, n\}$

Loading regime $f_{v g}(s)$

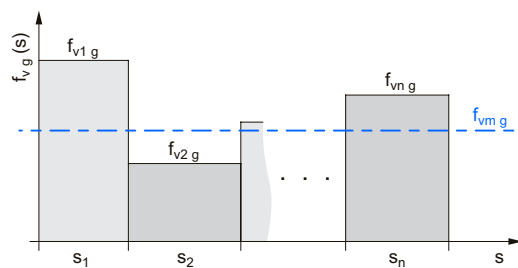

Load comparison factor $f_{v g}$

$$f_{v g} = \frac{|F_y|}{C} + \frac{|F_z|}{C} + \frac{|M_x|}{M_{dyn x}} + \frac{|M_y|}{M_{dyn y}} + \frac{|M_z|}{M_{dyn z}} + f_{v 0}$$

$f_{v g}$	Load comparison factor
$f_{v 0}$	Guiding system pretension factor

Mean dynamic safety factor f_{smg}

$$f_{smg} = \frac{1}{f_{vmg}}$$

f_{smg}	Mean dynamic safety factor
-----------	----------------------------

i The safety factor depends on the application and its requested safety. A minimum dynamic safety factor of 5,0 or more is recommended.

Guiding system pretension factor

CTL	Carriage version	$f_{v 0}$
145	S	0,088
	L	0,084
200	S	0,095
	L	0,095
250	S	0,094
	L	0,095

Links

 [Catalogue LMCA Linear motors](#)

 [Maintenance and assembly instructions CTL](#)

 [CTL connecting cables manual](#)

 [CTL measuring systems documentation](#)

 [CTL clean room certificate](#)

UNIMOTION



We cover all major markets. If you wish to contact us, send us an enquiry and we will be happy to assist you.

GERMANY

www.unimotion.de
vertrieb@unimotion.de

NORTH AMERICA

www.unimotionusa.com
info@unimotionusa.com