

SAFELY SLIDING AND LIFTING

Spieth radial plain bearings – Hydrodynamic multilobe bearings with adjustable play.

When it comes to the implementation of spindle bearings in modern, powerful machines, roller bearings are increasingly being pushed to their limits and are being replaced by sliding bearings. Hydro-dynamically lubricated, adjustable multilobe radial plain bearings manufactured by Spieth play to their strengths in the field of mechanical engineering and in machine tool engineering in particular: They allow heavily loaded spindles to lift away from the bearing surface and float on the lubricant layer. This allows the increasing requirements in terms of surface quality, dimensional accuracy, manufacturing tolerance of the work piece as well as tool service life to be fulfilled. With the high level of damping achieved by the lubricant film along with their concentricity, they combine smooth running with shock resistance and long service life.

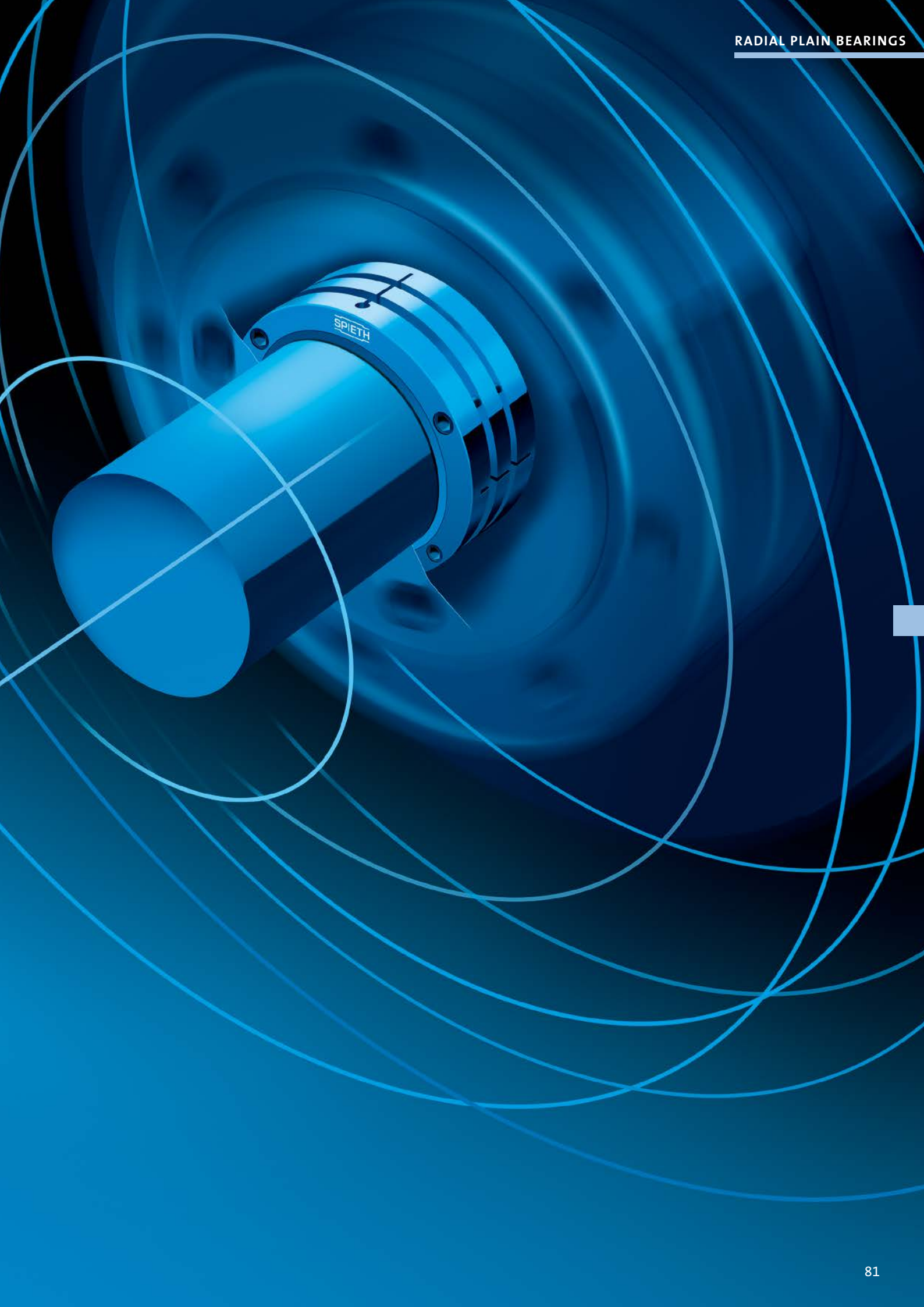

LAYOUT

- a Meander-shaped profiled steel sleeve
- b Clamping screw
- c Bearing bush made of high-quality bearing bronze

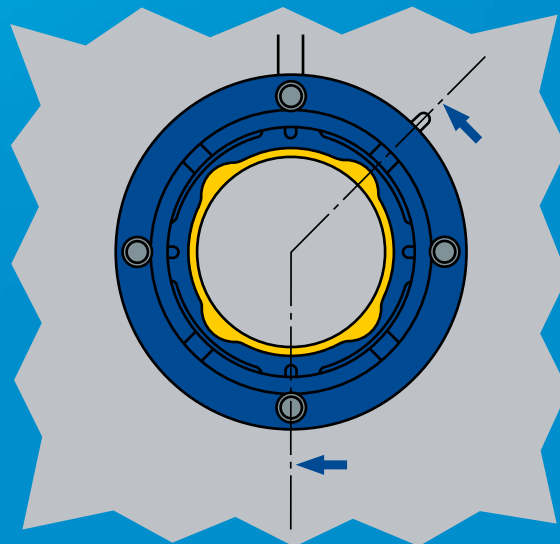
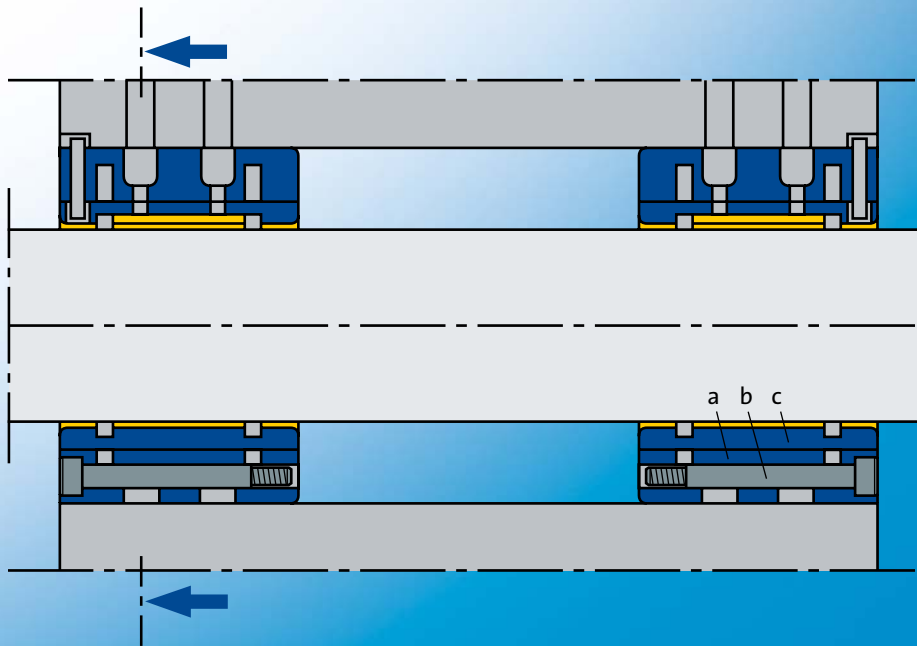

SPIETH RADIAL PLAIN BEARINGS

We'll provide you with the perfect radial plain bearings for your application. We'll also make choosing easy – with expert advice from our specialists.

BENEFITS

- Simple and precise adjustment of play.
- High degree of damping.
- High level of concentricity.
- Smooth running and shock resistant.
- Excellent emergency running properties.
- Suitable for low and high speeds.
- Independent of running direction.
- Connecting components simple to manufacture.
- Simple, quick assembly and dismantling.

FIELDS OF APPLICATION

The hydro-dynamically lubricated, adjustable multilobe radial plain bearings are used primarily in the field of mechanical engineering. Thanks to their outstanding damping, concentricity and smooth running characteristics along with their long service life, multilobe slide bearings are an excellent choice for modern powerful machines with their ever-increasing requirements in terms of surface quality, dimensional accuracy and manufacturing tolerances of work pieces. One of the most important areas of application is in cylindrical grinding machines.



GLM hydro-dynamic radial plain bearing

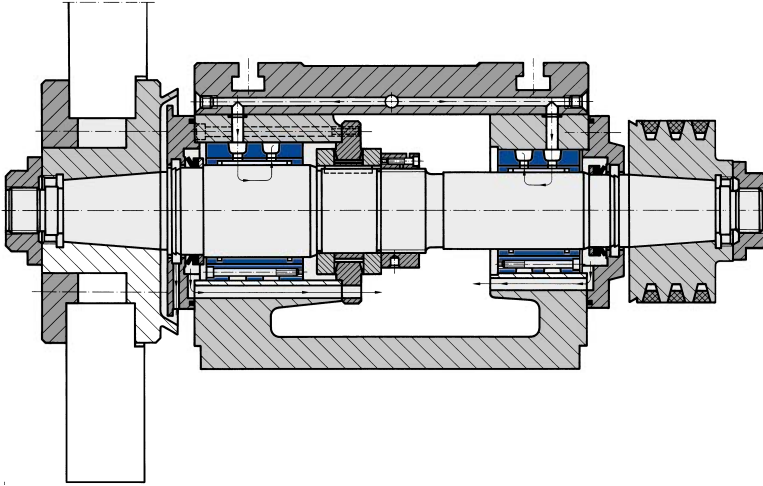

Example 1: Headstock with open housing

The adjustable GLM radial plain bearings are mounted directly in the bores of the headstock. The axial guiding is placed between the GLM, adjusted for correct play and tightened with a Spieth-Locknut against the spindle end. V-rings are used for sealing against oil loss.

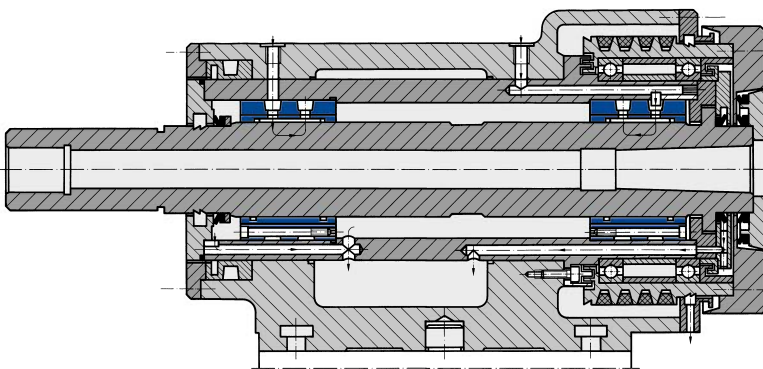

Example 2: Work piece spindle head with bearing flange sleeve and closed housing

In this stable spindle head design, radial guidance is achieved using two GLM bearings mounted in the bearing flange sleeve.

Axial guidance is provided by a spindle collar, which is located on the working side outside the GLM bearing.

A Spieth clamping set is used to eliminate the assembly play between the housing borehole and bearing flange sleeve on the spindle drive side.

V-rings are provided to prevent oil loss.

NOTE

Detailed documents are available for download at: www.spieth-me.de

SPIETH RADIAL PLAIN BEARINGS SERIES GLM

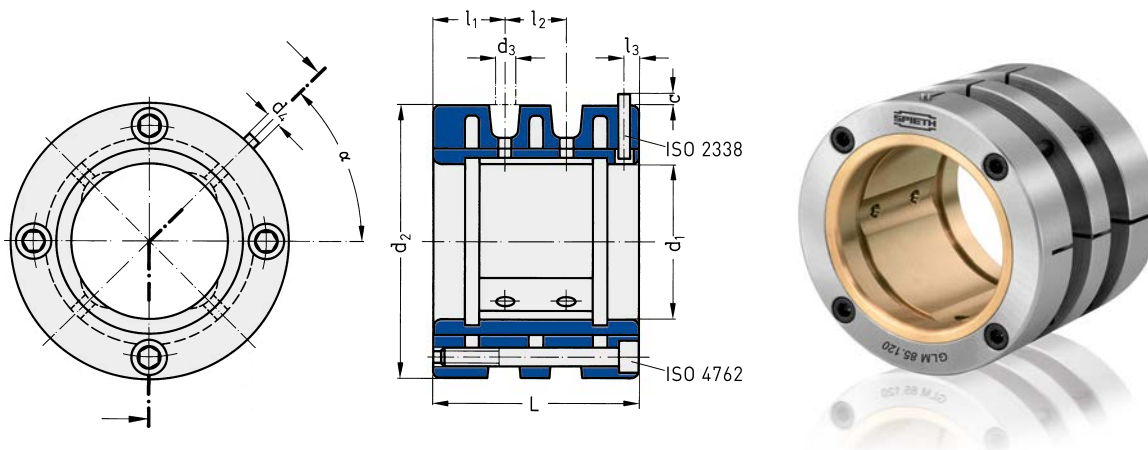

Order No.	Dimensions in mm						Cylindrical pin ISO 2338 – m6					Clamping screws	
	d ₁	d ₂	L	l ₁	l ₂	d ₃	d ₄	c	l ₃	α	Dimensions ISO 4762	No.	
	F6	h5											max
GLM 30.55	30	55	40	13.8	12.5	4	2	2	3	45	M4x35	4	
GLM 35.60	35	60	40	13.8	12.5	4	2	2	3	45	M4x35	4	
GLM 40.65	40	65	45	15	15	6	2	2	3	45	M4x40	4	
GLM 45.70	45	70	45	15	15	6	2	2	3	45	M4x40	4	
GLM 50.80	50	80	52	17.8	16.5	6	3	2	4	45	M5x45	4	
GLM 55.85	55	85	56	18.8	18.5	8	3	2	4	45	M5x50	4	
GLM 60.90	60	90	62	20.3	21.5	10	3	2	4	45	M5x55	4	
GLM 65.100	65	100	68	23.5	21	10	4	3	6	45	M6x60	4	
GLM 70.105	70	105	72	24.5	23	10	4	3	6	45	M6x65	4	
GLM 75.110	75	110	78	26	26	15	4	3	6	45	M6x70	4	
GLM 80.115	80	115	82	27	28	15	4	3	6	45	M6x75	4	
GLM 85.120	85	120	85	27.8	29.5	15	4	3	6	45	M6x75	4	
GLM 90.125	90	125	90	29.8	30.5	15	4	3	6	45	M6x80	4	
GLM 95.130	95	130	95	31	33	20	4	3	6	45	M6x85	4	
GLM 100.135	100	135	100	32.3	35.5	20	4	3	6	45	M6x90	4	
GLM 110.160	110	160	110	34.8	40.5	20	4	3	6	45	M8x100	4	
GLM 120.170	120	170	120	38.5	43	25	4	3	7	30	M8x110	6	
GLM 130.180	130	180	130	41	48	25	4	3	7	30	M8x120	6	
GLM 140.190	140	190	140	43.5	53	25	4	3	7	30	M8x130	6	

All information is supplied without liability and subject to technical changes. Please observe the operating instructions at <https://www.spieth-maschinenelemente.de/en/download-faqs/catalogueinstructions/>