

Ampco Centrifugal Pumps

DATA SHEET

MODEL ZC2 1 1/2 X 1 1/4
NICKEL ALUMINUM BRONZE

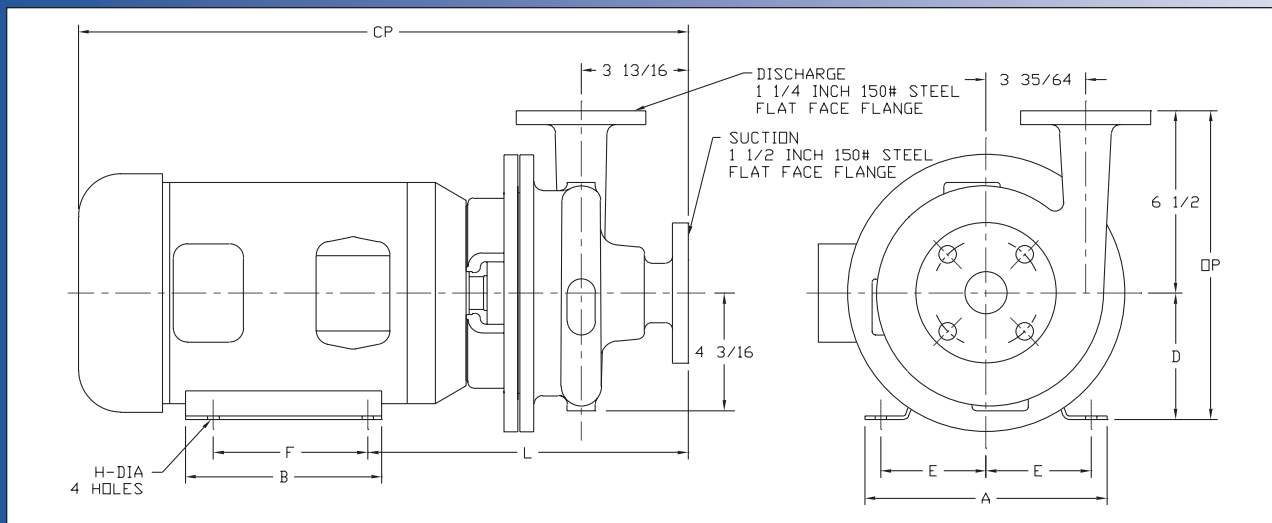
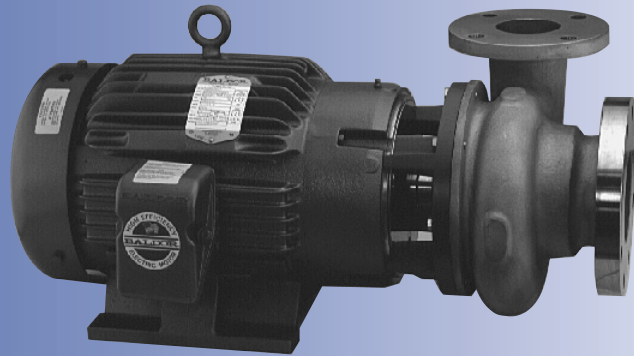

X	TEFC MOTOR			DIMENSIONS IN INCHES (For Reference Only)								APPROX. WEIGHT (LBS)	
	HP	RPM	FRAME	A	B	D	E	F	H	L	CP		OP
	1	1750	143JM	6-1/2	6	3-1/2	2-3/4	4	11/32	10-7/8	19-3/16	10	110
	1-1/2	1750	145JM	6-1/2	6	3-1/2	2-3/4	5	11/32	10-7/8	19-3/16	10	114
	2	1750	145JM	6-1/2	6	3-1/2	2-3/4	5	11/32	10-7/8	19-3/16	10	120
	2	3500	145JM	6-1/2	6	3-1/2	2-3/4	5	11/32	10-7/8	19-3/16	10	120
	3	3500	145JM	6-1/2	6	3-1/2	2-3/4	5	11/32	10-7/8	19-3/16	10	146
	5	3500	184JM	8-5/8	6-1/2	4-1/2	3-3/4	5-1/2	13/32	11-1/2	22	11	159
	7-1/2	3500	213JM	9-5/8	8-1/8	5-1/4	4-1/4	5-1/2	13/32	12-7/16	24-3/4	11-3/4	227

MATERIAL SPECIFICATIONS

PART NAME	NICKEL ALUMINUM BRONZE
Casing, Cover & Impeller	AMPCO® 483
Wear Ring	AMPCO® 18
Motor Shaft	Steel
Shaft Sleeve	AMPCO® 18
Adapter	Cast Iron



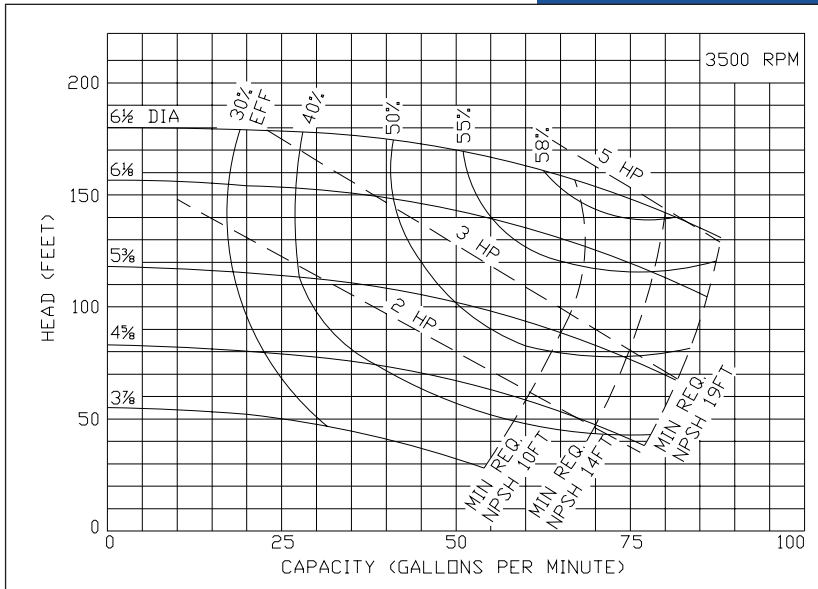

Ampco Centrifugal Pumps

**MODEL ZC2 1 1/2 X 1 1/4
NICKEL ALUMINUM BRONZE**

Curves show approximate characteristics based on clear 68° water. Rated point is guaranteed.

Heavy-duty Z Series pumps have maximum wall thickness and 150 lb. flat faced flanged connections.

Seal options include Type 21, Type 1 and Type 9 with choice of sealing materials.

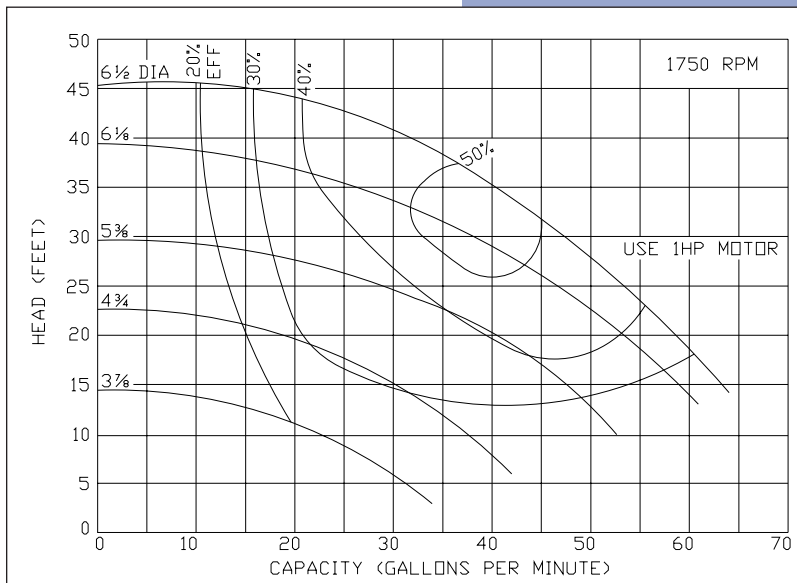
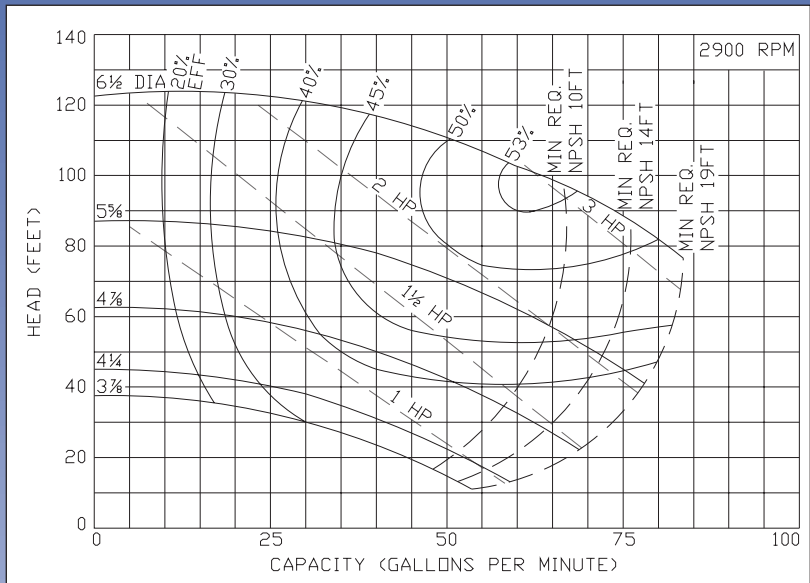

Ampco Pumps Company

4424 West Mitchell Street
Milwaukee, Wisconsin 53214
PHONE (414) 643-1852
FAX (414) 643-4452