

# Ampco Centrifugal Pumps

## DATA SHEET

MODEL SP-210 2X2

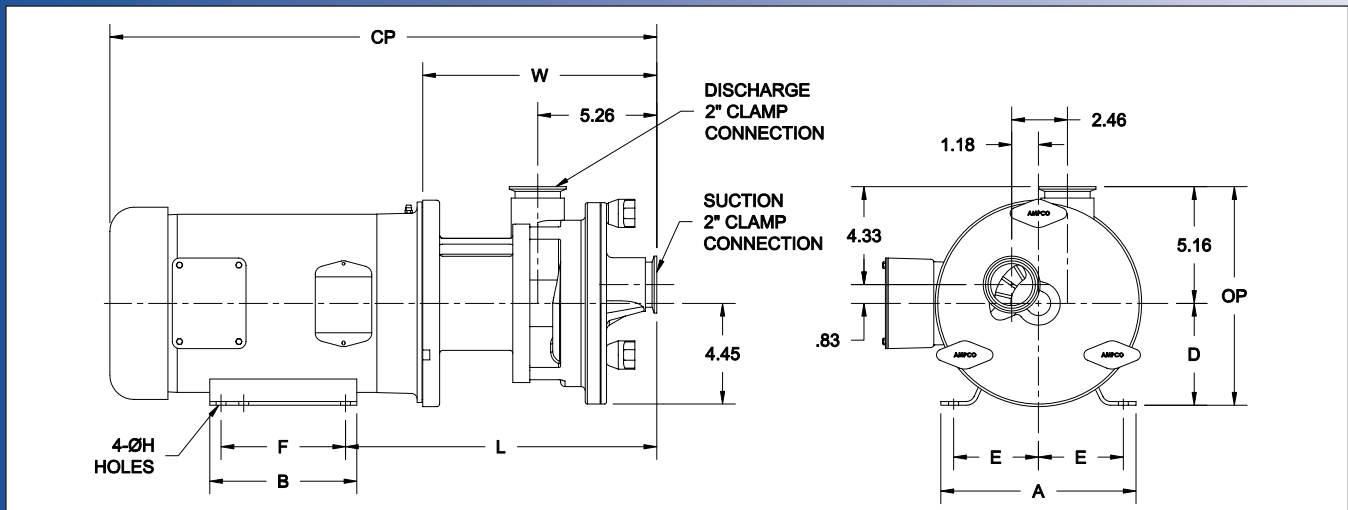
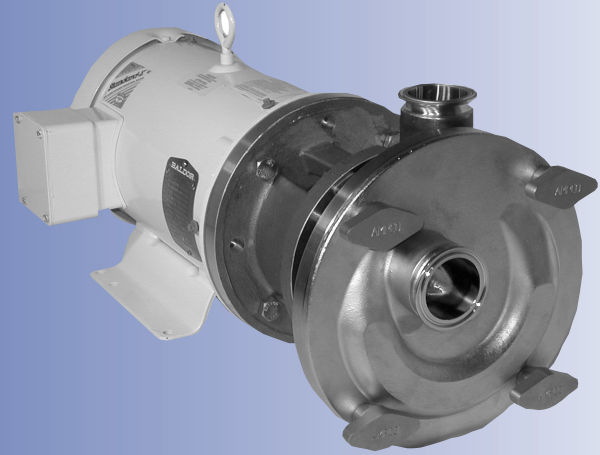

TEFC MOTOR			DIMENSIONS IN INCHES (For Reference Only)										APPROX WEIGHT (LBS)
HP	RPM	FRAME	A (typ)	B (typ)	D	E	F	ØH	L	W	CP	OP	
3	1750	182TC	8-5/8	6-1/2	4-1/2	3-3/4	4-1/2	13/32	13.66	10.28	23.95	9.66	115
5	1750	184TC	8-5/8	6-1/2	4-1/2	3-3/4	5-1/2	13/32	13.66	10.28	23.95	9.66	125

## MATERIAL SPECIFICATIONS

PART NAME	STAINLESS STEEL
Casing, Cover & Impeller	316L Stainless
Stub Shaft	316L Stainless
Adapter	304 Stainless



MODEL SP-210 2X2

# Ampco Centrifugal Pumps

Curves show approximate characteristics based on clear 68° water. Rated point is guaranteed.

SP-Series pumps have standard stainless steel adapters and silicon carbide vs. carbon seals.

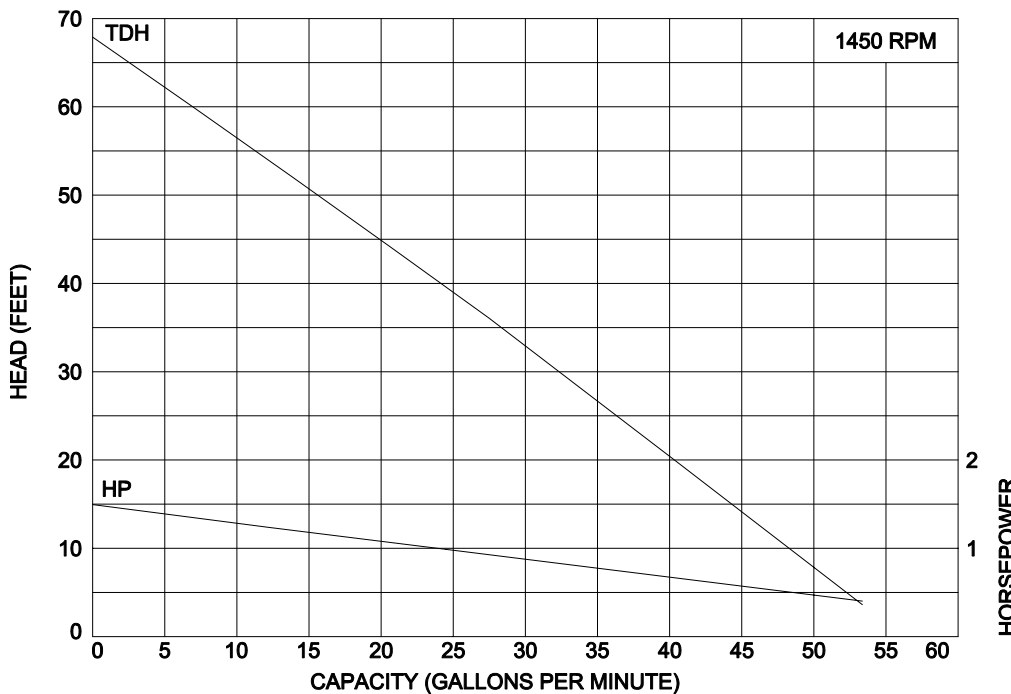
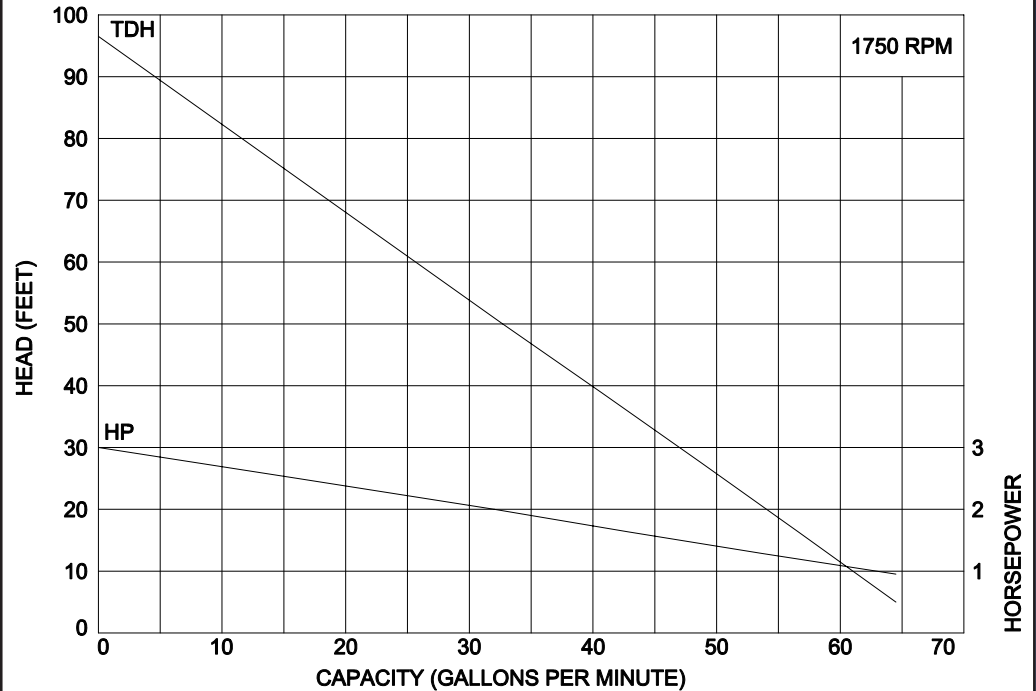

SP pumps are in conformance with 3A sanitary standards for centrifugal and positive rotary pumps for milk and milk products, Number 02-10.

SP-Series pumps have a standard 32RA (150 grit) finish, on all product contact surfaces.

## Ampco Pumps Company

Milwaukee, Wisconsin  
PHONE (414) 643-1852  
FAX (414) 643-4452