

CHARACTERISTICS

The MGBS is a ball screw driven mini linear unit where the rotary motion (rotation) of the drive shaft is converted to the linear motion (translation) of the carriage with high mechanical efficiency and low internal friction.

High-performance features such as high speed, good positioning accuracy, and high repeatability are ensured through a precision ball screw drive and a linear guiding system.

A preassembled standard motor (in-line with a motor adapter and a coupling or in-parallel with a motor side drive and a timing belt) together with a standard drive, makes the system plug and drive ready. Compact dimensions and optimally selected motor combinations cover a wide range of applications.

The aluminium profile body includes side slots for clamping fixtures as well as slots for the magnetic field sensors.

Options, such as different ball screw leads, together with a wide range of accessories and possible multi-axis system combinations make this product highly flexible.

There is also an option of the mini linear unit without the preassembled motor if an individual motor is required.

There are prepared connection and centering holes on the carriage of the mini linear unit that allow mounting of the clamping fixtures, connection plates or custom applications.

Mini linear units MGBS can be easily assembled into a multi-axis system with other MGBS or MGTB linear units and/or mini electrical cylinders MCE or mini electrical sliders MSCE.

Excellent price-performance ratio and a quick delivery time, due to standard lengths, are ensured.

Each MGBS is optimally pre-lubricated and ready for a maintenance-free operating process.

MGBS allows relatively high load capacities and optimal cycles for moving payloads at high speeds in both horizontal and vertical directions.

i The aluminium profiles are manufactured according to the EN 12020-2 standard

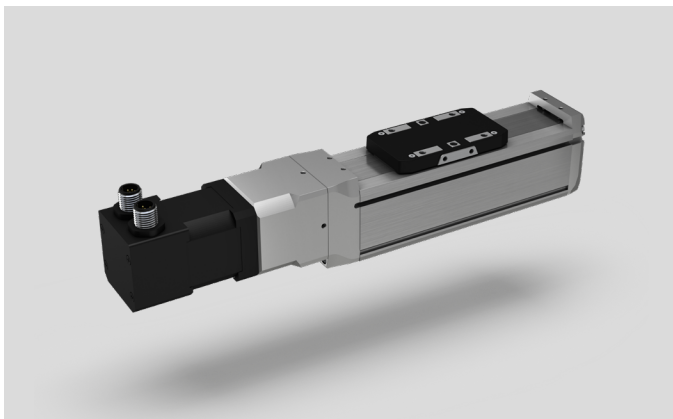

Motor adapter VK with a coupling and a motor

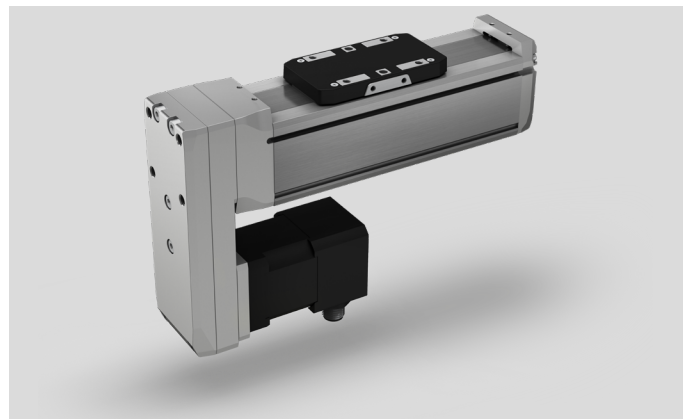

Motor side drive with a timing belt and a motor

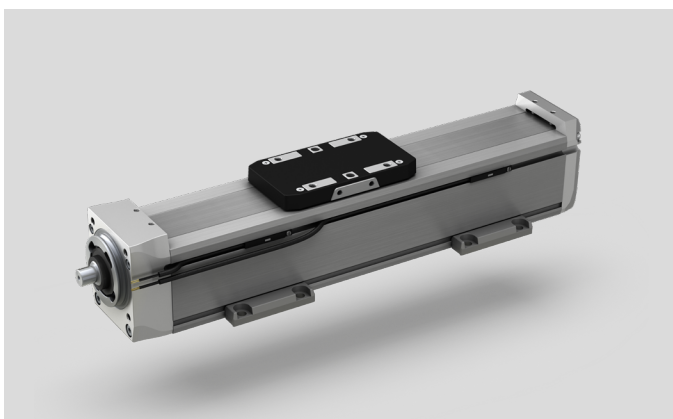

Accessories, MGBS without a preassembled motor

STRUCTURAL DESIGN

Combination with a standard motor and a motor adapter VK

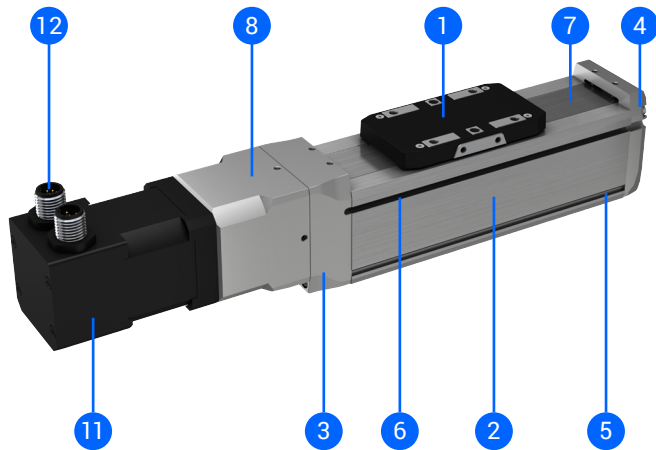

- 1 – Carriage
- 2 – Aluminium profile
- 3 – Drive block
- 4 – End block
- 5 – Mounting slots
- 6 – Slot for the magnetic field sensors
- 7 – Corrosion-resistance protection strip
- 8 – Motor adapter VK with a coupling
- 9 – Motor side drive MSD with a timing belt
- 10 – Drive shaft of the precision ball screw drive
- 11 – Preassembled motor (with/without a brake)
- 12 – Standard connectors (motor, encoder and brake – optionally)

Combination with a standard motor and a motor side drive MSD

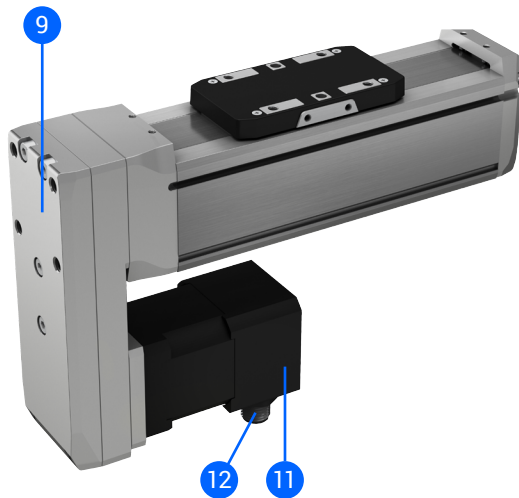

Without a motor

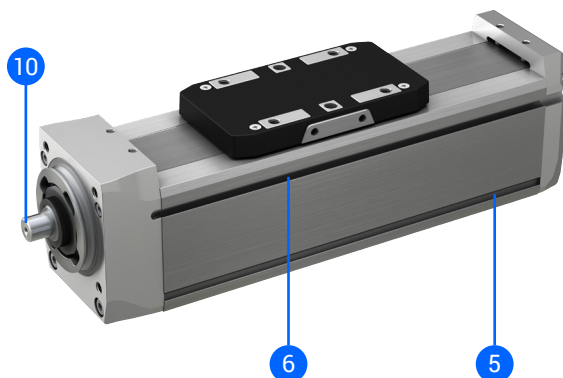

HOW TO ORDER

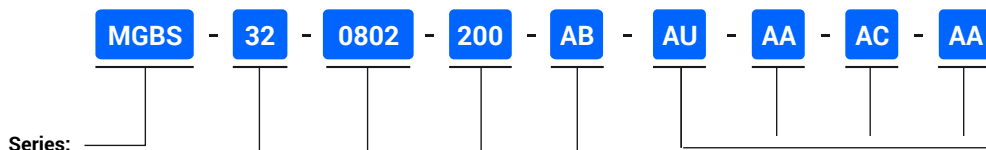

Series:
MGBS

Size:
– 32
– 45
– 60

Ball screw size:
– MGBS 32: $\varnothing 8 \times 2, \varnothing 8 \times 8$
– MGBS 45: $\varnothing 10 \times 3, \varnothing 10 \times 10$
– MGBS 60: $\varnothing 12 \times 5, \varnothing 12 \times 10$

Absolute stroke [mm]:
(Absolute stroke = Effective stroke + 2 × Safety stroke)
– 50, 100, 150, 200, 250, 300, 400, 500, 600, 700, 800, 900, 1000

i Absolute strokes of 900 and 1000 mm are only available for the MGBS 60 unit.

Motor type and size:
– Leave blank: Without a motor



Motor type:
– A: Stepper motor without a brake
– B: Stepper motor with a brake

Motor size :
– A: 28 mm (Currently not available)
– B: 42 mm
– C: 56 mm
– D: 86 mm (Currently not available)

i Available sizes:
– MGBS 32: 28, 42
– MGBS 45: 42, 56
– MGBS 60: 56, 86

For more details please refer to the section
“Electrical data → Motor types and sizes”

Motor mounting option:

– Leave blank: Without a motor

Mounting option:

- A: With a motor adapter VK
- B: With a motor side drive MSD facing up
- C: With a motor side drive MSD facing right
- D: With a motor side drive MSD facing down
- E: With a motor side drive MSD facing left

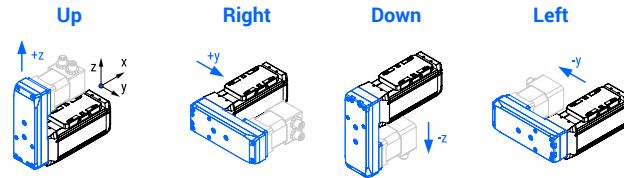

Direction of the motor connectors:

- U: Connectors facing up
- R: Connectors facing right
- D: Connectors facing down
- L: Connectors facing left

In combination with a motor adapter VK

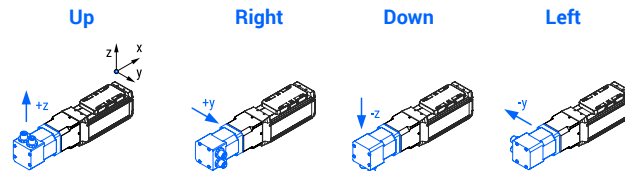

In combination with a motor side drive MSD

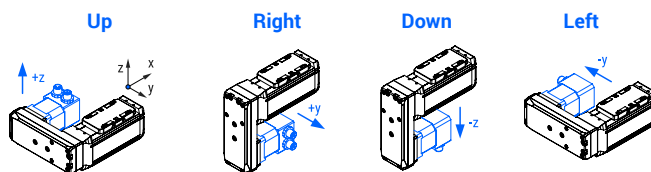

i When using the motor side drive MSD, the connectors can not be facing the MGBS otherwise, the connectors and MGBS may collide. These combinations are: BD, CL, DU and ER.

Drive option:

– Leave blank: Without a motor or drive

Drive type:

– A: Stepper

i For more details please refer to the section “Electrical data → Drive types”

Drive protocol/control:

- A: EtherCAT
- B: Ethernet based communication
- C: Pulse-direction control

Drive-motor cables option:

- Leave blank: Without a motor or drive
- 00: Without the cables

Cables type:

- A: Robotic with a straight plug
- B: Robotic with an angled plug

Cables Length:

- A: 3 m
- B: 5 m
- C: 10 m

Power and signal cables:

– Leave blank: Without a motor or drive

Power cable:

- 0: Without a power cable
- A: With a power cable

i Length of the cable = 2 m
For more details please refer to the section “Electrical data → Power and signal cables”

Signal cable:

- 0: Without a signal cable
- A: With a signal cable

i Length of the cable = 2 m
Signal cable is mandatory in for the following cases:

- If a motor with a brake is used
- If a pulse-direction drive control is used
- If the limit switches are used

For more details please refer to the section “Electrical data → Power and signal cables”

TECHNICAL DATA

General technical data

MGBS	Ball screw ⁴ d × l [mm]	Dynamic axial load capacity ¹ C _a [N]	Dynamic load capacity ³ C [N]	Dynamic moments ³			Max. permissible loads					Axial backlash (BS) ² [mm]	Max. repeatability ⁵ [mm]	Absolute stroke [mm]
				M _{dyn x} [Nm]	M _{dyn y} [Nm]	M _{dyn z} [Nm]	Forces		Moments					
							F _{py} [N]	F _{pz} [N]	M _{px} [Nm]	M _{py} [Nm]	M _{pz} [Nm]			
32	8 × 2	2000	1310	4,8	4,1	200	300	2,0	1,8	1,3	≤ 0,06	±0,015	50, 100, 150, 200, 250, 300, 400, 500, 600, 700, 800	
	8 × 8	1500												
45	10 × 3	3500	3240	20,1	17,4	400	700	7,4	6,3	4,7	≤ 0,06	±0,015	50, 100, 150, 200, 250, 300, 400, 500, 600, 700, 800	
	10 × 10	3200												
60	12 × 5	5000	11190	77,4	79,8	850	2000	29,2	30,8	31,8	≤ 0,06	±0,010	50, 100, 150, 200, 250, 300, 400, 500, 600, 700, 800, 900, 1000	
	12 × 10	3800												

¹ Dynamic axial load capacity of the ball screw drive.

This value is the basis for calculating the service life.

² Valid for ball screw drive in new condition.

³ Dynamic load capacity and dynamic moments of the linear guiding system.

These values are the basis for calculating the service life.

⁴ d = ball screw nominal diameter, l = ball screw lead (for one revolution).

⁵ Valid for one-directional axial load.

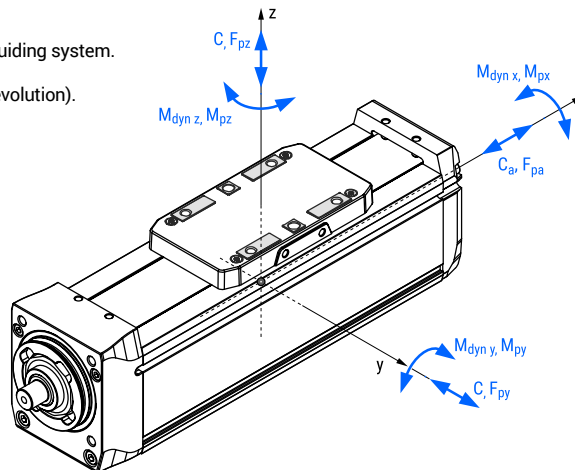

Drive data

Combination with a standard motor and a motor adapter VK

MGBS + motor and VK	Ball screw d × l [mm]	Motor		Max. permissible axial load ^{1, 2, 3} F _{pa} [N]	Max. permissible payload ^{1, 2, 3}		Max. travel speed ² v _{max} [m/s]	Max. rotational speed ² n _{max} [rev/min]	Max. acceleration a _{max} [m/s ²]
		Type	Size □ [mm]		Horizontal m _{ph} [kg]	Vertical m _{pV} [kg]			
		32	8 × 2	Stepper	28	200	31	17	0,093
42	285				31	24	0,100	3000	
8 × 8	28		50		6,2	4,1	0,300	2250	20
	42		200		31	17	0,400	3000	
45	10 × 3	Stepper	42	395	71	33	0,146	2920	20
			56	695	71	59	0,150	3000	
	10 × 10		42	120	20	10	0,477	2860	
			56	570	71	48	0,500	3000	
60	12 × 5	Stepper	56	1030	204	87	0,250	3000	20
			86	Currently not available					
	12 × 10		56	525	127	44	0,500	3000	
			86	Currently not available					

¹ This value depends on the selected motor, travel speed and acceleration of the carriage (see the following diagrams relating to the combinations with the standard motors). MGBS with an absolute stroke of 500 mm is considered.

² The value depends on the absolute stroke. The maximum permissible axial load also depends on the travel speed. Please, see the following diagrams.

³ Carriage acceleration of 2 m/s² is considered.

Combination with a standard motor and a motor side drive MSD

MGBS + motor and MSD	Ball screw d × l [mm]	Motor		Max. permissible axial load ^{1, 2, 3} F _{pa} [N]	Max. permissible payload ^{1, 2, 3}		Max. travel speed ² v _{max} [m/s]	Max. rotational speed ² n _{max} [rev/min]	Max. acceleration a _{max} [m/s ²]
		Type	Size □ [mm]		Horizontal m _{ph} [kg]	Vertical m _{pV} [kg]			
32	8 × 2	Stepper	28	160	31	13	0,064	1920	16
			42	285	31	24	0,100	3000	20
	8 × 8		28	40	6,3	3,3	0,208	1560	
			42	175	31	15	0,400	3000	
45	10 × 3		42	330	71	28	0,137	2740	13
			56	695	71	59	0,150	3000	20
	10 × 10		42	110	19	9	0,410	2460	
			56	450	71	38	0,500	3000	
60	12 × 5	56	900	204	76	0,250	3000	20	
		86	Currently not available						
	12 × 10	56	450	126	38	0,500	3000		
		86	Currently not available						

Without a motor

MGBS without a motor	Ball screw d × l [mm]	Max. permissible axial load ² F _{pa} [N]	Max. permissible payload ³		Max. drive torque M _p [Nm]	No load torque M ₀ [Nm]	Max. permissible radial load on shaft F _{pr} [N]	Max. travel speed ² v _{max} [m/s]	Max. rotational speed ² n _{max} [rev/min]	Max. acceleration a _{max} [m/s ²]
			Horizontal m _{ph} [kg]	Vertical ² m _{pV} [kg]						
32	8 × 2	285	31	24	0,10	0,04	50	0,150	4500	20
	8 × 8	285	31	24	0,40	0,05		0,600		
45	10 × 3	695	71	59	0,37	0,10	100	0,225	4500	20
	10 × 10	695	71	59	1,23	0,11		0,750		
60	12 × 5	1100	204	93	0,97	0,16	200	0,483	5800	20
	12 × 10	1100	204	93	1,95	0,17		0,967		

¹ This value depends on the selected motor, travel speed and acceleration of the carriage (see the following diagrams relating to the combinations with the standard motors). MGBS with an absolute stroke of 500 mm is considered.

² The value depends on the absolute stroke. The maximum permissible axial load also depends on the travel speed. Please, see the following diagrams.

³ Carriage acceleration of 2 m/s² is considered.

Operating conditions

Ambient temperature	0 °C ~ +50 °C
Ambient temperature without a motor	0 °C ~ +60 °C
Protection class	IP40
Duty cycle	100 %
Maintenance	Life-time pre-lubricated

i Recommended values of loads:

All the data of the dynamic load capacities (linear guiding system and ball screw drive) stated in the tables above are theoretical without considering any safety factor. The safety factor depends on the application and its requested safety and service life.

We recommend a minimum dynamic safety factor of 5,0 or more. Please refer to pages 75 to 78, where the calculation of the safety factor of the ball screw drive and linear guiding system and how the applied load affects the service life are presented.

Mass and mass moment of inertia

MGBS without a motor	Ball screw	Moved mass ¹ $m_{m, MGBS}$ [kg]	Mass of the linear unit ²	Mass moment of inertia
	$d \times l$ [mm]		m_{MGBS} [kg]	J_{MGBS} [10^{-2} kg cm ²]
32	8 × 2	0,12	0,36 + 0,0015 × Abs. stroke	0,85 + 0,0024 × Abs. stroke + 0,1013 × m_{load}
	8 × 8			1,04 + 0,0025 × Abs. stroke + 1,6211 × m_{load}
45	10 × 3	0,23	0,80 + 0,0028 × Abs. stroke	3,17 + 0,0055 × Abs. stroke + 0,2280 × m_{load}
	10 × 10			3,72 + 0,0056 × Abs. stroke + 2,5330 × m_{load}
60	12 × 5	0,53	1,80 + 0,0049 × Abs. stroke	11,04 + 0,0132 × Abs. stroke + 0,6333 × m_{load}
	12 × 10			11,97 + 0,0126 × Abs. stroke + 2,5330 × m_{load}

¹ The moved mass is already considered in the equation for calculating the mass of the linear unit m_{MGBS} and the mass moment of inertia J_{MGBS} . The moved mass includes the mass of the carriage together with the ball nut.

² For the combination with a standard motor and motor adapter VK or motor side drive MSD the mass m_{MGBS} should be increased by m_{VK+m} or m_{MSD+m} respectively, see the table below.

Abs. stroke	Absolute stroke	[mm]
m_{load}	Applied mass to be moved	[kg]

Additional mass of the linear unit when combining the motor with the motor adapter VK or the motor side drive MSD

MGBS	Motor		Motor without a brake		Motor with a brake	
			Mass of the motor and motor adapter VK	Mass of the motor and motor side drive MSD	Mass of the motor and motor adapter VK	Mass of the motor and motor side drive MSD
	Type	Size □ [mm]	m_{VK+m} [kg]	m_{MSD+m} [kg]	m_{VK+m} [kg]	m_{MSD+m} [kg]
32	Stepper	28	Currently not available			
		42	0,52	0,62	0,65	0,75
45		42	0,57	0,71	0,70	0,84
56		1,31	1,49	1,50	1,68	
60		56	1,50	1,73	1,69	1,92
		86	Currently not available			

Planar moment of inertia

MGBS	Profile	
	I_y [cm ⁴]	I_z [cm ⁴]
32	4,3	4,6
45	14,3	15,9
60	43,8	50,3

Holding torque of a motor brake

Motor		Holding torque (brake) [Nm]
Type	Size □ [mm]	
Stepper	28	Currently not available
	42	0,4
	56	1,0
	86	Currently not available

Deflection of the linear unit as a function of a vertical force and the unsupported profile length

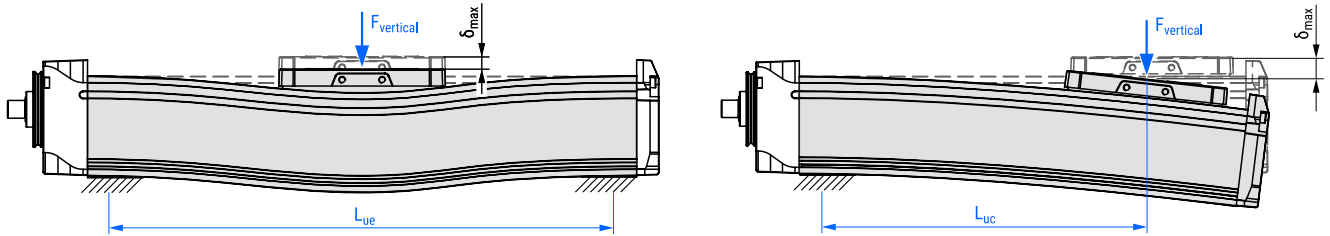

i In the following diagrams, the deflection of the linear unit as a function of a vertical force and unsupported profile length is presented. For the case of both ends of the profile are supported and for the case of a console mounting the left and the right diagrams below should be considered, respectively.

MGBS 32

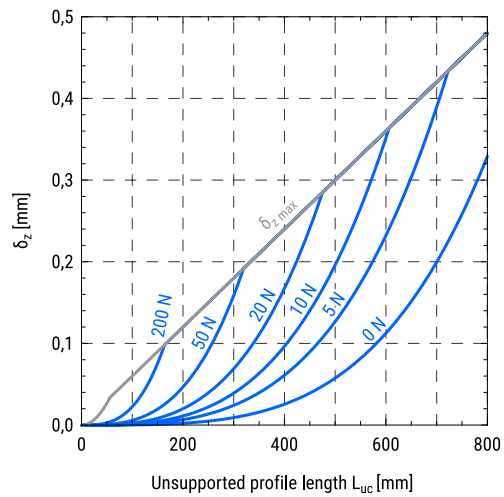
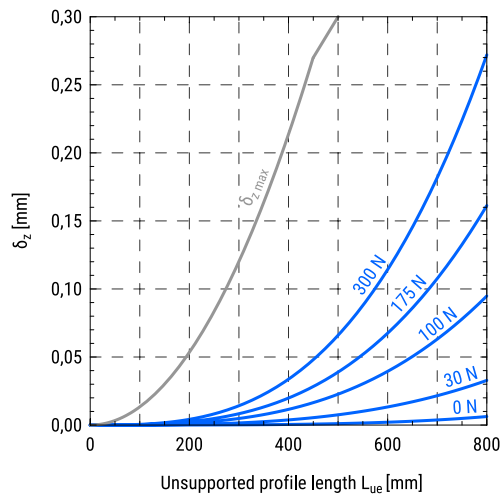

MGBS 45

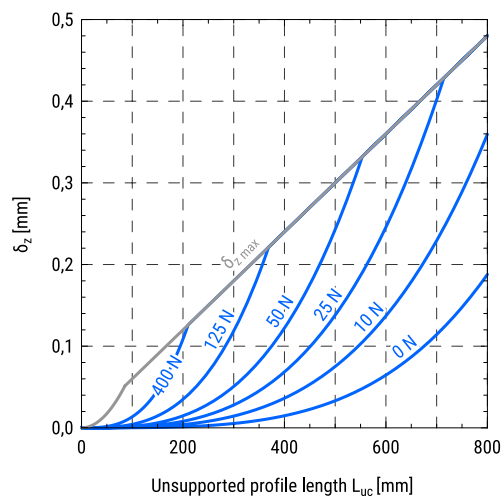
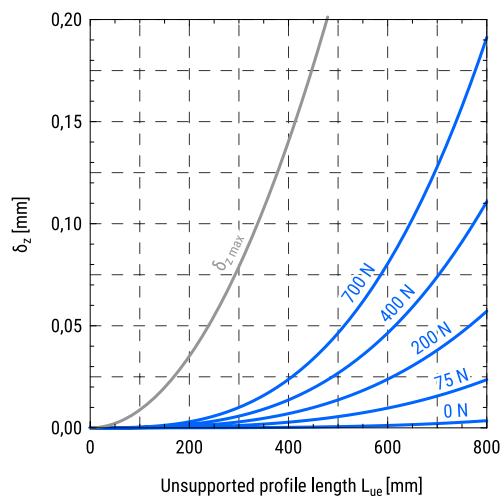

MGBS 60

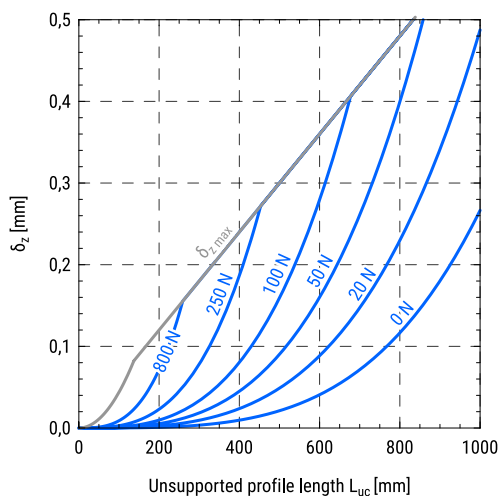
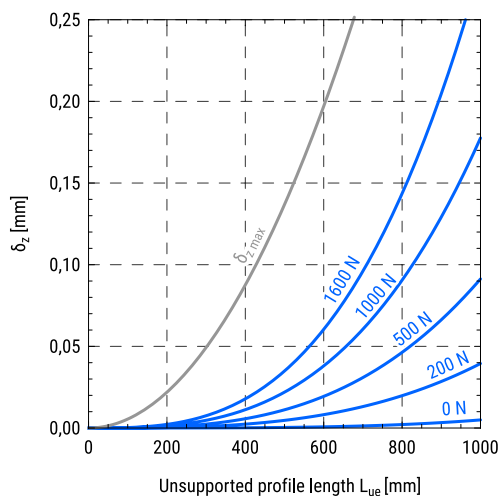

Maximum travel speed of the carriage as a function of the absolute stroke

MGBS 32

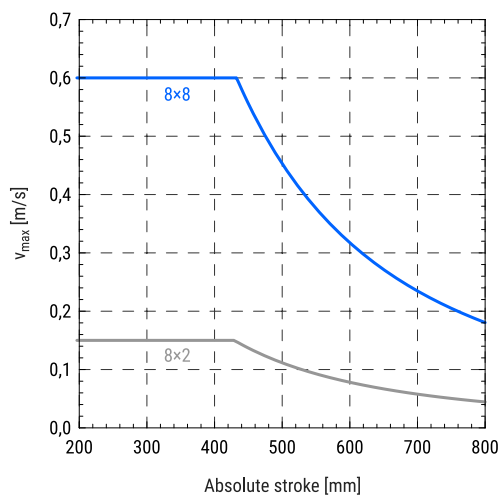

i In the following diagrams, the maximum travel speed of the carriage as a function of absolute stroke for a different ball screw lead is presented. Values on the curves represent a ball screw lead of the linear unit.

MGBS 45

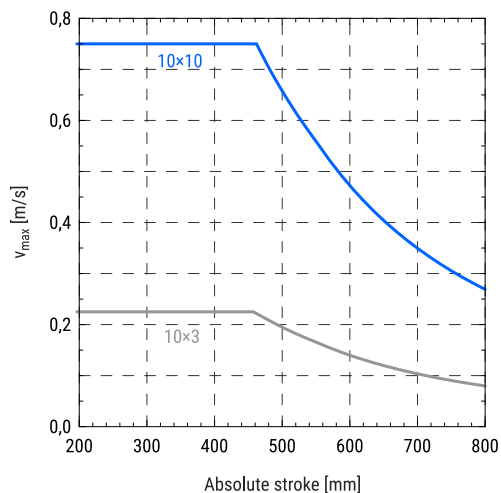

MGBS 60

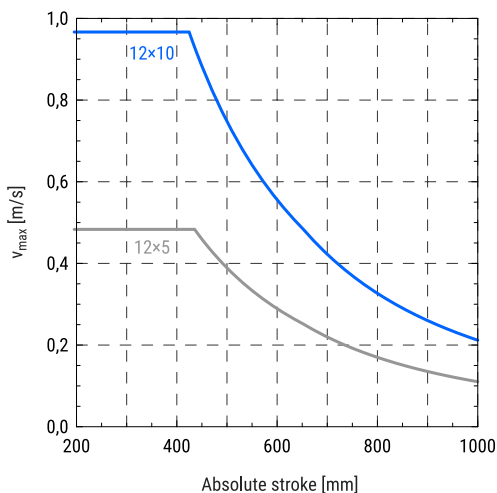

Maximum axial load as a function of absolute stroke

MGBS 32

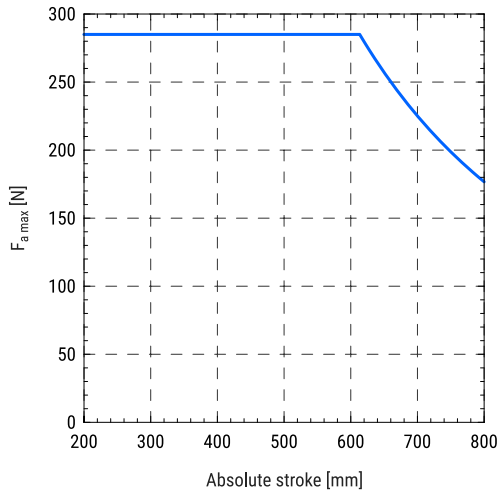

i In the following diagrams, the maximum axial load applied to the carriage of the linear unit as a function of absolute stroke is presented.

MGBS 45

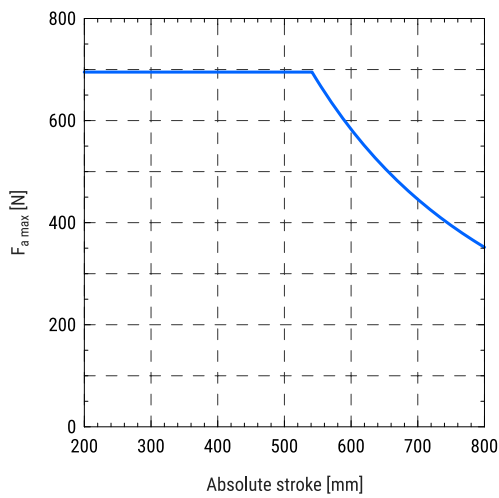

MGBS 60

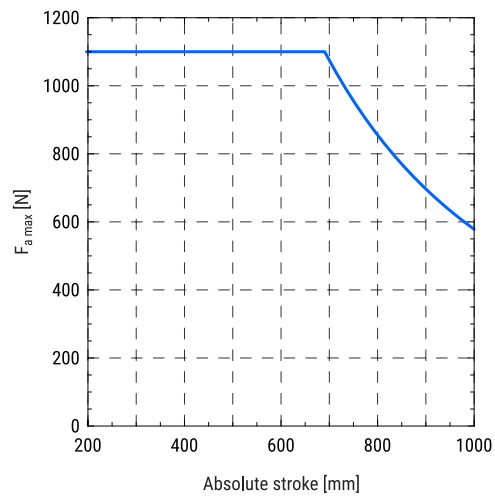

Maximum axial load as a function of the travel speed of the carriage

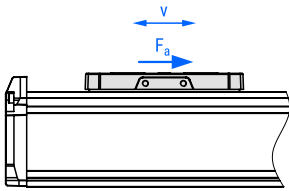

i In the following diagrams, the maximum axial loads applied to the carriage as a function of travel speed for a different values of the absolute stroke are presented.

Values on the curves represent an absolute stroke of the linear unit.

MGBS 32

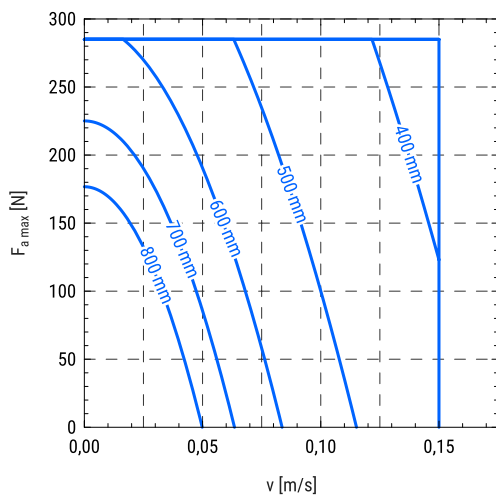

MGBS 45

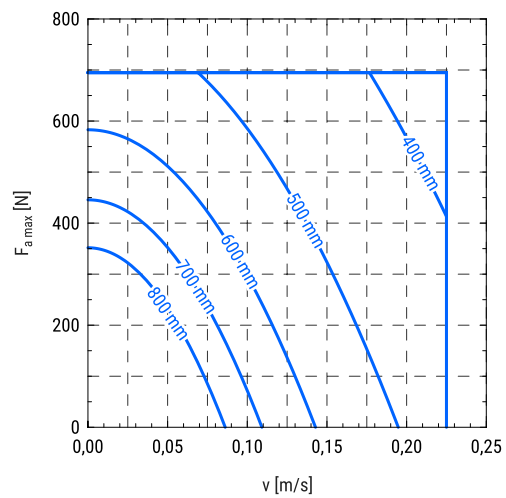

MGBS 60

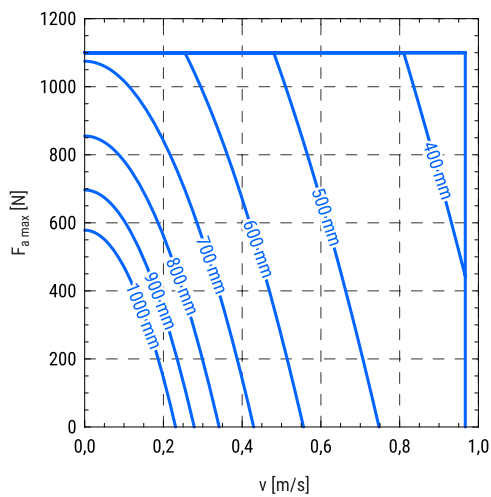

Maximum horizontal payload as a function of the travel speed and acceleration of the carriage

i In the following diagrams, maximum horizontal payloads applied to the carriage as a function of the travel speed for different accelerations, different ball screw leads and different combinations of the standard motors are presented. Motor adapter VK and a motor side drive MSD are also considered.

The diagrams shown below are valid for the linear units with an absolute stroke of 500 mm. Limitations regarding travel speed and axial loads in respect of absolute stroke are not considered and should be taken into account separately.

For more information please refer to the diagrams on pages 16–18.

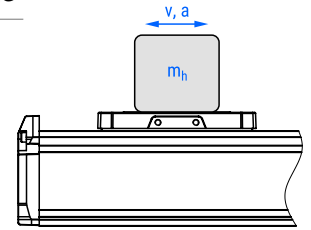

MGBS 32

8 × 2 with a stepper motor □28

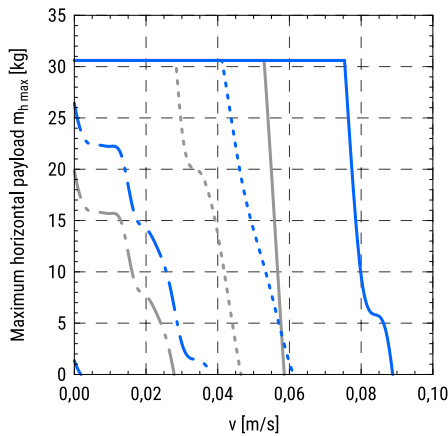

8 × 8 with a stepper motor □28

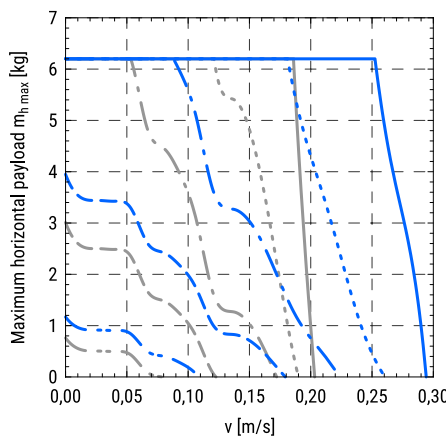

MGBS in combination:

— with VK
— with MSD

Acceleration/Deceleration:

— a = 0,5 m/s²
···· a = 2 m/s²
- - - a = 5 m/s²
- · - a = 10 m/s²
- - - a = 20 m/s²

8 × 2 with a stepper motor □42

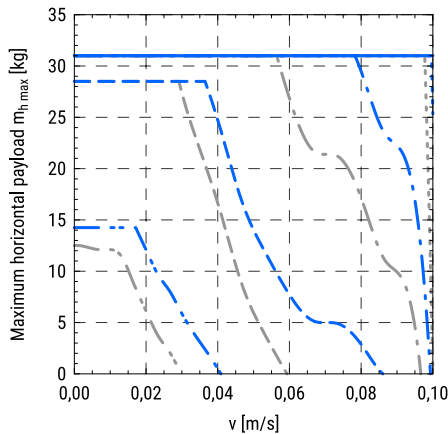

8 × 8 with a stepper motor □42

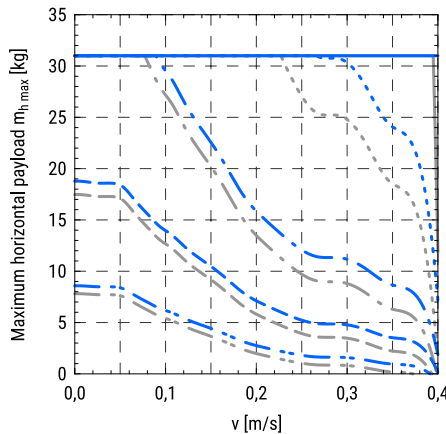

MGBS in combination:

— with VK
— with MSD

Acceleration/Deceleration:

— a = 0,5 m/s²
···· a = 2 m/s²
- - - a = 5 m/s²
- · - a = 10 m/s²
- - - a = 20 m/s²

MGBS 45

10 × 3 with a stepper motor □42

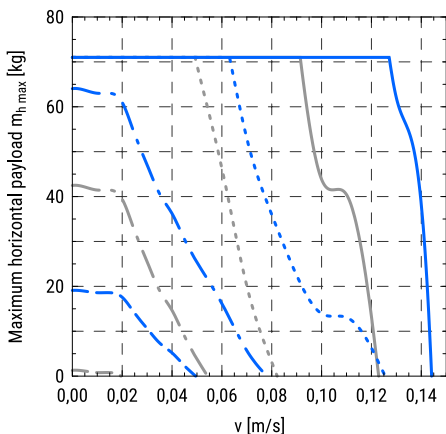

10 × 10 with a stepper motor □42

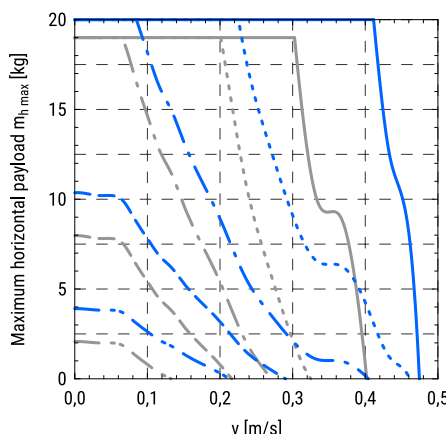

MGBS in combination:

— with VK
— with MSD

Acceleration/Deceleration:

— a = 0,5 m/s²
···· a = 2 m/s²
- - - a = 5 m/s²
- · - a = 10 m/s²
- - - a = 20 m/s²

10 × 3 with a stepper motor □56

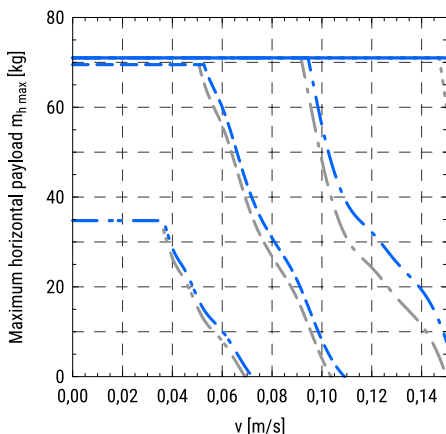

10 × 10 with a stepper motor □56

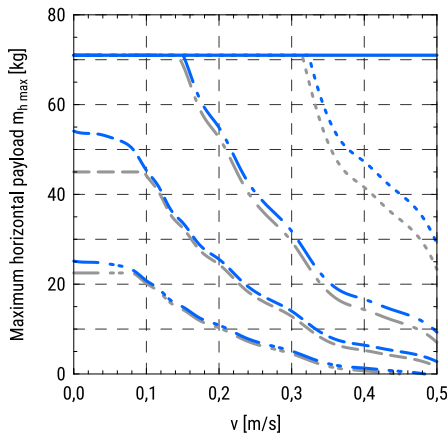

MGBS in combination:
 — with VK
 — with MSD

Acceleration/Deceleration:
 — a = 0,5 m/s²
 - - - a = 2 m/s²
 - - - a = 5 m/s²
 - - - a = 10 m/s²
 - - - a = 20 m/s²

MGBS 60

12 × 5 with a stepper motor □56

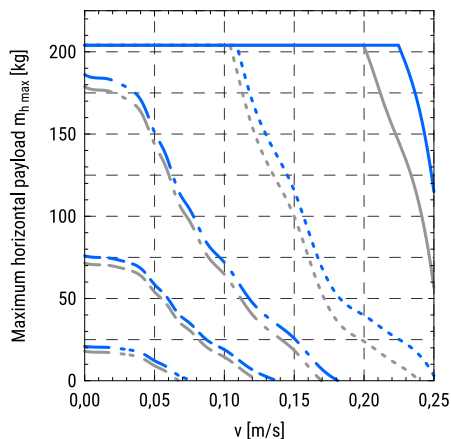

12 × 10 with a stepper motor □56

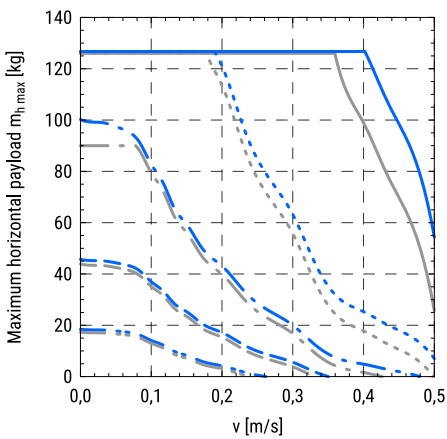

MGBS in combination:
 — with VK
 — with MSD

Acceleration/Deceleration:
 — a = 0,5 m/s²
 - - - a = 2 m/s²
 - - - a = 5 m/s²
 - - - a = 10 m/s²
 - - - a = 20 m/s²

12 × 5 with a stepper motor □86

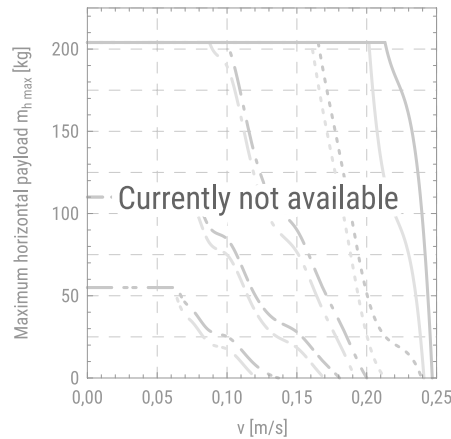

12 × 10 with a stepper motor □86

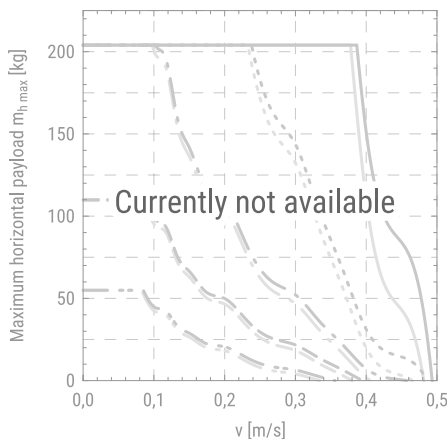

MGBS in combination:
 — with VK
 — with MSD

Acceleration/Deceleration:
 — a = 0,5 m/s²
 - - - a = 2 m/s²
 - - - a = 5 m/s²
 - - - a = 10 m/s²
 - - - a = 20 m/s²

Maximum vertical payload as a function of the travel speed and acceleration of the carriage

i In the following diagrams, maximum vertical payloads applied to the carriage as a function of the travel speed for different accelerations, different ball screw leads and different combinations of the standard motors are presented. Motor adapter VK and a motor side drive MSD are also considered.

The diagrams shown below are valid for the linear units with an absolute stroke of 500 mm. Limitations regarding travel speed and axial loads in respect of absolute stroke are not considered and should be taken into account separately.

For more information please refer to the diagrams on pages 16–18.

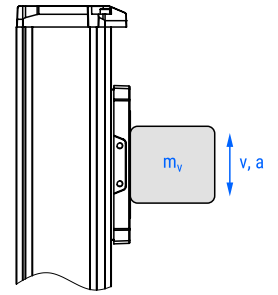

MGBS 32

8 × 2 with a stepper motor □28

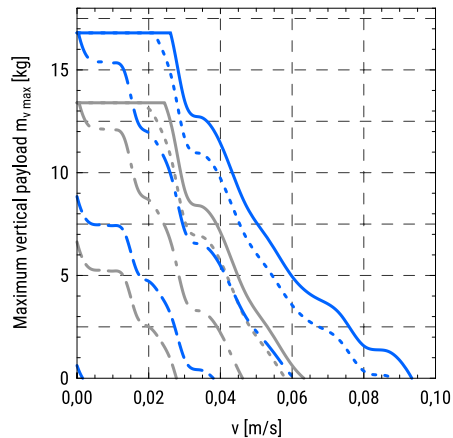

8 × 8 with a stepper motor □28

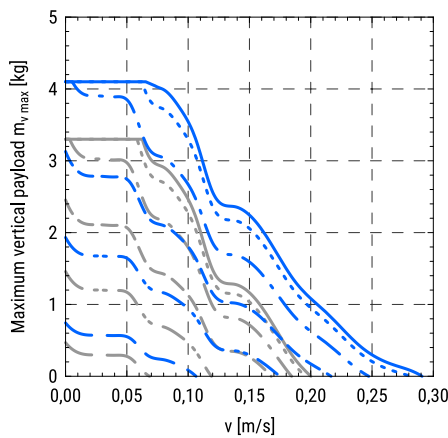

MGBS in combination:
— with VK
— with MSD

Acceleration/Deceleration:
— a = 0 m/s²
- - - a = 0,5 m/s²
- · - a = 2 m/s²
- - - a = 5 m/s²
- · - a = 10 m/s²
- - - a = 20 m/s²

8 × 2 with a stepper motor □42

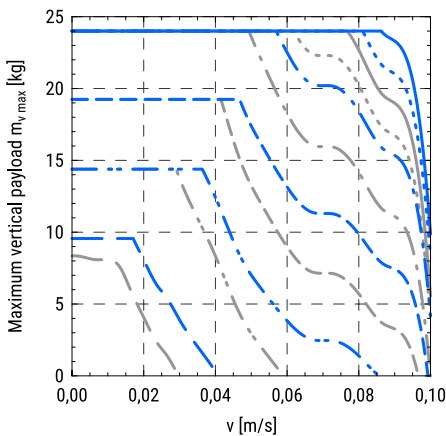

8 × 8 with a stepper motor □42

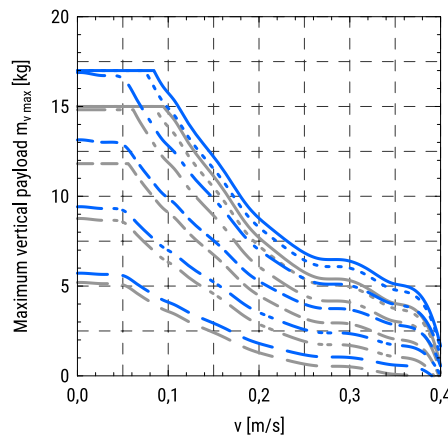

MGBS in combination:
— with VK
— with MSD

Acceleration/Deceleration:
— a = 0 m/s²
- - - a = 0,5 m/s²
- · - a = 2 m/s²
- - - a = 5 m/s²
- · - a = 10 m/s²
- - - a = 20 m/s²

MGBS 45

10 × 3 with a stepper motor □42

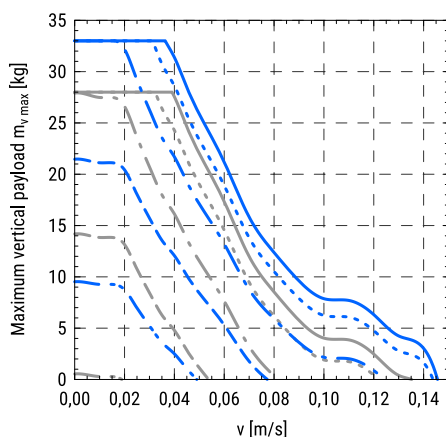

10 × 10 with a stepper motor □42

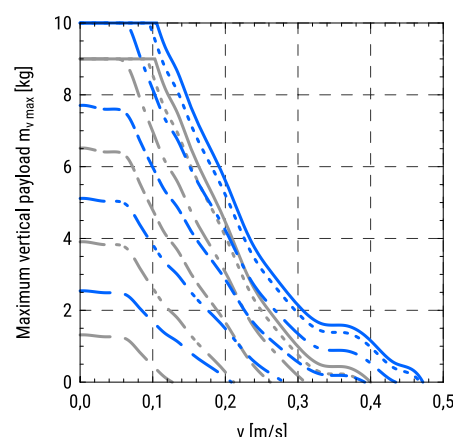

MGBS in combination:
— with VK
— with MSD

Acceleration/Deceleration:
— a = 0 m/s²
- - - a = 0,5 m/s²
- · - a = 2 m/s²
- - - a = 5 m/s²
- · - a = 10 m/s²
- - - a = 20 m/s²

10 × 3 with a stepper motor □56

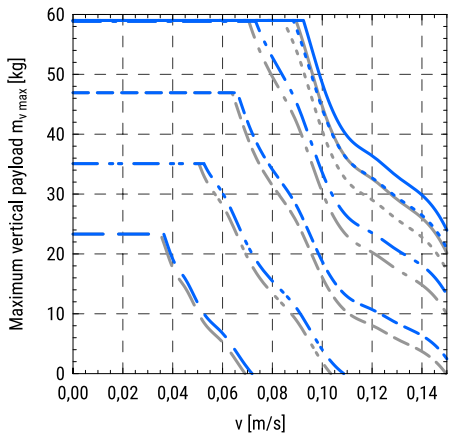

10 × 10 with a stepper motor □56

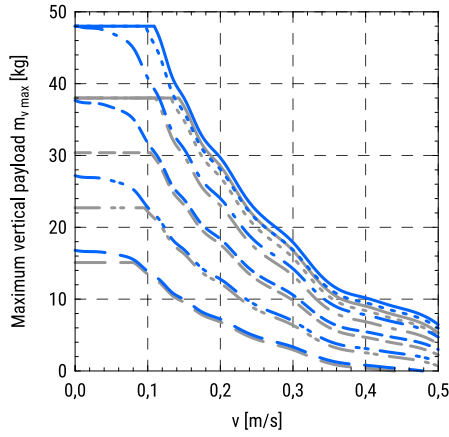

MGBS in combination:
 — with VK
 - - with MSD

Acceleration/Deceleration:
 — a = 0 m/s²
 - - a = 0,5 m/s²
 - - a = 2 m/s²
 - - a = 5 m/s²
 - - a = 10 m/s²
 - - a = 20 m/s²

MGBS 60

12 × 5 with a stepper motor □56

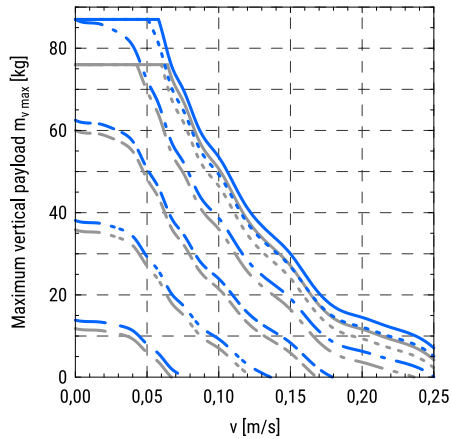

12 × 10 with a stepper motor □56

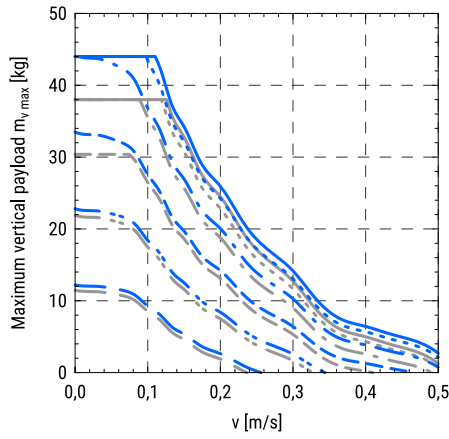

MGBS in combination:
 — with VK
 - - with MSD

Acceleration/Deceleration:
 — a = 0 m/s²
 - - a = 0,5 m/s²
 - - a = 2 m/s²
 - - a = 5 m/s²
 - - a = 10 m/s²
 - - a = 20 m/s²

12 × 5 with a stepper motor □86

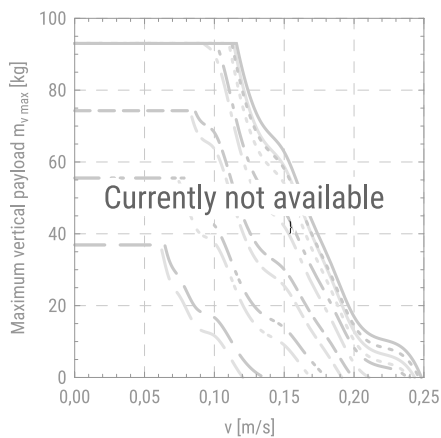

12 × 10 with a stepper motor □86

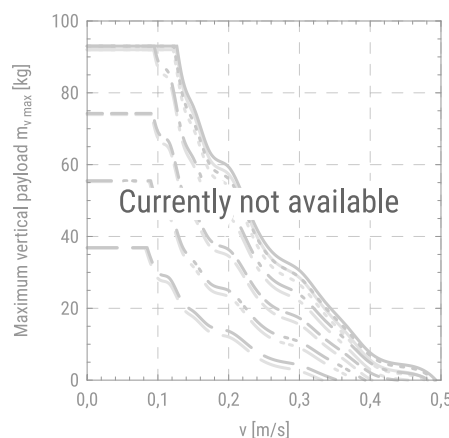

MGBS in combination:
 — with VK
 - - with MSD

Acceleration/Deceleration:
 — a = 0 m/s²
 - - a = 0,5 m/s²
 - - a = 2 m/s²
 - - a = 5 m/s²
 - - a = 10 m/s²
 - - a = 20 m/s²

Maximum axial load as a function of travel speed and acceleration of the carriage

i In the following diagrams, maximum axial load applied to the carriage as a function of the travel speed for different accelerations, different ball screw leads and different combinations of the standard motors is presented. Motor adapter VK and a motor side drive MSD are also considered.

The diagrams shown below are valid for the linear units with an absolute stroke of 500 mm. Limitations regarding travel speed and axial loads in respect of absolute stroke are not considered and should be taken into account separately. For more information please refer to the diagrams on pages 16–18.

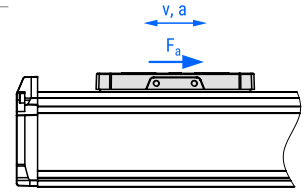

MGBS 32

8 × 2 with a stepper motor □28

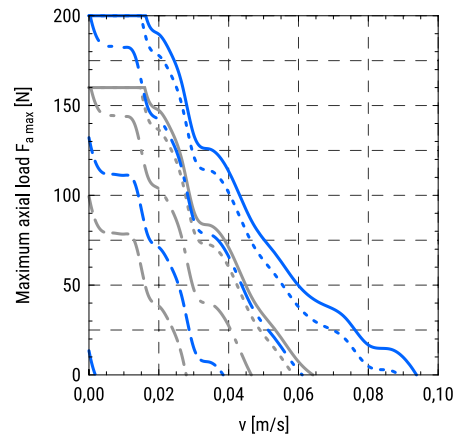

8 × 8 with a stepper motor □28

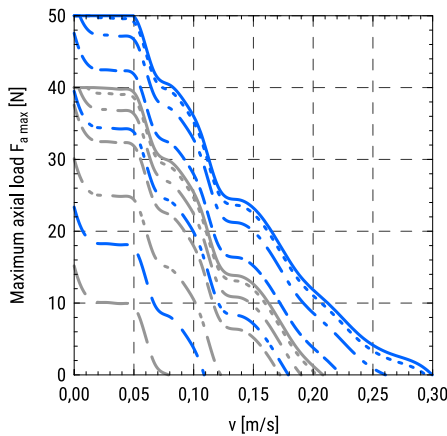

MGBS in combination:
— with VK
- - with MSD

Acceleration/Deceleration:
— $a = 0 \text{ m/s}^2$
- - $a = 0,5 \text{ m/s}^2$
- · - $a = 2 \text{ m/s}^2$
- - - $a = 5 \text{ m/s}^2$
- · · $a = 10 \text{ m/s}^2$
- - - $a = 20 \text{ m/s}^2$

8 × 2 with a stepper motor □42

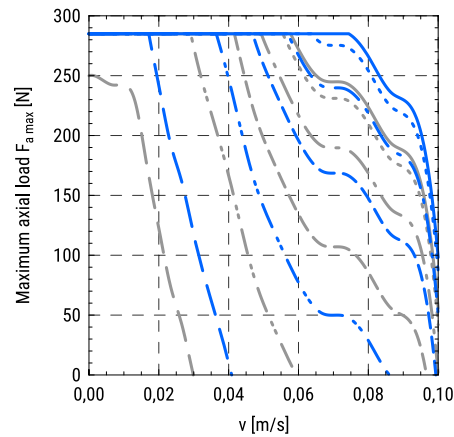

8 × 8 with a stepper motor □42

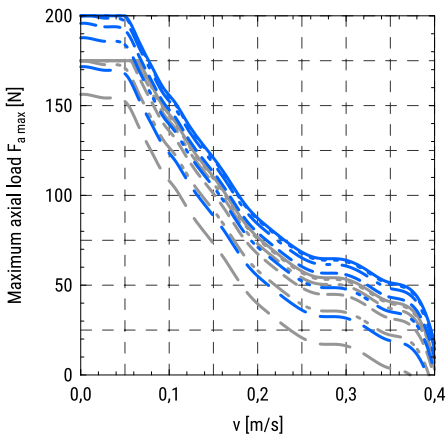

MGBS in combination:
— with VK
- - with MSD

Acceleration/Deceleration:
— $a = 0 \text{ m/s}^2$
- - $a = 0,5 \text{ m/s}^2$
- · - $a = 2 \text{ m/s}^2$
- - - $a = 5 \text{ m/s}^2$
- · · $a = 10 \text{ m/s}^2$
- - - $a = 20 \text{ m/s}^2$

MGBS 45

10 × 3 with a stepper motor □42

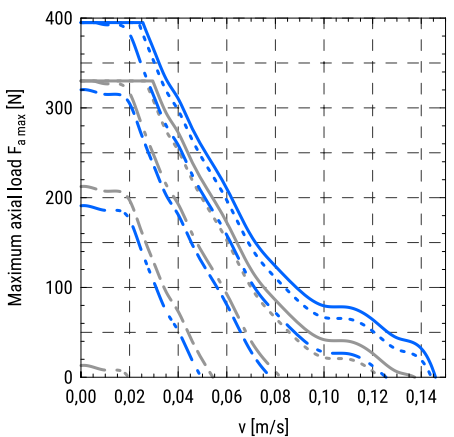

10 × 10 with a stepper motor □42

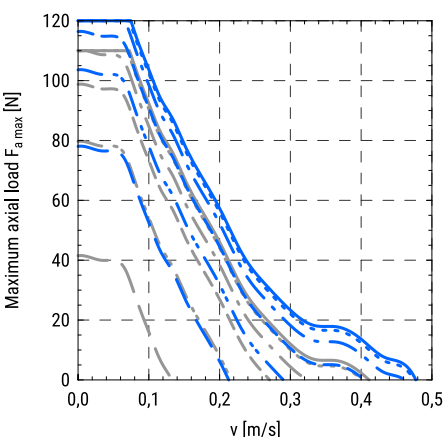

MGBS in combination:
— with VK
- - with MSD

Acceleration/Deceleration:
— $a = 0 \text{ m/s}^2$
- - $a = 0,5 \text{ m/s}^2$
- · - $a = 2 \text{ m/s}^2$
- - - $a = 5 \text{ m/s}^2$
- · · $a = 10 \text{ m/s}^2$
- - - $a = 20 \text{ m/s}^2$

10 × 3 with a stepper motor □56

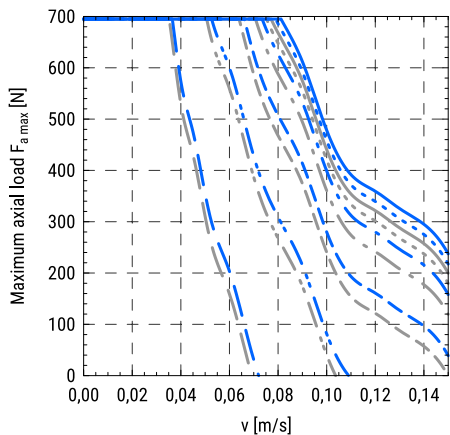

10 × 10 with a stepper motor □56

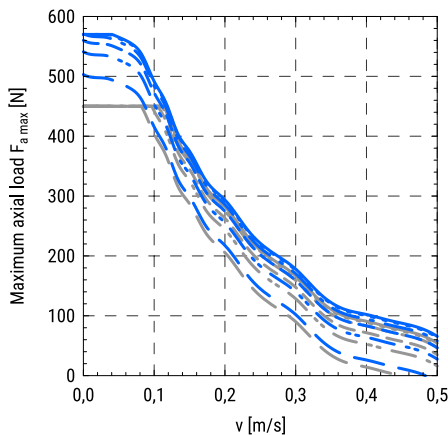

MGBS in combination:
 — with VK
 — with MSD

Acceleration/Deceleration:
 — a = 0 m/s²
 - - - a = 0,5 m/s²
 - - - a = 2 m/s²
 - - - a = 5 m/s²
 - - - a = 10 m/s²
 - - - a = 20 m/s²

MGBS 60

12 × 5 with a stepper motor □56

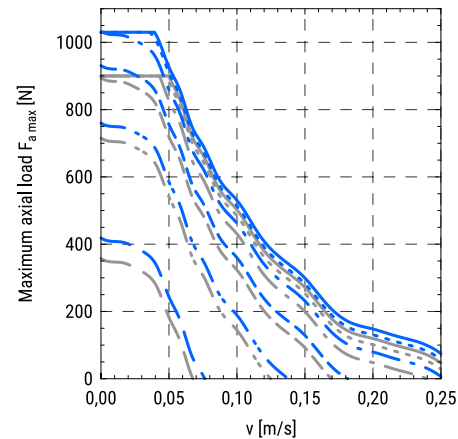

12 × 10 with a stepper motor □56

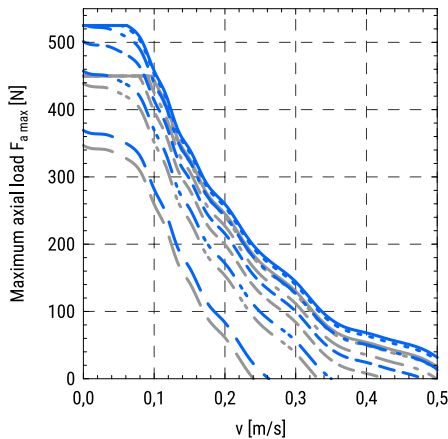

MGBS in combination:
 — with VK
 — with MSD

Acceleration/Deceleration:
 — a = 0 m/s²
 - - - a = 0,5 m/s²
 - - - a = 2 m/s²
 - - - a = 5 m/s²
 - - - a = 10 m/s²
 - - - a = 20 m/s²

12 × 5 with a stepper motor □86

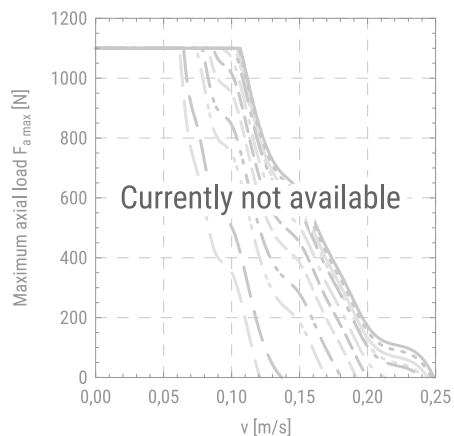

12 × 10 with a stepper motor □86

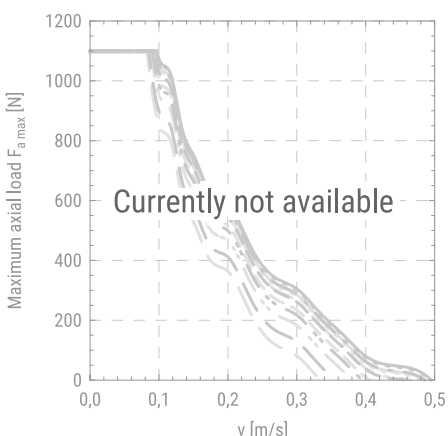

MGBS in combination:
 — with VK
 — with MSD

Acceleration/Deceleration:
 — a = 0 m/s²
 - - - a = 0,5 m/s²
 - - - a = 2 m/s²
 - - - a = 5 m/s²
 - - - a = 10 m/s²
 - - - a = 20 m/s²

Maximum horizontal payload as a function of position change and positioning time of the carriage

i The following diagrams show the maximum payload that can be moved by a certain horizontal distance within a positioning time frame. Acceleration/deceleration time of 100 ms is taken into account.

Diagrams depend on the ball screw leads and different combinations of the standard motors. Motor adapter VK and a motor side drive MSD are also considered

The diagrams shown below are valid for the linear units with an absolute stroke of 500 mm. Limitations regarding travel speed and axial loads in respect of absolute stroke are not considered and should be taken into account separately.

For more information please refer to the diagrams on pages 16–18.

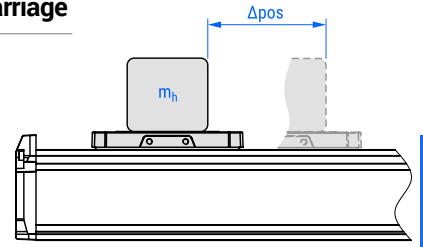

MGBS 32

8 × 2 with a stepper motor □28

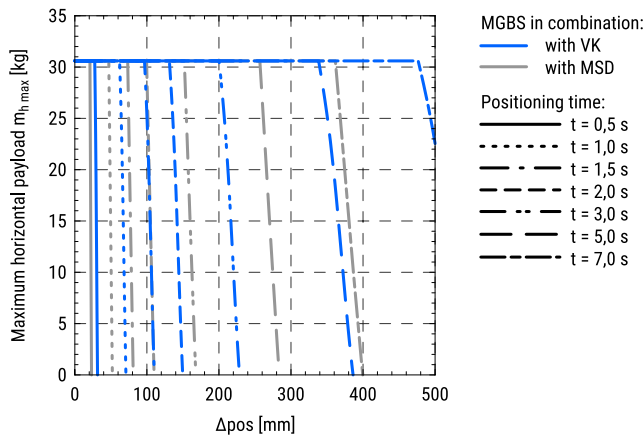

8 × 8 with a stepper motor □28

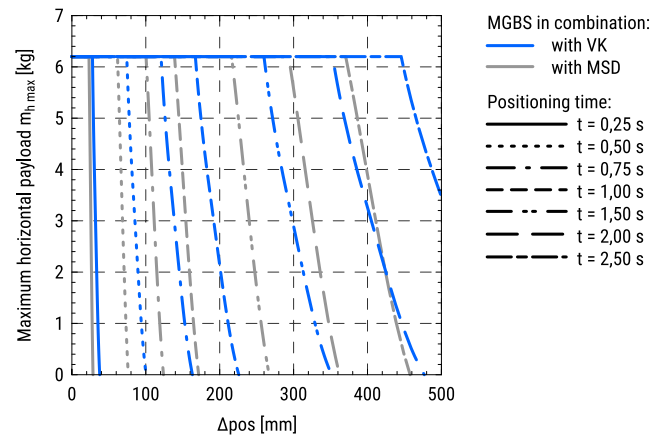

8 × 2 with a stepper motor □42

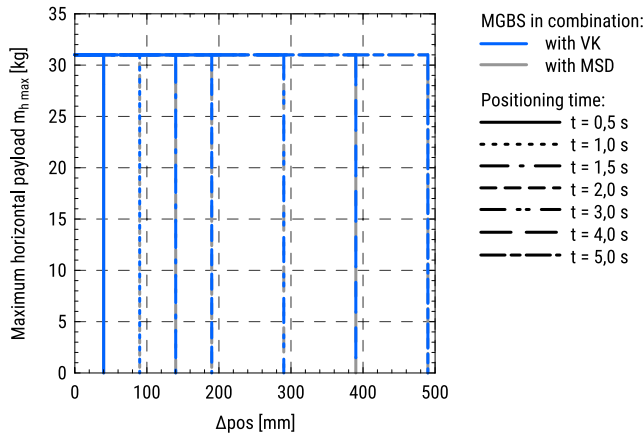

8 × 8 with a stepper motor □42

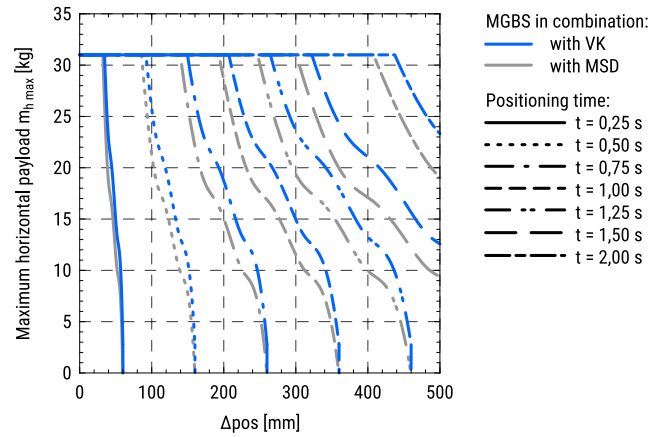

MGBS 45

10 × 3 with a stepper motor □42

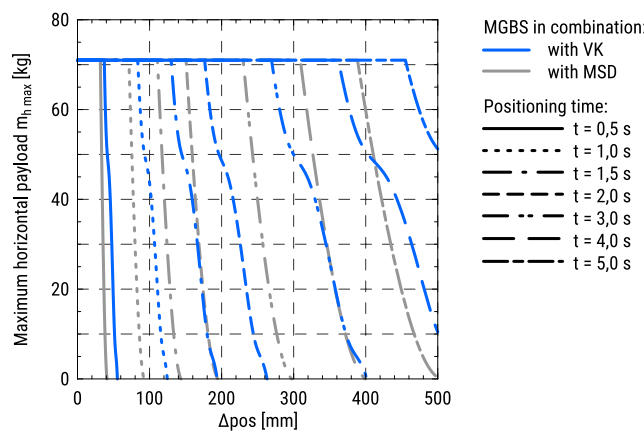

10 × 10 with a stepper motor □42

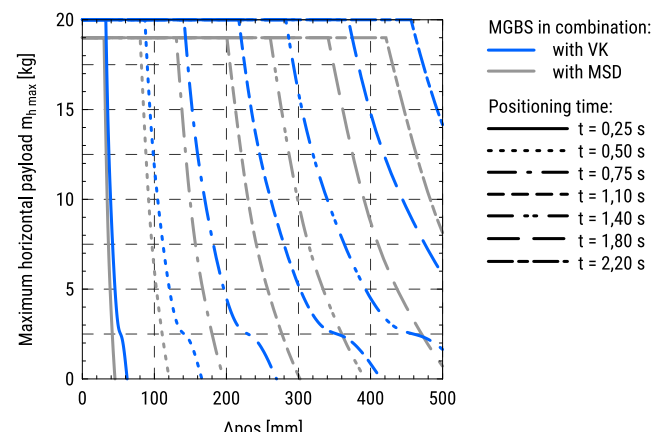

10 × 3 with a stepper motor □56

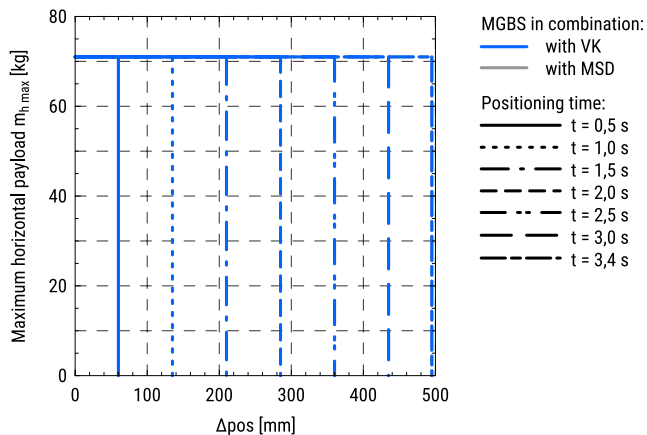

10 × 10 with a stepper motor □56

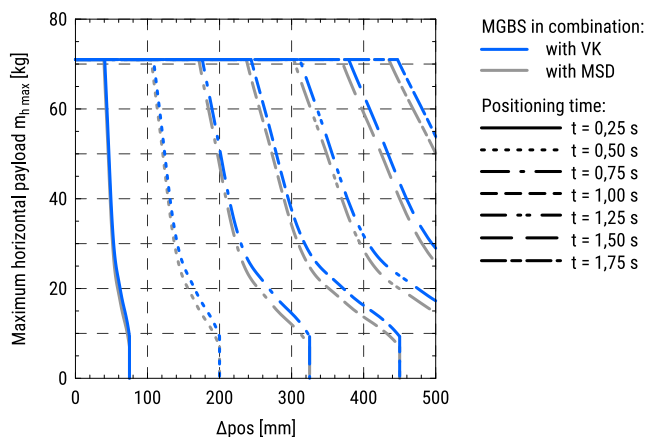

MGBS 60

12 × 5 with a stepper motor □56

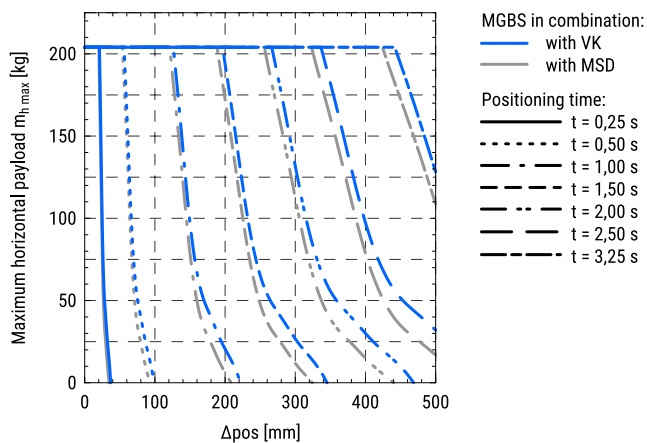

12 × 10 with a stepper motor □56

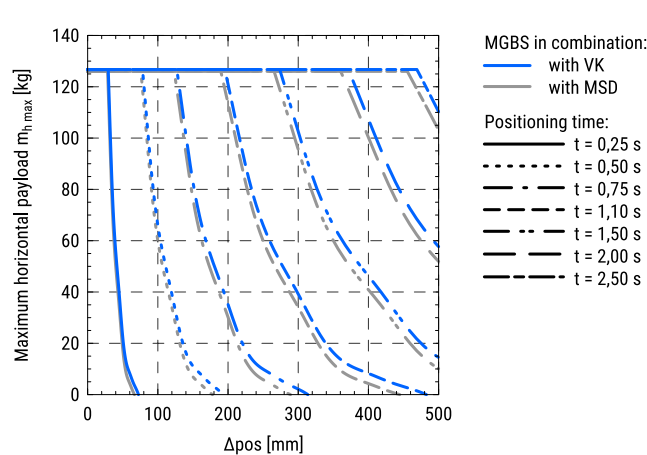

12 × 5 with a stepper motor □86

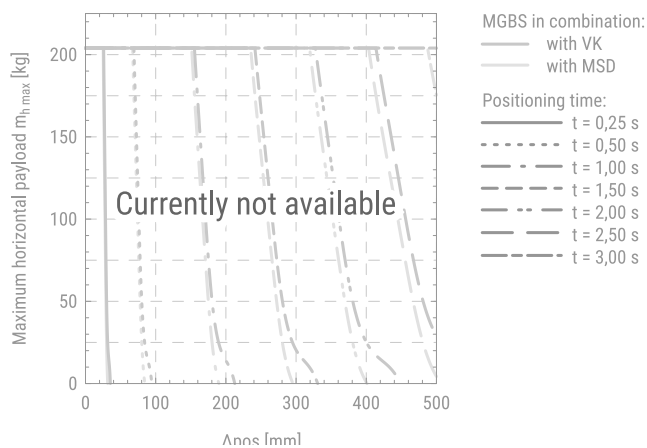

12 × 10 with a stepper motor □86

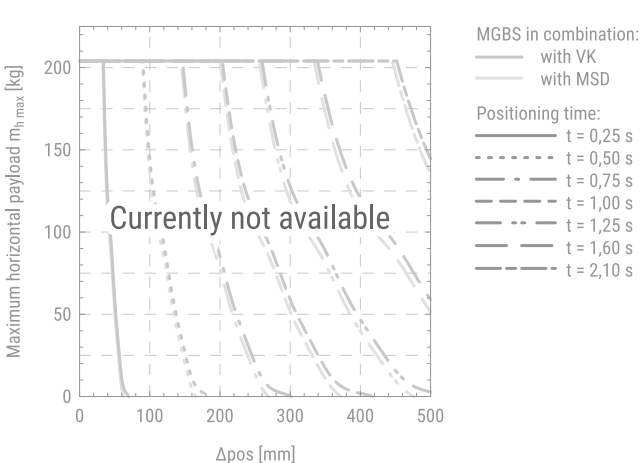

Maximum vertical payload as a function of position change and positioning time of the carriage

i The following diagrams show the maximum payload that can be moved by a certain vertical distance in a positioning time frame. Acceleration/deceleration time of 100 ms is taken into account.

Diagrams depend on the ball screw leads and combinations of standard motors. Motor adapter VK and a motor side drive MSD are also considered.

The diagrams shown below are valid for the linear units with an absolute stroke of 500 mm. Limitations regarding travel speed and axial loads in respect of absolute stroke are not considered and should be taken into account separately.

For more information please refer to the diagrams on pages 16–18.

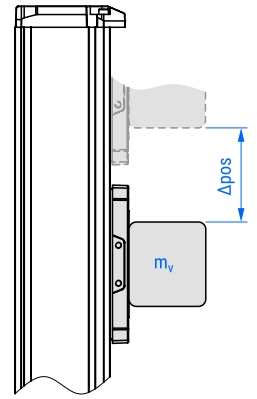

MGBS 32

8 × 2 with a stepper motor □28

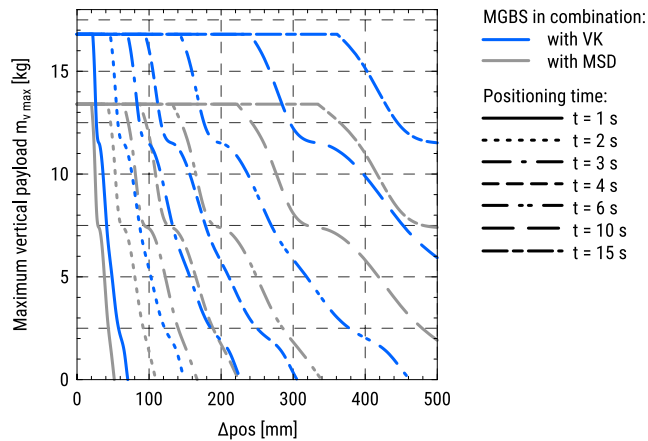

8 × 8 with a stepper motor □28

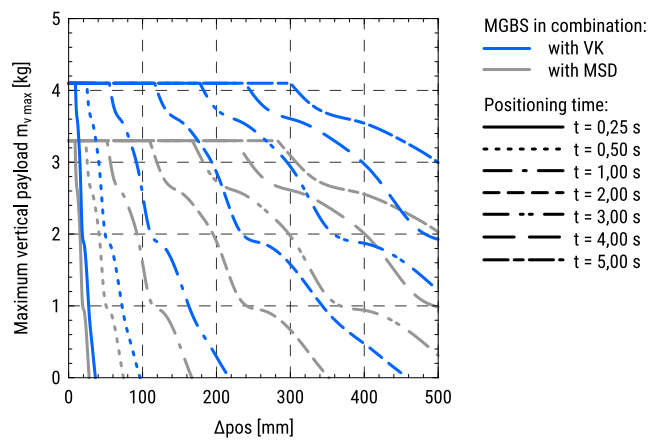

8 × 2 with a stepper motor □42

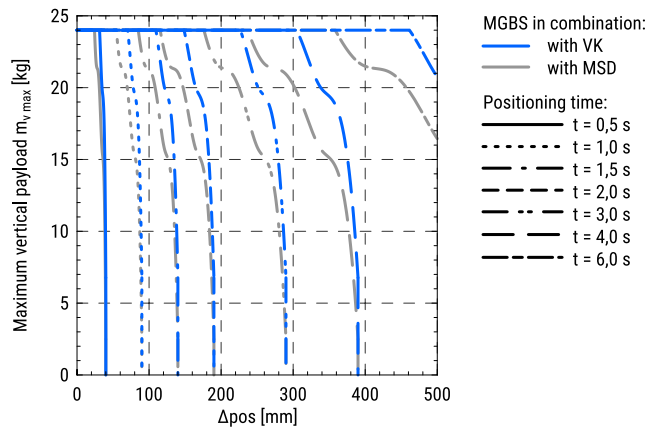

8 × 8 with a stepper motor □42

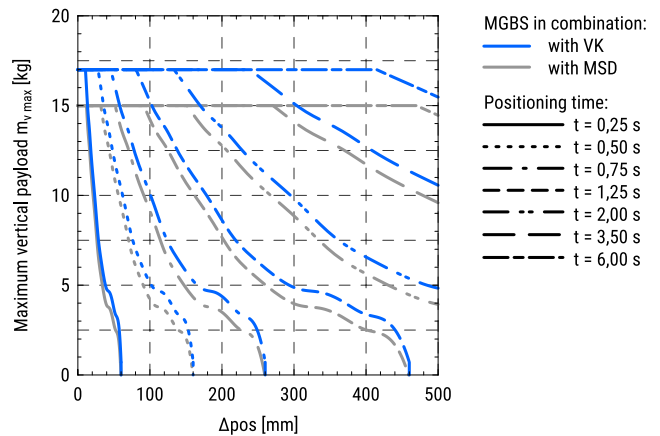

MGBS 45

10 × 3 with a stepper motor □42

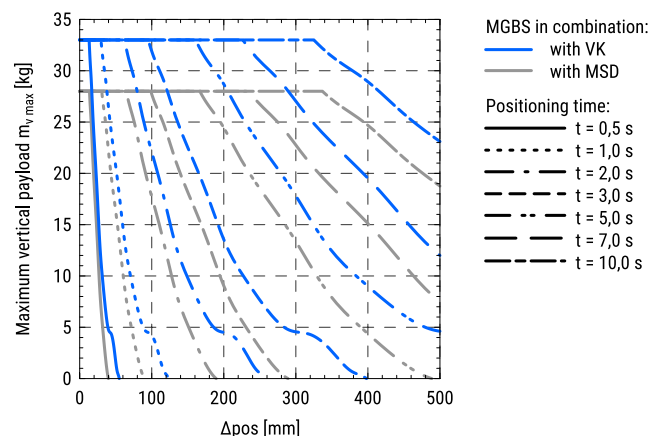

10 × 10 with a stepper motor □42

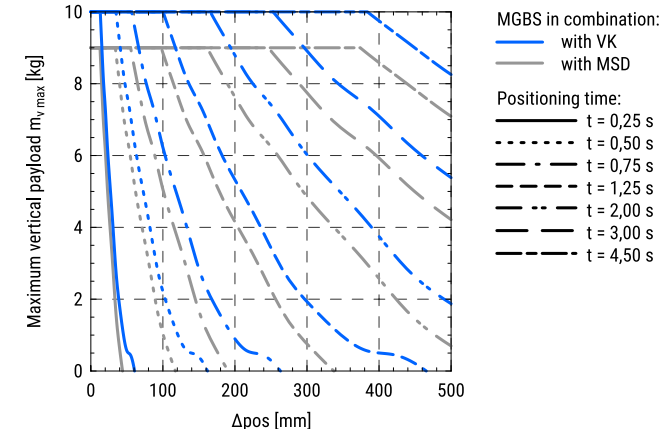

10 × 3 with a stepper motor □56

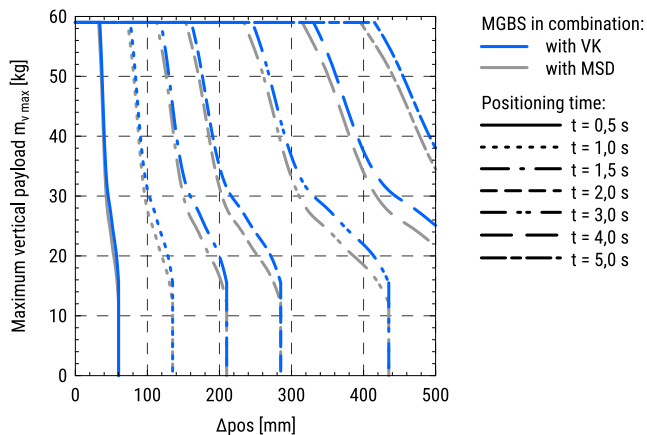

10 × 10 with a stepper motor □56

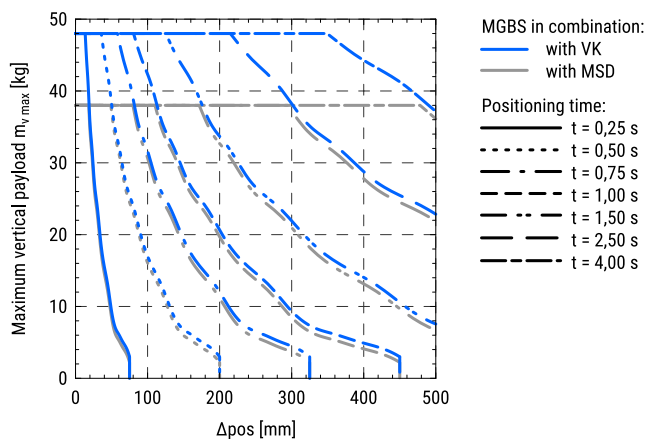

MGBS 60

12 × 5 with a stepper motor □56

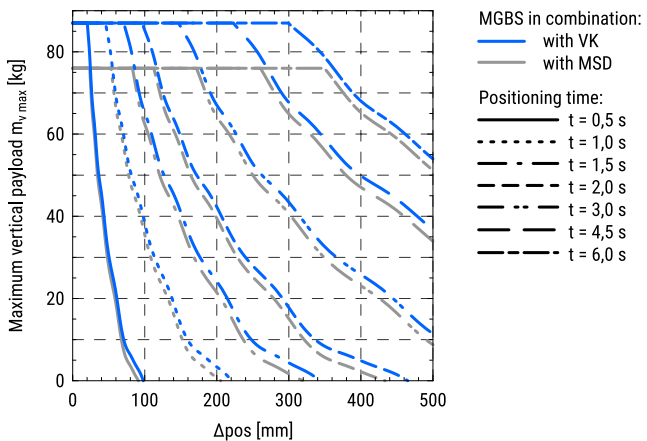

12 × 10 with a stepper motor □56

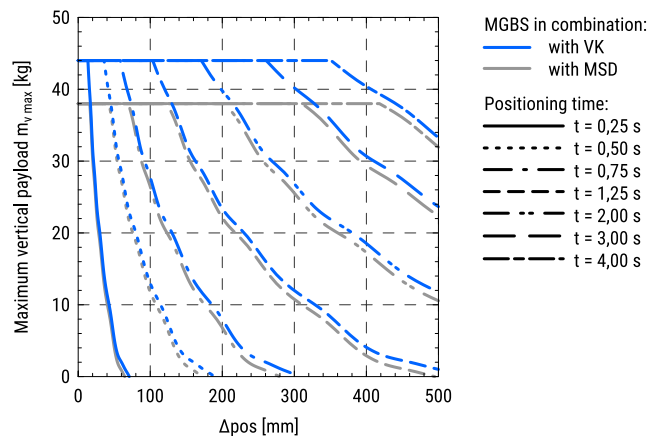

12 × 5 with a stepper motor □86

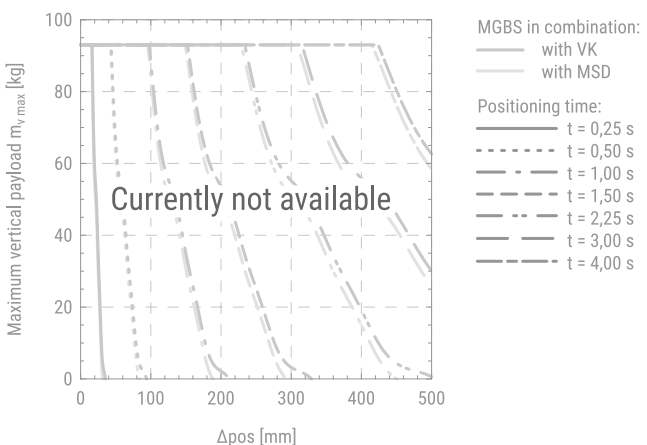

12 × 10 with a stepper motor □86

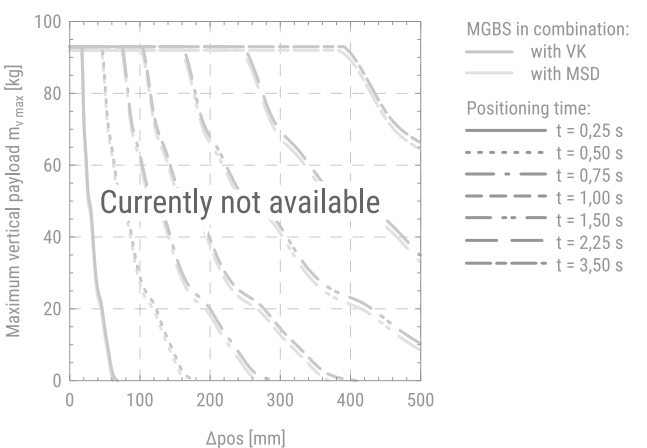

DIMENSIONS

i All dimensions are in mm. The scale of the drawings may not be equal.

MGBS in combination with a standard motor and a motor adapter VK

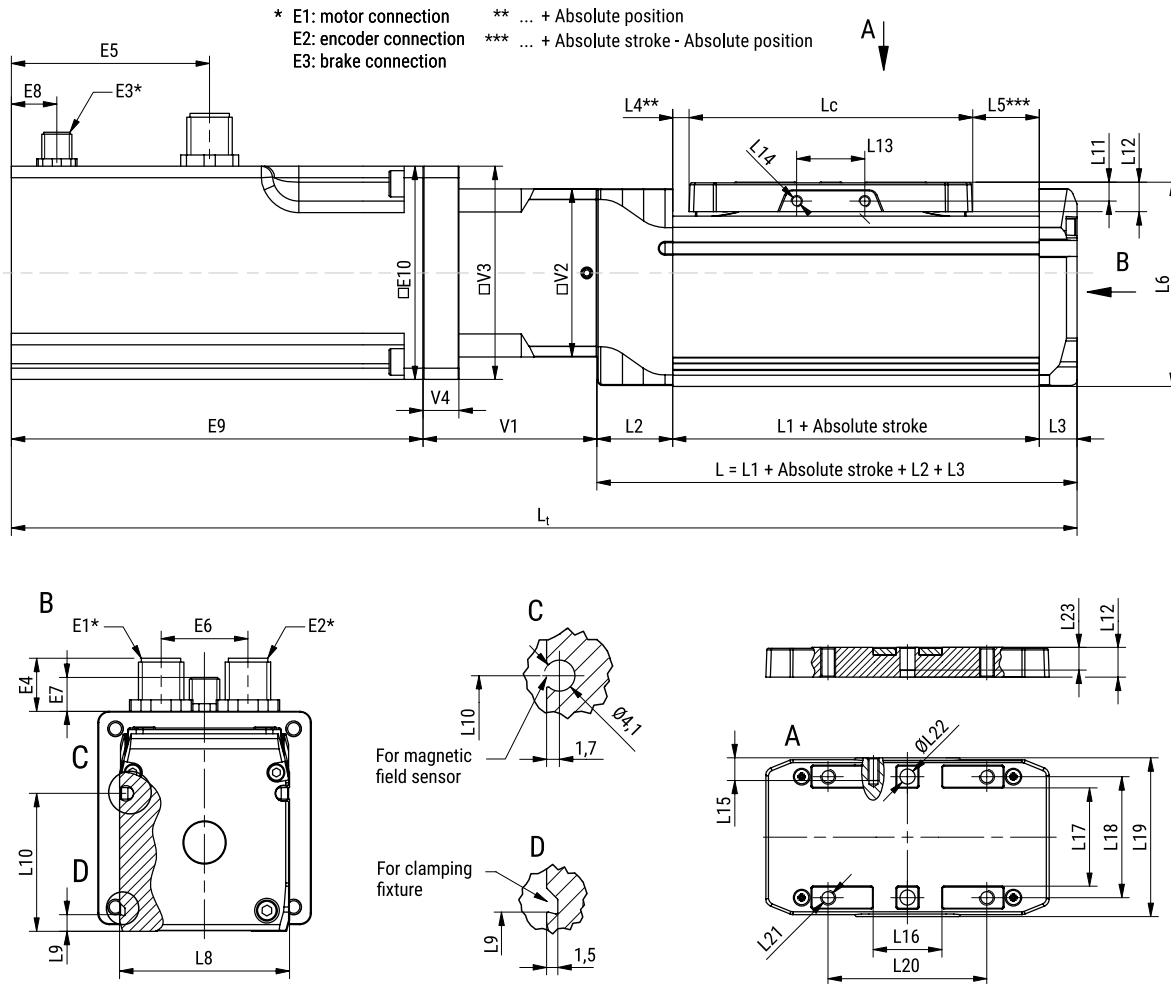

MGBS in combination with a standard motor and a motor side drive MSD

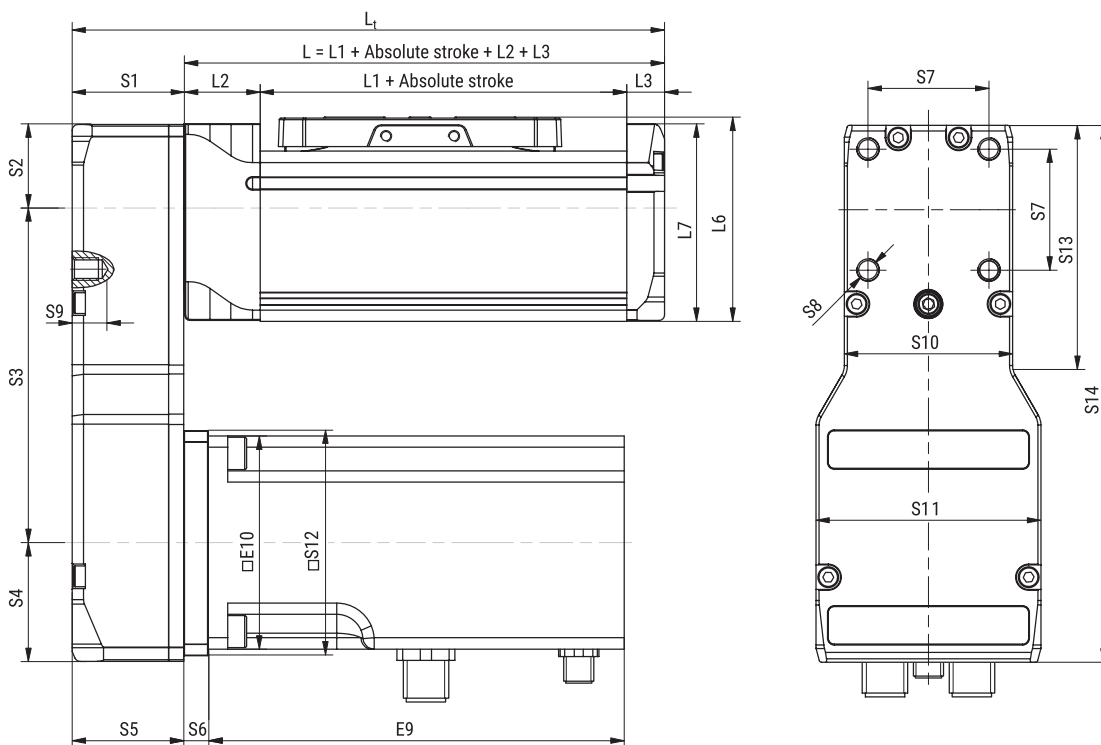

MGBS without a motor

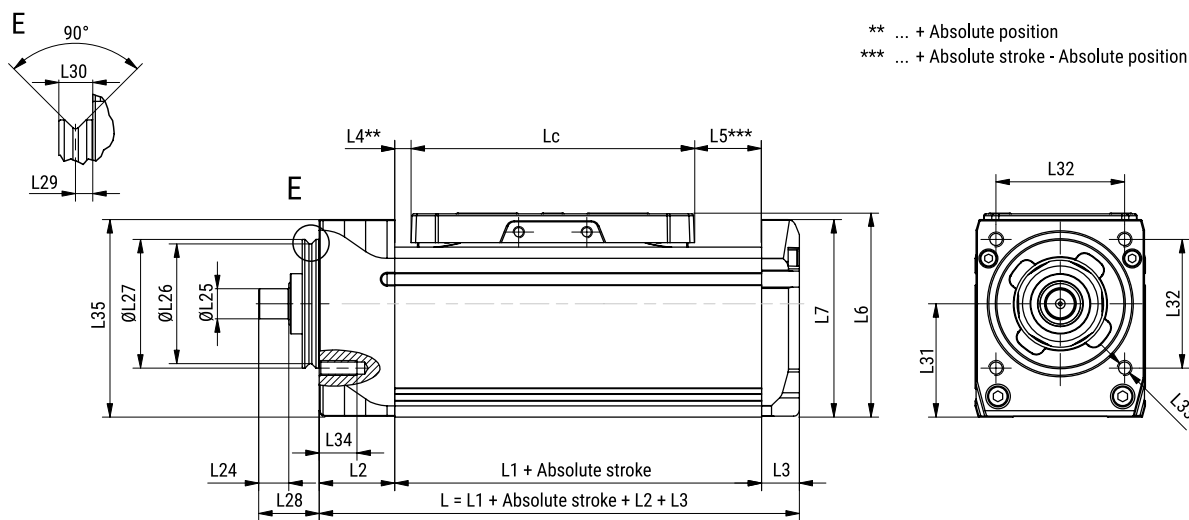

MGBS dimensions

MGBS	Lc	L1	L2	L3	L4	L5	L6	L7	L8	L9	L10	L11	L12	L13	L14	L15	L16	L17	L18	L19	L20	L21	ØL22 (H7)
32	65	81,5	16	8	2,5	14	38,5	35,75	32	4,4	23,7	4	5,9	18	M2	4	14,6	18,4	22,5	30	35	M3	2
45	75	97	20	10	4,3	17,7	54	52,25	45	4,4	36,5	5	7,8	18	M3	6	18,6	26,4	32	42	42	M4	4
60	90	133	24	12	3,2	39,8	72	68,75	60	4,4	45	6	11	30	M4	6	25,4	38,4	45	57	55	M5	5

MGBS	L23	L24	ØL25 (h7)	ØL26	ØL27 (h7)	L28	L29	L30	L31	L32	L33	L34	L35
32	5	7	5	22,6	25	14	2,3	4,5	20	24,5	M3	6	35,75
45	6	8	8	31,6	34	16	2,3	4,5	30	34	M4	10	52,25
60	8	10	10	39,6	42	20	2,3	4,5	39	48	M5	10	68,75

Motor adapter VK and a motor side drive MSD dimensions

MGBS	Motor		V1	□V2	□V3	V4	S1	S2	S3 (±0,5)	S4	S5	S6	S7	S8	S9	S10	S11	S12	S13	S14
	Type	Size □ [mm]																		
32	Stepper	28	36	31,5	31,5	0	22	15,75	52,5	17,25	22	4	22	M5	6	31,5	31,5	44,5	0	85,5
		42	40	31,5	42	5,5	22	15,75	70,5	23,75	22	4,5	22	M5	6,5	31,5	44,5	44,5	48	110
45	Stepper	42	42	44,5	44,5	0	27,5	22,25	81	23,75	27,5	4,5	32	M6	8,5	44,5	44,5	59,5	0	127
		56	46	44,5	56,4	9,5	27,5	22,25	88,5	31,25	27,5	6,5	32	M6	8,5	44,5	59,5	59,5	63,5	142
60	Stepper	56	52,5	59,5	59,5	0	33	29,75	96	31,25	33	6,5	38	M6	8	59,5	59,5	85,5	0	157
		86	69	59,5	86	9,5	33	29,75	121,5	44,25	33	8,5	38	M6	8	59,5	85,5	86,5	81,5	195,5

Motor dimensions

Type	Motor		E1	E2	E3	E4 (±1)	E5 (±0,3)	E6	E7 (±1)	E8 (±0,3)	E9 (±1)	□ E10
	Size □ [mm]	Brake										
Stepper	28	–	Currently not available									
	28	with	Currently not available									
	42	–	M12 5-pole	M12 8-pole	–	14	14	19,5	–	–	70,4	42,3
	42	with	M12 5-pole	M12 8-pole	M8 3-pole	14	14	19,5	9	27	106,4	42,3
	56	–	M12 5-pole	M12 8-pole	–	14	13,4	23	–	–	98	56,4
	56	with	M12 5-pole	M12 8-pole	M8 3-pole	14	52,4	23	9	12	138	56,4
	86	–	Currently not available									
	86	with	Currently not available									

Absolute stroke of the MGBS definition

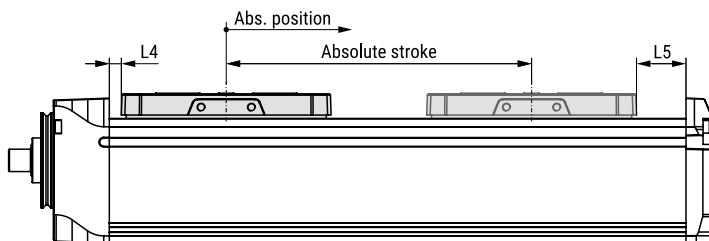

i Dimensions L4 and L5 are presented in the dimensional drawing table above.

Absolute stroke definition

Absolute stroke = Effective stroke + 2 × Safety stroke

i Mini linear unit MGBS does not include any safety stroke.

The absolute stroke is the distance between the two positions of the carriage that are as far apart as it is physically possible.

Length definition

With VK and a motor:

$$L_t = L + E9 + V1$$

With MSD and a motor:

$$L_t = L + S1$$

Without a motor:

$$L_t = L$$

$$L = L1 + \text{Abs. stroke} + L2 + L3$$

i Lengths L and L_t are defined as it is presented in the dimensional drawings above, where the lengths of the motor, motor adapter VK and motor side drive MSD are also considered.

Abs. stroke	Absolute stroke	[mm]
Abs. position	Absolute position	[mm]
L	Length	[mm]
L_t	Total length	[mm]

ACCESSORIES

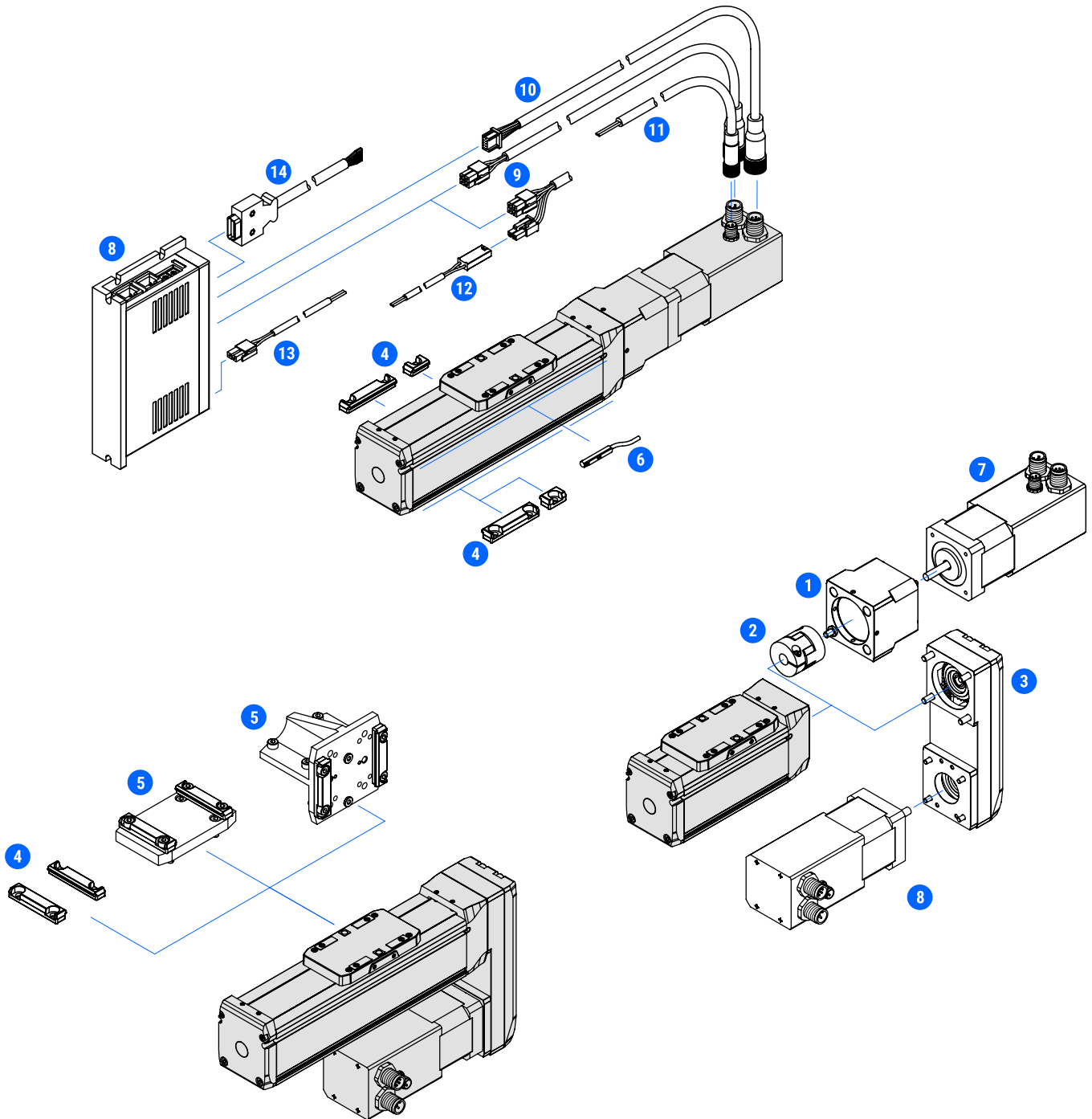

ACCESSORIES

#	Accessories	Compatible with MGBS size			Page	
		32	45	60		
1	Motor adapter VK	•	•	•	59	Motor adapters
2	Coupling	•	•	•	60	Elastomer couplings
3	Motor side drive MSD	•	•	•	61	Motor side drives
4	Clamping fixture	•	•	•	63	Mounting attachment
5	Connection plate	•	•	•	64	
6	Magnetic field sensor	•	•	•	66	Limit switches
7	Motor	•	•	•	67	Motors
8	Drive	•	•	•	68	Drives
9	Motor cable ¹	• ¹	•	•	69	Cables
10	Encoder cable	•	•	•	69	
11	Brake cable ¹	• ¹	•	•	69	
12	Brake to terminal cable ¹	•	—	—	69	
13	Power cable	•	•	•	71	
14	Signal cable	•	•	•	71	

¹ For the stepper motor size of 28, the motor and brake cables are combined into one cable.
For connectivity between the brake and terminal, an additional brake to terminal cable is used