

Senix ToughSonic® CHEM 10 Level Sensor

Read Liquids or Solids in Chemically Aggressive Environments

LVL-100 Series

CHEM series sensors and SenixVIEW software put the power of ultrasonics in your hands. Adjust, optimize, save and clone your applications quickly without calibration!

These sensors are contained in a rugged, chemically inert PVDF sealed housing for long life. They mount above the material surface and measure distance downward without contact. All outputs respond simultaneously to the measured distance.

Applications include pump control, bulk inventory, flumes/weirs, batch processing, water management and high/low level alarms.

**Non-Contact
Ultrasonic
Distance & Level
Measurement**

TOUGHSONIC®
Tough. Smart. Connected.

Features

Level Measurement

- Long and short measurement
- Temperature compensation
- Unaffected by liquid color, density and transparency
- Remotely adjustable via PC

Packaging & Performance

- Durable housing for long life
- Top and bottom thread mounts
- Short & overload protected I/O
- Adjustable filters compensate for tank mixers or turbulence
- Adjustable sensitivity

Functionality Beyond Sensing

Adjustable interface features like switch hysteresis and time delays offer solutions for basic level alarms and pump controls without additional hardware.



PC Setup Power!

Use SenixVIEW software (see separate data sheet) to adjust all sensor features. View, analyze or log data to optimize your application. Setups are unaffected by power interruption.

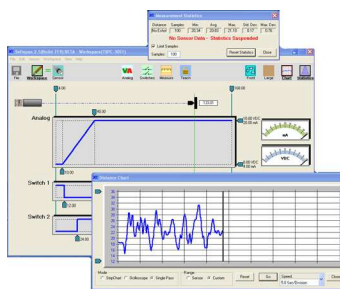

Copy without Calibration

Application setups can be saved for future recall. From a single sensor inventory part you can quickly clone sensors, without recalibration, for any number of different field installations.

Connections

Serial Data Interface

Used for SenixVIEW setup or user device communication. Choose RS-232 or RS-485 by model.

Analog Outputs (3)

Includes voltage (0-10 VDC) and two current loops (4-20 mA sinking and sourcing). Both output types have user-selectable voltage/current ranges and endpoints for best resolution. The output slope is easily inverted.

Switches (2)

Each switch is SenixVIEW configurable as "PNP" or "NPN" type (sourcing or sinking), with adjustable set point, hysteresis, window, initial conditions, ON delay, OFF delay and loss of target response. These are commonly used for level controls and alarms.

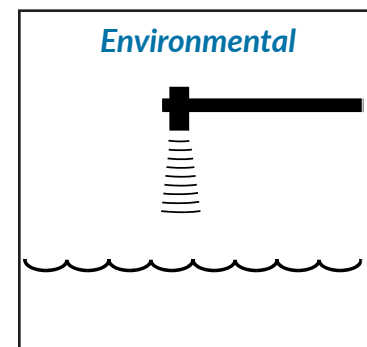
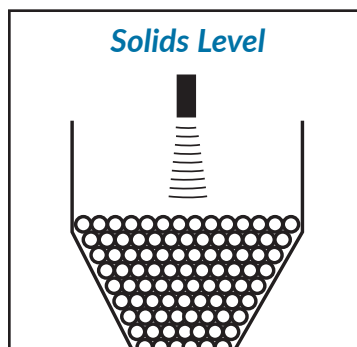
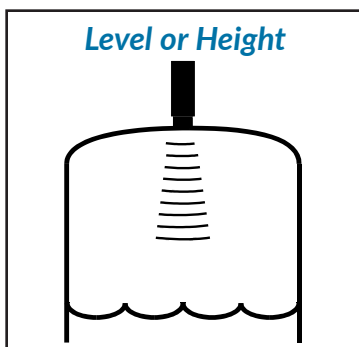



ToughSonic® CHEM 10 Level Sensor

Specifications

Optimum Range	80 in. (2 m)	Max Range	10 ft. (3 m)
Deadband	Typ. < 4 in. (100 mm)	Adjustment	SenixVIEW software
Case Material	PVDF	Configuration	Stored in non-volatile memory
Temperature	-40 to 158 F (-40 to 70 C)	Outputs	Five selectable, plus serial data
Humidity	0 to 100% operating	Transducer	Rugged piezoelectric
Compensation	Temperature compensated	Protection	NEMA-4X, NEMA-6P, IP68
Resolution	Digital: 0.0034 in. (0.086 mm); Analog: 4099 steps (0-10 VDC), 3279 steps (4-20 mA)		
Repeatability	Greater of +/-0.03 in. (0.76 mm) or 0.2% of target distance in stable environment		
Update Rate	20 Hz (50 ms), SenixVIEW adjustable; affected by SenixVIEW filter selections		
Input Power	10-30 VDC, 50 mA maximum (not including output currents)		
Voltage Output	0-10, 0-5 VDC or PC customized; 10 mA max. (*)		
Current Loop #1	Current sourcing 4-20 mA or PC customized, max. loop 450Ω (*)		
Current Loop #2	Current sinking 4-20 mA or PC customized, max. loop 450Ω (*)		
Sinking Switch	150 mA max. @ 40 VDC max., teachable set point & polarity, fault indication		
Sourcing Switch	150 mA max. @ input voltage, teachable set point & polarity, fault indication		
RS-232, RS-485	Modbus protocol, 9600-115200 baud (selectable), 8 data bits, 1 stop, no parity		
Target Requirements			
Target	Detects flat or irregular surfaces. Target surface must reflect sound back to sensor.		
Max. Distance	Affected by size, shape, orientation of target (sound level reflected back to sensor), environment Restrict use to Optimum Range when using over a wide range of environmental conditions		
Granular Solids	De-rate max range by 50%; range affected by material density and orientation		
Orientation	Orient sensor beam perpendicular to target surface for best performance		

Connections

Cable Connection	Wire	Description
Power	Brown	10-30 VDC, 50 mA maximum; Typical: 45 mA @ 24 VDC (**)
Ground	Blue	Power and interface common
Voltage Output *	Violet	0-10 VDC, 0-5 VDC or custom end values between 0 and 10 VDC
Current Loop Output *	Green	4-20 mA sourcing (adjustable end values between 4 and 20 mA)
Current Loop Output *	Orange	4-20 mA sinking (adjustable end values between 4 and 20 mA)
Switch #1 Output	Black	Sinking ("NPN") or Sourcing ("PNP"), user selected
Switch #2 Output	White	Sinking ("NPN") or Sourcing ("PNP"), user selected
RS-232 out / RS-485-	Gray	Serial data connection (depends on model - see model selection)
RS-232 in / RS-485+	Yellow	Serial data connection (depends on model - see model selection)

(*) Analog outputs share common distance endpoints. Both 4-20 mA outputs share the same adjustable max / min values. The maximum loop resistance is derated below 15 VDC input voltage.

(**) At default update rate. Output currents not included. Sensitivity reduced below 15 VDC input voltage.

Part Numbers

Model Number	Description
LVL-100-232	RS-232 serial data interface
LVL-100-485	RS-485 serial data interface (allows addressable multi-sensor networks)

Senix offers additional interconnection, communication, mounting and display components.
We also offer special assembly options for OEM customers to suit specific needs.

Dimensions

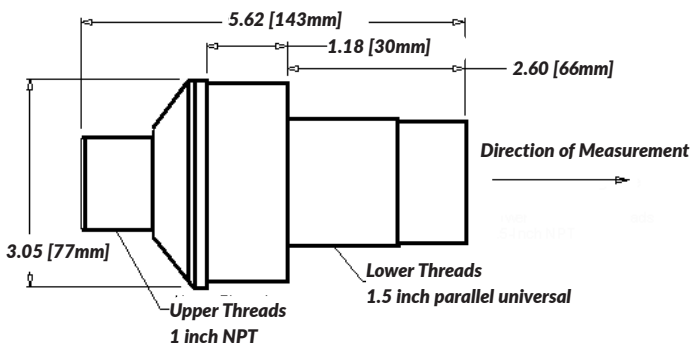

Mechanical

Mounting Threads:

Lower 1-1/2-in. Parallel

Upper 1-in. NPT
(1 in. BSP tapered, or M32 x 1.5 metric by special order)

Attached Cable:

PUR jacket, 6.5ft (2 m) long

Weight:

21.2 oz. (0.60 kg)