

Schrupp Hydraulic Accumulators



| TABLE OF CONTENTS | | |
|--|------------------------|----------|
| DESCRIPTION | SPECIFICATION NO. | PAGE NO. |
| Standard Bladder Accumulators, 3000 psi | ABA-001 | 4 |
| Standard Bladder Accumulators, 5000 psi | ABA-002 | 5 |
| Top Repairable Bladder Accumulators, 3000 psi | ABA-003 | 6 |
| Top Repairable Bladder Accumulators, 5000 psi | ABA-004 | 7 |
| Transfer Barrier Bladder Accumulators, 3000 psi | ABA-001---T | 8 |
| Bladder Accumulator Gas Bottles, 3000 psi | ABA-001---G | 9 |
| Bladder Accumulator Accessories | | 10 |
| Bladder Accumulator Mounting Brackets | | 11 |
| Replacement Bladders & Optional Fluid Ports | | 12 |
| Bladder Accumulators Ordering Information | | 13 |
| Bladder Accumulator Maintenance Instructions | | 14-16 |
| Bladder Accumulator, Top Repairable, Welded Construction | ADA-HTR | 17 |
| Diaphragm Accumulator Welded Construction | ADA-H | 18 |
| Diaphragm Accumulator Threaded Construction | ADA-HST | 19 |
| Diaphragm Accumulator, PVC or Polypropylene Body | ADA-HSTPVC ADA-HSTP | 20 |
| Diaphragm Accumulator, Stainless Steel Body | ADA-HSTX | 21 |
| Diaphragm Accumulator, Charging Assembly & Gas Valve | SCA-160 SCA-162 | 22 |
| Bladder Type Pulsation Dampeners | HBX | 23 |
| Bladder Type Pulsation Dampeners, Top Repairable | HTRX BXT | 24 |
| Accumulator Special Executions | | 25 |

HL Hydraulic, Inc.

BLADDER ACCUMULATORS



Specification No. ABA-001

ASME VIII Range 3000 psi

TECHNICAL

Maximum Working Pressure: 3000 psi @ 200°F
Minimum Test Pressure: 4500 psi
Nominal Capacities: 1 quart, 1.0, 2.5, 5.0, 10.0 & 15.0 gal.

DESIGN

Shell: Designed and Manufactured in accordance with ASME Code Rules, Section VIII, Division 1
 Material - Chrome Molybdenum Steel, SA372 Grade E, Class 70
 (Meets 4 : 1 Safety Requirements)

Separator Bag: Totally enclosed molded synthetic rubber bag in a range of materials. Integral steel stem fitted with gas valve assembly, sealing cap, O-ring, locknut and protective cap.

Fluid Port Assembly: Poppet type assembly manufactured in AISI 4130 carbon steel specifications, complete with molded retaining rings, locking ring and bleed plug.

Inspection: Shell certified throughout manufacture with witness testing by independent authorities, ASME approval and "U" code stamped.

Finish: One coat epoxy based primer.
 Special finishes available.

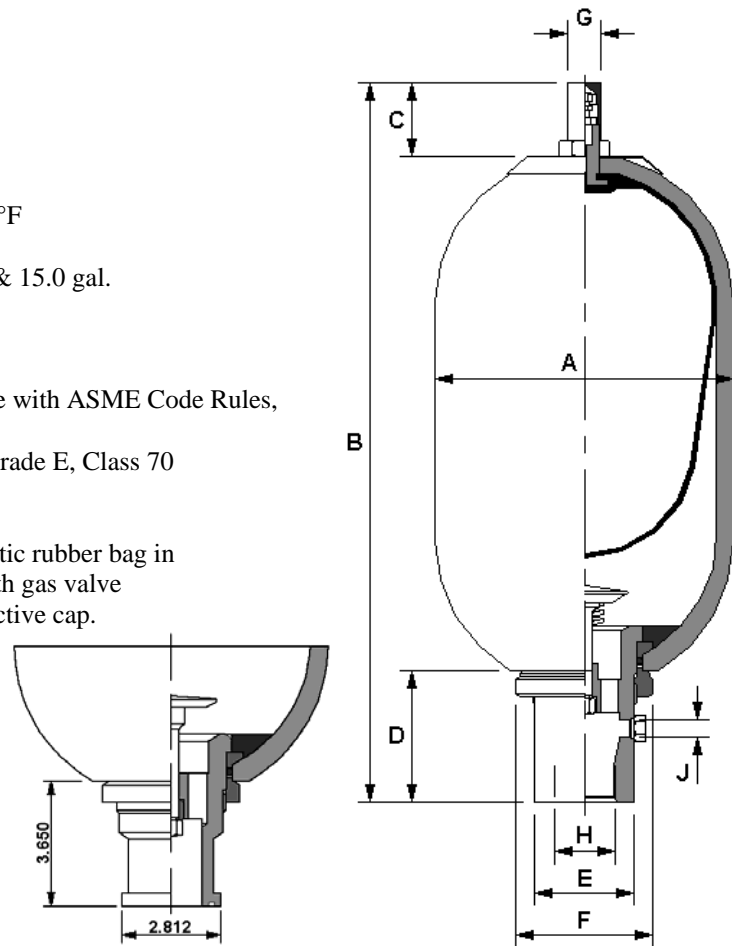

2.5 – 15 Gallon Split Flange
 Fluid Port Option

| Nominal Capacity Gallons (Liters) | Gas Volume Cu. in. (Liters) | Max. WP psi (bar) | Weight Lbs. (kg) | Dimensions, inch (mm) | | | | | | | Hydraulic Ports | |
|---|-----------------------------------|----------------------------|------------------------|-----------------------|-----------------|--------------|--------------|----------------|----------------|----------------|---------------------------------|----------------------|
| | | | | A | B | C | D | E | F | G | H Size ¹ (Thread) | J Size (Thread) |
| 1 Qt. (0.95) | 60 (0.95) | 3000 ² (207) | 10 (4.5) | 4.50 (114) | 11.25 (286) | 1.75 (45) | 2.00 (51) | 1.75 (45) | 2.50 (63.5) | 1.00 (25.4) | SAE #16 (1-5/16"-12) | N/A |
| 1.0 (3.79) | 231 (3.79) | 3000 (207) | 30 (13.3) | 6.75 (171) | 16.25 (413) | 2.25 (58) | 2.75 (70) | 2.36 (59.9) | 3.13 (79.5) | 1.00 (25.4) | SAE #20 (1-5/8"-12) | SAE #6 (9/16"-18) |
| 2.5 (9.46) | 600 (9.8) | 3000 (207) | 80 (36) | 9.00 (230) | 21.25 (540) | 2.25 (58) | 3.50 (89) | 3.00 (76.2) | 4.13 (105) | 1.00 (25.4) | SAE #24 (1-7/8"-12) | SAE #6 (9/16"-18) |
| 5.0 (18.9) | 1203 (19.7) | 3000 (207) | 120 (55) | 9.00 (230) | 33.50 (851) | 2.25 (58) | 3.50 (89) | 3.00 (76.2) | 4.13 (105) | 1.00 (25.4) | SAE #24 (1-7/8"-12) | SAE #6 (9/16"-18) |
| 10.0 (37.9) | 2259 (37.0) | 3000 (207) | 220 (100) | 9.00 (230) | 54.50 (1384) | 2.25 (58) | 3.50 (89) | 3.00 (76.2) | 4.13 (105) | 1.00 (25.4) | SAE #24 (1-7/8"-12) | SAE #6 (9/16"-18) |
| 15.0 (56.8) | 3440 (56.3) | 3000 (207) | 300 (133) | 9.00 (230) | 78.00 (1981) | 2.25 (58) | 3.50 (89) | 3.00 (76.2) | 4.13 (105) | 1.00 (25.4) | SAE #24 (1-7/8"-12) | SAE #6 (9/16"-18) |

All dimensions subject to change without notice

¹ Optional Fluid Ports Available.

² In accordance with ASME VIII calculations only.

BLADDER ACCUMULATORS



Specification No. ABA-002

ASME VIII Range 5000 psi

TECHNICAL

Maximum Working Pressure: 5000 psi @ 200°F
Minimum Test Pressure: 7500 psi
Nominal Capacities: 2.5, 5.0, 10.0 & 15.0 gal.

DESIGN

Shell: Designed and Manufactured in accordance with ASME Code Rules, Section VIII, Division 1
 Material - Chrome Molybdenum Steel, SA372 Grade E Class 70 (Meets 4 : 1 Safety Requirements)

Separator Bag: Totally enclosed molded synthetic rubber bag in a range of materials. Integral steel stem fitted with gas valve assembly, sealing cap, O-ring, locknut and protective cap.

Fluid Port Assembly: Poppet type assembly manufactured in AISI 4130 carbon steel specifications, complete with molded retaining rings, locking ring and bleed plug.

Inspection: Shell certified throughout manufacture with witness testing by independent authorities, ASME approval and “U” code stamped.

Finish: One coat epoxy based primer. Special finishes available.

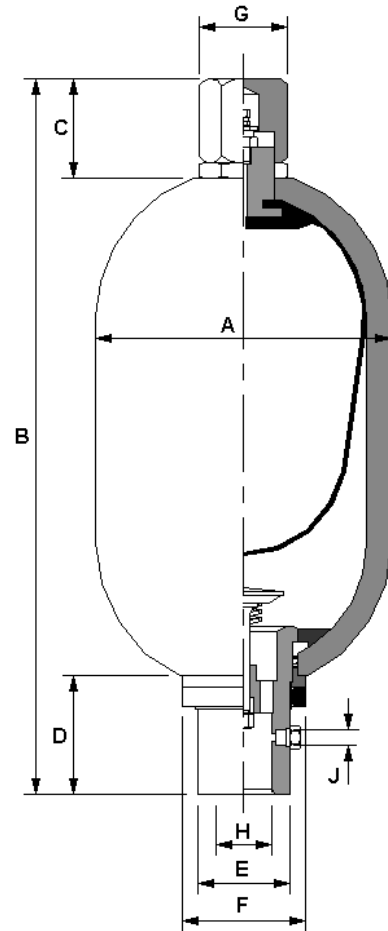

| Nominal Capacity Gallons (Liters) | Gas Volume Cu. in. (Liters) | Max. WP psi (bar) | Weight Lbs. (kg) | Dimensions, inch (mm) | | | | | | | Hydraulic Ports | |
|---|-----------------------------------|-------------------------|------------------------|-----------------------|-----------------|--------------|---------------|----------------|---------------|----------------|---------------------------------|----------------------|
| | | | | A | B | C | D | E | F | G Hex. | H Size ¹ (Thread) | J Size (Thread) |
| 2.5 (9.46) | 600 (9.8) | 5000 (345) | 125 (57) | 9.75 (248) | 24.00 (610) | 3.25 (83) | 4.00 (102) | 3.00 (76.2) | 4.00 (102) | 2.50 (63.5) | SAE #24 (1-7/8"-12) | SAE #6 (9/16"-18) |
| 5.0 (18.9) | 1203 (19.7) | 5000 (345) | 200 (91) | 9.75 (248) | 36.00 (914) | 3.25 (83) | 4.00 (102) | 3.00 (76.2) | 4.00 (102) | 2.50 (63.5) | SAE #24 (1-7/8"-12) | SAE #6 (9/16"-18) |
| 10.0 (37.9) | 2259 (37.0) | 5000 (345) | 350 (159) | 9.75 (248) | 57.00 (1448) | 3.25 (83) | 4.00 (102) | 3.00 (76.2) | 4.00 (102) | 2.50 (63.5) | SAE #24 (1-7/8"-12) | SAE #6 (9/16"-18) |
| 15.0 (56.8) | 3440 (56.3) | 5000 (345) | 500 (227) | 9.75 (248) | 80.00 (2032) | 3.25 (83) | 4.00 (102) | 3.00 (76.2) | 4.00 (102) | 2.50 (63.5) | SAE #24 (1-7/8"-12) | SAE #6 (9/16"-18) |

All dimensions subject to change without notice

¹ Optional Fluid Ports Available.

HL Hydraulic, Inc.

P.O. Box 450 • Seneca, PA 16346 • Phone 814-677-4086 • Toll Free 877-677-4086 • Fax 814-677-4087
 Website: www.hlhydraulic.com • E-mail: sales@hlhydraulic.com

BLADDER ACCUMULATORS



Specification No. ABA-003

ASME VIII Range (Top Repairable) 3000 psi

TECHNICAL

Maximum Working Pressure: 3000 psi @ 200°F

Minimum Test Pressure: 4500 psi

Nominal Capacities: 2.5, 5.0, 10.0 & 15.0 gal.

DESIGN

Shell: Designed and Manufactured in accordance with ASME Code Rules, Section VIII, Division 1

Material - Chrome Molybdenum Steel, SA372 Grade E Class 70
(Meets 4 : 1 Safety Requirements)

Separator Bag: Totally enclosed molded synthetic rubber bag in a range of materials. Integral steel stem fitted with gas valve assembly, sealing cap, O-ring, locknut and protective cap.

Fluid Port Assembly: Poppet type assembly manufactured in AISI 4130 carbon steel specifications, complete with molded retaining rings, locking ring and bleed plug.

Inspection: Shell certified throughout manufacture with witness testing by independent authorities, ASME approval and “U” code stamped.

Finish: One coat epoxy based primer. Special finishes available.

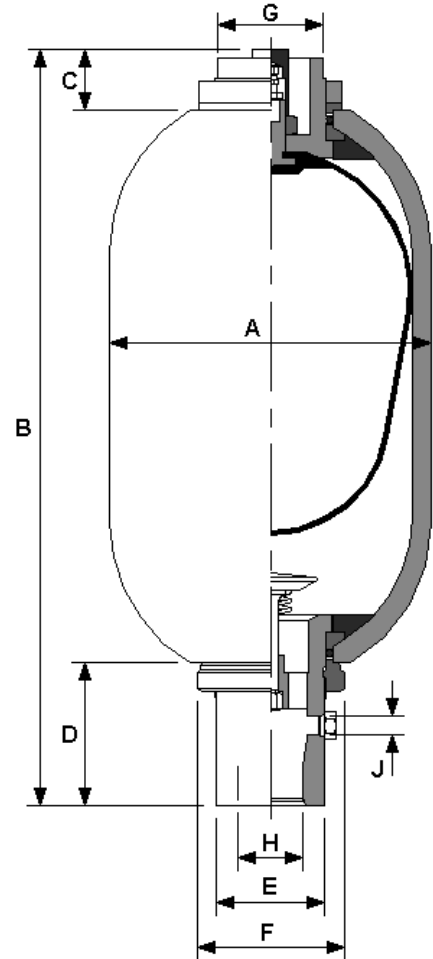

| Nominal Capacity Gallons (Liters) | Gas Volume Cu. in. (Liters) | Max. WP psi (bar) | Weight Lbs. (kg) | Dimensions, inch (mm) | | | | | | | Hydraulic Ports | |
|---|-----------------------------------|-------------------------|------------------------|-----------------------|-----------------|--------------|--------------|----------------|---------------|----------------|---------------------------------|----------------------|
| | | | | A | B | C | D | E | F | G | H Size ¹ (Thread) | J Size (Thread) |
| 2.5 (9.46) | 600 (9.8) | 3000 (207) | 80 (36) | 9.00 (230) | 21.25 (540) | 1.75 (45) | 3.50 (89) | 3.00 (76.2) | 4.13 (105) | 3.00 (76.2) | SAE #24 (1-7/8"-12) | SAE #6 (9/16"-18) |
| 5.0 (18.9) | 1203 (19.7) | 3000 (207) | 120 (55) | 9.00 (230) | 33.50 (851) | 1.75 (45) | 3.50 (89) | 3.00 (76.2) | 4.13 (105) | 3.00 (76.2) | SAE #24 (1-7/8"-12) | SAE #6 (9/16"-18) |
| 10.0 (37.9) | 2259 (37.0) | 3000 (207) | 220 (100) | 9.00 (230) | 54.50 (1384) | 1.75 (45) | 3.50 (89) | 3.00 (76.2) | 4.13 (105) | 3.00 (76.2) | SAE #24 (1-7/8"-12) | SAE #6 (9/16"-18) |
| 15.0 (56.8) | 3440 (56.3) | 3000 (207) | 300 (133) | 9.00 (230) | 78.00 (1981) | 1.75 (45) | 3.50 (89) | 3.00 (76.2) | 4.13 (105) | 3.00 (76.2) | SAE #24 (1-7/8"-12) | SAE #6 (9/16"-18) |

All dimensions subject to change without notice

¹ Optional Fluid Ports Available.

BLADDER ACCUMULATORS



Specification No. ABA-004

ASME VIII Range (Top Repairable) 5000 psi

TECHNICAL

Maximum Working Pressure: 5000 psi @ 200°F

Minimum Test Pressure: 7500 psi

Nominal Capacities: 2.5, 5.0, 10.0 & 15.0 gal.

DESIGN

Shell: Designed and Manufactured in accordance with ASME Code Rules, Section VIII, Division 1

Material - Chrome Molybdenum Steel, SA372 Grade E Class 70
(Meets 4 : 1 Safety Requirements)

Separator Bag: Totally enclosed molded synthetic rubber bag in a range of materials. Integral steel stem fitted with gas valve assembly, sealing cap, O-ring, locknut and protective cap.

Fluid Port Assembly: Poppet type assembly manufactured in AISI 4130 carbon steel specifications, complete with molded retaining rings, locking ring and bleed plug.

Inspection: Shell certified throughout manufacture with witness testing by independent authorities, ASME approval and “U” code stamped.

Finish: One coat epoxy based primer. Special finishes available.

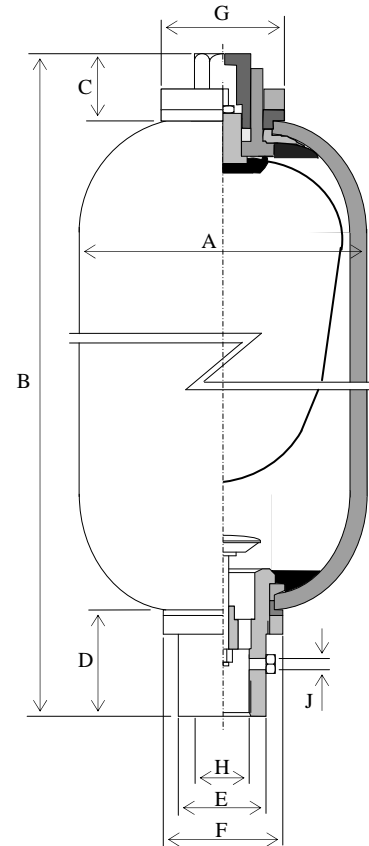

| Nominal Capacity Gallons (Liters) | Gas Volume Cu. in. (Liters) | Max. WP psi (bar) | Weight Lbs. (kg) | Dimensions, inch (mm) | | | | | | | Hydraulic Ports | |
|---|-----------------------------------|-------------------------|------------------------|-----------------------|-----------------|--------------|---------------|----------------|---------------|----------------|---------------------------------|----------------------|
| | | | | A | B | C | D | E | F | G Hex. | H Size ¹ (Thread) | J Size (Thread) |
| 2.5 (9.46) | 600 (9.8) | 5000 (345) | 125 (57) | 9.75 (248) | 24.00 (610) | 3.25 (83) | 4.00 (102) | 3.00 (76.2) | 4.00 (102) | 2.50 (63.5) | SAE #24 (1-7/8"-12) | SAE #6 (9/16"-18) |
| 5.0 (18.9) | 1203 (19.7) | 5000 (345) | 200 (91) | 9.75 (248) | 36.00 (914) | 3.25 (83) | 4.00 (102) | 3.00 (76.2) | 4.00 (102) | 2.50 (63.5) | SAE #24 (1-7/8"-12) | SAE #6 (9/16"-18) |
| 10.0 (37.9) | 2259 (37.0) | 5000 (345) | 350 (159) | 9.75 (248) | 57.00 (1448) | 3.25 (83) | 4.00 (102) | 3.00 (76.2) | 4.00 (102) | 2.50 (63.5) | SAE #24 (1-7/8"-12) | SAE #6 (9/16"-18) |
| 15.0 (56.8) | 3440 (56.3) | 5000 (345) | 500 (227) | 9.75 (248) | 80.00 (2032) | 3.25 (83) | 4.00 (102) | 3.00 (76.2) | 4.00 (102) | 2.50 (63.5) | SAE #24 (1-7/8"-12) | SAE #6 (9/16"-18) |

All dimensions subject to change without notice

¹ Optional Fluid Ports Available.

HL Hydraulic, Inc.

P.O. Box 450 • Seneca, PA 16346 • Phone 814-677-4086 • Toll Free 877-677-4086 • Fax 814-677-4087
Website: www.hlhydraulic.com • E-mail: sales@hlhydraulic.com

BLADDER ACCUMULATORS



Specification No. ABA-001- - -T

Transfer Barriers

ASME VIII Range 3000 psi

TECHNICAL

Maximum Working Pressure: 3000 psi @ 200°F
Minimum Test Pressure: 4500 psi
Nominal Capacities: 2.5, 5.0, 10.0 & 15.0 gal.

DESIGN

Shell: Designed and Manufactured in accordance with ASME Code Rules, Section VIII, Division 1
 Material - Chrome Molybdenum Steel, SA372 Grade E, Class 70
 (Meets 4 : 1 Safety Requirements)

Separator Bag: Totally enclosed molded synthetic rubber bag in a range of materials. Integral steel stem fitted with gas tube, O-ring seals, locknut and gas tube adapter nut.

Fluid Port Assembly: Poppet type assembly manufactured in AISI 4130 carbon steel specifications, complete with molded retaining rings, locking ring and bleed plug.

Inspection: Shell certified throughout manufacture with witness testing by independent authorities, ASME approval and “U” code stamped.

Finish: One coat epoxy based primer. Special finishes available.

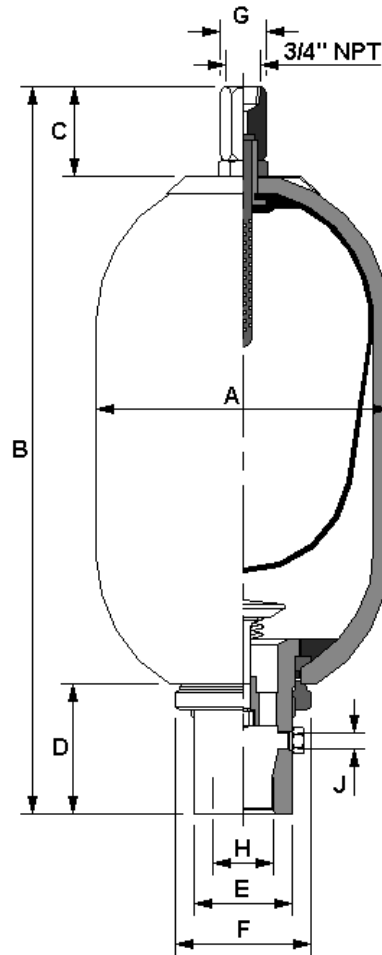

| Nominal Capacity Gallons (Liters) | Gas Volume Cu. in. (Liters) | Max. WP psi (bar) | Weight Lbs. (kg) | Dimensions, inch (mm) | | | | | | | | Hydraulic Ports | |
|---|-----------------------------------|-------------------------|------------------------|-----------------------|-----------------|--------------|--------------|----------------|---------------|----------------|------------------------|----------------------|--|
| | | | | A | B | C | D | E | F | G Hex. | H Size' (Thread) | J Size (Thread) | |
| 2.5 (9.46) | 600 (9.8) | 3000 (207) | 80 (36) | 9.00 (230) | 21.75 (553) | 2.75 (70) | 3.50 (89) | 3.00 (76.2) | 4.13 (105) | 1.25 (31.8) | SAE #24 (1-7/8"-12) | SAE #6 (9/16"-18) | |
| 5.0 (18.9) | 1203 (19.7) | 3000 (207) | 120 (55) | 9.00 (230) | 34.00 (864) | 2.75 (70) | 3.50 (89) | 3.00 (76.2) | 4.13 (105) | 1.25 (31.8) | SAE #24 (1-7/8"-12) | SAE #6 (9/16"-18) | |
| 10.0 (37.9) | 2259 (37.0) | 3000 (207) | 220 (100) | 9.00 (230) | 55.00 (1397) | 2.75 (70) | 3.50 (89) | 3.00 (76.2) | 4.13 (105) | 1.25 (31.8) | SAE #24 (1-7/8"-12) | SAE #6 (9/16"-18) | |
| 15.0 (56.8) | 3440 (56.3) | 3000 (207) | 300 (133) | 9.00 (230) | 78.50 (1994) | 2.75 (70) | 3.50 (89) | 3.00 (76.2) | 4.13 (105) | 1.25 (31.8) | SAE #24 (1-7/8"-12) | SAE #6 (9/16"-18) | |

All dimensions subject to change without notice

¹ Optional Fluid Ports Available.

BLADDER ACCUMULATORS



Specification No. ABA-001- - - G

Gas Bottles

ASME VIII Range 3000 psi

TECHNICAL

Maximum Working Pressure: 3000 psi @ 200°F
Minimum Test Pressure: 4500 psi
Nominal Capacities: 2.5, 5.0, 10.0 & 15.0 gal.

DESIGN

Shell: Designed and Manufactured in accordance with ASME Code Rules, Section VIII, Division 1
 Material - Chrome Molybdenum Steel, SA372 Grade E, Class 70 (Meets 4 : 1 Safety Requirements)

Fluid Port Assembly: Assembly manufactured in AISI 4130 carbon steel specifications, complete with molded retaining rings, locking ring and bleed plug.

Drain Port Assembly: Molded Buna-N sealing adapter. Integral steel stem fitted with locknut and drain plug.

Inspection: Shell certified throughout manufacture with witness testing by independent authorities, ASME approval and "U" code stamped.

Finish: One coat epoxy based primer. Special finishes available.

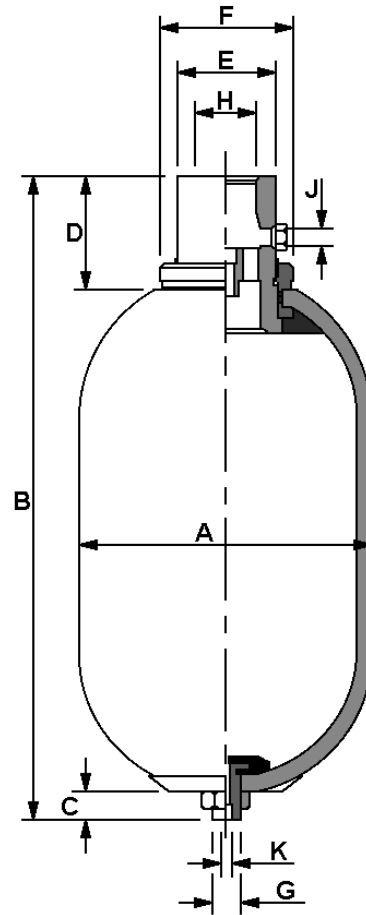

| Nominal Capacity Gallons (Liters) | Gas Volume Cu. in. (Liters) | Max. WP psi (bar) | Weight Lbs. (kg) | Dimensions, inch (mm) | | | | | | | Ports | | |
|---|-----------------------------------|-------------------------|------------------------|-----------------------|-----------------|--------------|--------------|----------------|---------------|--------------|---------------------------------|----------------------|---------------------|
| | | | | A | B | C | D | E | F | G | H Size ¹ (Thread) | J Size (Thread) | K Size (Thread) |
| 2.5 (9.46) | 600 (9.8) | 3000 (207) | 80 (36) | 9.00 (230) | 20.38 (518) | 0.88 (22) | 3.50 (89) | 3.00 (76.2) | 4.13 (105) | 0.88 (22) | SAE #24 (1-7/8"-12) | SAE #6 (9/16"-18) | SAE #3 (3/8"-24) |
| 5.0 (18.9) | 1203 (19.7) | 3000 (207) | 120 (55) | 9.00 (230) | 32.63 (829) | 0.88 (22) | 3.50 (89) | 3.00 (76.2) | 4.13 (105) | 0.88 (22) | SAE #24 (1-7/8"-12) | SAE #6 (9/16"-18) | SAE #3 (3/8"-24) |
| 10.0 (37.9) | 2259 (37.0) | 3000 (207) | 220 (100) | 9.00 (230) | 53.63 (1362) | 0.88 (22) | 3.50 (89) | 3.00 (76.2) | 4.13 (105) | 0.88 (22) | SAE #24 (1-7/8"-12) | SAE #6 (9/16"-18) | SAE #3 (3/8"-24) |
| 15.0 (56.8) | 3440 (56.3) | 3000 (207) | 300 (133) | 9.00 (230) | 77.13 (1959) | 0.88 (22) | 3.50 (89) | 3.00 (76.2) | 4.13 (105) | 0.88 (22) | SAE #24 (1-7/8"-12) | SAE #6 (9/16"-18) | SAE #3 (3/8"-24) |

All dimensions subject to change without notice

¹ Optional Fluid Ports Available.

HL Hydraulic, Inc.

P.O. Box 450 • Seneca, PA 16346 • Phone 814-677-4086 • Toll Free 877-677-4086 • Fax 814-677-4087
 Website: www.hlhydraulic.com • E-mail: sales@hlhydraulic.com

BLADDER ACCUMULATORS



Accessories

Available from Schrupp



SCA-313
Charging & Gauging
Head Assembly



SCA-31 3,000 psi Pressure Gauge
SCA-49 2,000 psi Pressure Gauge
SCA-51 5,000 psi Pressure Gauge



SCA-53 1-15 Gallon Valve Stem
SCA-52 5,000 psi Gas Valve
SCA-47 Valve Stem Extension



SCA-314 Head Assembly



SCA-44 Hose Assembly



SBP Bag Puller Rod
SCH-CT Valve Core Cross Type Tool
SCH-SW Spanner Wrench



SCA-3 Complete 3,000 psi Charging Assembly

BLADDER ACCUMULATORS



Mounting Brackets for Accumulators

Designed for specific use on Accumulator installation, both Clamps & Bases are supplied complete with Rubber Support to ensure rigid mounting.

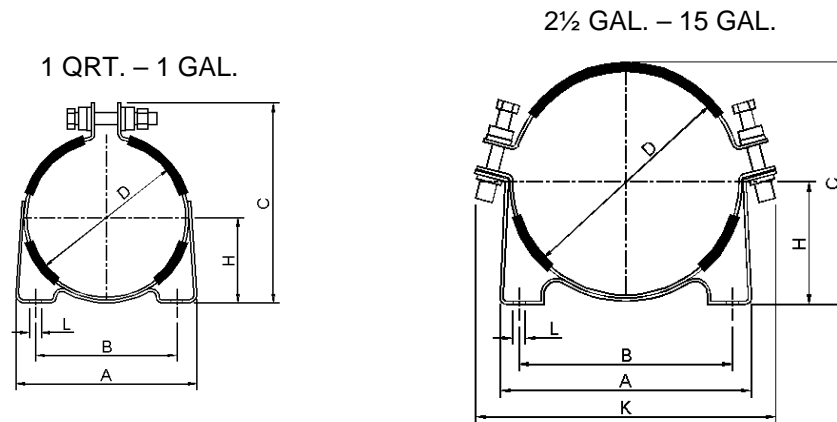

ACCUMULATOR BRACKETS

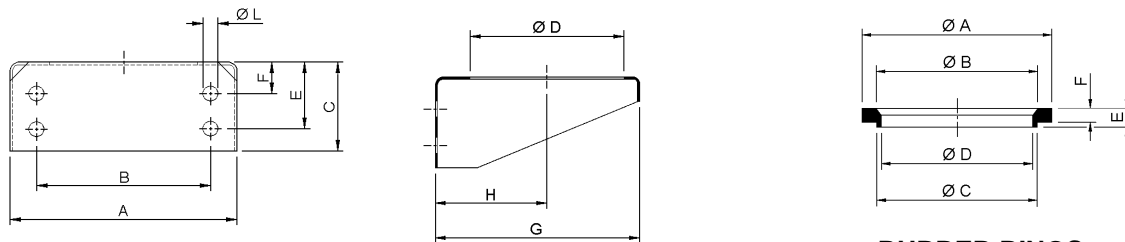

BASE BRACKETS

RUBBER RINGS

| ACCUMULATOR BRACKETS | | | | | | | | | |
|---------------------------------|---------------|---------------|---------------|----------------------|---------------|---------------|---------------------------|-------------------|----------------------|
| MODEL | A In. (mm) | B In. (mm) | C In. (mm) | D (DIA.) In. (mm) | H In. (mm) | K In. (mm) | L (Slot) In. (mm) | WIDTH In. (mm) | |
| SCH-1 QRT | 5.26 (134) | 3.94 (100) | 6.68 (170) | 4.51 (115) | 2.87 (73) | --- | 0.35 x 0.50 (8.9 x 12.7) | 1.25 (32) | |
| SCH-1 GAL | 7.50 (191) | 6.02 (153) | 9.00 (229) | 6.75 (171) | 3.94 (100) | --- | 0.35 x 0.50 (8.9 x 12.7) | 1.25 (32) | |
| SCH-2.5-15 GAL | 10.0 (254) | 8.50 (216) | 9.67 (246) | 8.90 (226) | 4.84 (123) | 12.5 (317) | 0.59 (15) | 1.58 (40) | |
| BASE BRACKETS WITH RUBBER RINGS | | | | | | | | | |
| MODEL | A In. (mm) | B In. (mm) | C In. (mm) | D (DIA.) In. (mm) | E In. (mm) | F In. (mm) | G In. (mm) | H In. (mm) | L (DIA.) In. (mm) |
| SB-1 GAL | 10.2 (260) | 7.87 (200) | 3.94 (100) | 4.72 (120) | 2.95 (75) | 1.38 (35) | 8.86 (225) | 3.94 (100) | 0.67 (17) |
| SB-2.5-15 GAL | 10.2 (260) | 7.87 (200) | 3.94 (100) | 6.69 (170) | 2.95 (75) | 1.38 (35) | 8.86 (225) | 4.84 (123) | 0.67 (17) |
| RUBBER RINGS | | | | | | | | | |
| MODEL | A In. (mm) | B In. (mm) | C In. (mm) | D (DIA.) In. (mm) | E In. (mm) | F In. (mm) | USE WITH BASE BRACKET NO. | | |
| SCA-138 | 5.91 (150) | 4.72 (120) | 4.69 (119) | 4.25 (108) | 0.79 (20) | 0.59 (15) | SB-1 GAL | | |
| SCA-139 | 7.87 (200) | 6.69 (170) | 6.65 (169) | 6.26 (159) | 0.79 (20) | 0.59 (15) | SB-2.5 GAL - 15 GAL | | |

All dimensions subject to change without notice

HL Hydraulic, Inc.

P.O. Box 450 • Seneca, PA 16346 • Phone 814-677-4086 • Toll Free 877-677-4086 • Fax 814-677-4087 Website: www.hlhydraulic.com • E-mail: sales@hlhydraulic.com

BLADDER ACCUMULATORS



Replacement Bladders

3000 PSI BLADDER KITS

| Size | Bladder Material & Part No. | | | | |
|-----------|-----------------------------|--------------------|--------------------|--------------------|--------------------|
| | Buna-N | Butyl | EPR | Viton | Low Temp. |
| 1 Quart | ABA-001-B-.25gal-N | ABA-001-B-.25gal-B | ABA-001-B-.25gal-E | ABA-001-B-.25gal-V | ABA-001-B-.25gal-L |
| 1 Gallon | ABA-001-B-1gal-N | ABA-001-B-1gal-B | ABA-001-B-1gal-E | ABA-001-B-1gal-V | ABA-001-B-1gal-L |
| 2½ Gallon | ABA-001-B-2.5gal-N | ABA-001-B-2.5gal-B | ABA-001-B-2.5gal-E | ABA-001-B-2.5gal-V | ABA-001-B-2.5gal-L |
| 5 Gallon | ABA-001-B-5gal-N | ABA-001-B-5gal-B | ABA-001-B-5gal-E | ABA-001-B-5gal-V | ABA-001-B-5gal-L |
| 10 Gallon | ABA-001-B-10gal-N | ABA-001-B-10gal-B | ABA-001-B-10gal-E | ABA-001-B-10gal-V | ABA-001-B-10gal-L |
| 15 Gallon | ABA-001-B-15gal-N | ABA-001-B-15gal-B | ABA-001-B-15gal-E | ABA-001-B-15gal-V | ABA-001-B-15gal-L |

5000 PSI BLADDER KITS

| Size | Bladder Material & Part No. | | | | |
|-----------|-----------------------------|--------------------|--------------------|--------------------|--------------------|
| | Buna-N | Butyl | EPR | Viton | Low Temp. |
| 2½ Gallon | ABA-002-B-2.5gal-N | ABA-002-B-2.5gal-B | ABA-002-B-2.5gal-E | ABA-002-B-2.5gal-V | ABA-002-B-2.5gal-L |
| 5 Gallon | ABA-002-B-5gal-N | ABA-002-B-5gal-B | ABA-002-B-5gal-E | ABA-002-B-5gal-V | ABA-002-B-5gal-L |
| 10 Gallon | ABA-002-B-10gal-N | ABA-002-B-10gal-B | ABA-002-B-10gal-E | ABA-002-B-10gal-V | ABA-002-B-10gal-L |
| 15 Gallon | ABA-002-B-15gal-N | ABA-002-B-15gal-B | ABA-002-B-15gal-E | ABA-002-B-15gal-V | ABA-002-B-15gal-L |

3000 PSI TOP REPAIRABLE BLADDER KITS

| Size | Bladder Material & Part No. | | | | |
|-----------|-----------------------------|--------------------|--------------------|--------------------|--------------------|
| | Buna-N | Butyl | EPR | Viton | Low Temp. |
| 2½ Gallon | ABA-003-B-2.5gal-N | ABA-003-B-2.5gal-B | ABA-003-B-2.5gal-E | ABA-003-B-2.5gal-V | ABA-003-B-2.5gal-L |
| 5 Gallon | ABA-003-B-5gal-N | ABA-003-B-5gal-B | ABA-003-B-5gal-E | ABA-003-B-5gal-V | ABA-003-B-5gal-L |
| 10 Gallon | ABA-003-B-10gal-N | ABA-003-B-10gal-B | ABA-003-B-10gal-E | ABA-003-B-10gal-V | ABA-003-B-10gal-L |
| 15 Gallon | ABA-003-B-15gal-N | ABA-003-B-15gal-B | ABA-003-B-15gal-E | ABA-003-B-15gal-V | ABA-003-B-15gal-L |

5000 PSI TOP REPAIRABLE BLADDER KITS

| Size | Bladder Material & Part No. | | | | |
|-----------|-----------------------------|--------------------|--------------------|--------------------|--------------------|
| | Buna-N | Butyl | EPR | Viton | Low Temp. |
| 2½ Gallon | ABA-004-B-2.5gal-N | ABA-004-B-2.5gal-B | ABA-004-B-2.5gal-E | ABA-004-B-2.5gal-V | ABA-004-B-2.5gal-L |
| 5 Gallon | ABA-004-B-5gal-N | ABA-004-B-5gal-B | ABA-004-B-5gal-E | ABA-004-B-5gal-V | ABA-004-B-5gal-L |
| 10 Gallon | ABA-004-B-10gal-N | ABA-004-B-10gal-B | ABA-004-B-10gal-E | ABA-004-B-10gal-V | ABA-004-B-10gal-L |
| 15 Gallon | ABA-004-B-15gal-N | ABA-004-B-15gal-B | ABA-004-B-15gal-E | ABA-004-B-15gal-V | ABA-004-B-15gal-L |

FLUID PORTS

| Fluid Port Specifications (Internal Threads) | 1 Quart, 3000 psi Bladder Accumulator | | 1 Gallon, 3000 psi Bladder Accumulator | | 2½-15 Gallon, 3000 psi Bladder Accumulator | | 2½-15 Gallon, 5000 psi Bladder Accumulator | |
|---|---------------------------------------|----------------|--|---------------|--|---------------|--|---------------|
| | N | 1" NPT | N | 1¼" NPT | N | 2" NPT | N | 2" NPT |
| | S | 1-5/16"-12 SAE | S | 1-5/8"-12 SAE | S | 1-7/8"-12 SAE | S | 1-7/8"-12 SAE |
| | | | | F | 2" Code 61 | F | 1½" Code 62 | |

CHARGING GAS VALVE

- SCA-53 - 3000 PSI
- SCA-52 - 5000 PSI

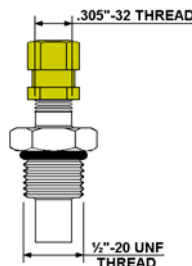

BLADDER ACCUMULATORS



Ordering Information

MODEL CODE **ABA**

TYPE

001 - 3,000 psi Bottom Repairable
 002 - 5,000 psi Bottom Repairable
 003 - 3,000 psi Top Repairable
 004 - 5,000 psi Top Repairable

FLUID PORT

S - SAE Threaded
 N - NPT Threaded
 F - Split Flanged

NOMINAL SIZE

| | |
|---------------------|-------------------|
| .25GAL - 1 quart | 5GAL - 5 gallon |
| 1GAL - 1 gallon | 10GAL - 10 gallon |
| 2.5GAL - 2.5 gallon | 15GAL - 15 gallon |

BLADDER MATERIAL

| | |
|-----------------------------|-----------|
| N - Buna-N | B - Butyl |
| V - Viton | E - EPR |
| LT - Low Temperature Buna-N | |

AVAILABLE OPTIONS

G - Gas Bottle
 T - Transfer Barrier
 W - Water Service (Nickel Plated)
 22 - Appendix 22 Approval

Not all combinations are available. See specification sheets for availability.

Accumulator Charging Assemblies

MODEL CODE SCA -

PRESSURE RANGE

3 - 3,000 psi
 5 - 5,000 psi
 48 - 3,000 psi w/ 2,000 psi Gauge

See accessories page for other available accumulator accessories.

HL Hydraulic, Inc.

P.O. Box 450 • Seneca, PA 16346 • Phone 814-677-4086 • Toll Free 877-677-4086 • Fax 814-677-4087 Website: www.hlhydraulic.com • E-mail: sales@hlhydraulic.com

BLADDER ACCUMULATORS



Maintenance Instructions

Tools needed to repair Schrupp Bladder Accumulators.

| Part Number | Description |
|----------------|-----------------------------|
| SCH-CT | Valve Core Tool |
| SBP-1QT-2.5GAL | Bag Puller Rod (1qt-2.5gal) |
| SBP-5GAL | Bag Puller Rod (5gal) |
| SBP-10GAL | Bag Puller Rod (10gal) |
| SBP-15GAL | Bag Puller Rod (15gal) |
| SCH-SW | Spanner Wrench |

DISASSEMBLING THE ACCUMULATOR

1. Turn off system.
2. Release all hydraulic pressure from the system by opening the safety valve block or the control valve.
3. Remove the accumulator from the system.
4. Remove protective cap and valve cap from accumulator.
5. Using the valve core tool release the gas precharge pressure from the bladder.
6. Securely clamp the accumulator in a vise (preferably a chain vise). Make sure strips of padding or metal on the vise protect the shell.
7. Remove core from gas valve using valve core tool.
8. Remove bleeder plug from the fluid port and poppet assembly (if applicable).
9. Remove locknut from the fluid port and poppet assembly using a spanner wrench and an adjustable wrench.
10. Remove metal spacer (if applicable).
11. Push fluid port and poppet assembly into the shell.
12. Remove back-up ring, o-ring, o-ring washer, and anti-extrusion from the fluid port. Fold the anti-extrusion ring to remove from the shell.
13. Remove fluid port and poppet assembly from the shell.
14. Remove the bladder nut from the valve stem. Hold the valve stem with a wrench to prevent the bladder from twisting.
15. Depress the bladder and eliminate as much gas pressure as possible.
16. Remove the old bladder out of the bottom of the accumulator.

BLADDER ACCUMULATORS



Maintenance Instructions

REASSEMBLING THE ACCUMULATOR

1. Remove the valve core from the new bladder to release all of the air. Replace valve core.
2. Pour clean hydraulic oil into the shell to act as a lubricant.
3. Put the bladder puller rod into the shell through the valve stem opening, so that the end of the rod comes out through the fluid port opening.
4. Attach the bladder puller rod to the valve stem of the new bladder.
5. Carefully pull the bladder through the fluid port opening and the valve stem through the valve stem opening.
6. Detach the bladder puller rod and replace the nameplate and bladder nut.
7. Push the fluid port and poppet assembly into the shell.
8. Replace the anti-extrusion ring inside the shell.
9. Lubricate and Replace metal o-ring washer, o-ring, and back-up ring.
10. Pull the fluid port through the opening in the accumulator until it seats firmly.
11. Replace the metal space (if applicable) and the lock nut and hand tighten.
12. Using **DRY NITROGEN ONLY**, slowly pressurize the bladder with enough pressure (approximately 5 psig) to hold the fluid port and poppet assembly in place.
13. While holding the fluid port with an adjustable wrench, to prevent spinning, securely tighten the lock nut with the spanner wrench.
14. Replace the bleeder into the fluid port and poppet assembly (if applicable).

PRECHARGING

1. Remove protective cap and gas valve cap.
2. Install charging assembly on to the valve stem.
3. Fill the accumulator with system fluid through fluid port to provide cushion.
4. Using **DRY NITROGEN ONLY!!** Slowly precharge accumulator to 50 psi.
5. Continue to precharge to required pressure.
6. Remove the charging assembly, check for gas leakage at valve stem.
7. Replace gas valve cap and protective cap.

NOTE: It is recommended that the precharge pressure be checked at regular intervals to ensure optimal performance of the accumulator. A drop in precharge could cause damage to the bladder.

Recommended Precharge Pressure (P_0)

| | |
|------------------------|--|
| Auxiliary Power Source | $P_0 = 0.9 \times P_1$ |
| Shock Absorption | $P_0 = (0.6 \text{ to } 0.9) \times P_1$ |
| Pulsation Dampening | $P_0 = (0.6 \text{ to } 0.8) \times P_1$ |

P_1 = Minimum Working Pressure

HL Hydraulic, Inc.

P.O. Box 450 • Seneca, PA 16346 • Phone 814-677-4086 • Toll Free 877-677-4086 • Fax 814-677-4087 Website: www.hlhydraulic.com • E-mail: sales@hlhydraulic.com

BLADDER ACCUMULATORS



Maintenance Instructions

| ACCUMULATOR ASSEMBLY | |
|----------------------|---------------------|
| ITEM | DESCRIPTION |
| 1 | SHELL |
| 2 | BLADDER |
| 3 | NAME PLATE |
| 4 | GAS VALVE |
| 5 | BLADDER NUT |
| 6 | PROTECTIVE CAP |
| 7 | FLUID PORT ASSEMBLY |
| 8 | ANTI-EXTRUSION RING |
| 9 | METAL O-RING WASHER |
| 10 | O-RING |
| 11 | BACK-UP RING |
| 12 | METAL SPACER |
| 13 | LOCK NUT |
| 14 | BLEEDER PLUG |
| 15 | BLEEDER PLUG O-RING |

Note: Item 12, Metal Spacer, is no longer required in all applications.

| BLADDER KIT | |
|-------------|---------------------|
| ITEM | DESCRIPTION |
| 2 | BLADDER |
| 4 | GAS VALVE |
| 9 | METAL O-RING WASHER |
| 10 | O-RING |
| 11 | BACK-UP RING |

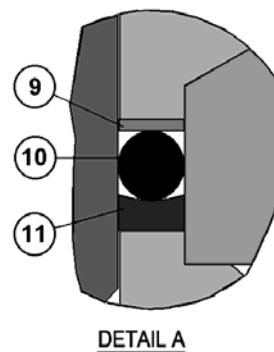
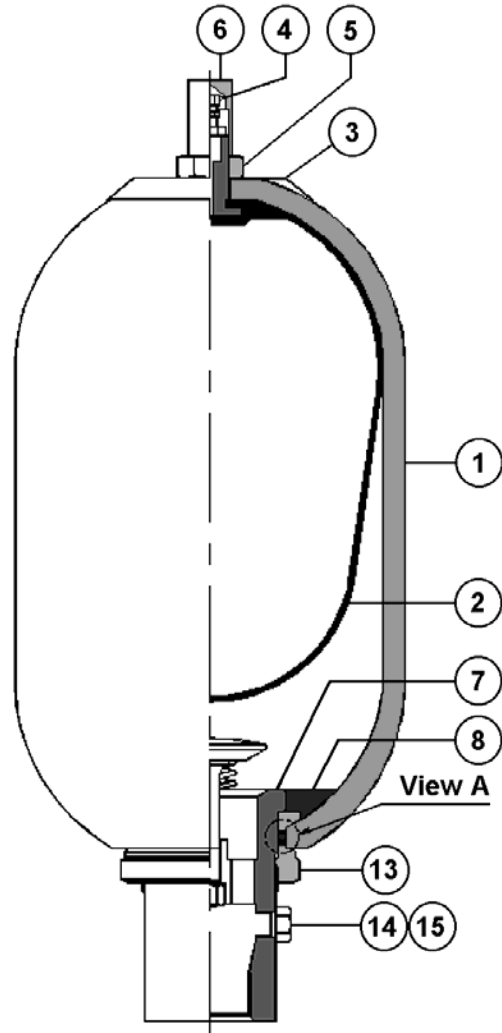

BLADDER ACCUMULATORS



Specification No. ADA-HTR

Top Repairable

TECHNICAL

Maximum Working Pressure: 3045 psi
Test Pressure: 4567 psi
Nominal Capacities: 20, 40, 90 cu.in., 1, 2.5 Ga

DESIGN

Body: Carbon steel painted black. An optional body construction with Zinc Dichromate plating, internally and externally, is available by adding a T to the end of the part number.

Gas Valve: Standard: SCA-162, $P_{max} = 4350$ psi
 Optional: SCA-53, $P_{max} = 3000$ psi

Bladder: Buna-N (Alternatives Available).
 Bladder is suitable for use with mineral oil and non-aggressive fluids.

Installation: Mounted in any position.

Working Temperatures: 5°F ⇒ 194°F

Pressure Ratio: Recommended: $P_2:P_0 = 2.5:1$
 Maximum: $P_2:P_0 = 4:1$

Special Modifications: Diaphragms for working temperatures from -60°F ⇒ 180°F

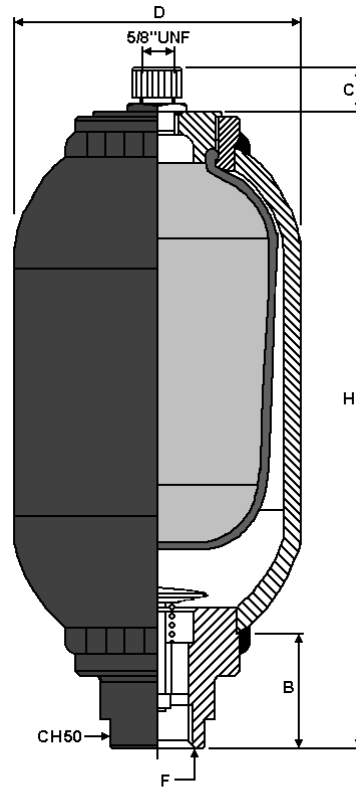

Fig. 2

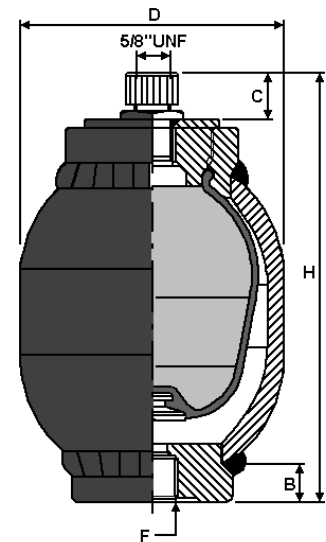

Fig. 1

| Part No. ADA-HTR | Gas Volume cu. in. (Liters) | Max. W.P. PSI (bar) | Weight lbs. (Kg.) | Max. Flow gpm (l/min) | Dimensions, inch (mm) | | | | Hydraulic Ports F Size (Thread) | Figure No. |
|---------------------|-----------------------------------|---------------------------|-------------------------|-----------------------------|-----------------------|---------------|--------------|--------------|---------------------------------------|------------|
| | | | | | H | D | C | B | | |
| 20CI | 21.4 (0.35) | 3045 (210) | 5.5 (2.5) | 11.9 (45) | 6.10 (155) | 3.62 (92) | 0.91 (23) | 0.79 (20) | M 18 x1.5 | 1 |
| 40CI | 42.7 (0.7) | 3045 (210) | 8.2 (3.7) | 10.6 (40) | 8.66 (220) | 3.62 (92) | 0.91 (23) | 0.79 (20) | M 18 x1.5 | 1 |
| 90CI | 91.5 (1.5) | 3045 (210) | 13.0 (5.9) | 10.6 (40) | 10.43 (265) | 4.53 (115) | 0.91 (23) | 0.98 (25) | M 18 x1.5 | 1 |
| 1GAL | 274.6 (4.5) | 3045 (210) | 30.9 (14) | 58.1 (220) | 14.37 (365) | 6.69 (170) | 0.91 (23) | 1.97 (50) | 3/4" BSP | 2 |
| 1GAL.1 | 274.6 (4.5) | 3045 (210) | 35.3 (16) | 105.6 (400) | 15.55 (395) | 6.69 (170) | 0.91 (23) | 3.15 (80) | 1-1/4" BSP | 2 |
| 2.5GAL | 610.2 (10) | 4350 (300) | 68.4 (31) | 79.3 (300) | 25.20 (640) | 6.69 (170) | 0.91 (23) | 3.15 (80) | 1-1/4" BSP | 2 |

All dimensions subject to change without notice.

HL Hydraulic, Inc.

P.O. Box 450 • Seneca, PA 16346 • Phone 814-677-4086 • Toll Free 877-677-4086 • Fax 814-677-4087
 Website: www.hlhydraulic.com • E-mail: sales@hlhydraulic.com

DIAPHRAGM ACCUMULATORS



Specification No. ADA-H

TECHNICAL

Maximum Working Pressure: 3045 psi
Test Pressure: 4567 psi
Nominal Capacities: 10, 20, 25, 40, 60, 85 cu.in.

DESIGN

Body: Cold formed steel with ends welded in protected argon atmosphere.

Diaphragm: Buna-N (Alternatives Available).
 Non replaceable diaphragm is suitable for use with mineral oils and non-aggressive fluids.

Installation: Mounted in any position.

Working Temperatures: 5°F ⇒ 194°F

Pressure Ratio: Recommended: $P_2:P_0 = 2.5:1$
 Maximum: $P_2:P_0 = 4:1$

Special Modifications: Diaphragms for working temperatures from -60°F ⇒ 180°F

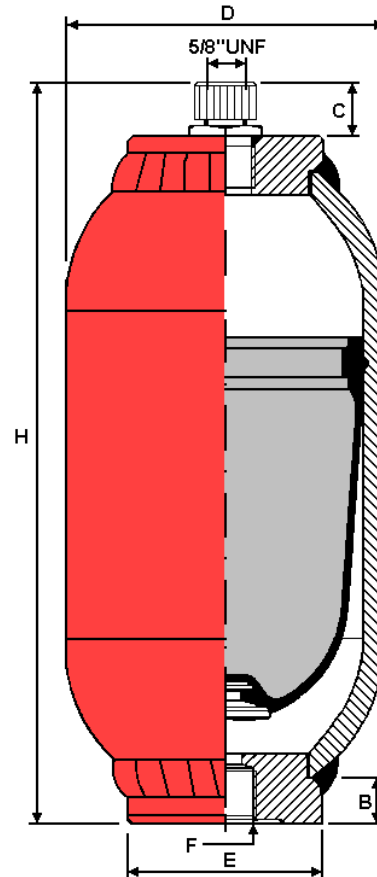

| Part No. ADA-H | Gas Volume cu. in. (Liters) | Max. W.P. PSI (bar) | Weight lbs. (Kg.) | Max. Flow gpm (l/min) | Dimensions, inch (mm) | | | | | Hydraulic Ports |
|-------------------|-----------------------------------|---------------------------|-------------------------|-----------------------------|-----------------------|---------------|--------------|--------------|--------------|---------------------|
| | | | | | H | D | E | C | B | F Size (Thread) |
| 10CI | 9.2 (0.15) | 3625 (250) | 2.6 (1.2) | 10.6 (40) | 5.59 (142) | 2.76 (70) | 1.77 (45) | 0.91 (23) | 0.59 (15) | SAE #8 (3/4"-16) |
| 20CI | 21.4 (0.35) | 3625 (250) | 3.8 (1.7) | 9.2 (35) | 8.07 (205) | 2.76 (70) | 1.38 (35) | 0.91 (23) | 0.59 (15) | SAE #8 (3/4"-16) |
| 25CI | 27.5 (0.45) | 3625 (250) | 4.2 (1.9) | 13.2 (50) | 6.57 (167) | 3.62 (92) | 2.17 (55) | 0.91 (23) | 0.67 (17) | SAE #8 (3/4"-16) |
| 40CI | 42.7 (0.7) | 3625 (250) | 6.0 (2.7) | 10.6 (40) | 8.66 (220) | 3.62 (92) | 1.57 (40) | 0.91 (23) | 0.67 (17) | SAE #8 (3/4"-16) |
| 60CI | 61.0 (1.0) | 3625 (250) | 7.7 (3.5) | 13.2 (50) | 7.87 (200) | 4.53 (115) | 2.36 (60) | 0.91 (23) | 0.75 (19) | SAE #8 (3/4"-16) |
| 85CI | 85.4 (1.4) | 3625 (250) | 10.8 (4.9) | 10.6 (40) | 10.63 (270) | 4.53 (115) | 2.36 (60) | 0.91 (23) | 0.75 (19) | SAE #8 (3/4"-16) |
| 120CI | 122 (2.0) | 3625 (250) | 12.8 (5.8) | 10.6 (40) | 13.78 (350) | 4.53 (115) | 2.36 (60) | 0.91 (23) | 0.75 (19) | SAE #8 (3/4"-16) |
| 1GAL | 231 (3.8) | 3045 (210) | 30.9 (14) | 21.1 (80) | 12.60 (320) | 6.69 (170) | 3.74 (95) | 0.91 (23) | 0.59 (15) | 3/4" BSP |

All dimensions subject to change without notice.

DIAPHRAGM ACCUMULATORS



Specification No. ADA-HST

TECHNICAL

Maximum Working Pressure: 4350 psi
Test Pressure: 6525 psi
Nominal Capacities: 5, 20, 30, 50, 80, 90, 140 cu.in.

DESIGN

Body: Forged steel machined and externally painted black. The accumulator body and cap consists of a special thread that results in the two halves to be normally self-locking under pressure. An optional body construction with Zinc Dichromate plating, internally and externally, is available by adding a T to the end of the part number.

Gas Valve: Standard: SCA-162, $P_{max} = 4350$ psi
 Optional: SCA-53, $P_{max} = 3000$ psi

Diaphragm: Buna-N (Alternatives Available)

Installation: Mounted in any position.

Working Temperatures: $5^{\circ}\text{F} \Rightarrow 194^{\circ}\text{F}$

Pressure Ratio: Recommended: $P_2:P_0 = 2.5:1$
 Maximum: $P_2:P_0 = 6:1$

Special Modifications: Diaphragms for working temperatures from $-60^{\circ}\text{F} \Rightarrow 300^{\circ}\text{F}$

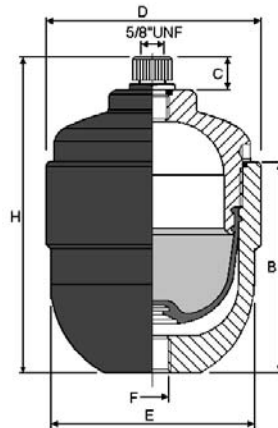

Fig. 1

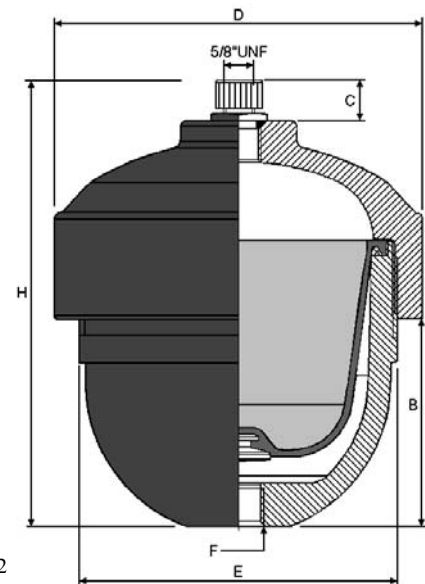

Fig. 2

| Part No. ADA-HST | Gas Volume cu. in. (Liters) | Max. W.P. PSI (bar) | Weight lbs. (Kg.) | Max. Flow gpm (l/min) | Dimensions, inch (mm) | | | | | Hydraulic Ports F Size (Thread) | Figure No. |
|---------------------|-----------------------------------|---------------------------|-------------------------|-----------------------------|-----------------------|---------------|---------------|--------------|---------------|---------------------------------------|------------|
| | | | | | H | D | E | C | B | | |
| 5CI | 7 (0.12) | 4350 (300) | 4.6 (2.1) | 11.9 (45) | 5.55 (141) | 3.11 (79) | 2.95 (75) | 0.91 (23) | 3.58 (91) | SAE #8 (3/4"-16) | 1 |
| 20CI | 21 (0.35) | 4350 (300) | 7.1 (3.2) | 13.2 (50) | 6.02 (153) | 3.90 (99) | 3.74 (95) | 0.91 (23) | 3.58 (91) | SAE #8 (3/4"-16) | 1 |
| 30CI | 30 (0.5) | 4350 (300) | 11.0 (5.0) | 15.9 (60) | 6.30 (160) | 4.88 (124) | 4.53 (115) | 0.91 (23) | 4.21 (107) | SAE #8 (3/4"-16) | 1 |
| 50CI | 49 (0.8) | 4350 (300) | 12.8 (5.8) | 15.9 (60) | 7.09 (180) | 5.43 (138) | 4.72 (120) | 0.91 (23) | 3.03 (77) | SAE #8 (3/4"-16) | 2 |
| 80CI | 80 (1.3) | 4350 (300) | 17.5 (7.9) | 14.5 (55) | 9.06 (230) | 4.88 (124) | 4.53 (115) | 0.91 (23) | 7.68 (195) | SAE #8 (3/4"-16) | 1 |
| 90CI | 92 (1.5) | 4350 (300) | 19.2 (8.7) | 14.5 (55) | 10.63 (270) | 5.43 (138) | 4.72 (120) | 1.91 (23) | 6.69 (170) | SAE #8 (3/4"-16) | 2 |
| 140CI | 140 (2.3) | 4350 (300) | 23.2 (10.5) | 14.5 (55) | 14.17 (360) | 5.43 (138) | 4.72 (120) | 0.91 (23) | 6.69 (170) | SAE #8 (3/4"-16) | 2 |

All dimensions subject to change without notice

HL Hydraulic, Inc.

P.O. Box 450 • Seneca, PA 16346 • Phone 814-677-4086 • Toll Free 877-677-4086 • Fax 814-677-4087
 Website: www.hlhydraulic.com • E-mail: sales@hlhydraulic.com

DIAPHRAGM ACCUMULATORS



Specification No. ADA-HSTPVC ADA-HSTP

TECHNICAL

Maximum Working Pressure: 145 psi
Test Pressure: 217 psi
Nominal Capacities: 5, 20, 40, 50, 90, 140, 300, 600 cu.in.

DESIGN

Body: PVC or Polypropylene constructed in two parts and joined with a special thread that under conditions of dynamic pressure tends to self-lock.

Diaphragm: Buna-N (Standard), Butyl, Nitrile, Polyurethane, EPDM, Viton, PVC, Hytrel, Alcryn

Installation: Mounted in any position.

Max. Working Temperatures: 122°F (PVC)
158°F (Polypropylene)

Pressure Ratio: Recommended: $P_2:P_0 = 2.5:1$
Maximum: $P_2:P_0 = 6:1$

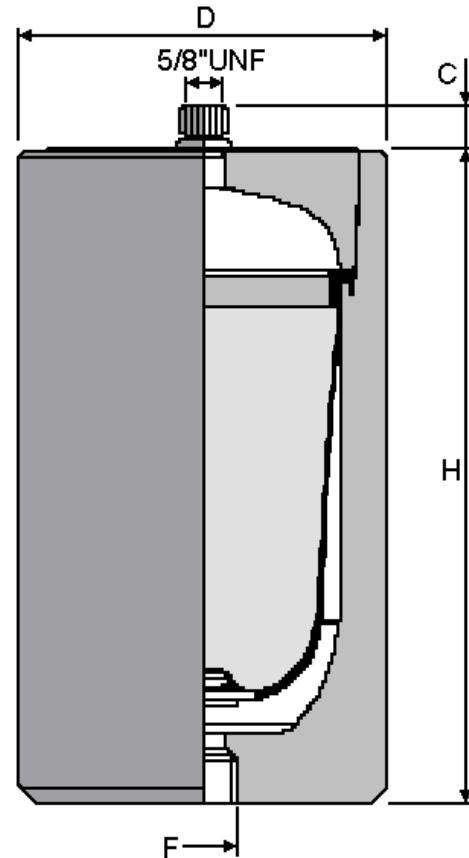

| Part No. ADA-HSTPVC | Part No. ADA-HSTP | Gas Volume cu. in. (Liters) | Max. W.P. PSI (bar) | Weight lbs. (Kg.) | Dimensions, inch (mm) | | | Hydraulic Ports F Size (Thread) |
|------------------------|----------------------|-----------------------------------|---------------------------|-------------------------|-----------------------|---------------|--------------|---------------------------------------|
| | | | | | H | D | C | |
| 5CI | 5CI | 7 (0.12) | 145 (10) | 2.6 (1.2) | 5.43 (138) | 3.15 (80) | 0.91 (23) | SAE #6 (9/16"-18) |
| 20CI | 20CI | 21 (0.35) | 145 (10) | 4.0 (1.8) | 6.10 (155) | 3.94 (100) | 0.91 (23) | SAE #8 (3/4"-16) |
| 40CI | 40CI | 43 (0.7) | 145 (10) | 5.3 (2.4) | 8.07 (205) | 3.94 (100) | 0.91 (23) | SAE #8 (3/4"-16) |
| 50CI | 50CI | 49 (0.8) | 145 (10) | 8.6 (3.9) | 7.09 (180) | 5.51 (140) | 0.91 (23) | SAE #8 (3/4"-16) |
| 90CI | 90CI | 92 (1.5) | 145 (10) | 13.2 (6.0) | 10.63 (270) | 5.51 (140) | 1.91 (23) | SAE #12 (1 1/16"-12) |
| 140CI | 140CI | 140 (2.3) | 145 (10) | 22.0 (10.0) | 14.17 (360) | 5.51 (140) | 0.91 (23) | SAE #12 (1 1/16"-12) |
| 300CI | 300CI | 305 (5) | 145 (10) | 39.7 (18.0) | 16.93 (430) | 7.87 (200) | 0.91 (23) | SAE #24 (1 7/8"-12) |
| 600CI | 600CI | 610 (10) | 145 (10) | 57.3 (26) | 16.93 (730) | 7.87 (200) | 0.91 (23) | SAE #32 (2 1/2"-12) |

All dimensions subject to change without notice

DIAPHRAGM ACCUMULATORS



Specification No. ADA-HSTX

TECHNICAL

Max. Working Pressure: 2175 / 3045 psi
On special request Working Pressure up to 7250 psi.

Test Pressure: 3250 / 4400 psi,
Nominal Capacities: 5, 20, 30, 40, 50, 90, 140,
275, 600 cu.in.

DESIGN

Body: 316 stainless steel, constructed in two parts and joined with a special thread that under conditions of dynamic pressure tends to self-lock. Constructed in accordance with ASME Sec. VIII, Div. 1

Diaphragm Available: Buna-N (Standard), Viton, Butyl, EPDM, Nitrile, etc.

Installation: Mounted in any position.

Pressure Ratio: Recommended: $P_2:P_0 = 2.5:1$
Maximum: $P_2:P_0 = 4:1$

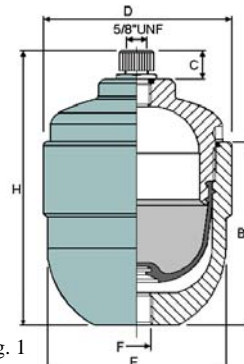

Fig. 1

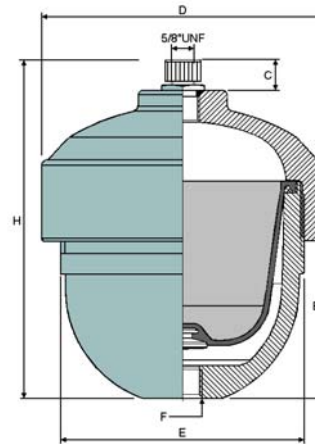

Fig. 2

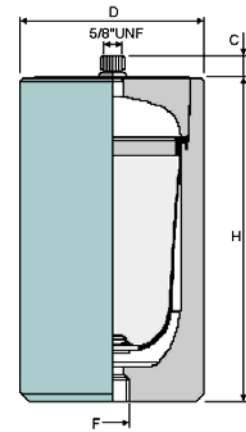

Fig. 3

| Part No. ADA | Gas Volume cu. in. (Liters) | Max. W.P. PSI (bar) | Weight lbs. (Kg.) | Dimensions, inch (mm) | | | | | Hydraulic Ports F Size (Thread) | Figure No. |
|-----------------|-----------------------------------|---------------------------|-------------------------|-----------------------|---------------|---------------|--------------|---------------|---------------------------------------|------------|
| | | | | H | D | E | C | B | | |
| HSTX-5CI | 6 (0.1) | 2175/3045 (150/210) | 4.9 (2.2) | 5.43 (138) | 3.11 (79) | 2.95 (75) | 0.91 (23) | 3.58 (91) | BSP #6 (3/8-19) | 1 |
| HSTX- 20CI | 21 (0.35) | 2175/3045 (150/210) | 8.2 (3.7) | 6.10 (155) | 3.94 (100) | 3.70 (94) | 0.91 (23) | 3.82 (97) | BSP #8 (1/2-14) | 1 |
| HSTX-30CI | 30 (0.5) | 2175/3045 (150/210) | 12.2 (5.5) | 6.30 (160) | 4.84 (123) | 4.84 (123) | 0.91 (23) | 4.21 (107) | BSP #8 (1/2-14) | 1 |
| HSTX-40CI | 40 (0.7) | 2175/3045 (150/210) | 11.1 (5) | 8.07 (205) | 3.94 (100) | 3.70 (94) | 0.91 (23) | 6.30 (160) | BSP #8 (1/2-14) | 1 |
| HSTX-50CI | 49 (0.8) | 2175/3045 (150/210) | 13.5 (6.1) | 7.09 (180) | 5.43 (138) | 4.72 (120) | 0.91 (23) | 3.03 (77) | BSP #8 (1/2-14) | 2 |
| HSTX-90CI | 92 (1.5) | 2175/3045 (150/210) | 19.2 (8.7) | 10.63 (270) | 5.43 (138) | 4.72 (120) | 0.91 (23) | 6.69 (170) | BSP #12 (3/4"-14) | 2 |
| HSTX-140CI | 140 (2.3) | 2175/3045 (150/210) | 23.2 (10.5) | 14.17 (360) | 5.43 (138) | 4.72 (120) | 0.91 (23) | 6.69 (170) | BSP #12 (3/4"-14) | 2 |
| HSTX-275CI | 275 (4.5) | 2175/3045 (150/210) | 53.0 (27) | 14.57 (370) | 7.09 (180) | 7.09 (180) | 0.71 (18) | - (18) | BSP #12 (3/4"-14) | 3 |
| HSTX-600CI | 610 (10) | 2175/3045 (150/210) | 100.0 (45) | 29.13 (740) | 7.09 (180) | - (180) | 0.71 (18) | - (18) | BSP #20 (1 1/4"-11) | 3 |

All dimensions subject to change without notice

HL Hydraulic, Inc.

P.O. Box 450 • Seneca, PA 16346 • Phone 814-677-4086 • Toll Free 877-677-4086 • Fax 814-677-4087
Website: www.hlhydraulic.com • E-mail: sales@hlhydraulic.com

DIAPHRAGM ACCUMULATORS



CHARGING ASSEMBLY

Specification No. SCA-160

TECHNICAL

The precharge valve is an essential device for filling and checking nitrogen precharge in accumulators. Made of plated carbon steel, this valve can be used for a maximum working pressure of 350 Bar. It is supplied in a special case that includes a pressure gauge and 7 foot of hose for connection to the nitrogen bottle.

INSTRUCTION FOR USE

How To Check Nitrogen Pressure:

- If the accumulator is connected to the system, please check that there is no pressure on the oil side. Turn the valve control knob counterclockwise until it is fully disengaged and install it on the accumulator.
- Close the nitrogen discharge valve and turn the "AR" valve knob clockwise until the pressure gauge signals there that there is no internal pressure left or the knob is fully turned clockwise in the event that the accumulator is fully discharged.
- Once the nitrogen pressure is checked, slowly unscrew the discharge valve until the pressure starts decreasing. Once the desired nitrogen pressure is reached, fully unscrew the control valve knob, and open the nitrogen discharge valve to eliminate any residual pressure and then unscrew the "AR" valve from the accumulator and re-install the protective cap of the nitrogen valve on accumulator. Be sure that the protective cap is tightened securely.

Filling Of Nitrogen: Repeat the above mentioned operations connecting the nitrogen bottle quick release coupling before opening the control valve knob. Start filling the nitrogen very slowly. We recommend the use of a gas pressure reducing valve installed on the bottle in order to avoid over-pressurization of the accumulator body during the filling operation, especially when the precharge pressure is low. Check nitrogen precharge approximately every six months.

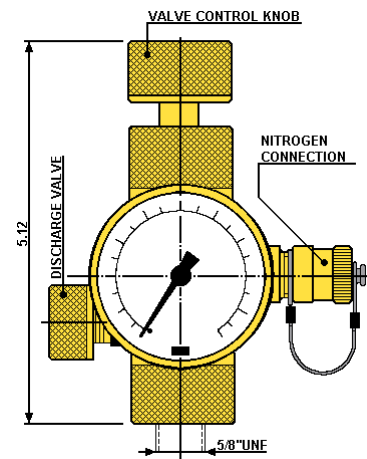

GAS VALVE

Specification No. SCA-162

TECHNICAL

The SCA-162 type valves mounted on our accumulators are made of plated carbon steel and can be used at a maximum working pressure of 400 Bar. In addition to their use on accumulators, they are a safety device for use on pressure vessels for various other applications of filling or controlling of a gas/fluid charge. These valves can also be used for an air drain on closed loop systems. They are also available in AISI 303 stainless steel.

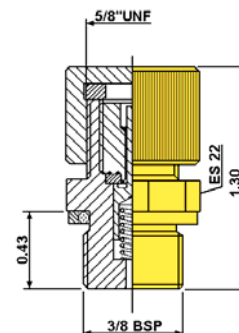

BLADDER TYPE PULSATION DAMPENER



Specification No. HBX

TECHNICAL

Max. Working Pressure: See Data Below
Test Pressure: See Data Below
Nominal Capacities: 1.3, 2.5, 5, & 6.5 Gallon

DESIGN

Body: 316 stainless steel, constructed in three parts and joined with a special thread that under conditions of dynamic pressure tends to self-lock. Constructed in accordance with ASME Sec. VIII, Div. 1

Bladders Available: Buna-N, Butyl, Nitrile, Vamac, Silicone, Hypalon, Polyurethane, EPDM, etc.

Installation: Mounted in vertical position with the gas valve on top.

Pressure Ratio: Recommended: $P_2:P_0 = 2.5:1$
 Maximum: $P_2:P_0 = 4:1$

* Note: the number of cycles is inversely proportional to the increase of the compression ratio.

For pulsation dampener applications the nitrogen precharge must be from 60% to 80% of the working pressure.

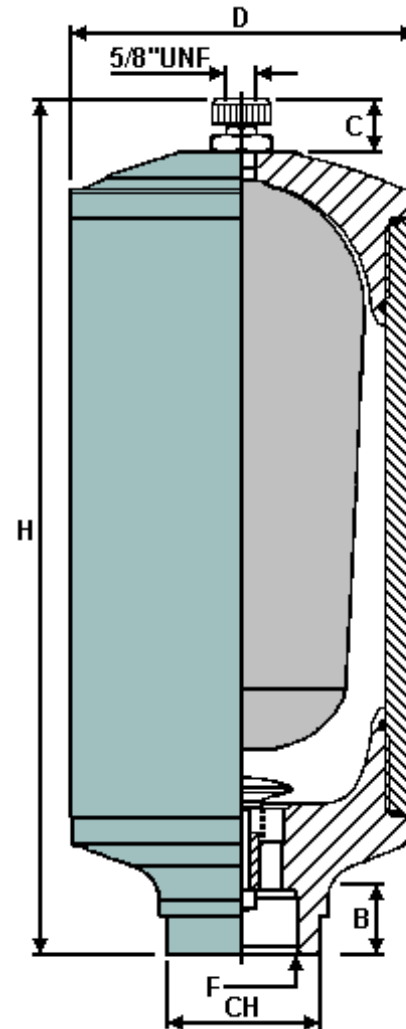

| Part No. | Gas Volume cu. in. (Liters) | Max. W.P. PSI (bar) | Test Press. PSI (bar) | Weight lbs. (Kg.) | Max. Flow gpm (l/min) | Dimensions, inch (mm) | | | | | Hydraulic Ports F Size (Thread) |
|------------|-----------------------------------|---------------------------|-----------------------------|-------------------------|-----------------------------|-----------------------|---------------|--------------|--------------|---------------|---------------------------------------|
| | | | | | | H | D | CH | C | B | |
| HBX-1.3gal | 305 (5) | 3045 (20) | 4567 (315) | 55.1 (25) | 47.5 (180) | 31.50 (800) | 4.92 (125) | 2.56 (65) | 1.38 (35) | 2.36 (60) | 1 1/4" NPT |
| HBX-2.5gal | 610 (10) | 3045 (210) | 4567 (315) | 108.0 (49) | 97.7 (370) | 29.13 (740) | 7.09 (180) | 3.15 (80) | 1.38 (35) | 2.36 (60) | 2" NPT |
| HBX-5gal | 1129 (18.5) | 2175 (150) | 3262 (225) | 165.4 (75) | 132.1 (500) | 33.46 (850) | 8.66 (220) | 3.86 (98) | 1.77 (45) | 3.94 (100) | 3" NPT |
| HBX-6.5gal | 1520 (24.9) | 2175 (150) | 3262 (225) | 198.4 (90) | 145.3 (550) | 39.76 (1010) | 8.66 (220) | 3.86 (98) | 1.77 (45) | 3.94 (100) | 3" NPT |

All dimensions subject to change without notice

HL Hydraulic, Inc.

P.O. Box 450 • Seneca, PA 16346 • Phone 814-677-4086 • Toll Free 877-677-4086 • Fax 814-677-4087
 Website: www.hlhydraulic.com • E-mail: sales@hlhydraulic.com

BLADDER TYPE PULSATION DAMPENER



Specification No. HTRX
BXT

Top Repairable

TECHNICAL

Max. Working Pressure: See Data Below
Test Pressure: See Data Below
Nominal Capacities: HTRX: 0.4 & 1.2 Gallon
 BXT: 2.5, 5, & 6.5 Gallon

DESIGN

Body: 316 stainless steel, constructed in three parts welded together. Constructed in accordance with ASME Sec. VIII, Div. 1

Bladders Available: Buna-N, Butyl, Nitrile, Vamac, Silicone, Hypalon, Polyurethane, EPDM, etc.

Installation: Mounted in vertical position with the gas valve on top.

Pressure Ratio: Recommended: $P_2:P_0 = 2.5:1$
 Maximum: $P_2:P_0 = 4:1$

* Note: the number of cycles is inversely proportional to the increase of the compression ratio.

For pulsation dampener applications the nitrogen precharge must be from 60% to 80% of the working pressure.

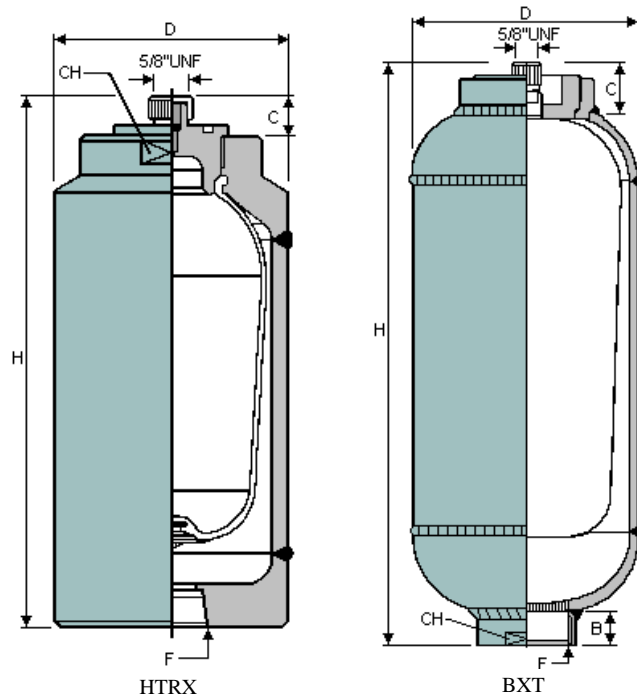

| Part No. ADA | Gas Volume cu. in. (Liters) | Max. W.P. PSI (bar) | Test Press. PSI (bar) | Weight lbs. (Kg.) | Max. Flow gpm (l/min) | Dimensions, inch (mm) | | | | | Hydraulic Ports |
|-----------------|-----------------------------------|---------------------------|-----------------------------|-------------------------|-----------------------------|-----------------------|---------------|--------------|--------------|--------------|--------------------|
| | | | | | | H | D | CH | C | B | F Size (Thread) |
| HTRX-0.4gal | 92 (1.5) | 1015 (70) | 1523 (105) | 14.80 (6.7) | 39.6 (150) | 10.63 (270) | 4.49 (114) | 3.15 (80) | 0.79 (20) | - - | 1" NPT |
| HTRX- 1.2gal | 275 (4.5) | 725 (50) | 1088 (75) | 22.0 (10) | 52.8 (200) | 13.78 (350) | 6.61 (168) | 3.54 (90) | 1.77 (45) | - - | 1 1/2" NPT |
| BXT-2.5gal | 610 (10) | 725 (50) | 1088 (75) | 35.3 (16) | 47.5 (180) | 29.92 (760) | 6.61 (168) | 2.76 (70) | 1.57 (40) | 1.73 (44) | 2" BSP |
| BXT-5gal | 1129 (18.5) | 435 (30) | 652 (45) | 57.3 (26) | 52.8 (200) | 29.13 (740) | 8.66 (220) | 3.70 (94) | 2.36 (60) | 2.05 (52) | 3" BSP |
| BXT-6.5gal | 1520 (24.9) | 435 (30) | 652 (45) | 66.2 (31) | 47.5 (180) | 35.04 (890) | 8.66 (220) | 3.70 (94) | 2.36 (60) | 2.05 (52) | 3" BSP |

All dimensions subject to change without notice

ACCUMULATOR SPECIAL EXECUTIONS



TECHNICAL

The catalog does not include all of the special modifications that are available from SCHRUPP. We recommend therefore that you contact our technical office concerning any special request, which cannot be satisfied by our standard product.

Following is a list of a few examples of special products already manufactured by SCHRUPP:

- Special flanges per request.
- Accumulators for very high pressures (7000-14000 psi) both in carbon steel and stainless steel.
- Accumulators in preheat vapor chambers
- Accumulators for pulsation dampening in both carbon steel and stainless steel.
- Accumulators manufactured in polypropylene and nylon.
- Accumulators manufactured in hastelloy.
- Inline silencers without elastomers for aggressive fluids.
- Inline silencers without elastomers for extremely high temperature fluids.
- Inline silencers with elastomers without precharge pressure.
- P.T.F.E. diaphragm dampers with stainless steel, PVC or polypropylene construction.

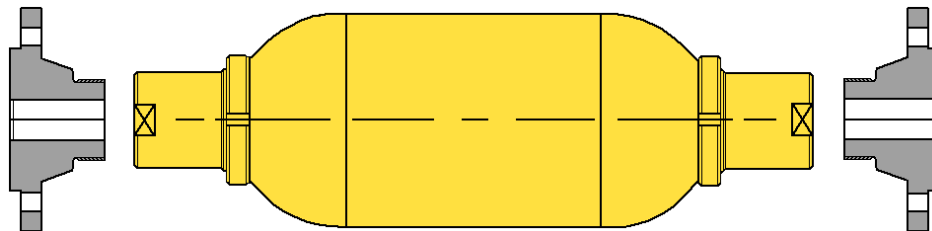
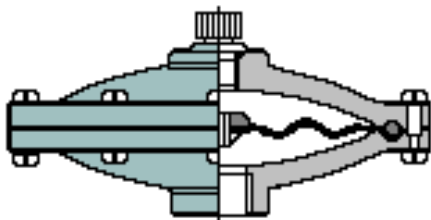
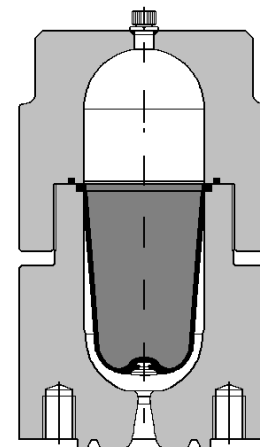
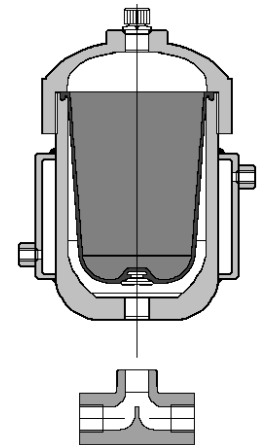
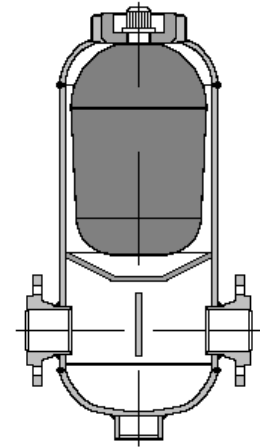

HL Hydraulic, Inc.

P.O. Box 450 • Seneca, PA 16346 • Phone 814-677-4086 • Toll Free 877-677-4086 • Fax 814-677-4087 Website: www.hlhydraulic.com • E-mail: sales@hlhydraulic.com