



R8M

O

N

O

1

DISPLACEMENT

Italgroup[®]

HYDRAULIC MOTORS

● ● ● ITALY

SINGLE DISPLACEMENT HYDRAULIC MOTOR



R8M SERIES TECHNICAL CATALOGUE

The data specified into the catalogue are for product description purpose only and must not be interpreted as warranted characteristics in legal sense. ItalgrouP S.r.l. reserves the right to implement modifications without notice.

All partial or total reproduction and copy without written authorization of ItalgrouP S.r.l. is strictly forbidden.

©2018 ITALGROUP S.R.L. - ALL RIGHTS RESERVED -

GENERAL INDEX

FORMULAS	Pag. 3
INTRODUCTION - GENERAL INFORMATION	Pag. 4 - 5
MOTOR TECHNICAL DATA	Pag. 6 - 7
INTERCHANGEABILITY CHART	Pag. 8
R8M ORDERING CODE	Pag. 9
HYDRAULIC FLUID RECOMMENDATIONS	Pag. 10 - 11
DRAIN RECOMMENDATIONS - FLUSHING	Pag. 12 - 13
STANDARD SHAFT SEAL FEATURES	Pag. 14 - 15
MOTOR INSTALLATION AND STARTUP	Pag. 16 - 18
MOTOR HANDLING AND STORAGE	Pag. 19 - 20
MAINTENANCE OPERATION	Pag. 21
INSTRUCTION AND ADVICES	Pag. 22
SPECIAL FEATURES	Pag. 23
TROUBLESHOOTING	Pag. 24 - 25
UNIT CONVERSIONS	Pag. 26
R8M H1	Pag. 27 - 45
R8M H2	Pag. 47 - 70
R8M H3	Pag. 71 - 91
R8M H4	Pag. 93 - 110
R8M H45	Pag. 111 - 119
R8M H5	Pag. 121 - 139
R8M H55	Pag. 141 - 149
R8M H6	Pag. 151 - 162
R8M H7	Pag. 163 - 177
MOTOR DISTRIBUTORS	Pag. 178 - 179
TACHOMETERS	Pag. 180 - 184
SPLINED BILLETS - SPLINED BARS	Pag. 185 - 189
ADAPTOR FLANGES	Pag. 190 - 191
VALVES	Pag. 193 - 210
CONTACT US - REACH US	Pag. 211

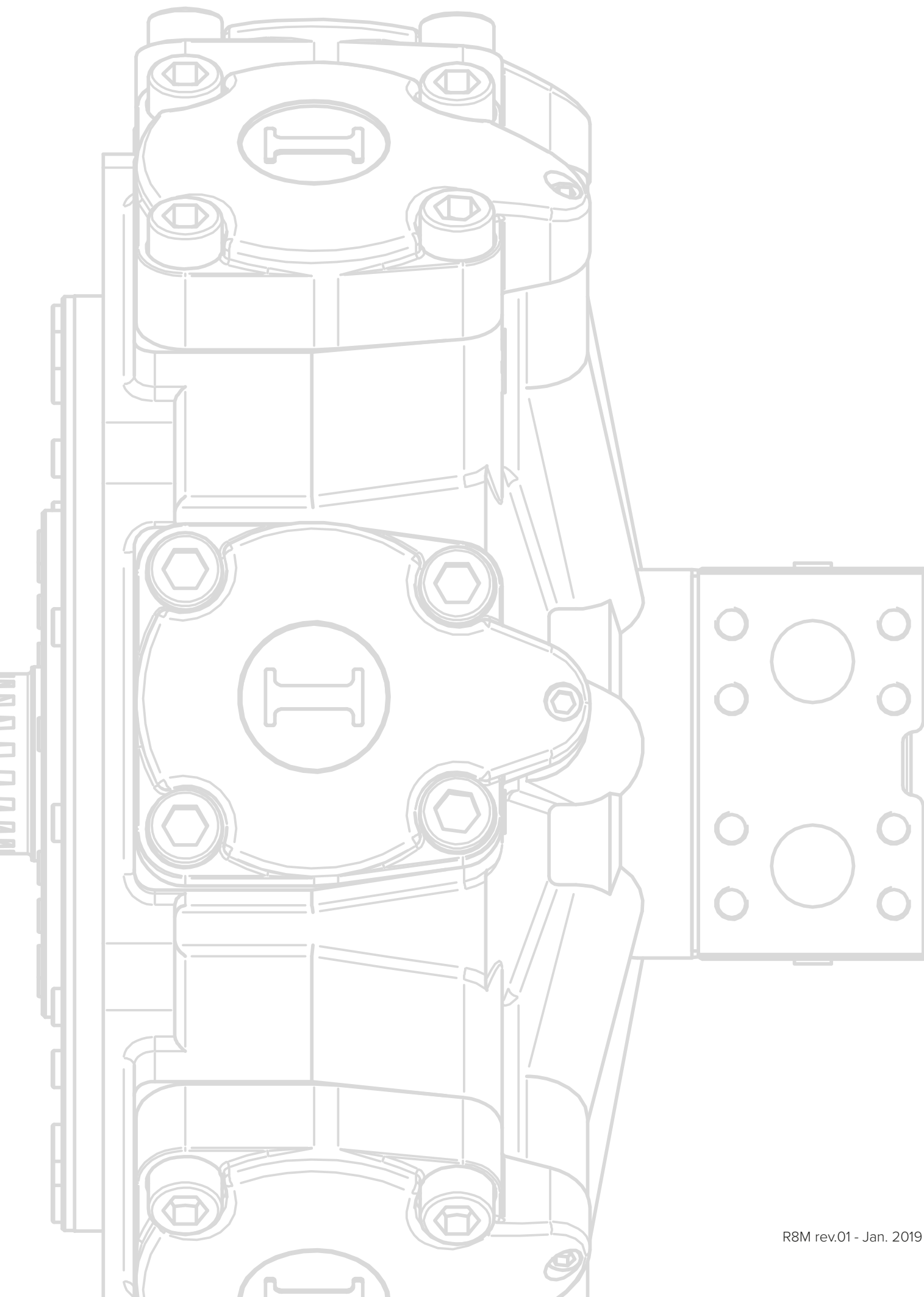

FORMULAS

$$\text{Torque [Nm]} = \text{Specific torque [Nm/bar]} * \text{Pressure [bar]}$$

$$\text{Torque [Nm]} = \frac{\text{Displacement [cc/Rev]} * \text{Pressure [bar]}}{62.8}$$

$$\text{Power [kW]} = \frac{\text{Torque [Nm]} * \text{Speed [rpm]}}{9549}$$

$$\text{Power [CV]} = \frac{\text{Torque [Nm]} * \text{Speed [rpm]}}{7023}$$

$$\text{Speed [rpm]} = \frac{\text{Flow [l/min]} * 1000}{\text{Displacement [cc/Rev]}}$$

$$\text{Displacement [cc/Rev]} = \frac{\text{Torque [Nm]} * 62,8}{\text{Pressure [bar]}}$$

$$\text{Flow [l/min]} = \frac{\text{Displacement [cc/Rev]} * \text{Speed [rpm]}}{1000}$$

INTRODUCTION

GENERAL INFORMATION

Carefully read the use and maintenance manual before start-up the motor. The use and maintenance manual must be placed near to motor installation location in order to guarantee operators easy access to the instruction manual. For further information please contact ItalgrouP.

MOTOR DESCRIPTION

R8M series motors are radial piston hydraulic motors (generally indicated as LSHT motors, low speed high torque motors) with a rotating shaft (1) and a stationary housing (2). The pistons (4) are located radially and the working fluid provide the mechanical force that push the pistons against the eccentric shaft, providing the shaft output torque. The inlet and outlet flow to and from the pistons is regulated by a distributor (5), that provides the oil distribution correct timing. The pistons transfer the forces to the eccentric shaft through a connecting rod (3). Acting in the adequate way (increasing or reducing the oil flow coming from the pump) the motor rotational speed can be increased or reduced. The motor design guarantee extremely high starting torque and high mechanical working efficiency. Respecting the limitation of working parameters (indicated into the technical datasheets) and all recommendations (including fluid recommendations), high motor lifetimes are obtained and very low maintenance requirements are needed.

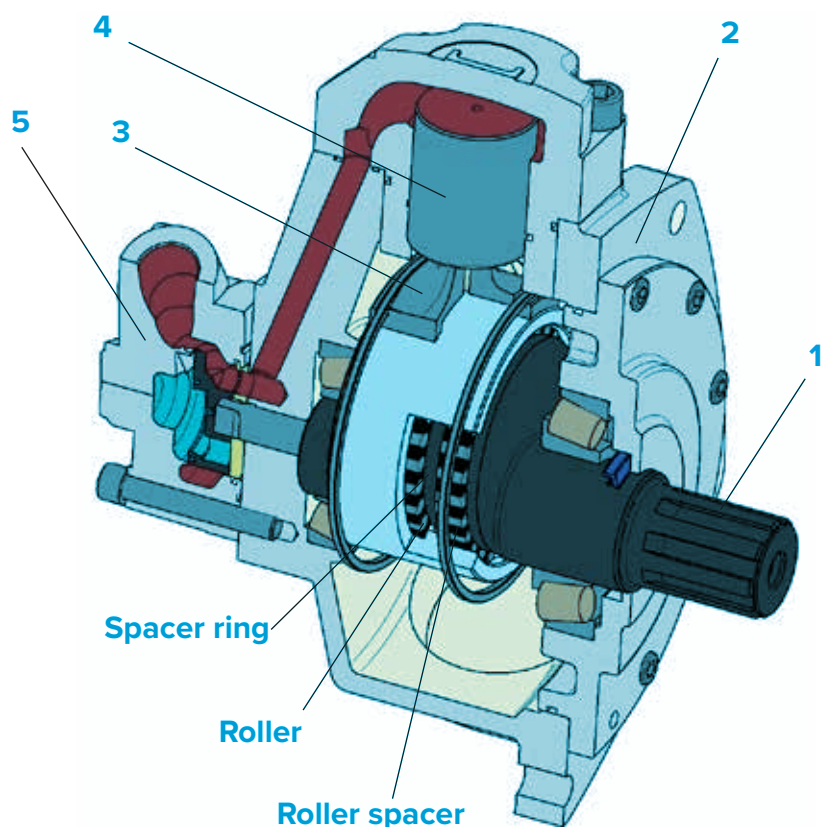

TECHNICAL INNOVATION ON R8M H45, H5, H55, H6 AND H7 SERIES

Special bearing construction to prevent from seizure of the connecting rod with the external bushing. This could happen in high speed and high pressure working conditions and could lead to motor breakdown.

The new bearing design consists of:

- roller spacers, with function of
 - keeping rollers axis parallel
 - creating space between rollers to hold more oil
- spacer rings, with function of
 - keeping rollers lined up
 - absorbing axial forces coming from connection rod

R8M SERIES

Hydraulic motors of the R8M series are single displacement crankshaft radial piston motors. Thanks to great variety of accessories R8M series can be used in a wide range of applications such as:



- MARINE EQUIPMENTS
- WINCHES
- OFFSHORE EQUIPMENTS
- CONVEYORS
- INJECTION MOLDING MACHINES
- STEEL BENDING MACHINES
- FORK LIFTS TRUCKS
- SKID STEER LOADERS
- DUMPERS
- AGRICULTURAL AND FORESTRY MACHINES
- MUNICIPAL VEHICLES
- AIRPORT MACHINERY

PRODUCT FEATURES:

- ✓ High volumetric and mechanical efficiencies
- ✓ Very smooth running at low speeds
- ✓ High starting torque / constant torque
- ✓ Wide speed range
- ✓ Compact Design
- ✓ Low maintenance and high reliability
- ✓ Bi-directional
- ✓ High radial and axial force allowed
- ✓ Speed sensor available
- ✓ Built-in valves available

MOTOR TECHNICAL DATA

Motor	Size	Displacement	Theoretical torque	Max cont. pressure	Max cont. speed	Peak speed (**)	Max cont. power (*)	Max power	Dry weight
		[cc]	[Nm/bar]	[bar]	[rpm]	[rpm]	[kW]	[kW]	[kg]
R8M 80	H1	80	1.3	270	950	1050	28	41	26
R8M 100	H1	100	1.6	270	950	1050	28	41	26
R8M 150	H1	157	2.5	270	950	1050	28	41	26
R8M 175	H1	176	2.8	270	800	900	28	41	26
R8M 195	H1	195	3.1	270	800	900	28	41	26
R8M 200	H1	207	3.3	250	750	850	28	41	26
R8M 250	H1	257	4.1	250	750	850	28	41	26
R8M 300	H1	307	4.9	250	750	850	28	41	26
R8M 200	H2	198	3.2	270	800	900	35	50	42
R8M 250	H2	253	4.0	270	750	850	35	50	42
R8M 300	H2	314	5.0	270	750	850	35	50	42
R8M 350	H2	362	5.8	270	650	750	35	50	42
R8M 400	H2	424	6.7	270	600	700	35	50	42
R8M 500	H2	492	7.8	260	500	600	35	50	42
R8M 600	H2	584	9.3	250	500	600	35	50	42
R8M 350	H3	349	5.6	270	630	700	47	70	68
R8M 400	H3	397	6.3	270	600	680	47	70	68
R8M 450	H3	452	7.2	270	600	680	47	70	68
R8M 500	H3	491	7.8	270	600	680	47	70	68
R8M 600	H3	594	9.4	270	550	630	47	70	68
R8M 650	H3	660	10.5	250	500	580	47	70	68
R8M 700	H3	707	11.2	250	450	500	47	70	68
R8M 800	H3	791	12.6	250	400	450	47	70	68
R8M 700	H4	714	11.4	270	500	580	56	82	92
R8M 800	H4	792	12.6	270	450	530	56	82	92
R8M 850	H4	847	13.5	270	450	530	56	82	92
R8M 900	H4	904	14.4	270	450	530	56	82	92
R8M 1000	H4	992	15.8	270	330	400	56	82	92
R8M 1100	H4	1116	17.8	260	330	400	56	82	92
R8M 1200	H4	1192	19.0	250	300	350	56	82	92
R8M 1250	H4	1247	19.8	260	250	300	56	82	92
R8M 1400	H4	1332	21.2	250	230	280	56	82	92
R8M 1100	H45	1183	18.8	270	350	400	85	120	118
R8M 1400	H45	1376	21.9	270	300	350	85	120	118
R8M 1600	H45	1648	26.2	260	275	325	85	120	118
R8M 1800	H45	1815	28.9	250	250	300	85	120	118
R8M 1000	H5	1094	17.4	270	350	400	92	122	173
R8M 1200	H5	1231	19.6	270	300	350	92	122	173

Motor	Size	Displacement [cc]	Theoretical torque [Nm/bar]	Max cont. pressure [bar]	Max cont. speed [rpm]	Peak speed (**) [rpm]	Max cont. power (*) [kW]	Max power [kW]	Dry weight [kg]
R8M 1400	H5	1376	21.9	270	300	350	92	122	173
R8M 1500	H5	1528	24.3	270	300	350	92	122	173
R8M 1600	H5	1648	26.2	270	300	340	92	122	173
R8M 1800	H5	1815	28.9	260	250	300	92	122	173
R8M 2000	H5	2035	32.4	250	230	260	92	122	173
R8M 2200	H5	2220	35.3	250	220	240	92	122	173
R8M 2200	H55	2126	33.8	270	240	280	120	170	203
R8M 2500	H55	2525	40.2	270	240	280	120	170	203
R8M 2800	H55	2807	44.7	260	240	280	120	170	203
R8M 3000	H55	3028	48.2	260	230	270	120	170	203
R8M 2200	H6	2206	35.1	270	220	260	122	172	308
R8M 2500	H6	2525	40.2	270	220	260	122	172	308
R8M 2800	H6	2807	44.7	270	220	260	122	172	308
R8M 3000	H6	2983	47.5	270	210	250	122	172	308
R8M 3200	H6	3289	52.3	260	200	240	122	172	308
R8M 3500	H6	3479	55.4	250	200	240	132	182	308
R8M 3400	H7	3413	54.3	270	180	220	132	182	405
R8M 3600	H7	3650	58.1	270	170	200	132	182	405
R8M 3900	H7	3907	62.2	270	160	200	132	182	405
R8M 4300	H7	4343	69.1	270	150	190	132	182	405
R8M 4600	H7	4616	73.5	270	140	190	132	182	405
R8M 5000	H7	5088	81.0	260	140	180	132	182	405
R8M 5400	H7	5384	85.7	250	130	170	132	182	405
R8M 6000	H8								
R8M 6500	H8								
R8M 6800	H8								
R8M 7600	H8								
R8M 8000	H8								
For R8M H8, please refer to R8D catalogue									
R8M 7000	H9								
R8M 8000	H9								
R8M 9000	H9								
For R8M H9, please refer to R8D catalogue									
R8M 10000	H9								
R8M 11000	H9								
R8M 13000	H9								

For all motors:

- Hydrostatic test pressure: 420 bar

- Refer to motor performance diagrams for more information

- (*) For motor operation with a continuous duty cycle at maximum continuous power the flushing is usually required.

For more information please contact our technical department.

- (**) Do not exceed maximum power.

INTERCHANGEABILITY CHART

Italgrou motor code	Cross reference motor code
R8M 200/B10	HMB 10
R8M 450/B30	HMB 30
R8M 800/B45	HMB 45
R8M 1000 H5 - R8M 1000/B60 H5	HMB 60
R8M 1400 H5 - R8M 1400/B80 H5	HMB 80
R8M 1600 H5 - R8M 1600/B100 H5	HMB 100
R8M 2200 H55	HMB 125
R8M 2200 H6 - R8M 2200/B125 H6	HMB 125
R8M 2500 H6 - R8M 2500/B150 H6	HMB 150
R8M 3000 H6 - R8M 3000/B200 H6	HMB 200
R8M 4600 H7	HMB 270
R8M 5400 H7	HMB 325
R8M 160-190-250/C190 H2	MR 160 - MR 190
R8M 250-300-350-400/C300 H2	MR 250 - MR 300 - MRE 330 - MRA 400
R8M 450-500/C H3	MR 450 - MRE 500
R8M 700-800/C H4	MR 700 - MRE 800
R8M 1100-1400-1600/C H45 R8M 1000-1400-1600/C1100 H5	MR 1100 - MRE 1400 - MRA 1600
R8M 1600-1800-2000/C H5	MR 1600 - MR 1800 - MRE 2100
R8M 2500-2800-3000-3500/C H6	MR 2400 - MR 2800 - MRE 3100 MRA 3500
R8M 3600-4500-5400/C H7	MR 3600 - MR 4500 - MRE 5400
R8M 5000/RM H7	RM 5000
R8M H1/GM05	GM05
R8M H1/GM1	GM1
R8M H2/GM2	GM2
R8M H3/GM3	GM3
R8M H4/GM4	GM4
R8M H5/GM5	GM5
R8M H2/S	M2
R8M H3/S	M3
R8M H4/S	M4

R8M - ORDERING CODE

R8M	--	--	--	--	--	--	--	--
DISPLACEMENT	INTERCHANGEABILITY	SERIE	SHAFT	TACHOMETER	SPECIAL FEATURES			
80 100 150	/GM05 /GM1	H1	A0 A01	TA	MP			
175 195 200	/BH /PH		A1 A11	TB	SPSL			
250 300			A12 A13	TT1	HPS			
See pag. 27-45			A2 A21	TQ1	CCW			
160 190 200	/C190 /C300	H2	A22 A3	EST	See pag. 23			
250 300 350	/GM2 /S		A31 A4	EST30	Z --	Italgroupp internal code		
400 500 600	/PH /B10			EST31				
See pag. 47-70				EST32				
350 400 450	/C /B30	H3		EST33				
500 600 650	/GM3 /S			See pag. 180-184				
700 800	/N							
See pag. 71-91								
700 800 850	/C /B45	H4	DISTRIBUTOR			SPLINED BILLET / SPLINED BAR		
900 1000 1100	/GM4 /S		D31B D31BJ			SB1 SB11		
1200 1250 1400			D36B D36BJ			SB2 SB12		
See pag. 93-110			D310B D310BJ			SB3 SB14		
1100 1400 1600	/C	H45	D40 D40J			SB4 SB15		
1800			D47 D47J			SB5 SB16		
See pag. 112-119			D416 D416J			SB6 SB17		
1000 1200 1400	/C1100 /C	H5	D75 D75J			SB7 SB21		
1500 1600 1800	/B60 /B80		D90 D90J			SB8 SB24		
2000 2200	/B100 /GM5		See pag. 178-179			SB9 SB27		
See pag. 121-139						SB10 SB30		
2200 2500 2800	/C	H55				B8076 B8078		
3000						B8079		
See pag. 141-149						See pag. 185-189		
2200 2500 2800	/C /B125	H6						
3000 3200 3500	/B150 /B200							
See pag. 151-162								
3400 3600 3900	/C /RM	H7						
4300 4600 5000								
5400								
See pag. 163-177								

HYDRAULIC FLUID RECOMMENDATIONS

Fluid selection

In general, we recommend the use of hydraulic oils with minimum viscosity index of 95, with anti-wear additives (ISO HM and HV). Once normal working temperature is reached, the drain oil viscosity must be at least 35-40 cSt, preferably in the range from 40 to 60 cSt.

HE oils (ecological fluids) are allowed, but must be used with particular attention, because they can influence the motor seals compatibility, and can reduce motor performances and life. Please contact us in case of HE oils usage.

Optimal viscosity selection

Referring the first approximated selection to the room temperature, we advice the following:

Room temperature	Oil
-20°C/0°C	BP ENERGOL HLP – HM 22
-15°C/+5°C	BP ENERGOL HLP – HM 32
-8°C/+15°C	BP ENERGOL HLP – HM 46
0°C/+22°C	BP ENERGOL HLP – HM 68
+8°C/+30°C	BP ENERGOL HLP – HM 100
-20°C/+5°C	BP BARTRAN HV 32
-15°C/+22°C	BP BARTRAN HV 46
0°C/+30°C	BP BARTRAN HV 68

ATF (automatic transmission fluid) oils, SAE 10-20-30 W oils, multigrade motor oils (SAE 15 W 40, 10 W 40), universal oils, can also be used. Always fill the motor (please refer to the “DRAIN RECOMMENDATIONS” section) with the selected hydraulic fluid before motor start-up. During cold start-up avoid high-speed operation until the system reach the working temperature, in order to provide an adequate lubrication. Every 5-8 °C of increase respect to the optimal working temperature for the selected oil, the hydraulic fluid life decrease of about 40-50% (refer to “OXIDATION” section). Consequently, the motor lifetime will be affected by the working temperature increase respect to the optimal working temperature of the selected oil. The maximum continuous working temperature is 70 °C, the temperature must be measured from motor drain line. If the motor doesn't have a drain line, the temperature must be evaluated at the return line port.

Fire resistant oil limitations

	Max cont. Pressure [bar]	Max int. Pressure [bar]	Max Speed [rpm]
HFA, 5-95% oil-water	103	138	50%
HFB, 60-40% oil-water	138	172	100%
HFC, water-glycol	103	138	50%
HFD, ester phosphate	250	293	100%

Filtration

Hydraulic systems oil must always be filtered.

The choice of filtration grade derives from needs of service life and money spent. In order to obtain stated service life it is important to follow our recommendations concerning filtration grade.

When choosing the filter it is important to consider the amount of dirt particles that filter can absorb and still operate satisfactorily. For that reason we recommend filters showing when you need to substitute filtering cartridge.

- 25 µm filtration required in most applications
- 10 µm filtration in closed circuit applications

Oxidation

Hydraulic oil oxidizes with time of use and temperature. Oxidation causes changes in colour and smell, acidity increase or sludge formation in the tank. Oxidation rate increases rapidly at surface temperatures above 60°C, in these situations oil should be checked more often.

The oxidation process increases the acidity of the fluid; the acidity is stated in terms of the “neutralization number”. Oxidation is usually slow at the beginning and then it increases rapidly.

A sharp increase (by a factor of 2 to 3) in neutralization number between inspections shows that oil has oxidized too much and should be replaced immediately.

Water content

Oil contamination by water can be detected by sampling from the bottom of the tank. Most hydraulic oils repel the water, which then collects at the bottom of the tank. This water must be drained off at regular intervals. Certain types of transmission oils and engine oils emulsify the water; this can be detected by coatings on filter cartridges or a change in the colour of the oil. In such cases, obtain your oil supplier advice.

Degree of contamination

Heavy contamination of the oil causes wear rising in hydraulic system components. Contamination causes must be immediately investigated and remedied.

Analysis

It is recommended oil being analyzed every 6 months. The analysis should cover viscosity, oxidation, water content, additives and contamination. Most oil suppliers are equipped to analyze oil state and to recommend appropriate action. Oil must be immediately replaced if the analysis shows that it is exhausted.

DRAIN RECOMMENDATIONS

MOTOR AXIS HORIZONTAL

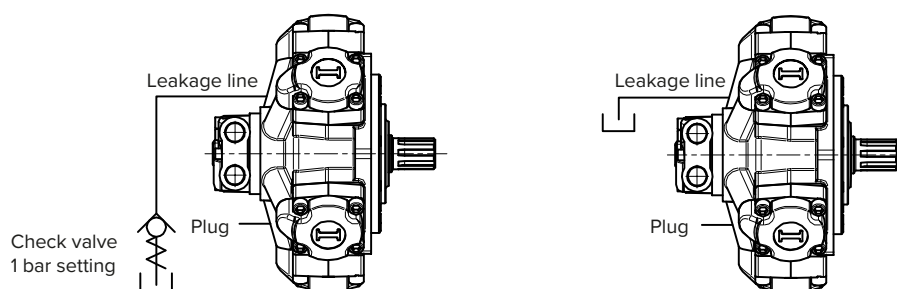

MOTOR AXIS VERTICAL, SHAFT DOWN

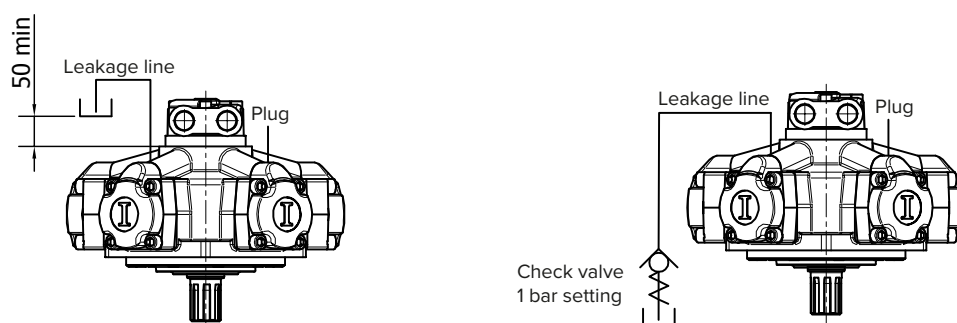

MOTOR AXIS VERTICAL, SHAFT UP

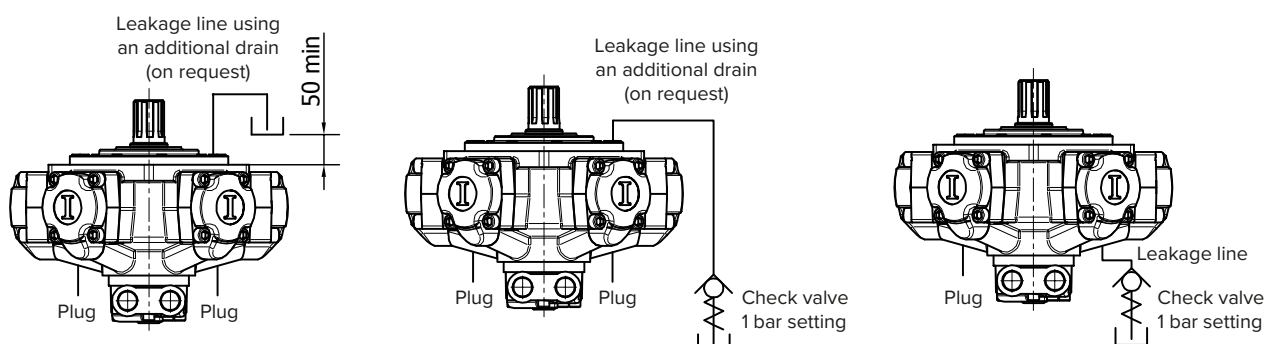

LEAKAGE LINE CONNECTION

Always fill the motor with hydraulic fluid before start-up. Arrange piping in a way that the motor cannot drain off and cannot generate air bubbles into the motor case. Under certain conditions it may be necessary to arrange a check valve in order to help avoid the motor draining off. Always check carefully that the leakage line pressure doesn't overcome 10 bar pressure: therefore leakage lines must be shorter as possible and with a minimum flow resistance.

FLUSHING

Motor	Flushing flow [l/min]
R8M H1 80,100	5
R8M H1 150, 175, 195, 200, 250, 300 R8M H2 200, 250, 300	6
R8M H2 350, 400, 500 R8M H3 350, 400, 450, 500	8
R8M H2 600 R8M H3 600, 650, 700, 800 R8M H4 700, 800, 850, 900, 1000, 1100, 1250, 1400 R8M H5 1000, 1200, 1400, 1500, 1600, 1800, 2000	10
R8M H5 2200 R8M H6 2500, 2800, 3000, 3200, 3500	15
R8M H7 3900, 4300, 4600, 5000, 5400 R8M H8 6000, 6500, 6800, 7600, 8000	20

Important note: the above value are approximated. The correct way to operate is the following: the flushing flow is adequate if during the motor operation the drain oil viscosity be at least 35-40 cSt, preferably in the range from 40 to 60 cSt.

Maximum continuous case pressure 6 bar (10 bar peak pressure). Special seals for 20-25 bar continuous case pressure are available upon request (ordering code: HPS).

FLUSHING OUTLET PORT

Please note: the flushing outlet port must always be located in the highest possible position.

MAXIMUM CASE PRESSURE

6 bar continuous
10 bar peak

For standard R8M motors

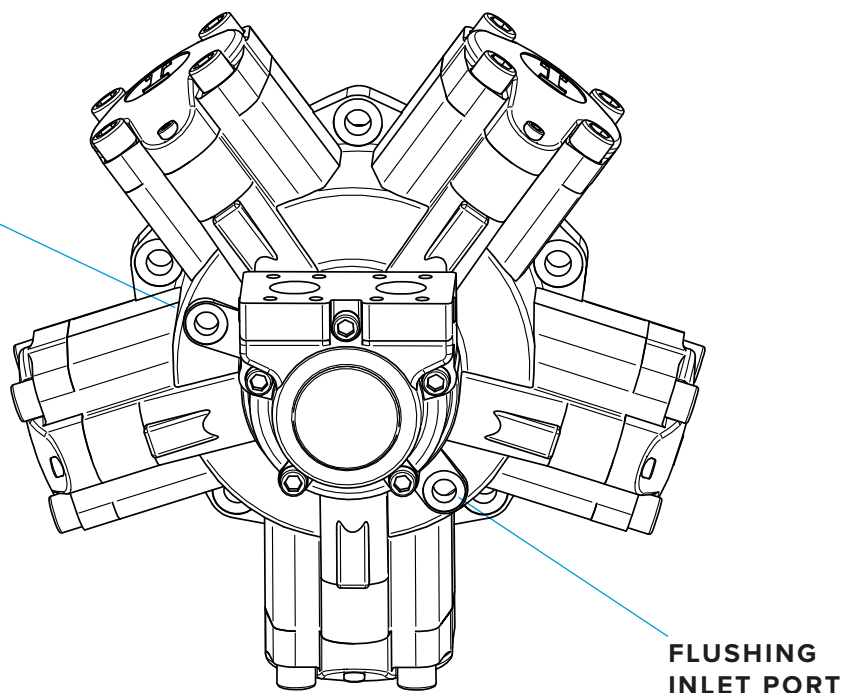

STANDARD SHAFT SEAL FEATURES

Features

Type: BABSL
 Form: AS DIN 3760
 Material: SIMRIT® 72 NBR 902
 SIMRIT® 75 FKM 595

Material

SIMMERRING® radial shaft seal with rubber covered O.D., short, flexibility suspended, spring loaded sealing lip and additional dust lip:
 see Part B/SIMMERRING®, sections 1.1 and 2.

Application

Sealing lip and O.D.:

- Acrylonitrile-butadiene rubber with 72 Shore A hardness (designation: SIMRIT® 72 NBR 902)
- Fluoro rubber with 75 Shore A hardness (designation: SIMRIT® 75 FKM 595)

Metal insert:

- Plain steel DIN 1624

Spring:

- Spring steel DIN 17223

Operating conditions

See Part B/ SIMMERRING®, sections 2. 4.

Media: mineral oils, synthetic oils

Temperature:

- 40°C to +100°C (SIMRIT® 72 NBR 902)
- 40°C to +160°C (SIMRIT® 75 FKM 595)

Surface speed: up to 5 m/s

Working pressure: see diagram on next page, pressure is function of surface speed (i.e. of rotating speed and shaft diameter)

Housing and machining criteria See Part B/ SIMMERRING®, sections 2.

Shaft:
 Tolerance: ISO h11
 Concentricity: IT 8
 Roughness: Ra=0.2-0.8 µm
 Rz=1-4 µm
 Rmax=6 µm
 Hardness: 45-60 HRc
 Roughness: non oriented;
 preferably by plunge grinding

Housing:
 Tolerance: ISO H8
 Roughness: Rmax<25 µm

Pressure diagram

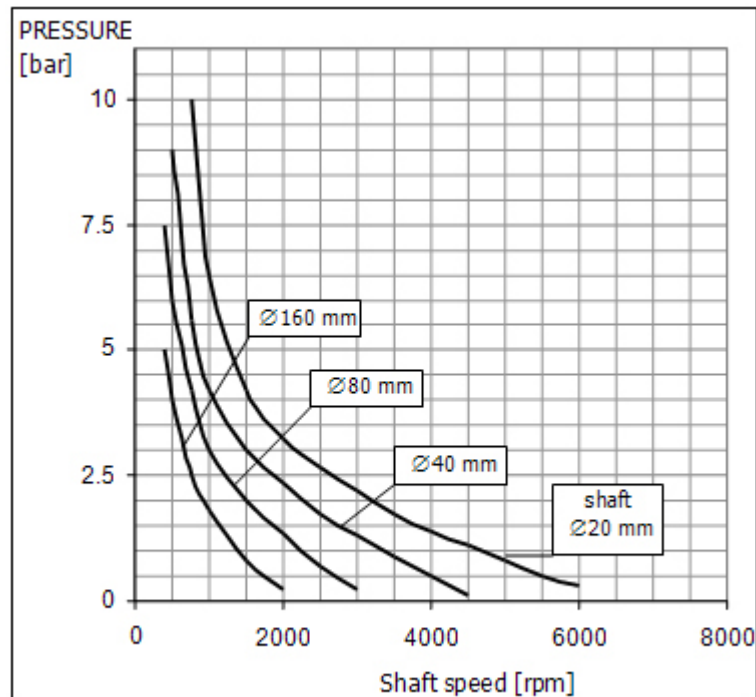

Diagram 1: Pressure Loading Limits

Special seals for 20-25 bar continuous case pressure are available upon request (ordering code: HPS). Refer to page 23 for more information.

MOTOR INSTALLATION AND STARTUP

Motor installation and start-up

The motor, after testing, it's packed in different ways that depends by customer and/or logistic requirements. The motor must be carefully moved from his box or pallet, with the assistance of correctly sized movimentation tools, like eyebolts (all the motors has a thread hole in the shaft end, please refer to the R8M general catalogue, shafts section) or lifting slings.

When the motor is moved from one place to another always be very careful and act in a way that the motor is stable and under control during movimentation (refer to handling and storage section for more details).

Before mount the motor, check carefully the absence of damage happened for example during transportation and/or storing.

For mounting dimensions please refer to the R8M installation drawings. The motor must be installed using the correct screws size (we recommends the use of 10.9 and 12.9 class resistance fixing screws) and must be placed on a structure that is capable to correctly support the motor during functioning: for this reason the structure must not only be able to support the motor weight but must also assure the absence of vibration during operation and must win the reaction forces that are generated by the working torque. Regarding the motor fitting design, the concentricity between the centering diameter (spigot) and shaft (both splined or parallel) must be assured with a strict tolerance (please refer to the following general indication). If the concentricity between the shaft and the centering diameter and/or fixing holes is not respected, in the worst case the motor can have an unusual failure or can work only with low performances. Splined adaptors (splined billets) are available upon request.

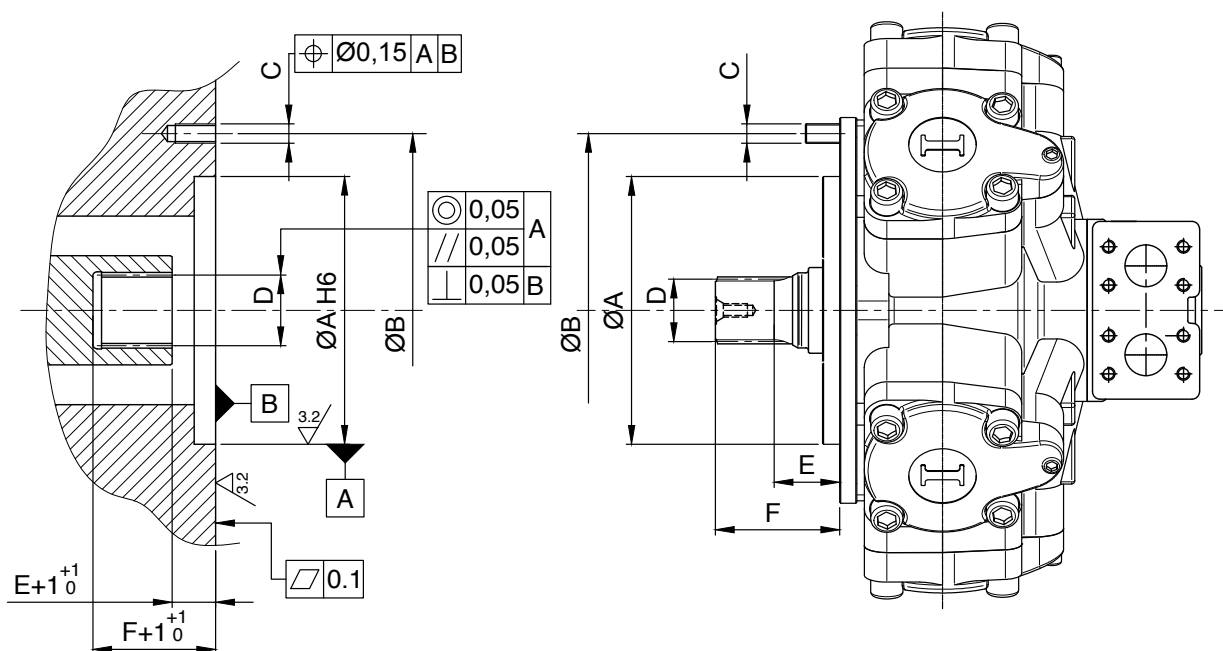

Hoses and piping must be clean and free from contamination. Use proper hoses for oil connection, both for inlet and outlet main ports, and for drain line. Refer to hoses and fitting constructors in order to correctly size and select hoses and fittings. In order to keep control on the oil compressibility keep hoses to the minimum recommended size and select pipelines most rigid as possible.

The motor can be mounted in any position (refer also to drain recommendations section). In run-away conditions you must use counterbalance valves. When the motor is installed vertically with shaft pointing upwards, consult our technical department. If the motor is connected to high inertial loads, the hydraulic system must be designed to prevent peaks of pressure and cavitation. Consider the use of relief valves, possibly directly mounted on motor distributor in case the application can generate pressure peaks at the motor ports: the relief valve should be able to discharge all the flow (or at least a good part of it) with a limited pressure increase. Italgroup can provide different valve types that can be placed directly on the motor distributor (please refer to Italgroup valves technical catalogue).

Motor case and pistons must be completely filled with oil before starting. Do not load motor to maximum working pressure instantly. During cold start-up avoid high-speed operation until the system reaches the working temperature. Connect the case drain directly to tank, and avoid excessive drain line pressure losses (the case drain pressure must not exceed 10 bar continuous pressure for R8M serie standard motors). The case drain port on the motor must be located on the highest point of the installation to ensure that the motor will always be full of oil. (See drain recommendations page for more details)

Maximum oil temperature must not exceed 70°C. Heat exchangers must be used with higher temperatures. The operating fluid viscosity must always be higher than a certain minimum value (see "fluid recommendation" section) in order to guarantee an optimal motor internal lubrication. When the working conditions cause the motor case overheating above a critical value, the motor flushing is required. Flushing consists in the introduction of fresh oil (taken from the hydraulic circuit) into the motor case. Oil must be taken from the return line to avoid internal motor damage (the continuous motor case pressure must be maximum 6 bar). Flushing is an important operation that can be very effective to improve motor lifetime with heavy duty working conditions and improve the motor mechanical efficiency.

The motor flushing, if the motor works in one direction only, can be easily performed connecting the motor return line to the lowest motor drain port. The highest motor drain port must be connected to the tank. For D75 and D90 flow distributors, the side 1/4" metallic plugs can be used for flushing circuit installation: in fact the plug (corresponding to the return line port) can be removed and the connection between motor low pressure port and motor case can be correctly realized.

MOTOR INSTALLATION AND STARTUP

If the motor axis is not horizontal and/or the motor works in bidirectional operation, please contact Italgroupt technical department, that can assist you to advice how to perform the desired operation in the best way. Just for your reference, Italgroupt can provide you flushing valves in order to perform an effective flushing circuit.

Minimum speed is very low and can reach values near to 0.5-1 rpm (depending on motor displacement). In case of low speed vibration a reasonable back pressure can eliminate or minimize the vibration and noise level (a general guideline value can be defined by 5-8 bar back pressure). For more information please contact our technical department.

R8M series motors can works in an efficient way with high back pressures (back pressure occurs for example when hydraulic motors are installed in series circuit). A general guideline for back pressure can be set limiting the inlet and outlet pressure sum to 400 bar. High back pressure values are often responsible of motor overheating, so if drain temperature reach values that bring the oil viscosity under the recommended limit (refer to fluid recommendations section), perform appropriate motor flushing and/or reduce the back pressure.

During start-up and in the period immediately after it, any hydraulic installation must be regularly and carefully checked at frequent intervals. The working pressure must be checked in order to understand that it agrees with the design values. The drain line pressure for standard motors must not overcome 10 bar continuous. If leakage occurs, check the reason, correct it and carry out new measurements. Check all lines, connections, screws, etc, and tighten if necessary. Replace contaminated fluid immediately.

The motor installation and start-up must be performed by instructed and experienced personnel only.

Please contact us freely to obtain further information.

MOTOR HANDLING AND STORAGE

Motor handling

The motor must be correctly packed during transport and correctly stored into the warehouse in order to avoid eventual damages that can make the motor functioning not adequate.

During handling operations, make sure that the motor shaft and tachometer shaft (if present) don't receive any hit, in order to avoid motor damage.

During all operations of lifting and handling, never movimentate motors by hand but use adequate tools. In order to avoid that motor can falls, creating danger for authorized working persons in the nearings, use one of following methods:

- use lifting slings of adequate capacity;
- use adequate eyebolt using the thread hole in the shaft end.

Refer to the following pictures.

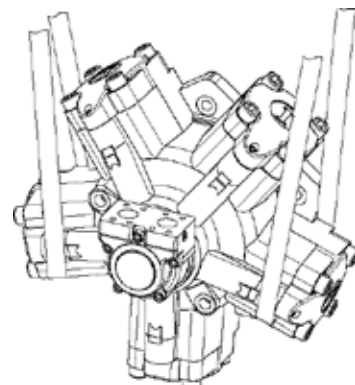
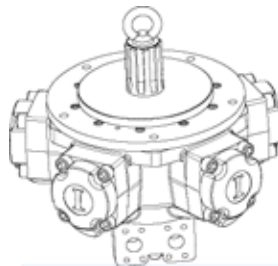

MOTOR HANDLING AND STORAGE

Storage

Storing must be carefully made using adequate storing tools (for example boxes, pallets, etc...) that can guarantee that the motor is stable and cannot move without control, in order to avoid damage problems. Make sure that the weight of the motor doesn't be substained by the motor shaft or by the tachometer shaft (if present).

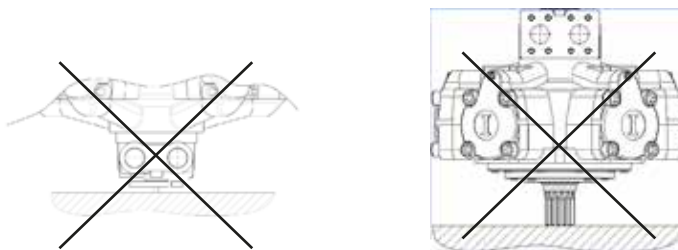

R8M series motors are supplied together with plastic plugs, that keep the hydraulic oil (that was used during final test in Italgrou testing workbench) inside the motor. A thin oil film is present on the internal motor parts, whereas the external parts are covered with antirust oil that prevents damage from oxidation and corrosion.

Therefore the motors can be safely stored into the customer warehouse without performance losses for long periods (up to 4-6 months).

The storing location must has some important characteristics:

- room temperature comprised between -15°C and $+55^{\circ}\text{C}$ without fast and/or excessives temperature excursions;
- low relative humidity;
- absence of aggressive and corrosive medias in the motor nearings.

In particular, if motor should be motionless for more than 4-6 months, it must be protected against internal rust. Proceed as follows:

- fill the motor case with hydraulic oil. After that the motor case is full of oil, close it with a screw plug;
- fill the motor also from inlet or outlet port. Turn the shaft by hand (the shaft must make about one revolution) and finally close the inlet and outlet ports.

Please note that the plastic plugs are necessary not only to keep the hydraulic oil inside the motor, but even to avoid that dirt and other fluids (like water for example) can enter into the motor and create damage during storing or during motor start-up. Therefore make sure all drain ports, supply ports and discharge ports are closed during motor handling and storing. If plugs are missing, use plastic plugs or adequate systems in order to guarantee that the motor is well protected by dirt and other fluids.

MAINTENANCE OPERATIONS

Maintenance operations All the assembly and maintenance works must be performed when the motor is stopped and not connected to any power source, in order to avoid an accidental start-up. In addition the pressure inside the motor must be set to zero (the motor must be depressurized) before to perform maintenance operations. The motor maintenance must be performed by instructed and experienced personnel only, following carefully Italgroupp advices and procedures.

R8M series motors are internally lubricated by the operating fluid, if the motors are used according to the technical data reported into the R8M catalogue, they need very limited maintenance operations. In order to achieve good performances, long bearings lifetime and safe working, the working fluid must be carefully selected in function of the operating parameters (a fundamental parameter is the ambient temperature range). In case of fire resistance fluid usage , some limitation on pressure and speed can be required. Refer to hydraulic fluid recommendations section for more information. If required please contact Italgroupp technical department for further information.

Motor parts	Material
Motor shaft, rollers, pins, screws, distributor bush, rotating distributor, distributor joint, pistons, ring for rod	Steel
Motor case, cylinders, connecting rod, motor flange, distributor body	Cast iron
Distributor disk	Bronze
Slippers	Charged PTFE, PTFE
O-Rings	Elastomer
Radial shaft seal rings	Elastomer

INSTRUCTIONS AND ADVICES

Bearings

The bearing life depends by different factors, like bearing type, motor speed, working pressure, external loads, duty cycle, fluid viscosity, oil cleanliness, type and temperature.

Lifetime is measured by L_{10} which is called “theoretic lifetime”. It represents the number of cycles that 90% of identical bearings can effort at the same load without showing wear and tear.

Please refer to bearing lifetime diagrams reported in the following pages to obtain the theoretical bearing lifetime. **The lifetimes diagrams shown the L_{50} , median or average lifetime, that can be considered as 5 times L_{10} .**

Please note that the theoretical lifetime can be different from the real lifetime, especially in case of heavy duty applications with continuous work cycle.

Please contact Italgrou S.r.l. for more information.

Motor creep speed

The hydraulic motor is able to hold the load acting as a brake (if proper valves or circuit are considered and installed), but a certain creep speed is always present: this is typical of all brands hydraulic motors.

The motor creep speed depends by many factors, like operating conditions (motor displacement and type, pressure load on the shaft, oil viscosity, type and temperature)

If creep speed is higher than desired value a negative brake can be considered: Italgrou can supply negative brakes that can be fitted to the hydraulic motor.

Please contact Italgrou S.r.l. for more information.

SPECIAL FEATURES

Special features

Marine painting

If needed, special painting or primers are available in order to guarantee optimal protection against normal corrosion and marine environment corrosion. The ordering code is MP. Please contact Italgroup S.r.l. for more information.

Speedy-sleeve

A special inox sleeve is available upon request. In case the motor is used in aggressive medias or environments, this can be very useful in order to protect the motor shaft surface located in proximity of the motor shaft seal. This improves the shaft and seal endurance respect to wear and corrosion. The ordering code is SPSL. Please contact Italgroup S.r.l. for more information.

High pressure shaft seal

Standard R8M motors are supplied with high pressure shaft seals, the continuous drain pressure must be maximum 6 bar, whereas the peak drain pressure must be maximum 10 bar. In case the drain line can or must has a higher pressure, special shaft seals are available upon request. The ordering code is HPS. The drain pressure with HPS shaft seal can reach 20-25 bar continuous pressure and 30 bar peak pressure. The HPS shaft seal is bi-directional also, so it can be used for example in underwater applications. Please contact Italgroup S.r.l. for more information.

Counterclockwise rotation

Standard R8M motors are supplied with clockwise distributor timing. Please refer to the installation drawings of each section for more information. With ordering code CCW the motor is supplied with counterclockwise rotation timing. Contact Italgroup for more information.

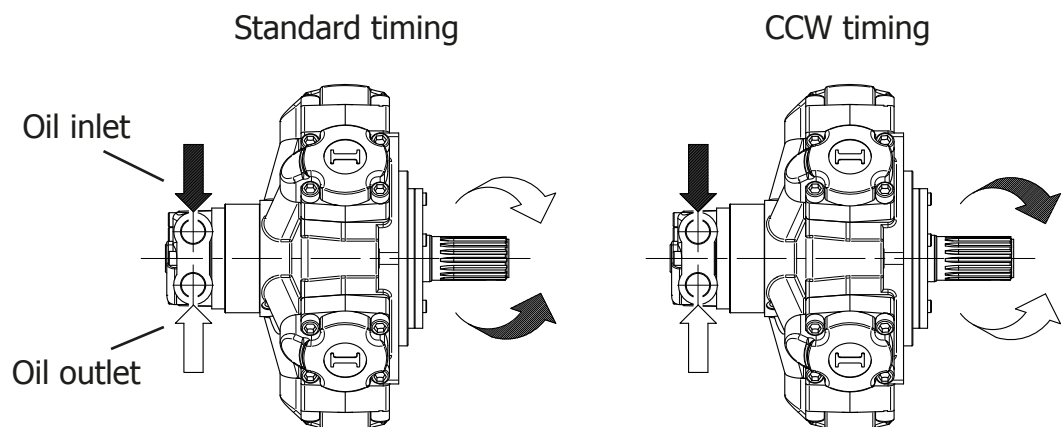

TROUBLESHOOTING

Problem	Possible cause	Solution
Excessive noises	Cavitation	Adopt an anti-cavitation system
	Mechanical vibrations	Check and fix damaged components
	Irregular pressure or flow	Check other components (pump, valves, accumulators) and check drain flow
	Air bubbles in the circuit	Bleed circuit
Unit overheating	Overflow	Check max allowed flow
	Overpressure	Check relief valve pressure setting
	Oil viscosity too low	Choose the appropriate oil according to the temperature
	Undersized cooling system	Improve cooling system
	Working without oil in the case	Overhaul the unit, fill with oil before start-up
Anomalous drainage flow	Worn motor internal components	Overhaul the motor
	Motor internal seals worn	Overhaul the motor
	Excessive pressure in the motor case	Check drain port size, pressure and flow, check piping connections
Insufficient torque	Pressure relief valve set incorrectly	Check relief valve pressure setting
	Undersized motor displacement	Replace with bigger displ. motor
	Pump not able to reach the design pressure	Check pump integrity
Insufficient speed	Oversized motor displacement	Replace with smaller displ. motor
	Pump not able to reach the design flow	Check pump integrity
	Undersized pump	Improve pump output flow
	Excessive drain flow	Overhaul the motor
Output shaft cannot rotate	Seized motor flow distributor	Overhaul the flow distributor
	Motor internal seizure	Overhaul the motor
	Motor internal seals worn	Check drain flow, overhaul the motor
	Air in the circuit	Bleed the circuit

Problem	Possible cause	Solution
Oil leakage	Worn seals	Replace seals
	Excessive pressure in the motor case	Check drain port size, pressure and flow, check piping connections
	Burst motor shaft seal	Check drain port size, pressure and flow, check piping connections
Incorrect sense of rotation	Pipes incorrectly connected	Check pipe connections
	Incorrect rotating distributor timing	Change rotating distributor timing

UNITS CONVERSION

LENGHT 1 m = 39,3701 in
= 3,2808 ft
= 1,0936 yd
= 1000 mm

1 in = 0,0833 ft
= 25,4 mm

1 ft = 0,3048 m
= 0,3333 yd
= 12 in

1 yd = 0,9144 m
= 3 ft

= 36 in

1 km = 1000 m
= 1093,6 yd
= 0,6214 mile

1 mile = 1,609 km
= 1760 yd

SPEED 1 m/s = 3,6 km/h
= 2,237 mph
= 3,2808 ft/s

1 km/h = 0,2778 m/s
= 0,6214 mph
= 0,9113 ft/s

1 mph = 1,609 km/h
= 0,447 m/s
= 1,467 ft/s

1 ft/s = 0,3048 m/s
= 1,0973 km/h
= 0,6818 mph

MASS 1 kg = 2,2046 lb

FORCE 1 N = 0,102 kgf
= 0,2248 lbf

1 kgf = 2,205 lbf
= 9,806 N

1 lbf = 0,4536 kgf
= 4,448 N

PRESSURE 1 bar = 14,223 psi
= 0,99 atm

= 1,02 ata

= 100000 Pa

= 100 kPa

= 0,1 MPa

1 psi = 0,0703 bar

FLOW 1 l/min = 0,264 gpm
= 1000 cc/Rev

1 gpm = 3,785 l/min
= 3785 cc/min

1 m³/s = 60000 l/min
= 15852 gpm

POWER 1 kW = 1,341 HP
= 1,3596 CV

1 HP = 0,7457 kW
= 1,0139 CV

VOLUME 1 m³ = 1000 l

1 l = 61,023 in³
= 0,264 galUS

1 in³ = 0,01639 l

= 16,39 cm³

= 0,004326 galUS

= 0,004326 galUS

1 galUS = 3,7879 l

= 231,15 in³

TORQUE 1 Nm = 0,102 kgm

= 0,7376 lbf ft

1 kgm = 9,806 Nm

= 7,2325 lbf ft

1 lbf ft = 0,1383 kgm

= 1,3558 Nm

R8M H1

R8M 80-100-150-175-195 H1	Pag. 28 - 29
R8M 200-250-300 H1	Pag. 30 - 31
R8M H1/GM05	Pag. 32 - 33
R8M H1/BH	Pag. 34 - 35
R8M H1/GM1	Pag. 36 - 37
R8M 200-250-300/PH H1	Pag. 38 - 39
R8M H1 - PERFORMANCE CURVES	Pag. 40 - 44
R8M H1 - ORDERING CODE	Pag. 45

R8M 80-100-150-175-195 H1

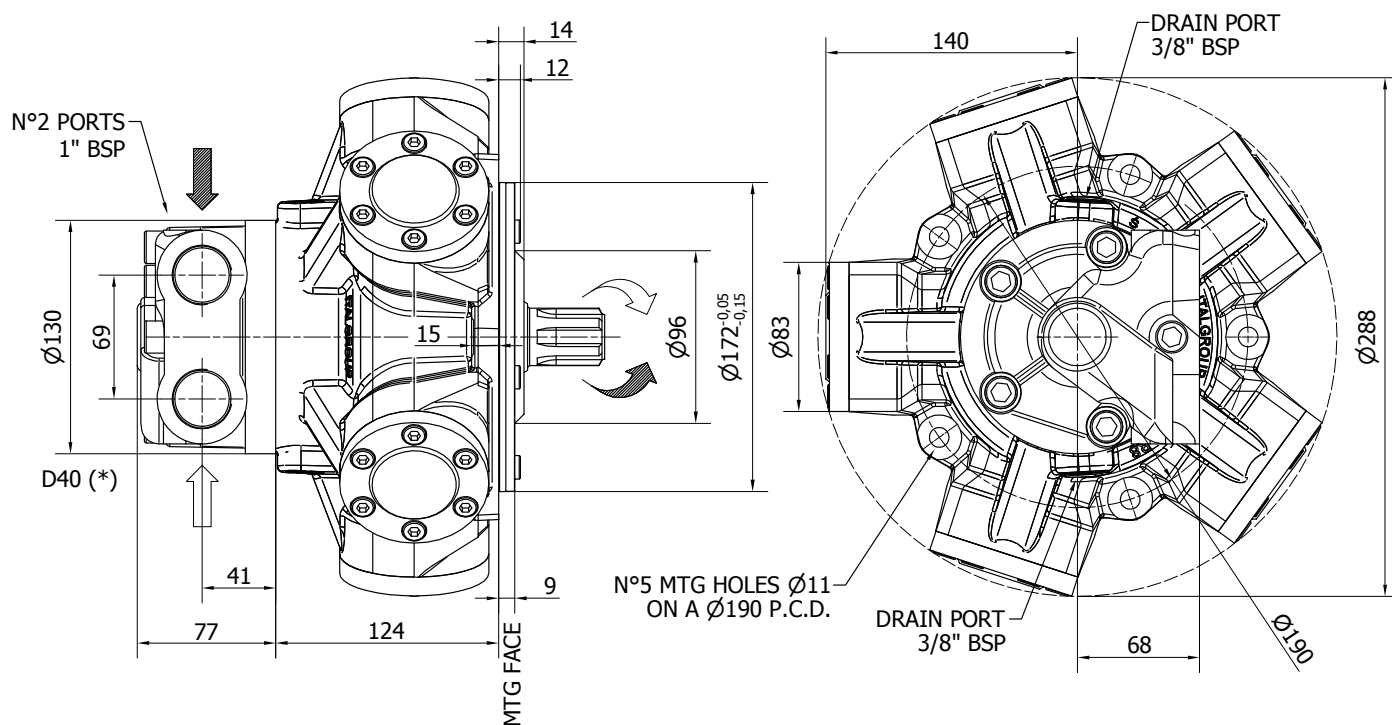

TECHNICAL DATA

		80	100	150	175	195
DISPLACEMENT	[cc]	80	100	157	176	195
SPECIFIC TORQUE	[Nm/bar]	1.3	1.6	2.5	2.8	3.1
MAX. CONT. PRESSURE	[bar]	270	270	270	270	270
HYDROSTATIC TEST PRESSURE	[bar]	420	420	420	420	420
MAX. CONT. SPEED	[rpm]	950	950	950	800	800
PEAK SPEED (***)	[rpm]	1050	1050	1050	900	900
MAX. CONT. POWER (****)	[kW]	28	28	28	28	28
MAX. POWER	[kW]	41	41	41	41	41
MAX. CASE PRESSURE	[bar]	6	6	6	6	6
DRY WEIGHT	[kg]	26	26	26	26	26
TEMPERATURE RANGE (**)	[°C]	-30÷70	-30÷70	-30÷70	-30÷70	-30÷70

- (*) The standard distributor (D40) is shown. Please refer to distributors section (pag. 178-179) for different distributor interfaces.

- (**) Please refer to the hydraulic fluid recommendations (pag. 10-11).

- (***) Do not exceed maximum power.

- (****) For motor operation with a continuous duty cycle at maximum continuous power the flushing is usually required (see pag. 13). For more information please contact our technical department.

SHAFTS

A0

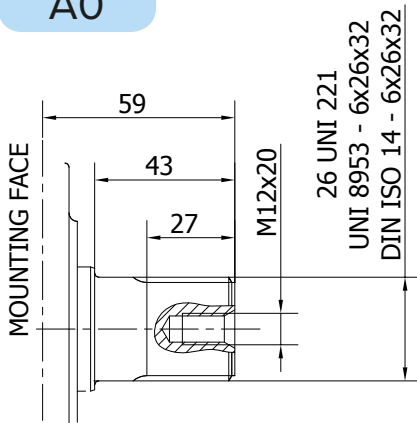

Available spline billet: SB1

A1

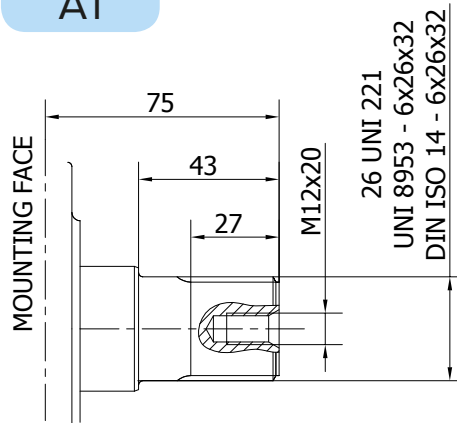

Available spline billet: SB1

NOT AVAILABLE
FOR 80 cc

A11

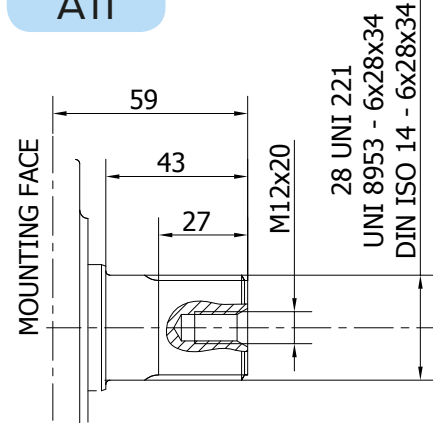

Available spline billet: SB14

NOT AVAILABLE
FOR 80 cc

A14

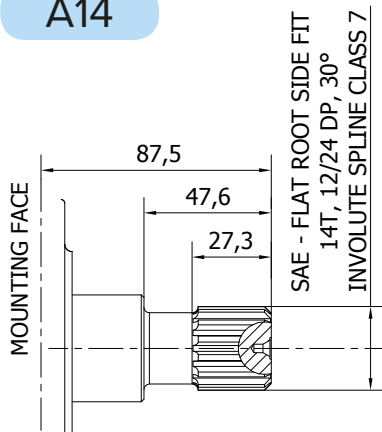

A2

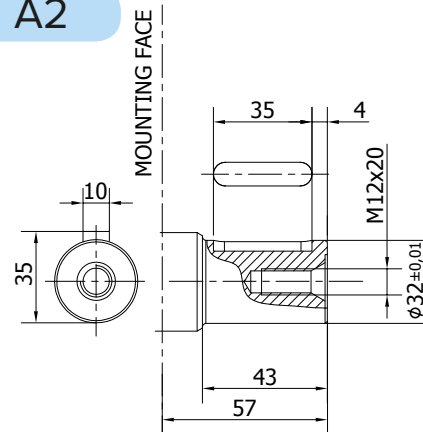

NOT AVAILABLE
FOR 80 cc

SHAFTS

A0

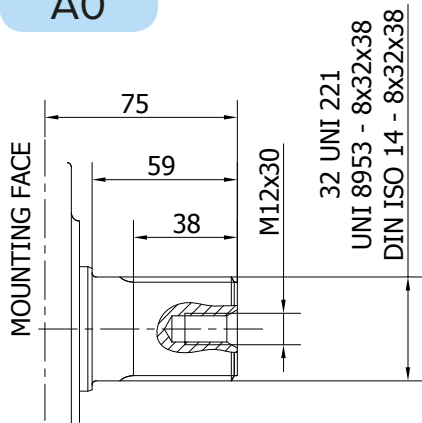

Available spline billet: SB2

A12

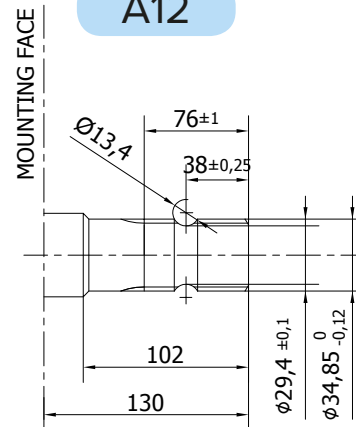

A2

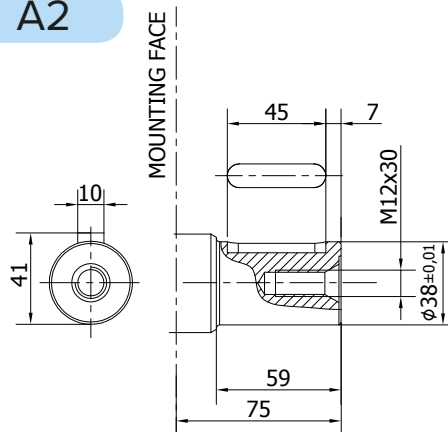

R8M H1/GM05

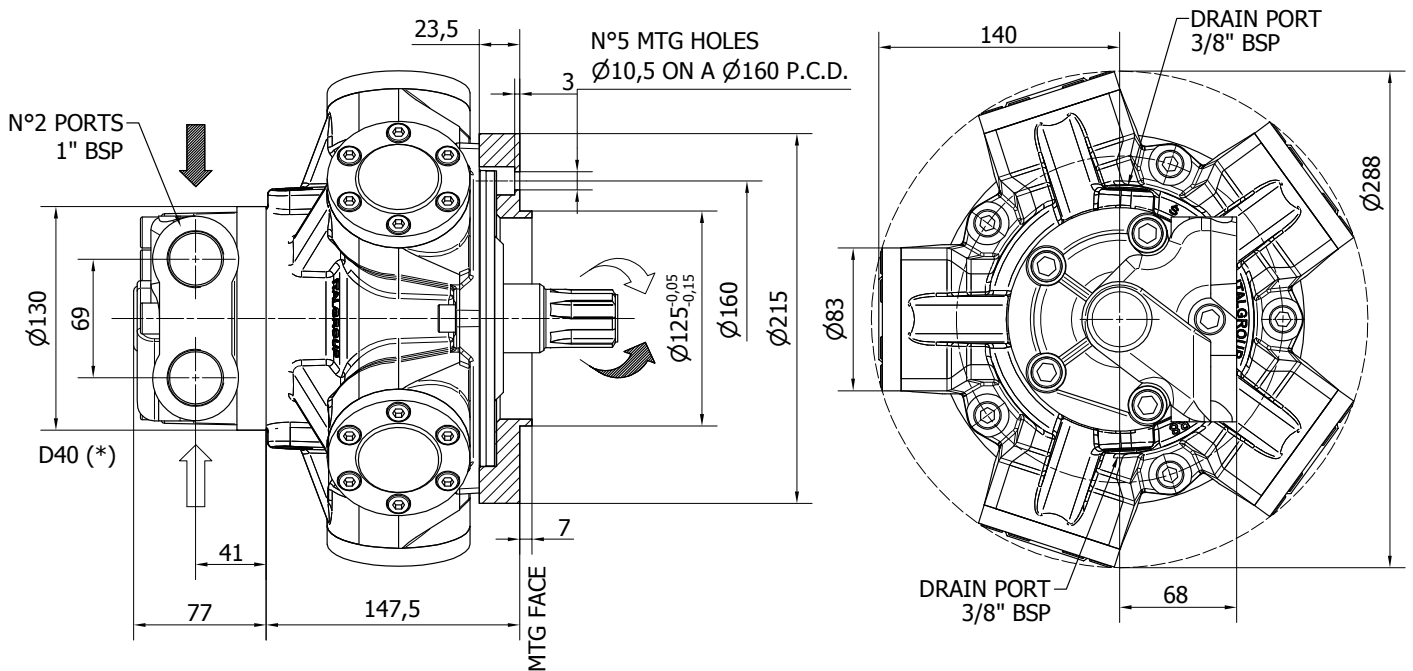

TECHNICAL DATA

		100	150	175	195	250
DISPLACEMENT	[cc]	100	157	176	195	257
SPECIFIC TORQUE	[Nm/bar]	1.6	2.5	2.8	3.1	4.1
MAX. CONT. PRESSURE	[bar]	270	270	270	270	250
HYDROSTATIC TEST PRESSURE	[bar]	420	420	420	420	420
MAX. CONT. SPEED	[rpm]	950	950	800	800	750
PEAK SPEED (**)	[rpm]	1050	1050	900	900	850
MAX. CONT. POWER (***)	[kW]	28	28	28	28	28
MAX. POWER	[kW]	41	41	41	41	41
MAX. CASE PRESSURE	[bar]	6	6	6	6	6
DRY WEIGHT	[kg]	26	26	26	26	26
TEMPERATURE RANGE (**)	[°C]	-30÷70	-30÷70	-30÷70	-30÷70	-30÷70

- (*) The standard distributor (D40) is shown. Please refer to distributors section (pag. 178-179) for different distributor interfaces.

- (**) Please refer to the hydraulic fluid recommendations (pag. 10-11).

- (***) Do not exceed maximum power.

- (****) For motor operation with a continuous duty cycle at maximum continuous power the flushing is usually required (see pag. 13). For more information please contact our technical department.

SHAFTS

A0

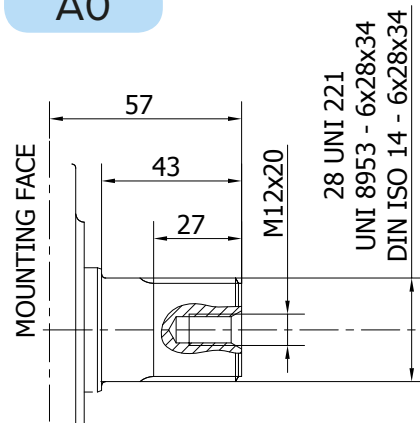

Available spline billet: SB14

R8M H1/BH

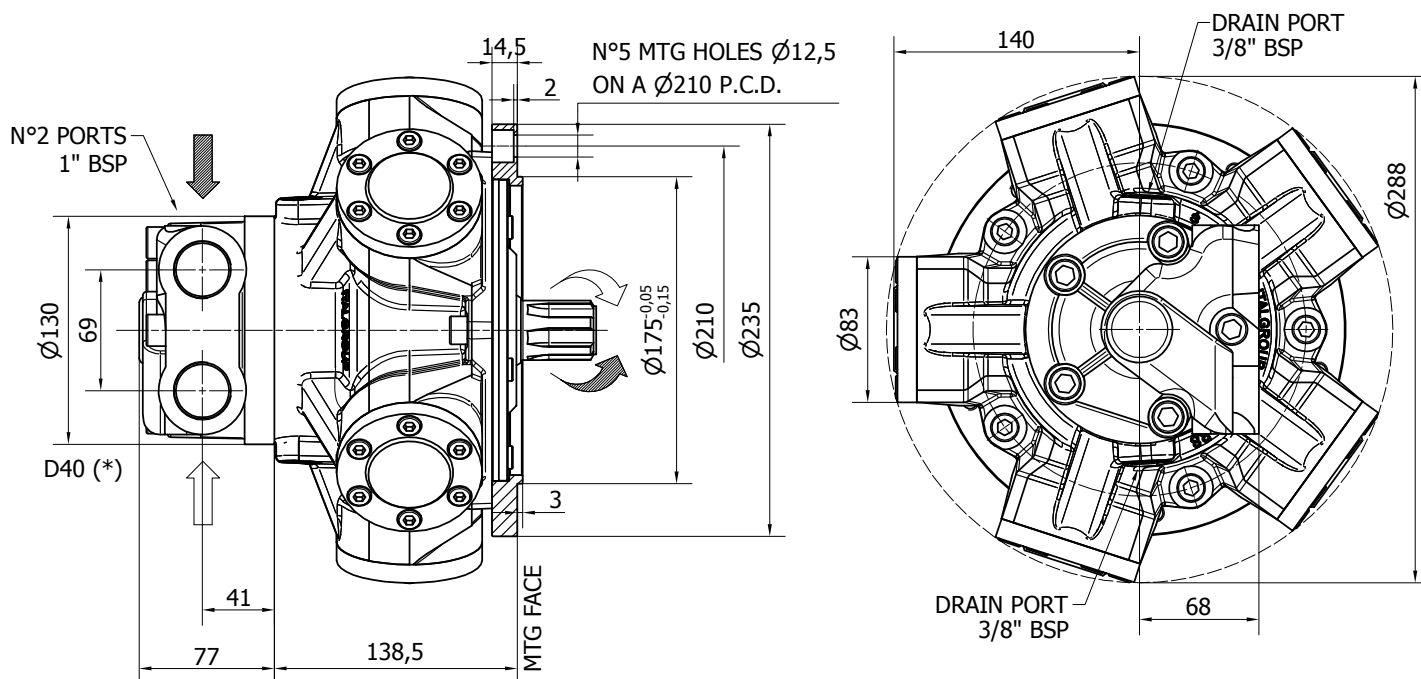

TECHNICAL DATA

		100	150	175	195	250	300
DISPLACEMENT	[cc]	100	157	176	195	257	307
SPECIFIC TORQUE	[Nm/bar]	1.6	2.5	2.8	3.1	4.1	4.9
MAX. CONT. PRESSURE	[bar]	270	270	270	270	250	250
HYDROSTATIC TEST PRESSURE	[bar]	420	420	420	420	420	420
MAX. CONT. SPEED	[rpm]	950	950	800	800	750	750
PEAK SPEED (***)	[rpm]	1050	1050	900	900	850	850
MAX. CONT. POWER (****)	[kW]	28	28	28	28	28	28
MAX. POWER	[kW]	41	41	41	41	41	41
MAX. CASE PRESSURE	[bar]	6	6	6	6	6	6
DRY WEIGHT	[kg]	26	26	26	26	26	26
TEMPERATURE RANGE (**)	[°C]	-30÷70	-30÷70	-30÷70	-30÷70	-30÷70	-30÷70

- (*) The standard distributor (D40) is shown. Please refer to distributors section (pag. 178-179) for different distributor interfaces.

- (**) Please refer to the hydraulic fluid recommendations (pag. 10-11).

- (***) Do not exceed maximum power.

- (****) For motor operation with a continuous duty cycle at maximum continuous power the flushing is usually required (see pag. 13). For more information please contact our technical department.

SHAFTS

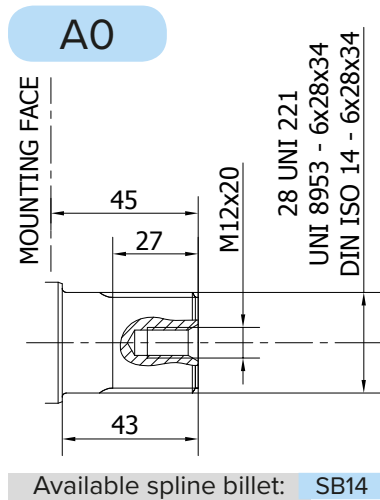

R8M H1/GM1

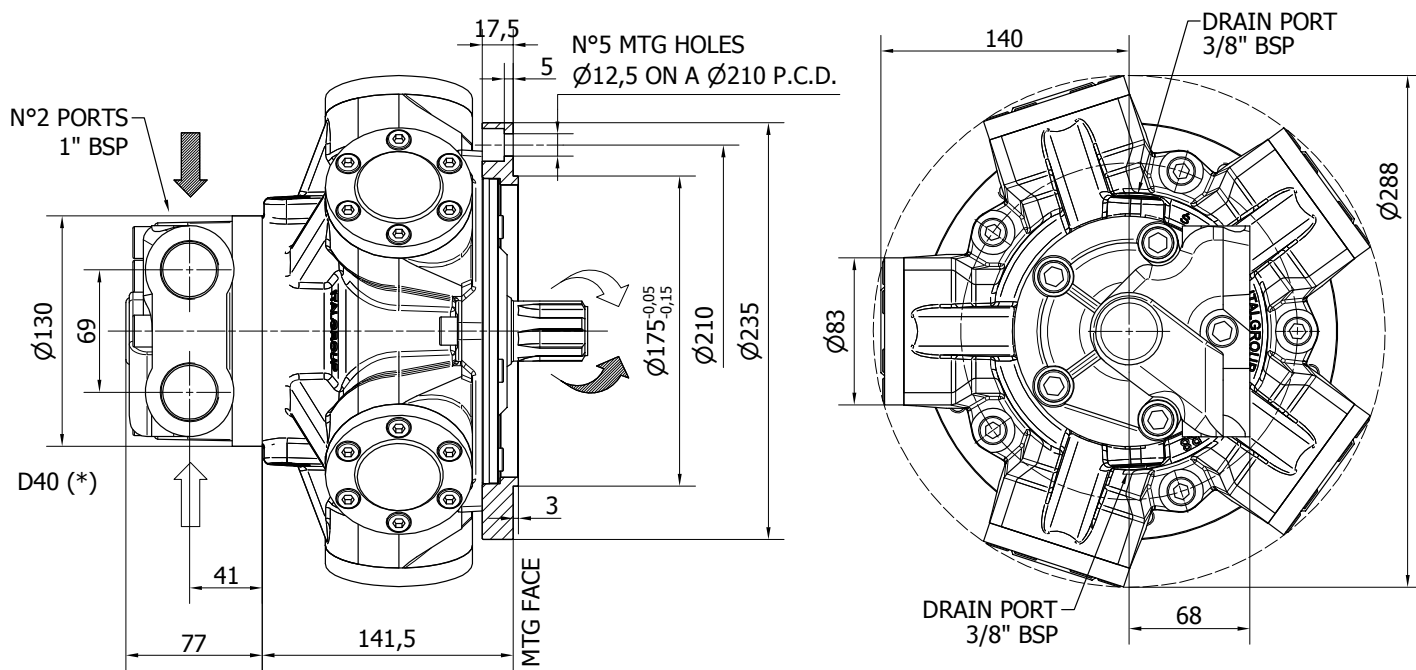

TECHNICAL DATA

		100	150	175	195	250	300
DISPLACEMENT	[cc]	100	157	176	195	257	307
SPECIFIC TORQUE	[Nm/bar]	1.6	2.5	2.8	3.1	4.1	4.9
MAX. CONT. PRESSURE	[bar]	270	270	270	270	250	250
HYDROSTATIC TEST PRESSURE	[bar]	420	420	420	420	420	420
MAX. CONT. SPEED	[rpm]	950	950	800	800	750	750
PEAK SPEED (***)	[rpm]	1050	1050	900	900	850	850
MAX. CONT. POWER (****)	[kW]	28	28	28	28	28	28
MAX. POWER	[kW]	41	41	41	41	41	41
MAX. CASE PRESSURE	[bar]	6	6	6	6	6	6
DRY WEIGHT	[kg]	26	26	26	26	26	26
TEMPERATURE RANGE (**)	[°C]	-30÷70	-30÷70	-30÷70	-30÷70	-30÷70	-30÷70

- (*) The standard distributor (D40) is shown. Please refer to distributors section (pag. 178-179) for different distributor interfaces.

- (**) Please refer to the hydraulic fluid recommendations (pag. 10-11).

- (***) Do not exceed maximum power.

- (****) For motor operation with a continuous duty cycle at maximum continuous power the flushing is usually required (see pag. 13). For more information please contact our technical department.

SHAFTS

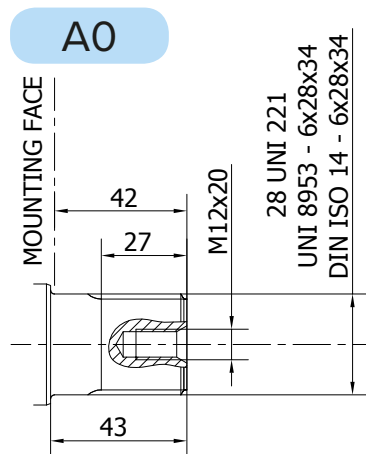

Available spline billet: SB14

SHAFTS

A0

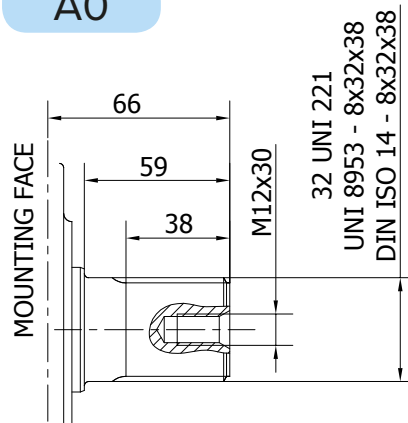

Available spline billet: SB2

R8M H1 - PERFORMANCE CURVES

R8M 80 H1

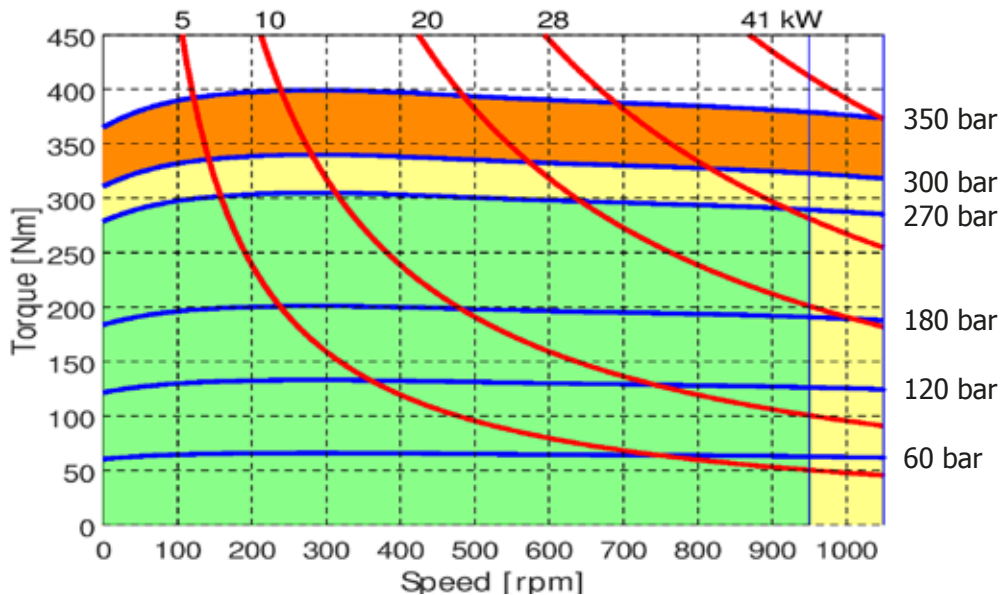

R8M 100 H1

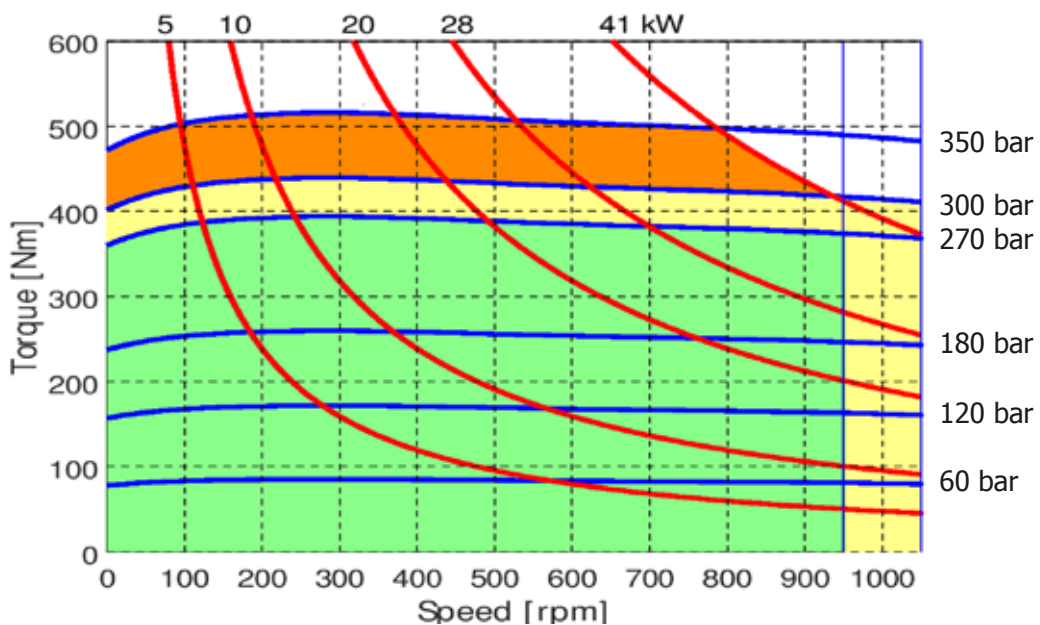

- Continuous operation
- Continuous operation with flushing or intermittent operation (see below for intermittent operation)
- Intermittent operation: permitted for a 15% of duty cycle, for 3 minutes maximum period
- Peak operation: permitted for very short periods (3-5 seconds every 10-15 minutes)

The above diagrams are referring to the hydraulic motor working with a fluid in ideal conditions (viscosity at 40 cSt). In case the working temperature increases and viscosity reach values under the recommended values (see hydraulic fluid recommendations) flushing must be performed or ISO oil grade must be changed. The working temperature must not overcome 70 °C.

R8M 150 H1

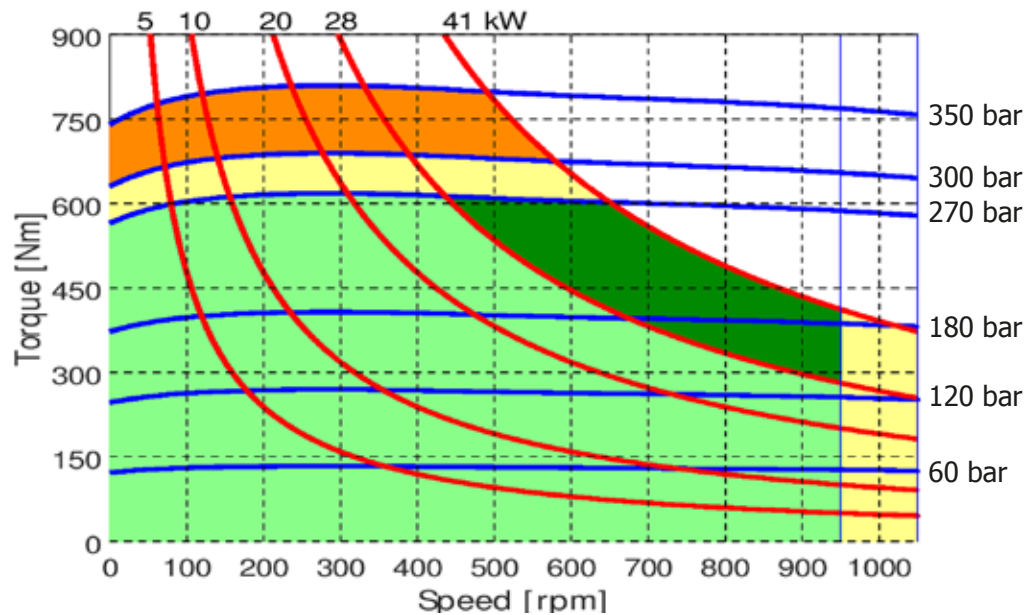

R8M 175 H1

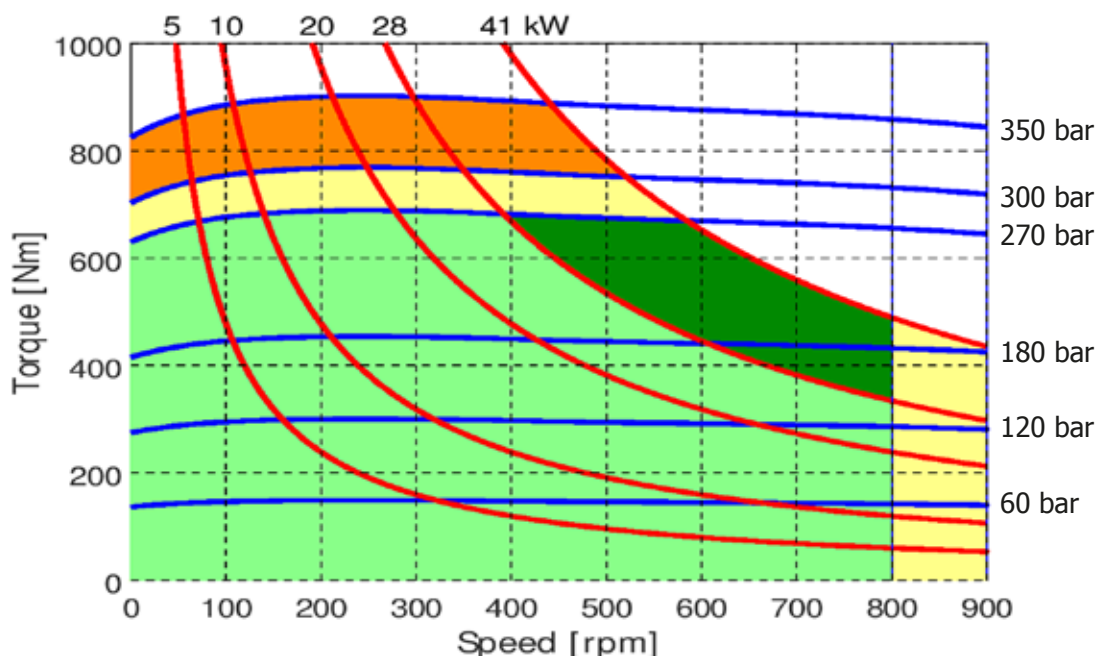

- Continuous operation
- Continuous operation with flushing or intermittent operation (see below for intermittent operation)
- Intermittent operation: permitted for a 15% of duty cycle, for 3 minutes maximum period
- Peak operation: permitted for very short periods (3-5 seconds every 10-15 minutes)

The above diagrams are referring to the hydraulic motor working with a fluid in ideal conditions (viscosity at 40 cSt). In case the working temperature increases and viscosity reach values under the recommended values (see hydraulic fluid recommendations) flushing must be performed or ISO oil grade must be changed. The working temperature must not overcome 70 °C.

R8M H1 - PERFORMANCE CURVES

R8M 195 H1

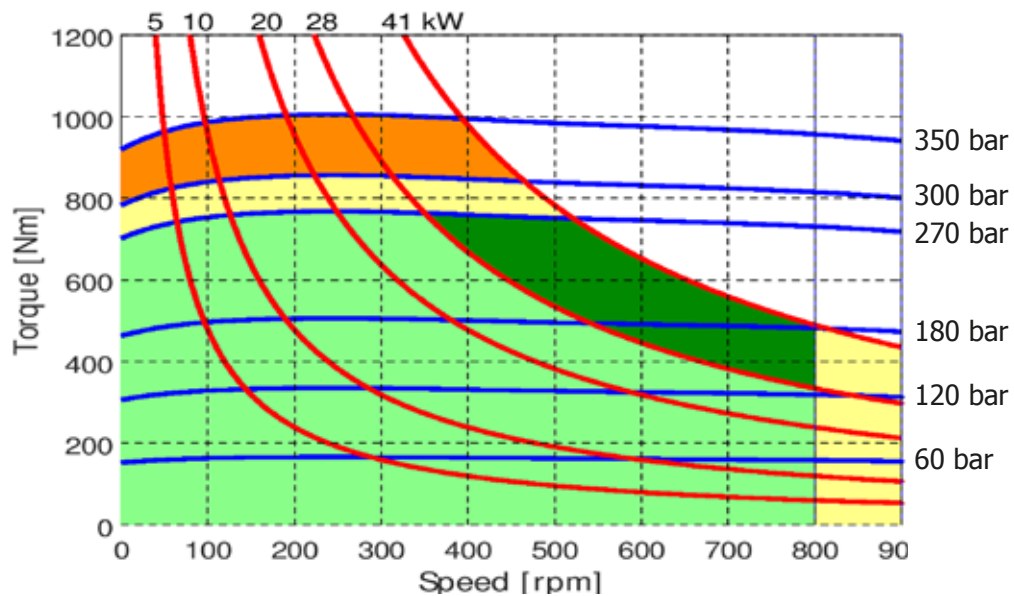

R8M 200 H1

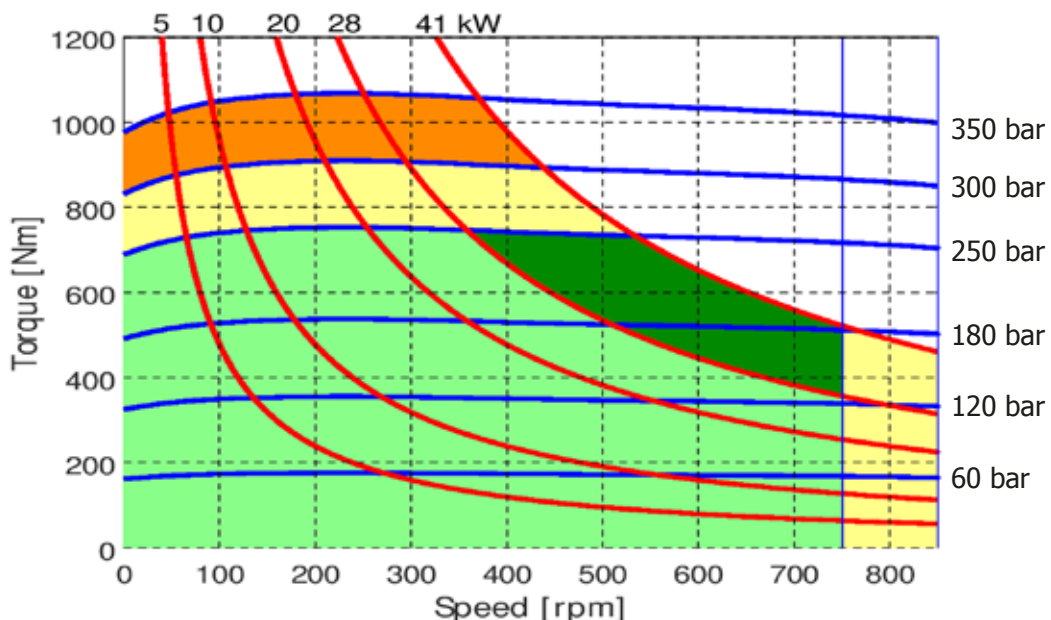

- Continuous operation
- Continuous operation with flushing or intermittent operation (see below for intermittent operation)
- Intermittent operation: permitted for a 15% of duty cycle, for 3 minutes maximum period
- Peak operation: permitted for very short periods (3-5 seconds every 10-15 minutes)

The above diagrams are referring to the hydraulic motor working with a fluid in ideal conditions (viscosity at 40 cSt). In case the working temperature increases and viscosity reach values under the recommended values (see hydraulic fluid recommendations) flushing must be performed or ISO oil grade must be changed. The working temperature must not overcome 70 °C.

R8M 250 H1

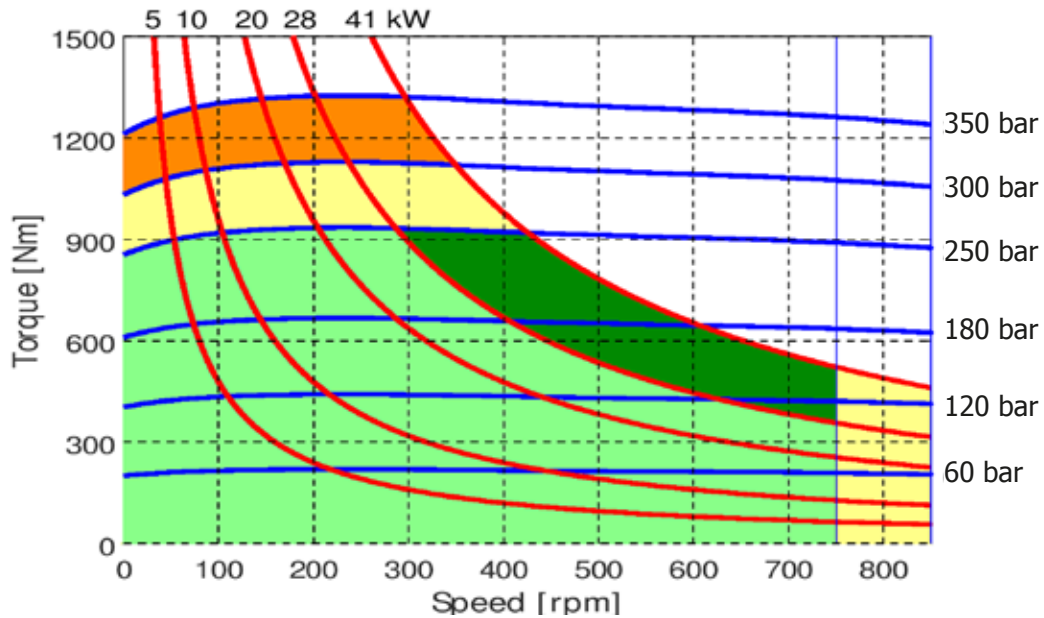

R8M 300 H1

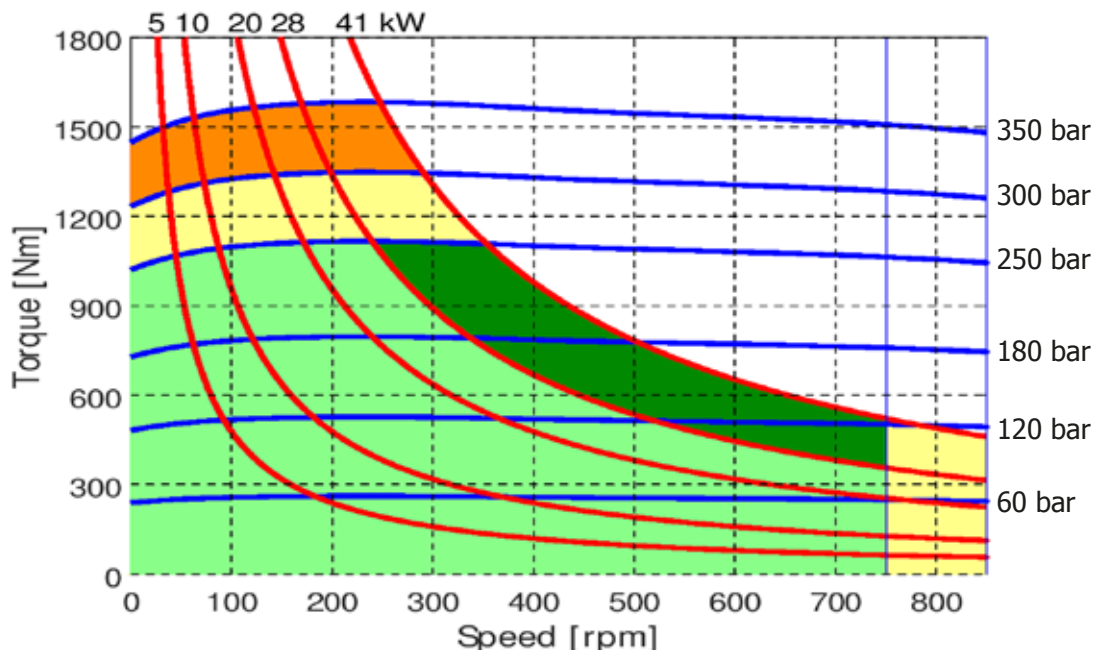

- Continuous operation
- Continuous operation with flushing or intermittent operation (see below for intermittent operation)
- Intermittent operation: permitted for a 15% of duty cycle, for 3 minutes maximum period
- Peak operation: permitted for very short periods (3-5 seconds every 10-15 minutes)

The above diagrams are referring to the hydraulic motor working with a fluid in ideal conditions (viscosity at 40 cSt). In case the working temperature increases and viscosity reach values under the recommended values (see hydraulic fluid recommendations) flushing must be performed or ISO oil grade must be changed. The working temperature must not overcome 70 °C.

R8M H1 - PERFORMANCE CURVES

BEARING LIFE

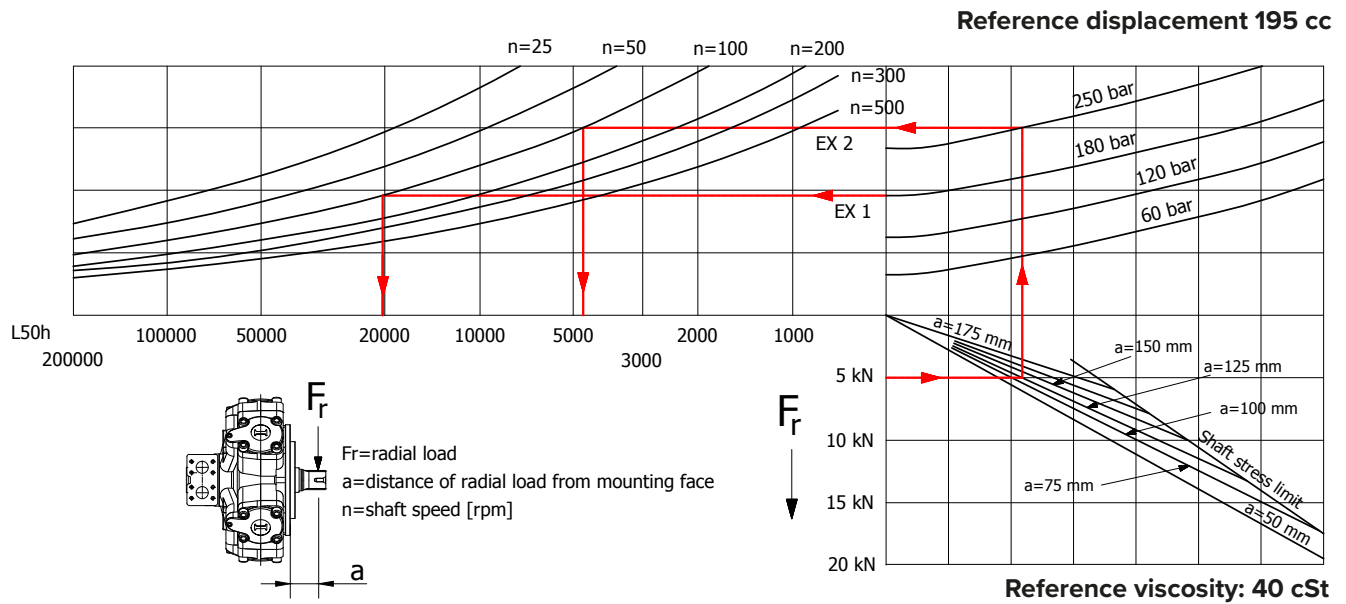

Example:

We suppose (EX1): $p=180$ [bar], $n=100$ [rpm]; we obtain an average lifetime of 20000 [h].

If we suppose (EX2): $F_r=5$ [kN], $a=125$ [mm], $p=250$ [bar] and $n=100$ [rpm], we obtain an average lifetime of 4500 [h].

The above data are referring to the R8M H1 series motors, displacement 195 cc.

R8M H1 - ORDERING CODE

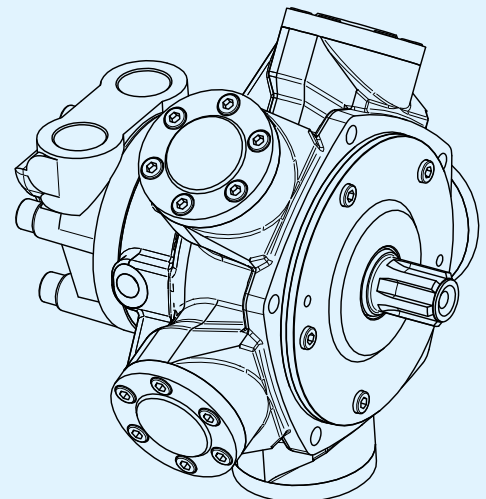
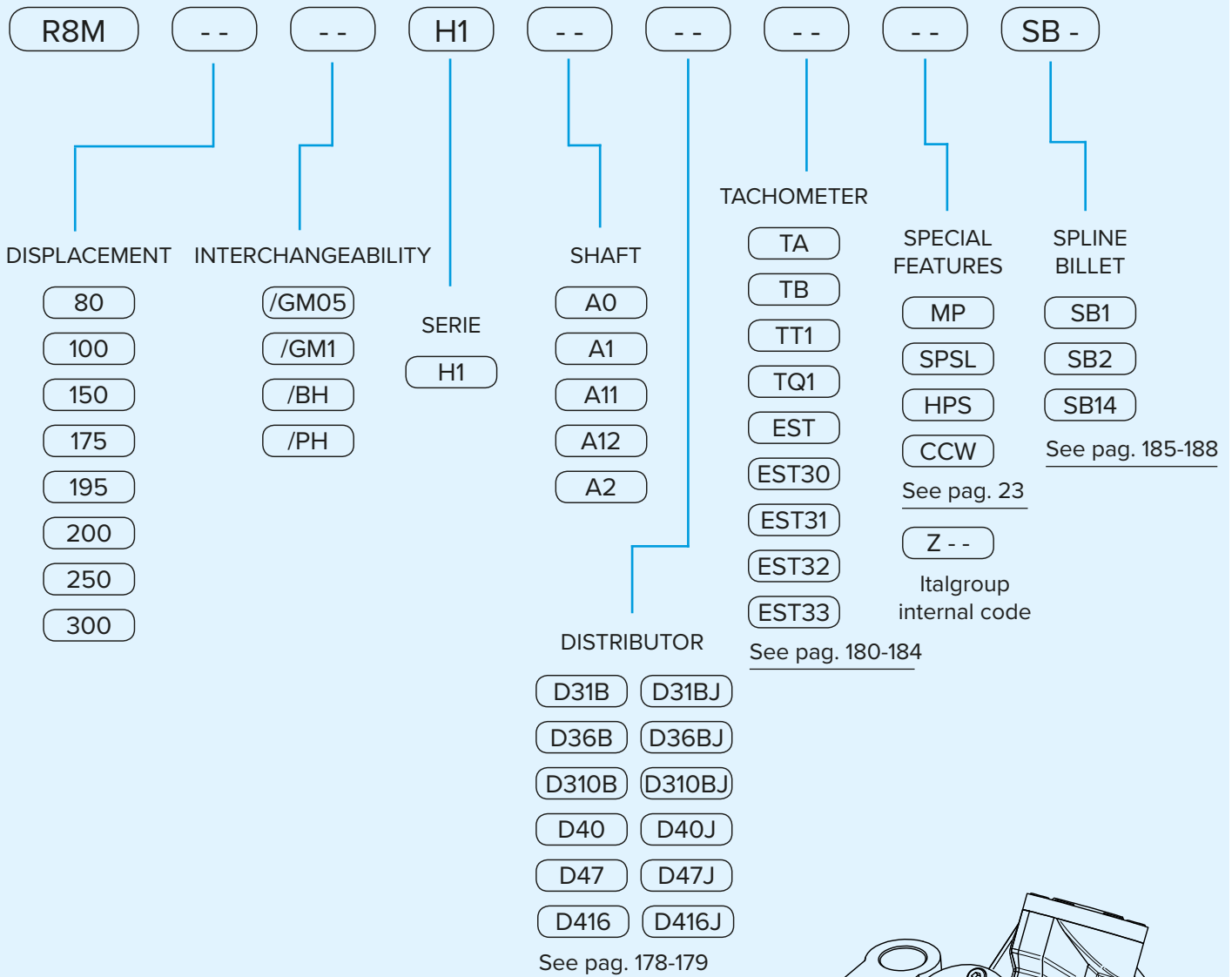

EXAMPLES:

R8M 100 H1 A0 D40
 R8M 195/GM1 H1 A0 D40J SB14
 R8M 200/PH H1 A0 D31B

R8M H2

R8M 200-250-300-350 H2	Pag. 48 - 49
R8M 400-500-600 H2	Pag. 50 - 51
R8M 160-190-250/C190 H2	Pag. 52 - 53
R8M 250-300-350-400/C300 H2	Pag. 54 - 55
R8M 200/B10 H2	Pag. 56 - 57
R8M H2/PH	Pag. 58 - 59
R8M H2/GM2	Pag. 60 - 61
R8M H2/S	Pag. 62 - 63
R8M H2 - PERFORMANCE CURVES	Pag. 64 - 69
R8M H2 - ORDERING CODE	Pag. 70

R8M 200-250-300-350 H2

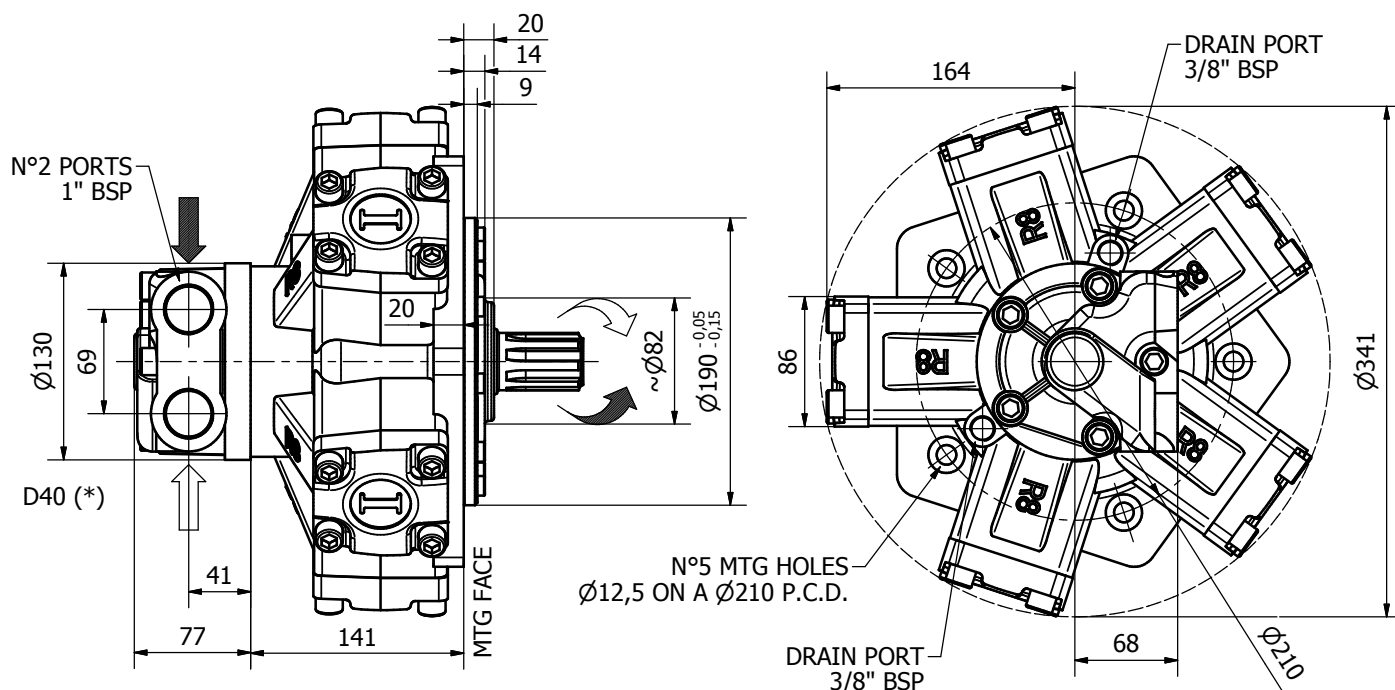

TECHNICAL DATA

		200	250	300	350
DISPLACEMENT	[cc]	198	253	314	362
SPECIFIC TORQUE	[Nm/bar]	3.2	4.0	5.0	5.8
MAX. CONT. PRESSURE	[bar]	270	270	270	270
HYDROSTATIC TEST PRESSURE	[bar]	420	420	420	420
MAX. CONT. SPEED	[rpm]	800	750	750	650
PEAK SPEED (***)	[rpm]	900	850	850	750
MAX. CONT. POWER (****)	[kW]	35	35	35	35
MAX. POWER	[kW]	50	50	50	50
MAX. CASE PRESSURE	[bar]	6	6	6	6
DRY WEIGHT	[kg]	42	42	42	42
TEMPERATURE RANGE (**)	[°C]	-30÷70	-30÷70	-30÷70	-30÷70

- (*) The standard distributor (D40) is shown. Please refer to distributors section (pag. 178-179) for different distributor interfaces.

- (**) Please refer to the hydraulic fluid recommendations (pag. 10-11).

- (***) Do not exceed maximum power.

- (****) For motor operation with a continuous duty cycle at maximum continuous power the flushing is usually required (see pag. 13). For more information please contact our technical department.

SHAFTS

A0

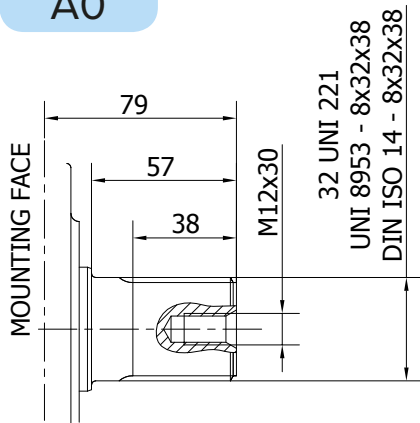

Available spline billet: SB2

A2

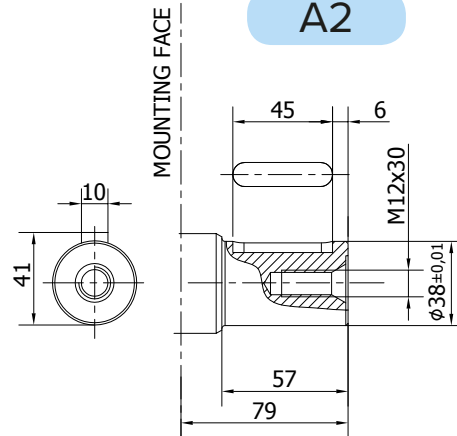

A3

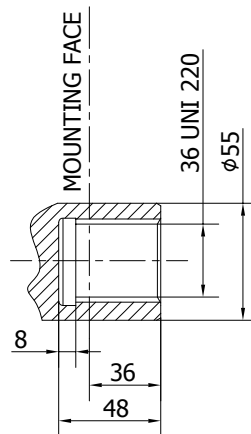

Available spline bar: B8078

R8M 400-500-600 H2

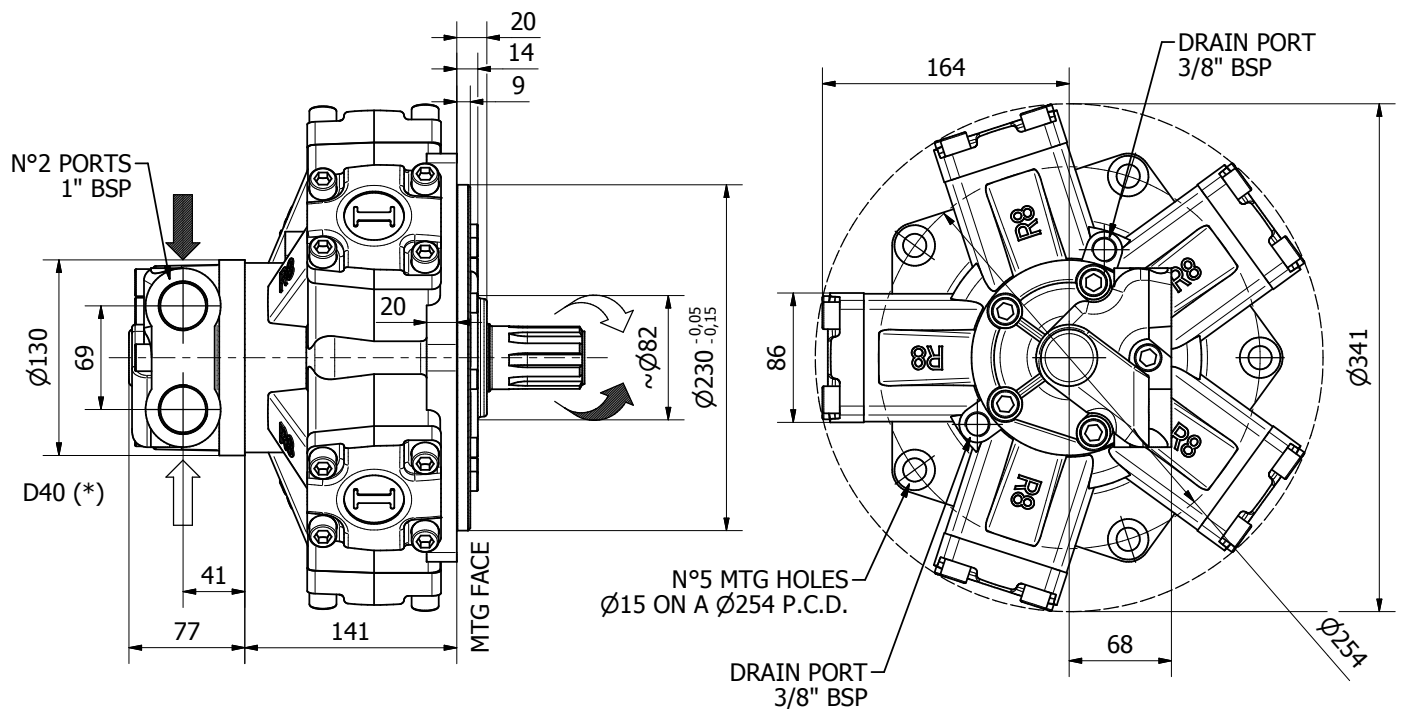

TECHNICAL DATA

		400	500	600
DISPLACEMENT	[cc]	424	492	584
SPECIFIC TORQUE	[Nm/bar]	6.7	7.8	9.3
MAX. CONT. PRESSURE	[bar]	270	260	250
HYDROSTATIC TEST PRESSURE	[bar]	420	420	420
MAX. CONT. SPEED	[rpm]	600	500	500
PEAK SPEED (***)	[rpm]	700	600	600
MAX. CONT. POWER (****)	[kW]	35	35	35
MAX. POWER	[kW]	50	50	50
MAX. CASE PRESSURE	[bar]	6	6	6
DRY WEIGHT	[kg]	42	42	42
TEMPERATURE RANGE (**)	[°C]	-30÷70	-30÷70	-30÷70

- (*) The standard distributor (D40) is shown. Please refer to distributors section (pag. 178-179) for different distributor interfaces.

- (**) Please refer to the hydraulic fluid recommendations (pag. 10-11).

- (***) Do not exceed maximum power.

- (****) For motor operation with a continuous duty cycle at maximum continuous power the flushing is usually required (see pag. 13). For more information please contact our technical department.

SHAFTS

A0

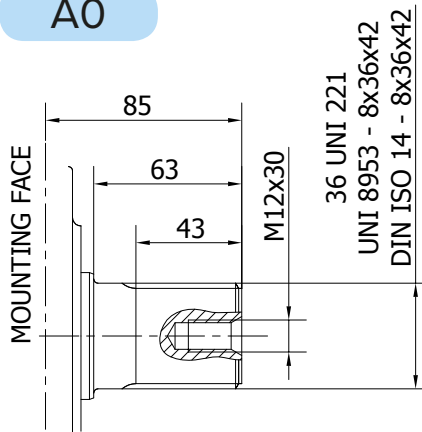

Available spline billet: SB3

A2

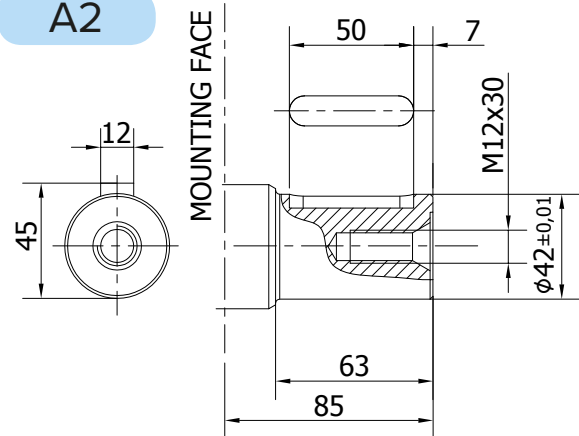

A3

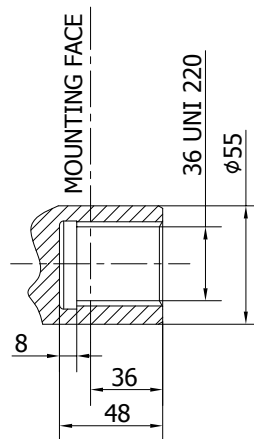

Available spline bar: B8078

R8M 160-190-250/C190 H2

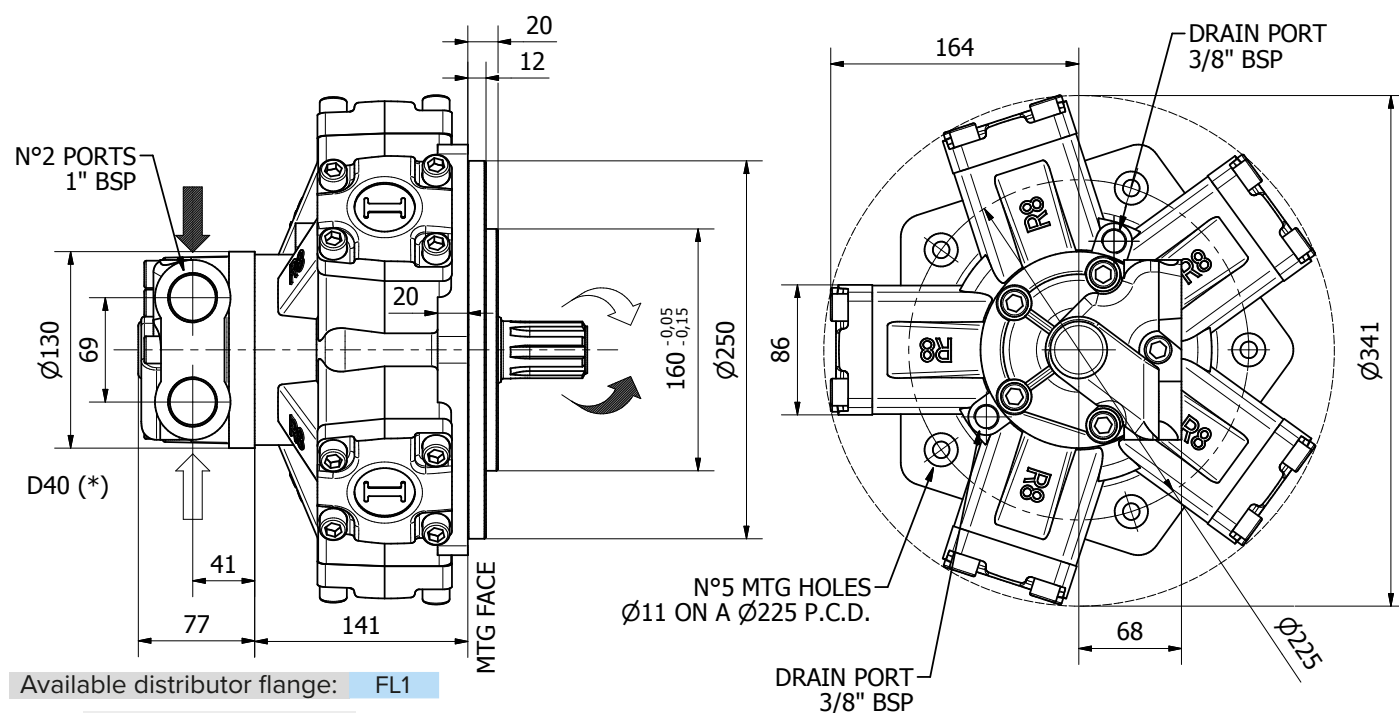

TECHNICAL DATA

		160	190	250
DISPLACEMENT	[cc]	162	198	253
SPECIFIC TORQUE	[Nm/bar]	2.6	3.2	4.0
MAX. CONT. PRESSURE	[bar]	270	270	270
HYDROSTATIC TEST PRESSURE	[bar]	420	420	420
MAX. CONT. SPEED	[rpm]	950	800	750
PEAK SPEED (**)	[rpm]	1050	900	850
MAX. CONT. POWER (***)	[kW]	35	35	35
MAX. POWER	[kW]	50	50	50
MAX. CASE PRESSURE	[bar]	6	6	6
DRY WEIGHT	[kg]	42	42	42
TEMPERATURE RANGE (**)	[°C]	-30÷70	-30÷70	-30÷70

- (*) The standard distributor (D40) is shown. Please refer to distributors section (pag. 178-179) for different distributor interfaces.

- (**) Please refer to the hydraulic fluid recommendations (pag. 10-11).

- (***) Do not exceed maximum power.

- (****) For motor operation with a continuous duty cycle at maximum continuous power the flushing is usually required (see pag. 13). For more information please contact our technical department.

SHAFTS

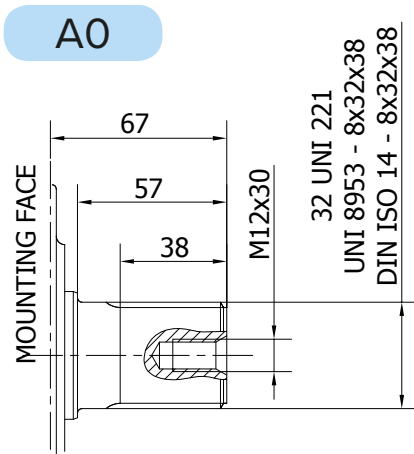

Available spline billet: SB2

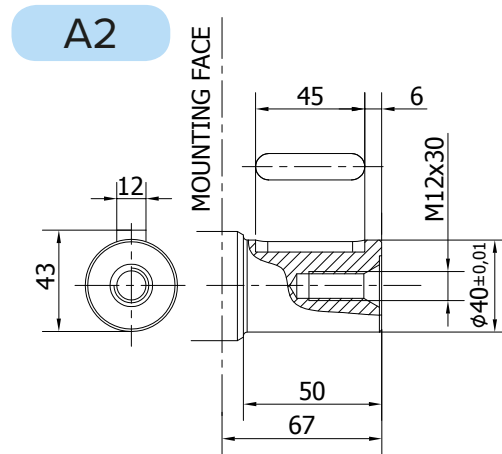

NOT AVAILABLE FOR
160 AND 250 cc

R8M 250-300-350-400/C300 H2

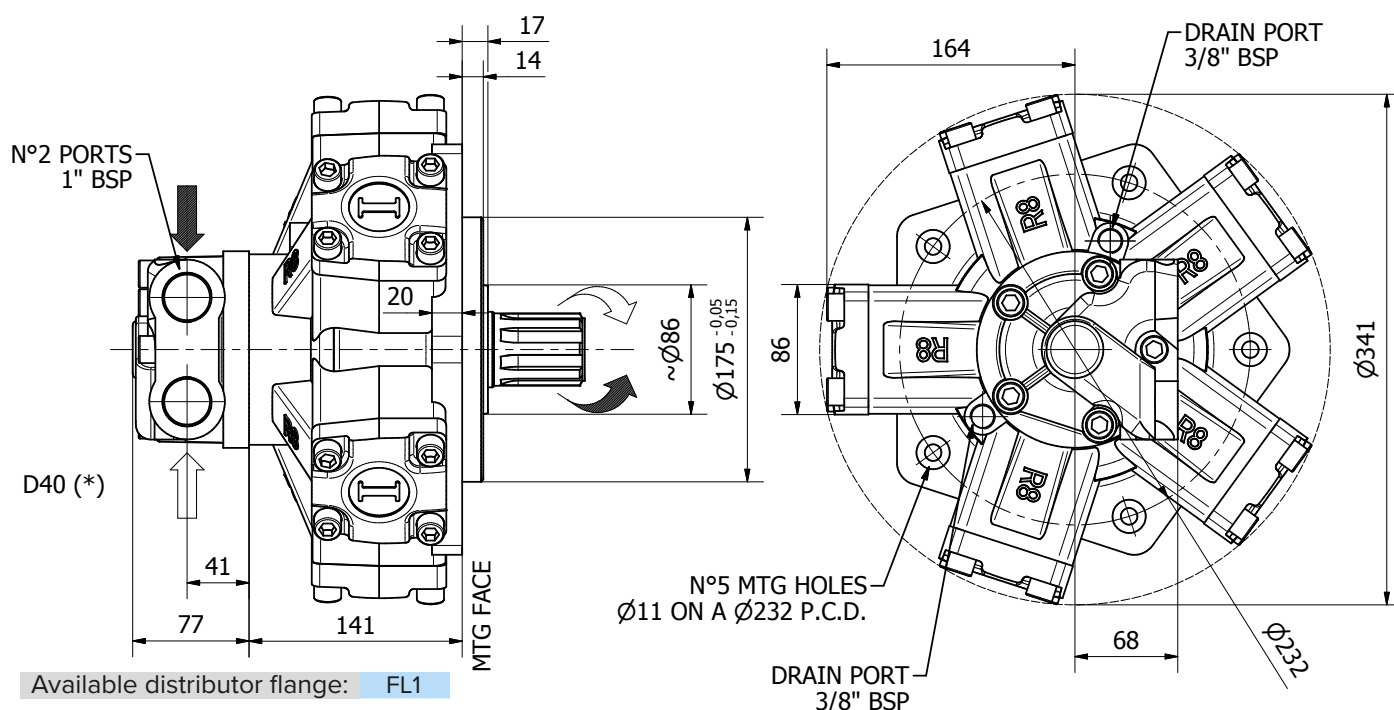

Available distributor flange: **FL1**

Refer to page 190-191
(distributor fitting D47)

TECHNICAL DATA

		250	300	350	400
DISPLACEMENT	[cc]	253	314	362	393
SPECIFIC TORQUE	[Nm/bar]	4.0	5.0	5.8	6.3
MAX. CONT. PRESSURE	[bar]	270	270	270	270
HYDROSTATIC TEST PRESSURE	[bar]	420	420	420	420
MAX. CONT. SPEED	[rpm]	750	750	650	600
PEAK SPEED (***)	[rpm]	850	850	750	700
MAX. CONT. POWER (****)	[kW]	35	35	35	35
MAX. POWER	[kW]	50	50	50	50
MAX. CASE PRESSURE	[bar]	6	6	6	6
DRY WEIGHT	[kg]	42	42	42	42
TEMPERATURE RANGE (**)	[°C]	-30÷70	-30÷70	-30÷70	-30÷70

- (*) The standard distributor (D40) is shown. Please refer to distributors section (pag. 178-179) for different distributor interfaces.

- (**) Please refer to the hydraulic fluid recommendations (pag. 10-11).

- (***) Do not exceed maximum power.

- (****) For motor operation with a continuous duty cycle at maximum continuous power the flushing is usually required (see pag. 13). For more information please contact our technical department.

SHAFTS

A0

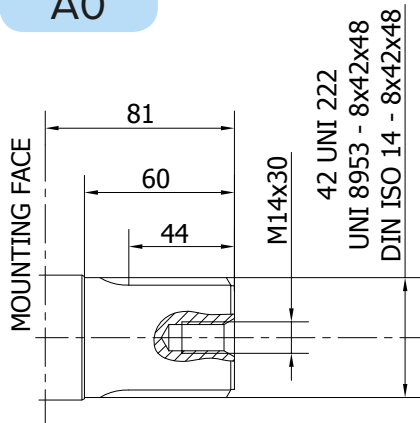

Available spline billet: SB15

A2

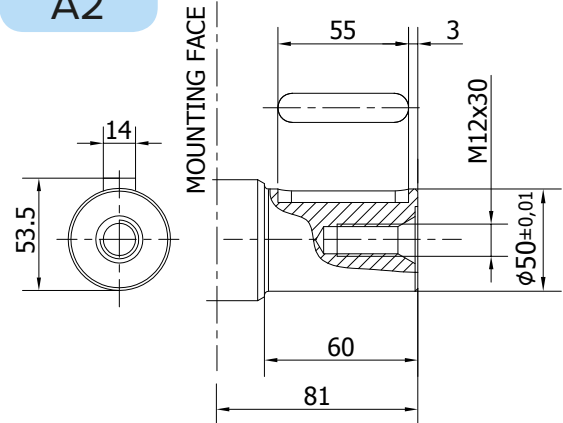

NOT AVAILABLE FOR
250 cc

A3

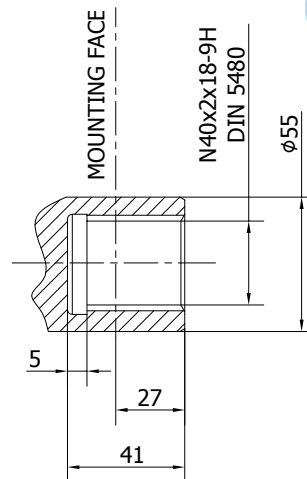

NOT AVAILABLE FOR
250 cc

SHAFTS

A0

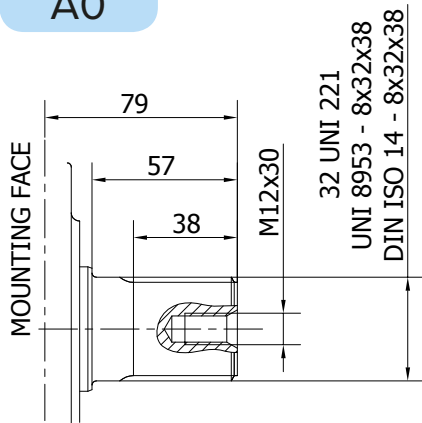

Available spline billet: SB2

A1

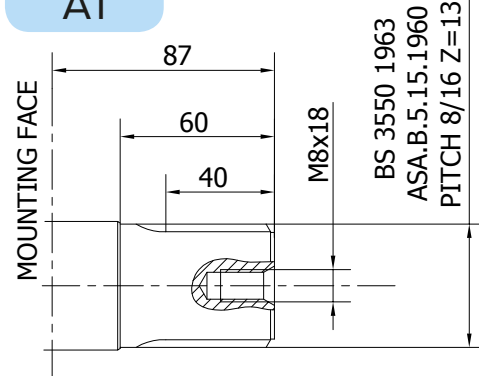

A2

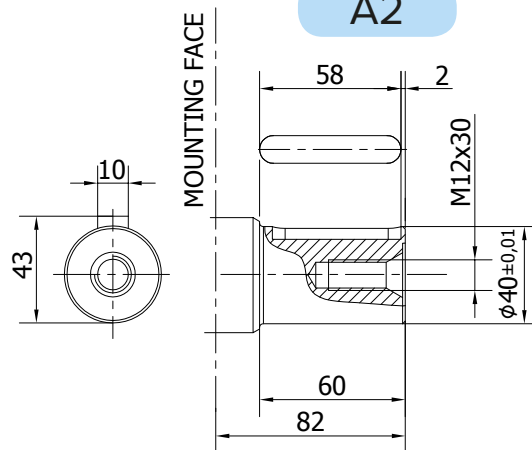

R8M H2/PH

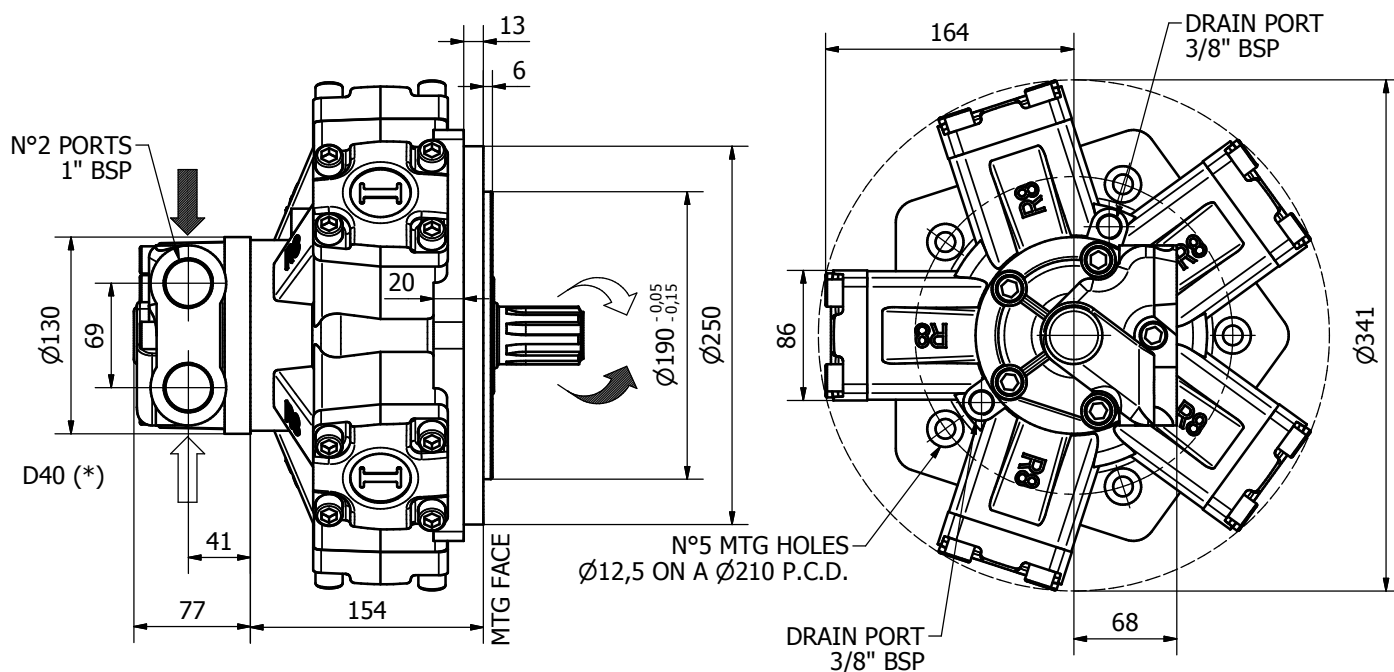

TECHNICAL DATA

		200	250	300	350	400	500	600
DISPLACEMENT	[cc]	198	253	314	362	424	492	584
SPECIFIC TORQUE	[Nm/bar]	3.2	4.0	5.0	5.8	6.7	7.8	9.3
MAX. CONT. PRESSURE	[bar]	270	270	270	270	270	260	250
HYDROSTATIC TEST PRESSURE	[bar]	420	420	420	420	420	420	420
MAX. CONT. SPEED	[rpm]	800	750	750	650	600	500	500
PEAK SPEED (***)	[rpm]	900	850	850	750	700	600	600
MAX. CONT. POWER (****)	[kW]	35	35	35	35	35	35	35
MAX. POWER	[kW]	50	50	50	50	50	50	50
MAX. CASE PRESSURE	[bar]	6	6	6	6	6	6	6
DRY WEIGHT	[kg]	42	42	42	42	42	42	42
TEMPERATURE RANGE (**)	[°C]	-30÷70	-30÷70	-30÷70	-30÷70	-30÷70	-30÷70	-30÷70

- (*) The standard distributor (D40) is shown. Please refer to distributors section (pag. 178-179) for different distributor interfaces.

- (**) Please refer to the hydraulic fluid recommendations (pag. 10-11).

- (***) Do not exceed maximum power.

- (****) For motor operation with a continuous duty cycle at maximum continuous power the flushing is usually required (see pag. 13). For more information please contact our technical department.

SHAFTS

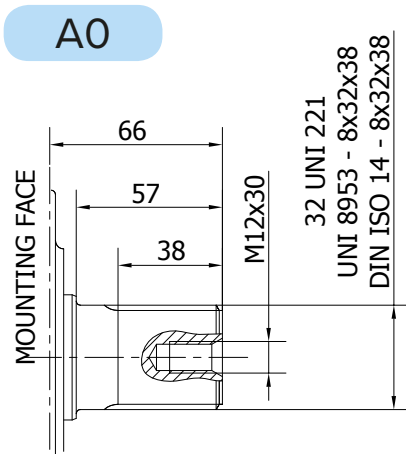

Available spline billet: SB2

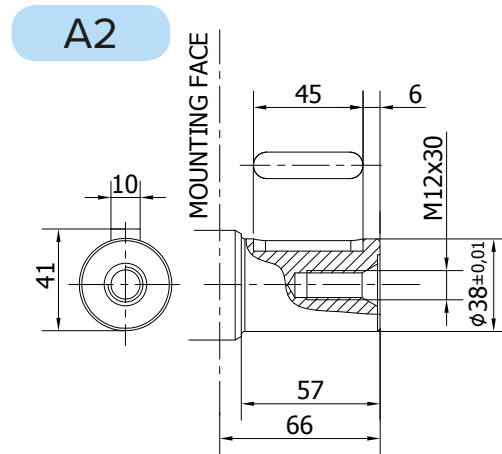

R8M H2/GM2

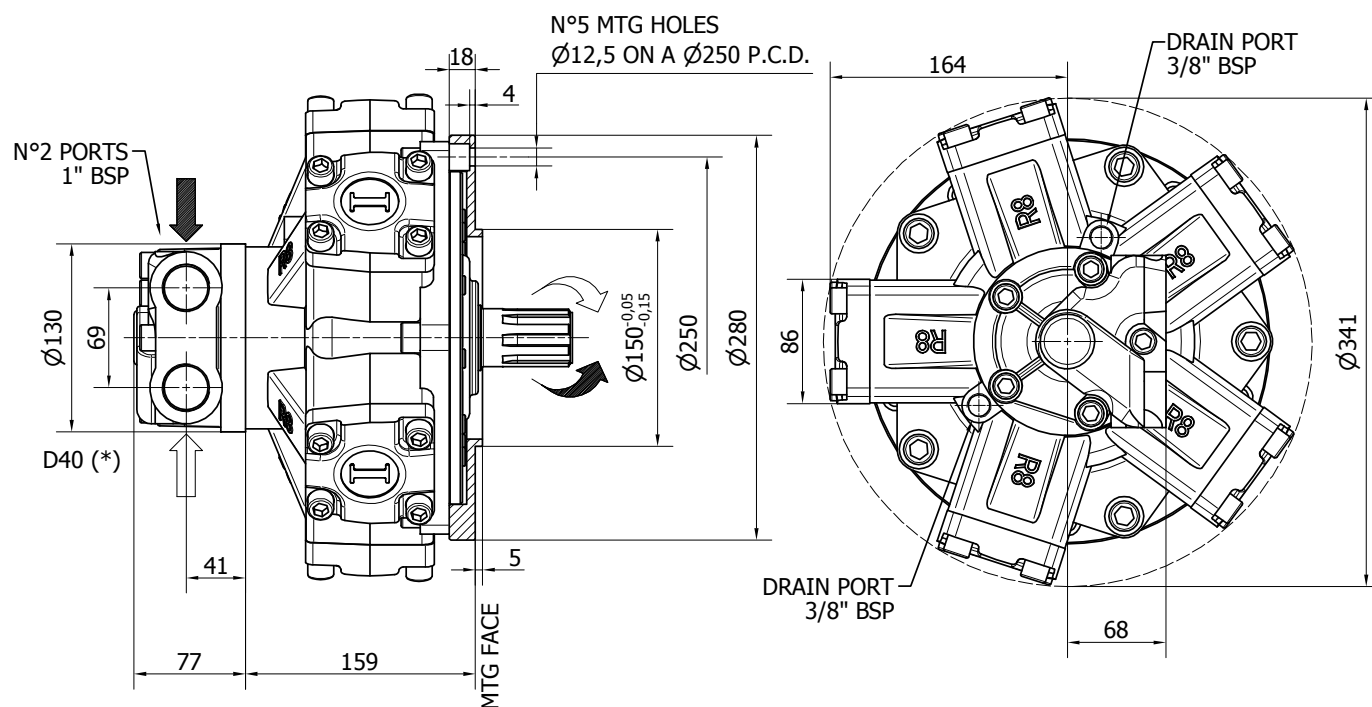

TECHNICAL DATA

		200	250	300	350	400	500	600
DISPLACEMENT	[cc]	198	253	314	362	424	492	584
SPECIFIC TORQUE	[Nm/bar]	3.2	4.0	5.0	5.8	6.7	7.8	9.3
MAX. CONT. PRESSURE	[bar]	270	270	270	270	270	260	250
HYDROSTATIC TEST PRESSURE	[bar]	420	420	420	420	420	420	420
MAX. CONT. SPEED	[rpm]	800	750	750	650	600	500	500
PEAK SPEED (***)	[rpm]	900	850	850	750	700	600	600
MAX. CONT. POWER (****)	[kW]	35	35	35	35	35	35	35
MAX. POWER	[kW]	50	50	50	50	50	50	50
MAX. CASE PRESSURE	[bar]	6	6	6	6	6	6	6
DRY WEIGHT	[kg]	42	42	42	42	42	42	42
TEMPERATURE RANGE (**)	[°C]	-30÷70	-30÷70	-30÷70	-30÷70	-30÷70	-30÷70	-30÷70

- (*) The standard distributor (D40) is shown. Please refer to distributors section (pag. 178-179) for different distributor interfaces.

- (**) Please refer to the hydraulic fluid recommendations (pag. 10-11).

- (***) Do not exceed maximum power.

- (****) For motor operation with a continuous duty cycle at maximum continuous power the flushing is usually required (see pag. 13). For more information please contact our technical department.

SHAFTS

A0

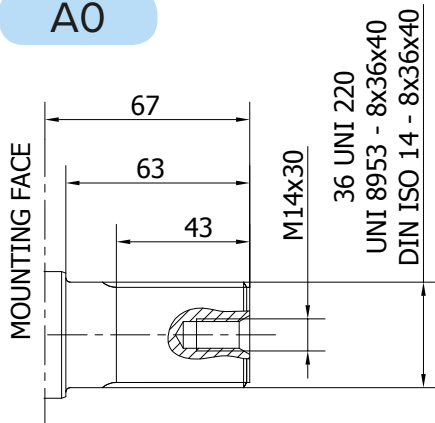

Available spline billet: SB3

A2

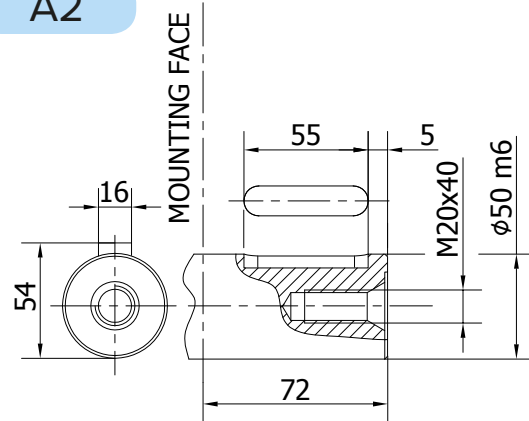

A3

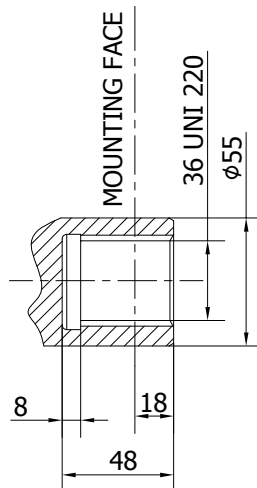

Available spline bar: B8078

R8M H2/S

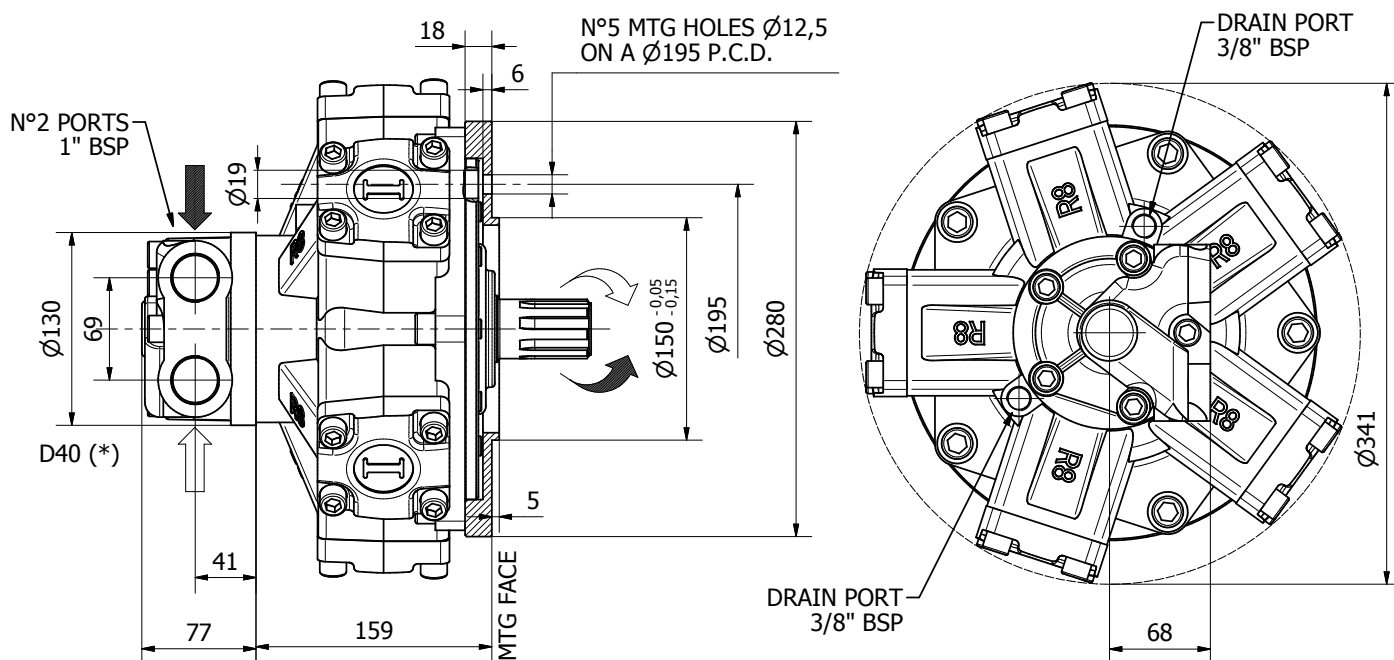

TECHNICAL DATA

		200	250	300	350	400	500	600
DISPLACEMENT	[cc]	198	253	314	362	424	492	584
SPECIFIC TORQUE	[Nm/bar]	3.2	4.0	5.0	5.8	6.7	7.8	9.3
MAX. CONT. PRESSURE	[bar]	270	270	270	270	270	260	250
HYDROSTATIC TEST PRESSURE	[bar]	420	420	420	420	420	420	420
MAX. CONT. SPEED	[rpm]	800	750	750	650	600	500	500
PEAK SPEED (***)	[rpm]	900	850	850	750	700	600	600
MAX. CONT. POWER (****)	[kW]	35	35	35	35	35	35	35
MAX. POWER	[kW]	50	50	50	50	50	50	50
MAX. CASE PRESSURE	[bar]	6	6	6	6	6	6	6
DRY WEIGHT	[kg]	42	42	42	42	42	42	42
TEMPERATURE RANGE (**)	[°C]	-30÷70	-30÷70	-30÷70	-30÷70	-30÷70	-30÷70	-30÷70

- (*) The standard distributor (D40) is shown. Please refer to distributors section (pag. 178-179) for different distributor interfaces.

- (**) Please refer to the hydraulic fluid recommendations (pag. 10-11).

- (***) Do not exceed maximum power.

- (****) For motor operation with a continuous duty cycle at maximum continuous power the flushing is usually required (see pag. 13). For more information please contact our technical department.

SHAFTS

A0

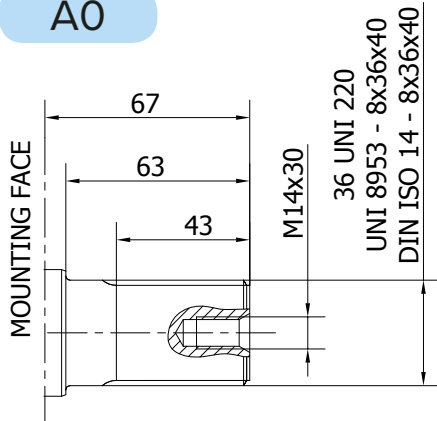

Available spline billet: SB3

A2

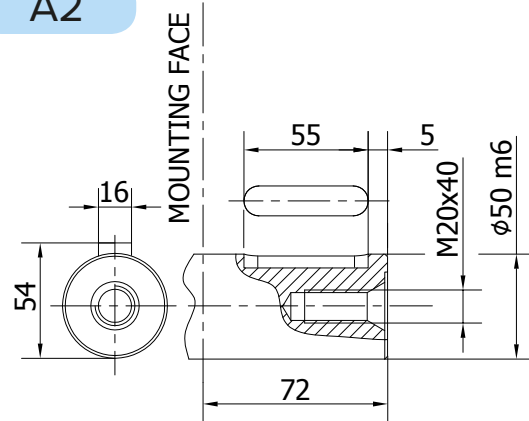

A3

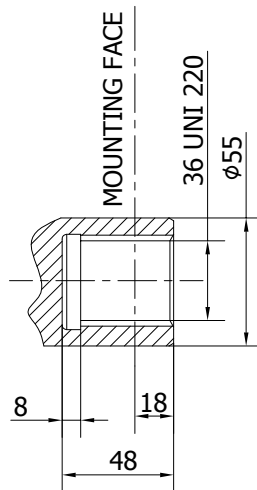

Available spline bar: B8078

R8M H2 - PERFORMANCE CURVES

R8M 160 H2

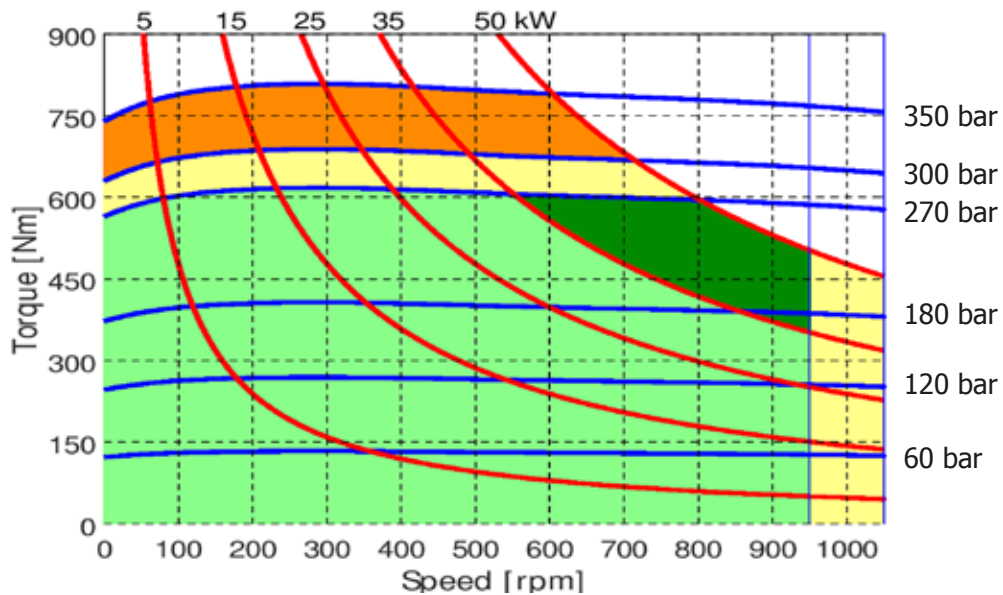

R8M 190 H2

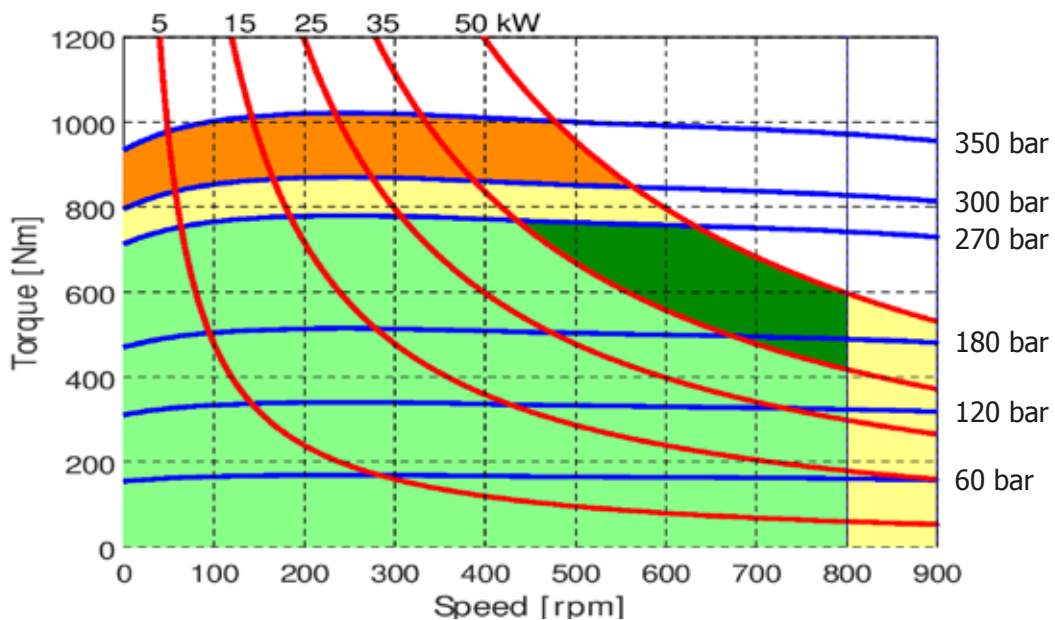

- Continuous operation
- Continuous operation with flushing or intermittent operation (see below for intermittent operation)
- Intermittent operation: permitted for a 15% of duty cycle, for 3 minutes maximum period
- Peak operation: permitted for very short periods (3-5 seconds every 10-15 minutes)

The above diagrams are referring to the hydraulic motor working with a fluid in ideal conditions (viscosity at 40 cSt). In case the working temperature increases and viscosity reach values under the recommended values (see hydraulic fluid recommendations) flushing must be performed or ISO oil grade must be changed. The working temperature must not overcome 70 °C.

R8M 200 H2

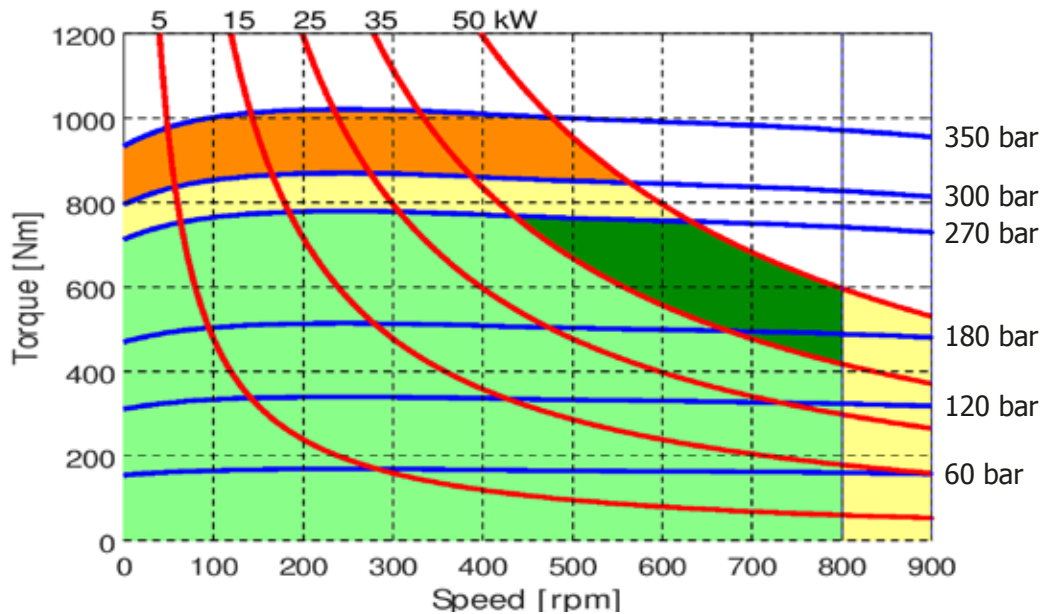

R8M 250 H2

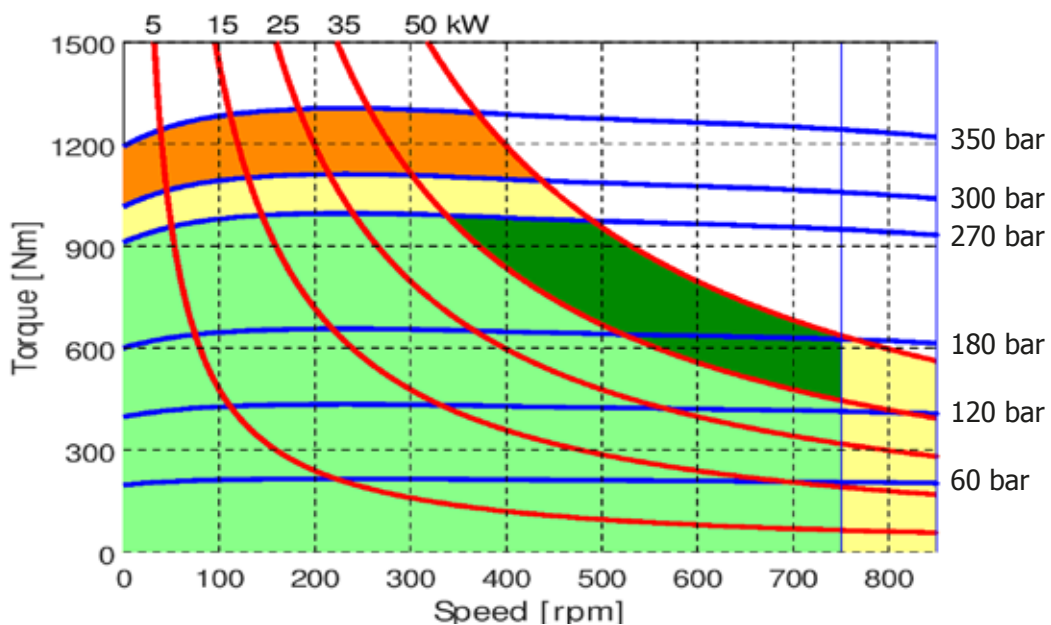

- Continuous operation
- Continuous operation with flushing or intermittent operation (see below for intermittent operation)
- Intermittent operation: permitted for a 15% of duty cycle, for 3 minutes maximum period
- Peak operation: permitted for very short periods (3-5 seconds every 10-15 minutes)

The above diagrams are referring to the hydraulic motor working with a fluid in ideal conditions (viscosity at 40 cSt). In case the working temperature increases and viscosity reach values under the recommended values (see hydraulic fluid recommendations) flushing must be performed or ISO oil grade must be changed. The working temperature must not overcome 70 °C.

R8M H2 - PERFORMANCE CURVES

R8M 300 H2

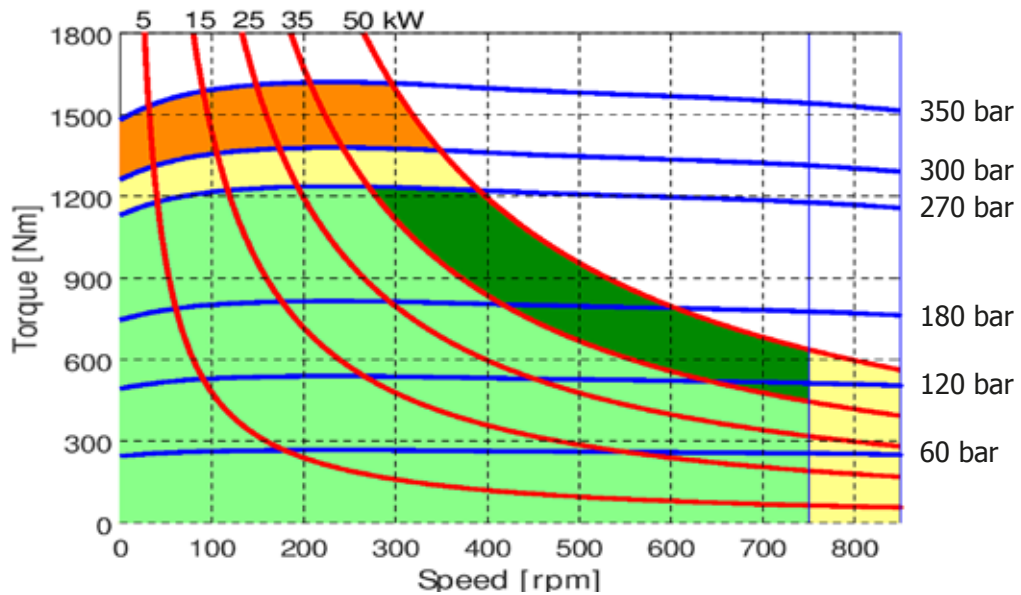

R8M 350 H2

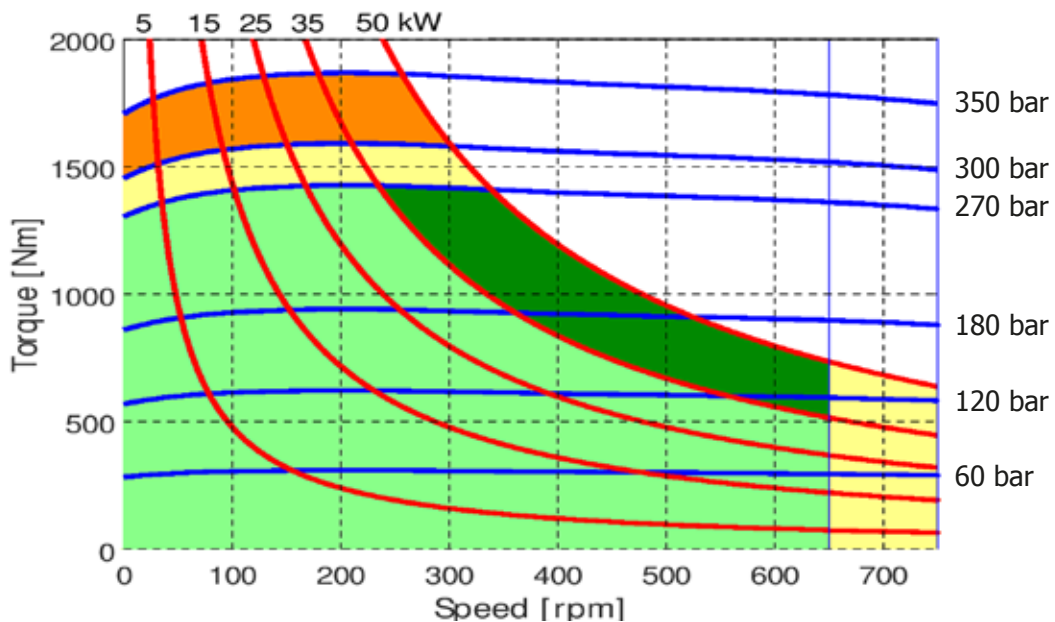

- Continuous operation
- Continuous operation with flushing or intermittent operation (see below for intermittent operation)
- Intermittent operation: permitted for a 15% of duty cycle, for 3 minutes maximum period
- Peak operation: permitted for very short periods (3-5 seconds every 10-15 minutes)

The above diagrams are referring to the hydraulic motor working with a fluid in ideal conditions (viscosity at 40 cSt). In case the working temperature increases and viscosity reach values under the recommended values (see hydraulic fluid recommendations) flushing must be performed or ISO oil grade must be changed. The working temperature must not overcome 70 °C.

R8M 400 H2

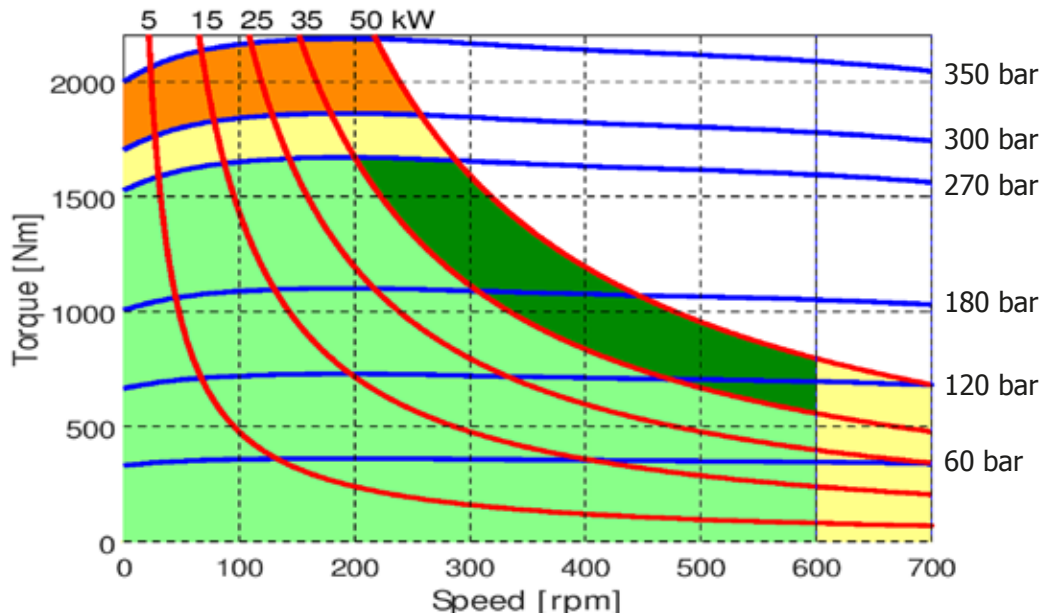

R8M 500 H2

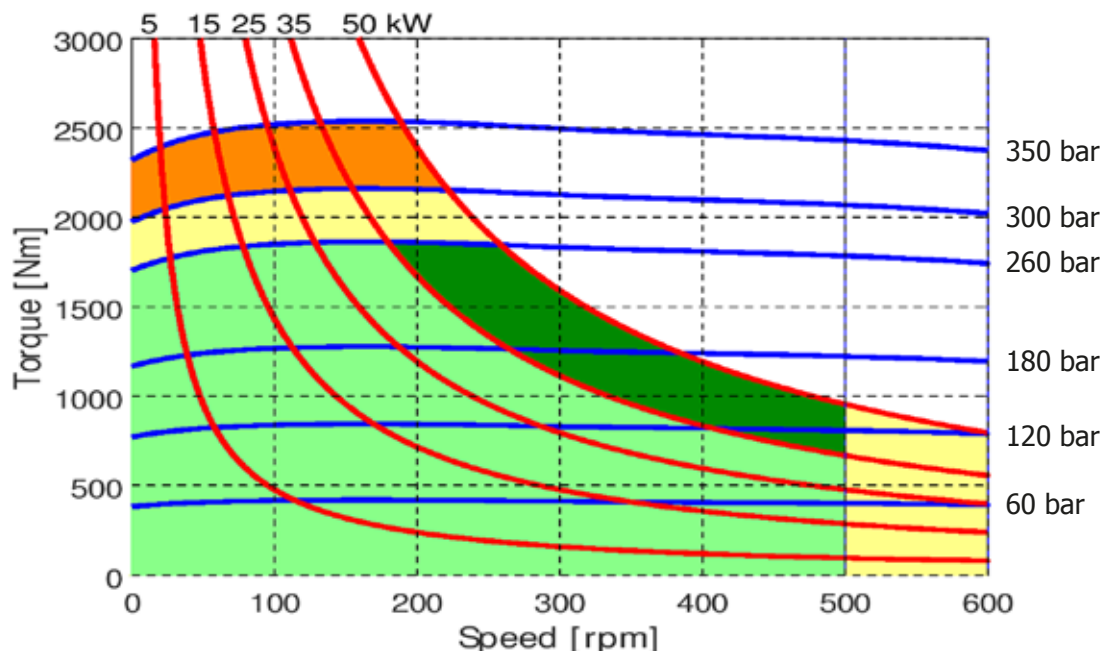

- Continuous operation
- Continuous operation with flushing or intermittent operation (see below for intermittent operation)
- Intermittent operation: permitted for a 15% of duty cycle, for 3 minutes maximum period
- Peak operation: permitted for very short periods (3-5 seconds every 10-15 minutes)

The above diagrams are referring to the hydraulic motor working with a fluid in ideal conditions (viscosity at 40 cSt). In case the working temperature increases and viscosity reach values under the recommended values (see hydraulic fluid recommendations) flushing must be performed or ISO oil grade must be changed. The working temperature must not overcome 70 °C.

R8M H2 - PERFORMANCE CURVES

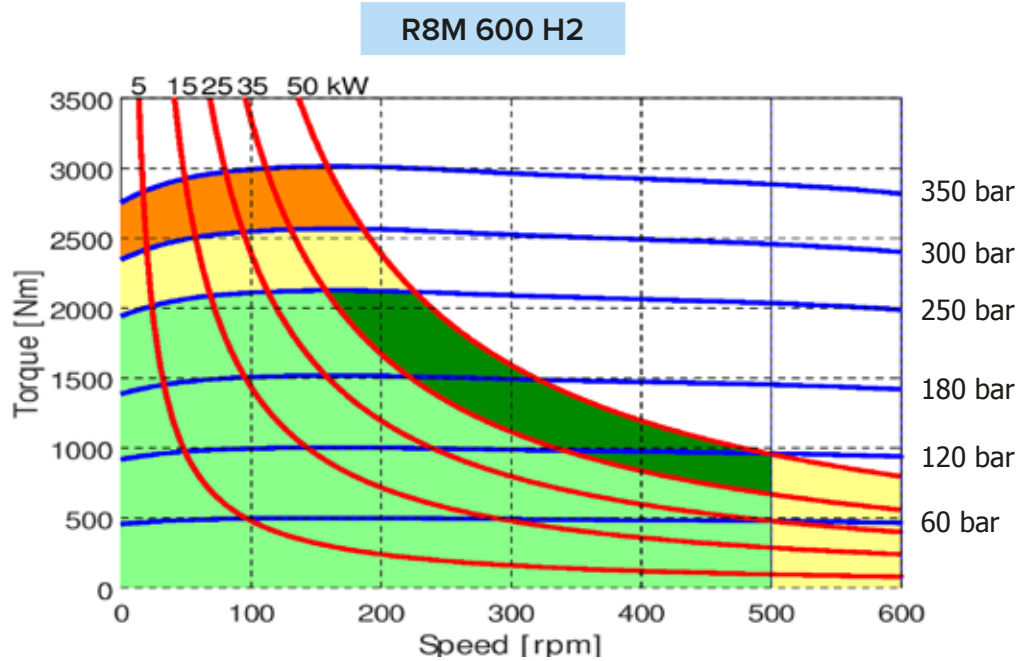

- Continuous operation
- Continuous operation with flushing or intermittent operation (see below for intermittent operation)
- Intermittent operation: permitted for a 15% of duty cycle, for 3 minutes maximum period
- Peak operation: permitted for very short periods (3-5 seconds every 10-15 minutes)

The above diagrams are referring to the hydraulic motor working with a fluid in ideal conditions (viscosity at 40 cSt). In case the working temperature increases and viscosity reach values under the recommended values (see hydraulic fluid recommendations) flushing must be performed or ISO oil grade must be changed. The working temperature must not overcome 70 °C.

BEARING LIFE

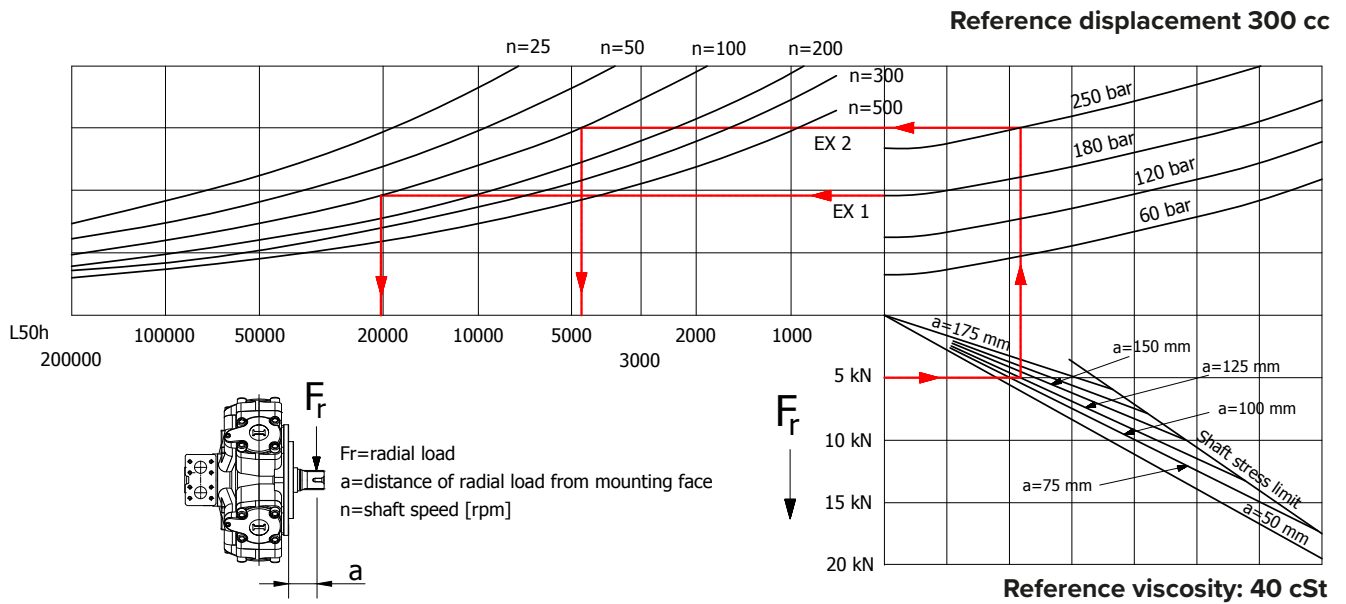

Example:

We suppose (EX1): $p=120$ [bar], $n=50$ [rpm]; we obtain an average lifetime of 200000 [h].

If we suppose (EX2): $F_r=10$ [kN], $a=50$ [mm], $n=50$ [rpm] and $p=250$ [bar] we obtain an average lifetime of 12500 [h].

The above data are referring to the R8M H2 series motors, displacement 300 cc.

R8M H2 - ORDERING CODE

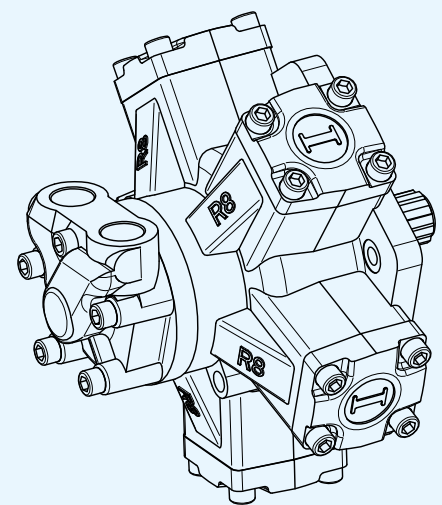
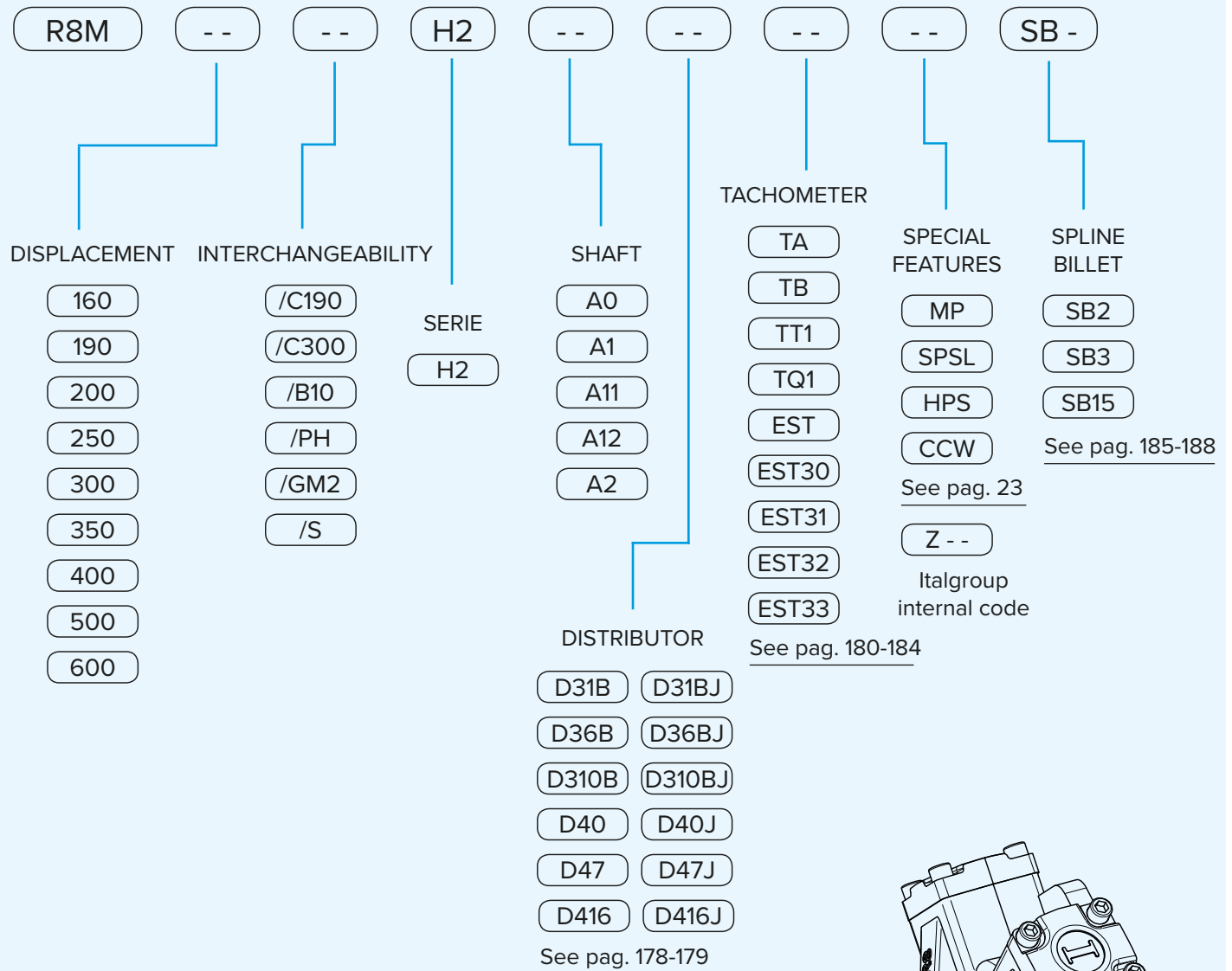

EXAMPLES:

- R8M 190/C190 H2 A0 D40
- R8M 300 H2 A2 D310B
- R8M 400/C300 H2 A3 D47 CCW

R 8 M H 3

R8M H3	Pag. 72 - 73
R8M H3/C	Pag. 74 - 75
R8M H3/B30	Pag. 76 - 77
R8M 800 H3	Pag. 78 - 79
R8M 800/N H3	Pag. 80 - 81
R8M H3/GM3	Pag. 82 - 83
R8M H3/S	Pag. 84 - 85
R8M H3 - PERFORMANCE CURVES	Pag. 86 - 90
R8M H3 - ORDERING CODE	Pag. 91

R8M H3

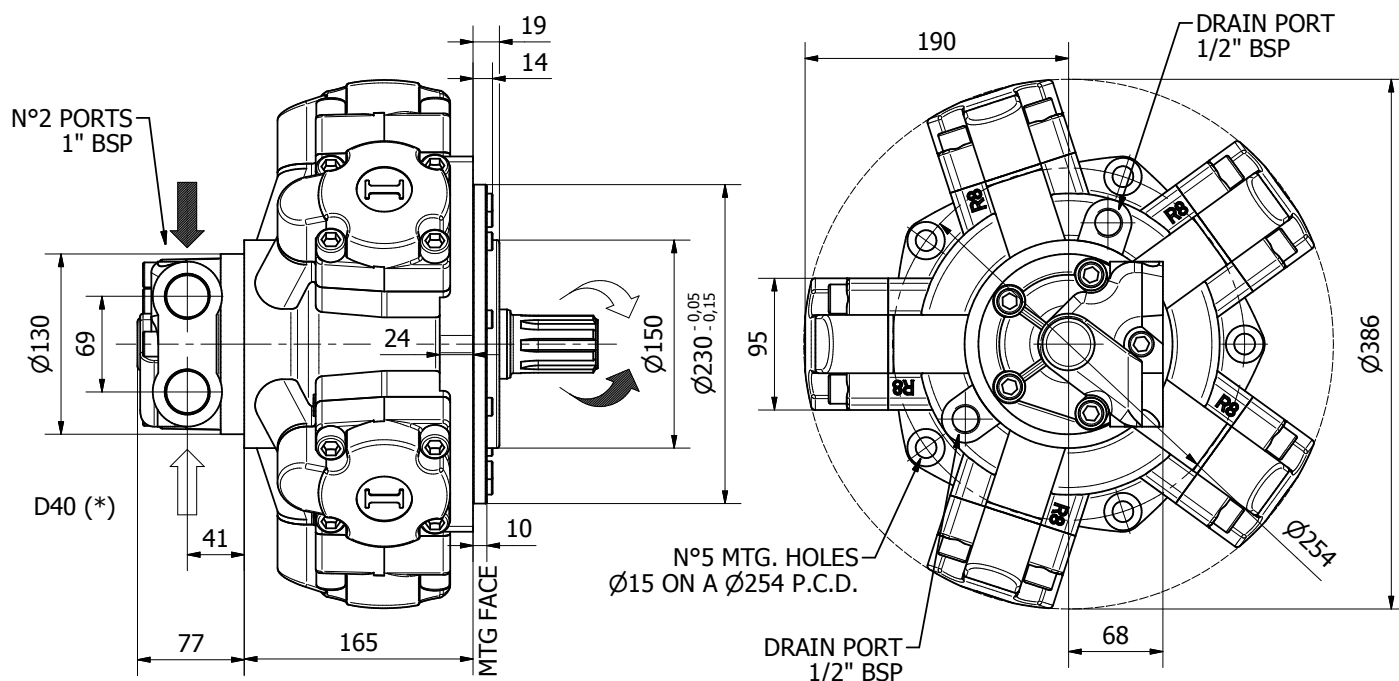

TECHNICAL DATA

		350	400	450	500	600	650	700
DISPLACEMENT	[cc]	349	397	452	491	594	660	707
SPECIFIC TORQUE	[Nm/bar]	5.6	6.3	7.2	7.8	9.4	10.5	11.2
MAX. CONT. PRESSURE	[bar]	270	270	270	270	270	250	250
HYDROSTATIC TEST PRESSURE	[bar]	420	420	420	420	420	420	420
MAX. CONT. SPEED	[rpm]	630	600	600	600	550	500	450
PEAK SPEED (***)	[rpm]	700	680	680	680	630	580	500
MAX. CONT. POWER (****)	[kW]	47	47	47	47	47	47	47
MAX. POWER	[kW]	70	70	70	70	70	70	70
MAX. CASE PRESSURE	[bar]	6	6	6	6	6	6	6
DRY WEIGHT	[kg]	68	68	68	68	68	68	68
TEMPERATURE RANGE (**)	[°C]	-30÷70	-30÷70	-30÷70	-30÷70	-30÷70	-30÷70	-30÷70

- (*) The standard distributor (D40) is shown. Please refer to distributors section (pag. 178-179) for different distributor interfaces.

- (**) Please refer to the hydraulic fluid recommendations (pag. 10-11).

- (***) Do not exceed maximum power.

- (****) For motor operation with a continuous duty cycle at maximum continuous power the flushing is usually required (see pag. 13). For more information please contact our technical department.

SHAFTS

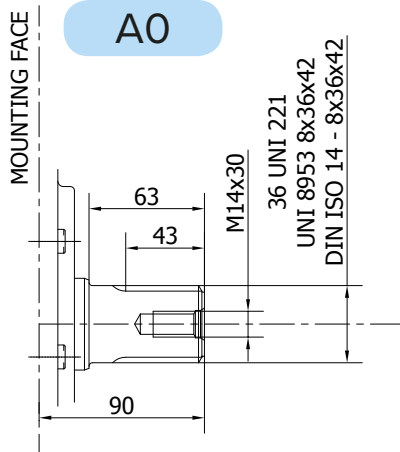

Available spline billet: **SB3**

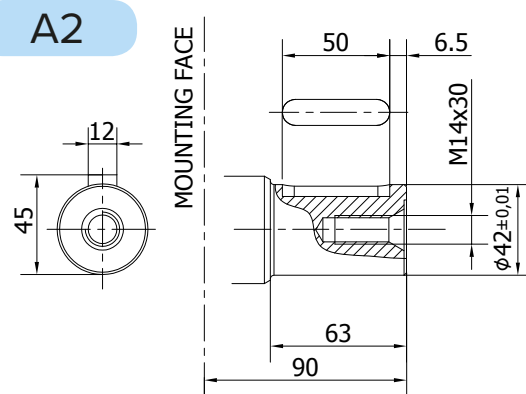

NOT AVAILABLE FOR
350 cc

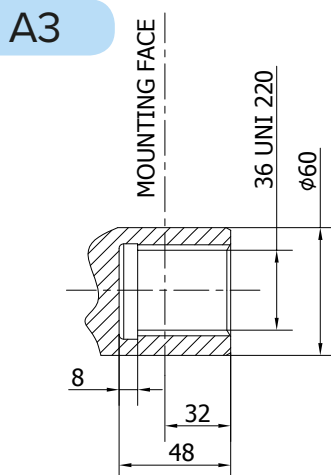

Available spline bar: **B8078**

NOT AVAILABLE FOR
350 cc

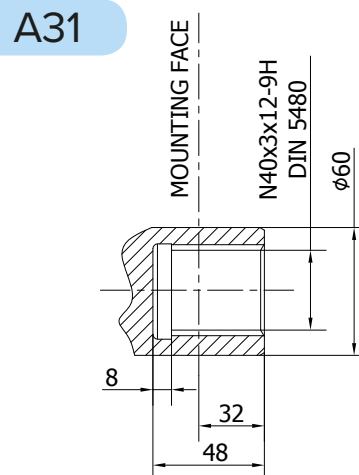

Available spline bar: **B8076**

NOT AVAILABLE FOR
350 cc

R8M H3/C

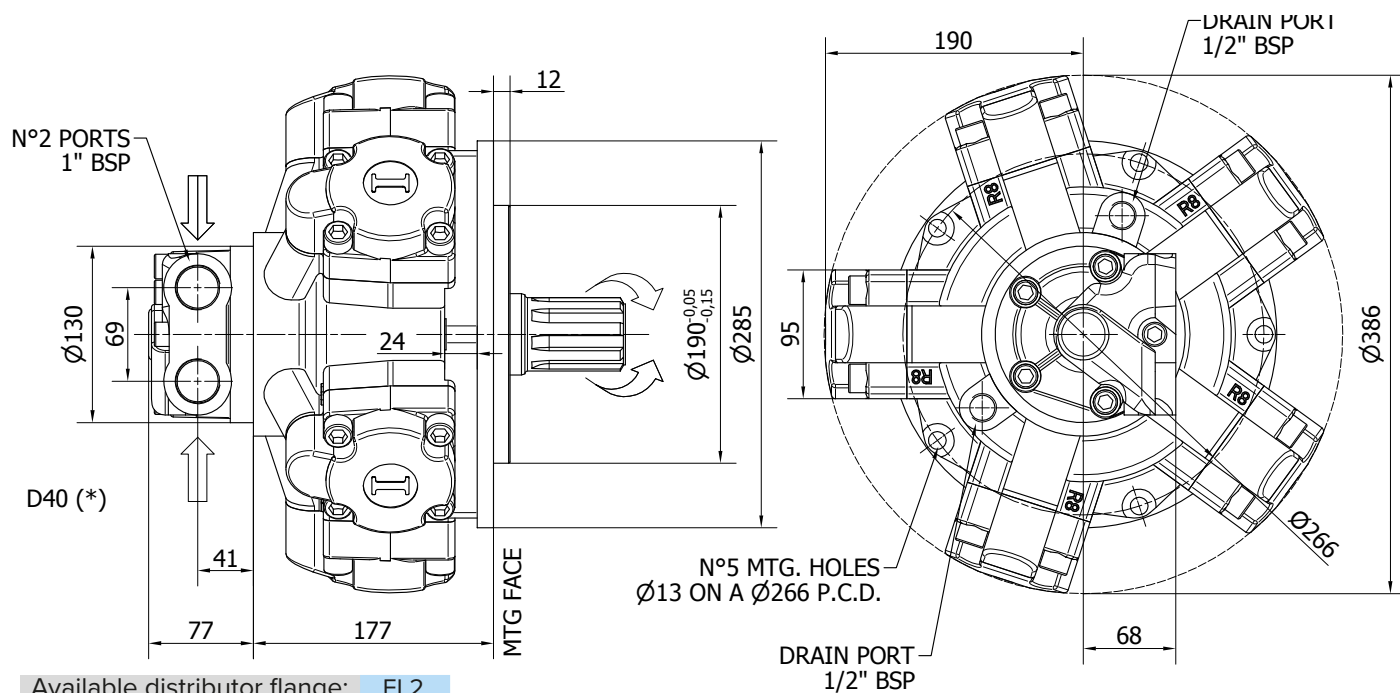

Available distributor flange: **FL2**

Refer to page 190-191
(distributor fitting D47)

TECHNICAL DATA

		400	450	500	600	650	700
DISPLACEMENT	[cc]	397	452	491	594	660	707
SPECIFIC TORQUE	[Nm/bar]	6.3	7.2	7.8	9.4	10.5	11.2
MAX. CONT. PRESSURE	[bar]	270	270	270	270	250	250
HYDROSTATIC TEST PRESSURE	[bar]	420	420	420	420	420	420
MAX. CONT. SPEED	[rpm]	600	600	600	550	500	450
PEAK SPEED (***)	[rpm]	680	680	680	630	580	500
MAX. CONT. POWER (****)	[kW]	47	47	47	47	47	47
MAX. POWER	[kW]	70	70	70	70	70	70
MAX. CASE PRESSURE	[bar]	6	6	6	6	6	6
DRY WEIGHT	[kg]	68	68	68	68	68	68
TEMPERATURE RANGE (**)	[°C]	-30÷70	-30÷70	-30÷70	-30÷70	-30÷70	-30÷70

- (*) The standard distributor (D40) is shown. Please refer to distributors section (pag. 178-179) for different distributor interfaces.

- (**) Please refer to the hydraulic fluid recommendations (pag. 10-11).

- (***) Do not exceed maximum power.

- (****) For motor operation with a continuous duty cycle at maximum continuous power the flushing is usually required (see pag. 13). For more information please contact our technical department.

SHAFTS

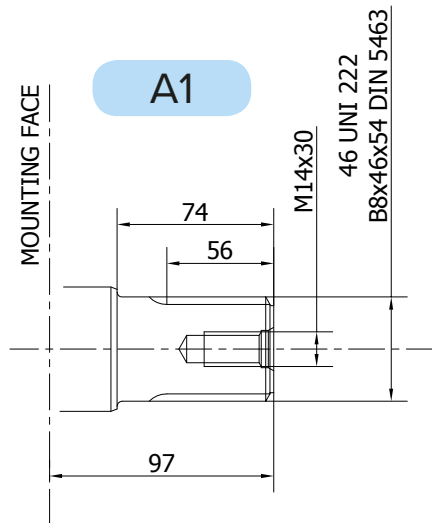

Available spline billet: SB5

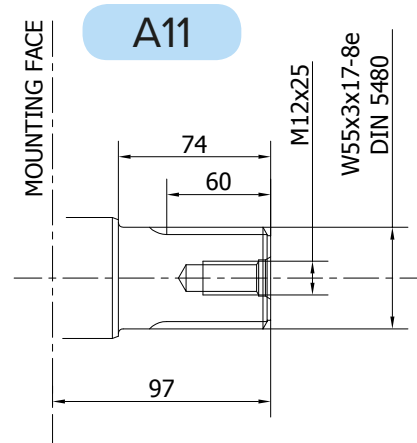

Available spline billet: SB30

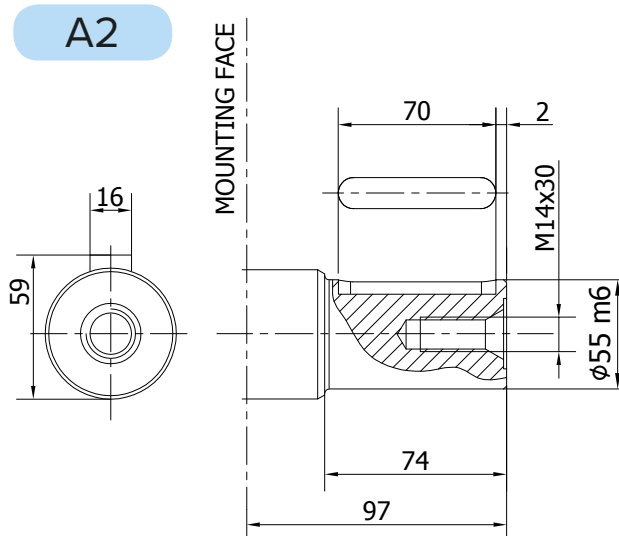

R8M H3/B30

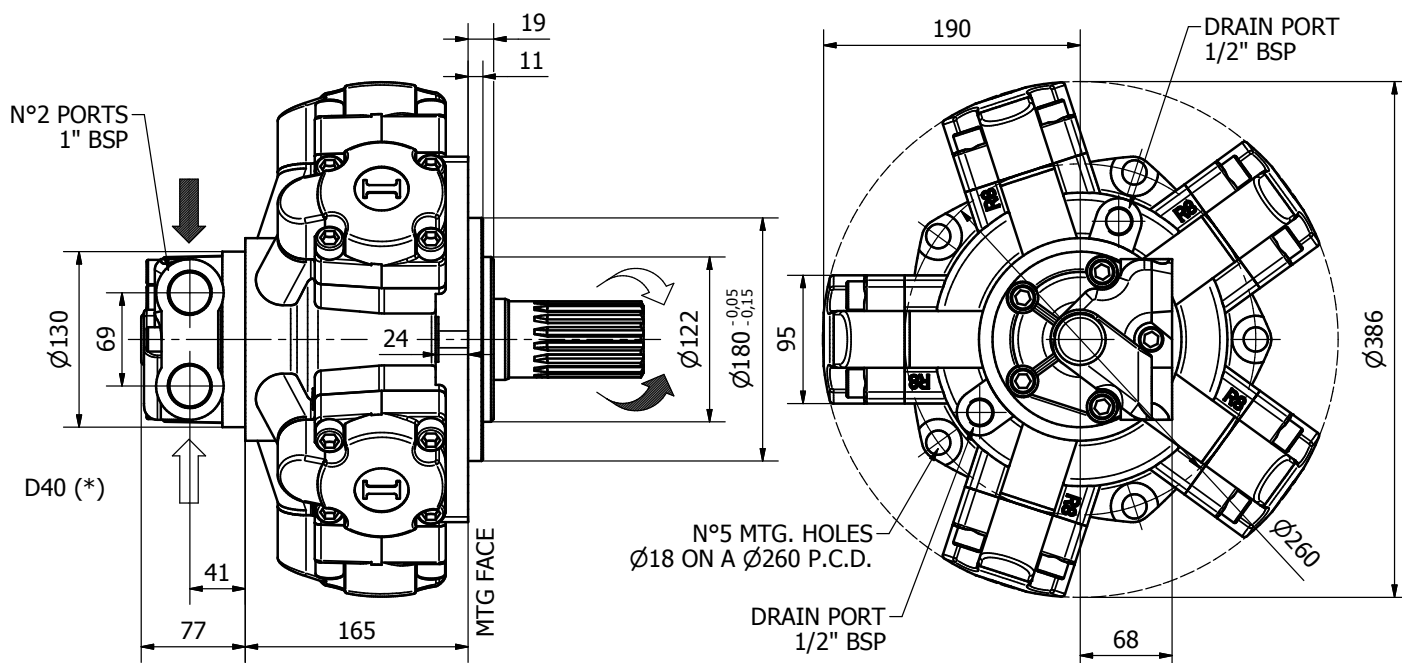

TECHNICAL DATA

		400	450	500	600	650	700
DISPLACEMENT	[cc]	397	452	491	594	660	707
SPECIFIC TORQUE	[Nm/bar]	6.3	7.2	7.8	9.4	10.5	11.2
MAX. CONT. PRESSURE	[bar]	270	270	270	270	250	250
HYDROSTATIC TEST PRESSURE	[bar]	420	420	420	420	420	420
MAX. CONT. SPEED	[rpm]	600	600	600	550	500	450
PEAK SPEED (***)	[rpm]	680	680	680	630	580	500
MAX. CONT. POWER (****)	[kW]	47	47	47	47	47	47
MAX. POWER	[kW]	70	70	70	70	70	70
MAX. CASE PRESSURE	[bar]	6	6	6	6	6	6
DRY WEIGHT	[kg]	68	68	68	68	68	68
TEMPERATURE RANGE (**)	[°C]	-30÷70	-30÷70	-30÷70	-30÷70	-30÷70	-30÷70

- (*) The standard distributor (D40) is shown. Please refer to distributors section (pag. 178-179) for different distributor interfaces.

- (**) Please refer to the hydraulic fluid recommendations (pag. 10-11).

- (***) Do not exceed maximum power.

- (****) For motor operation with a continuous duty cycle at maximum continuous power the flushing is usually required (see pag. 13). For more information please contact our technical department.

SHAFTS

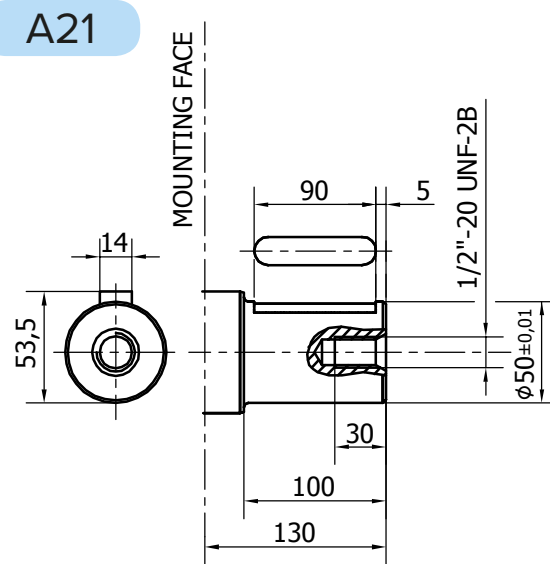
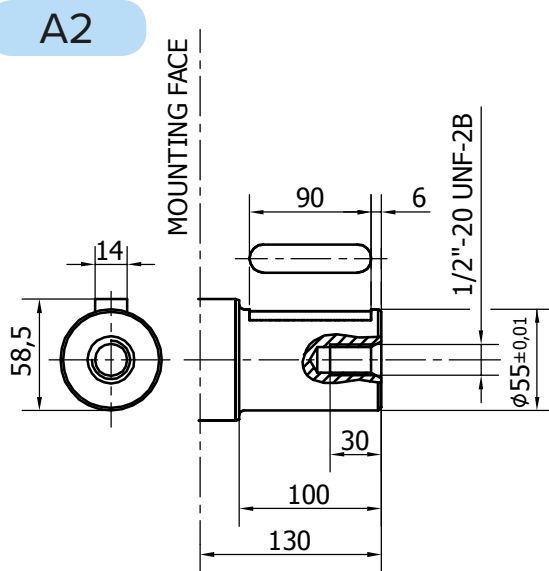
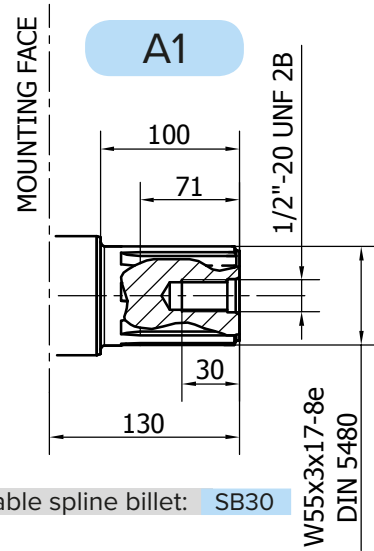
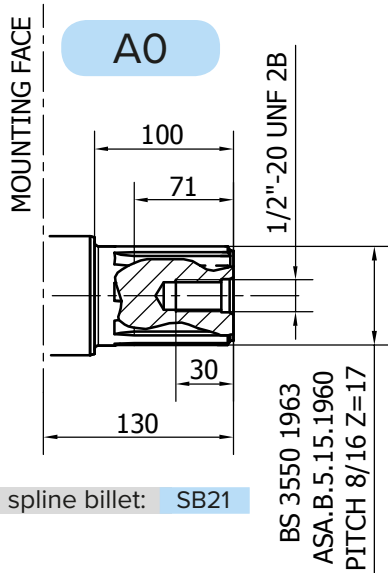

R8M 800 H3

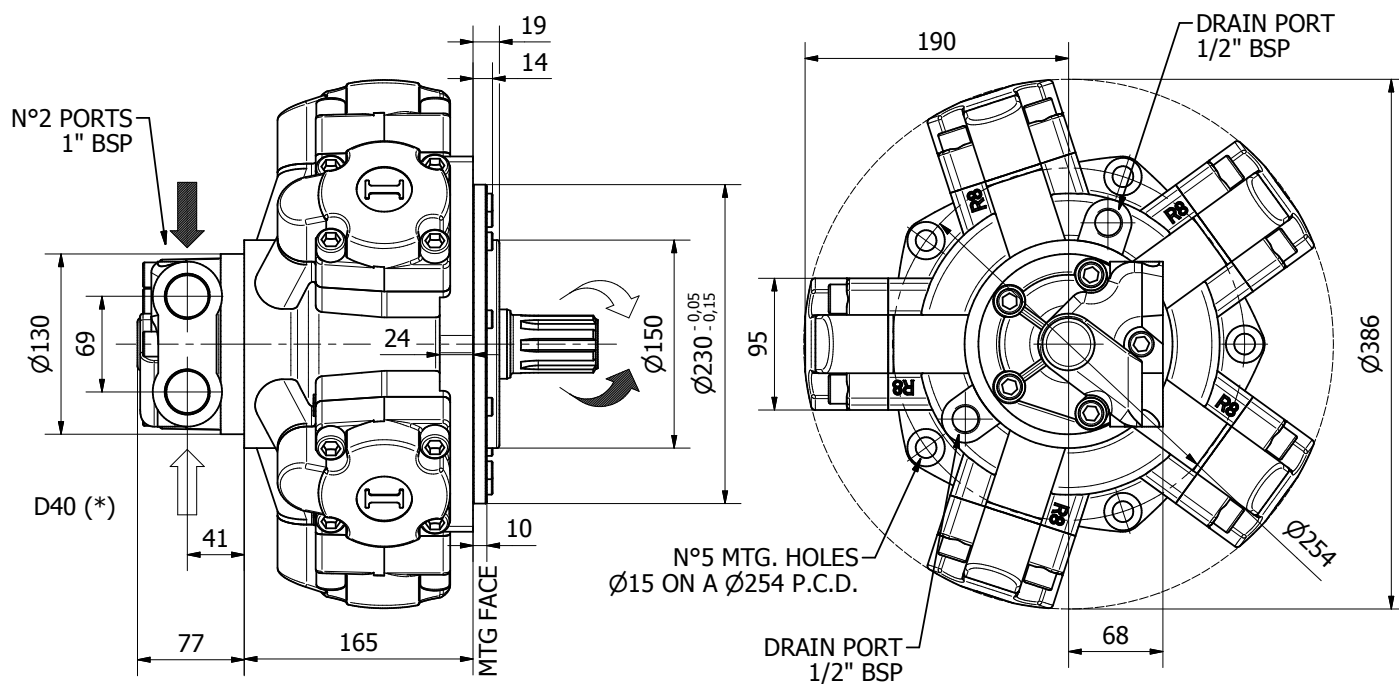

TECHNICAL DATA

		800
DISPLACEMENT	[cc]	791
SPECIFIC TORQUE	[Nm/bar]	12.6
MAX. CONT. PRESSURE	[bar]	250
HYDROSTATIC TEST PRESSURE	[bar]	420
MAX. CONT. SPEED	[rpm]	400
PEAK SPEED (***)	[rpm]	450
MAX. CONT. POWER (****)	[kW]	47
MAX. POWER	[kW]	70
MAX. CASE PRESSURE	[bar]	6
DRY WEIGHT	[kg]	68
TEMPERATURE RANGE (**)	[°C]	-30÷70

- (*) The standard distributor (D40) is shown. Please refer to distributors section (pag. 178-179) for different distributor interfaces.

- (**) Please refer to the hydraulic fluid recommendations (pag. 10-11).

- (***) Do not exceed maximum power.

- (****) For motor operation with a continuous duty cycle at maximum continuous power the flushing is usually required (see pag. 13). For more information please contact our technical department.

SHAFTS

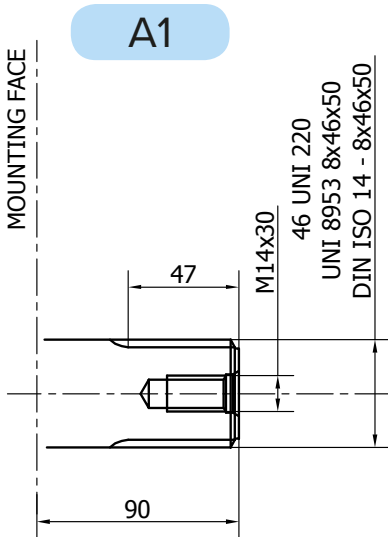

Available spline billet: SB4

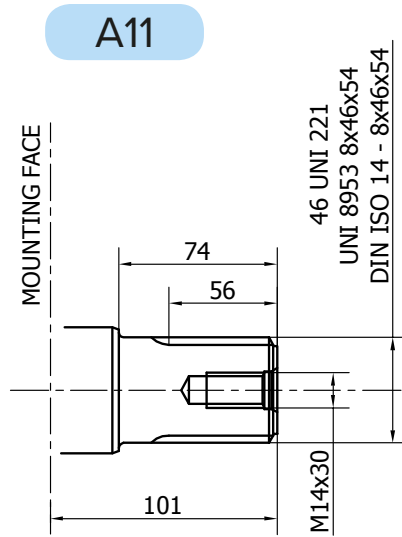

Available spline billet: SB5

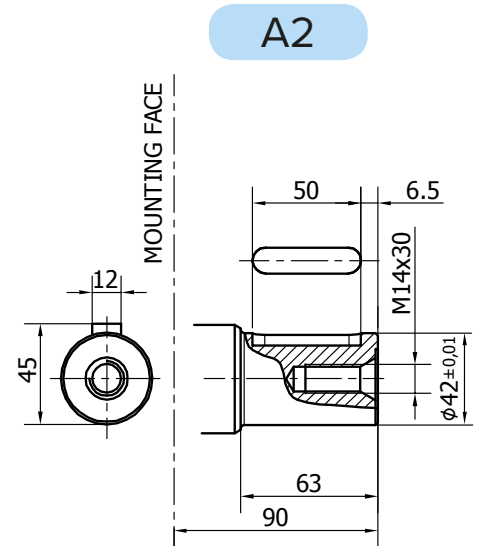

A21

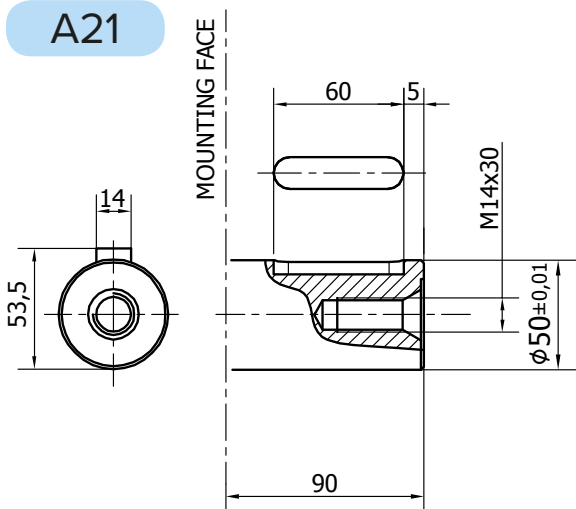

A22

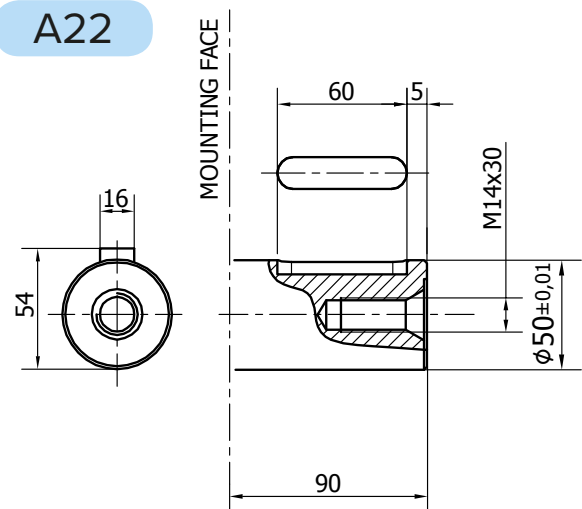

SHAFTS

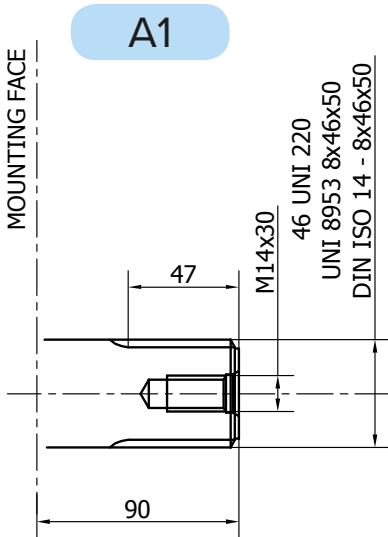

Available spline billet: SB4

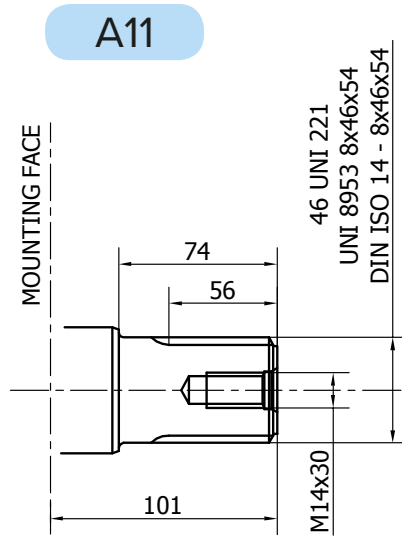

Available spline billet: SB5

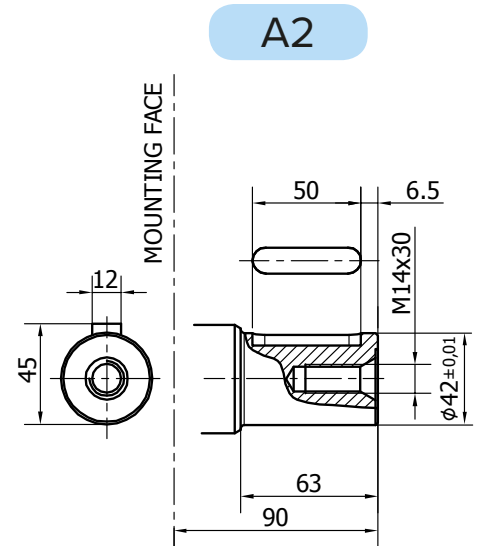

A21

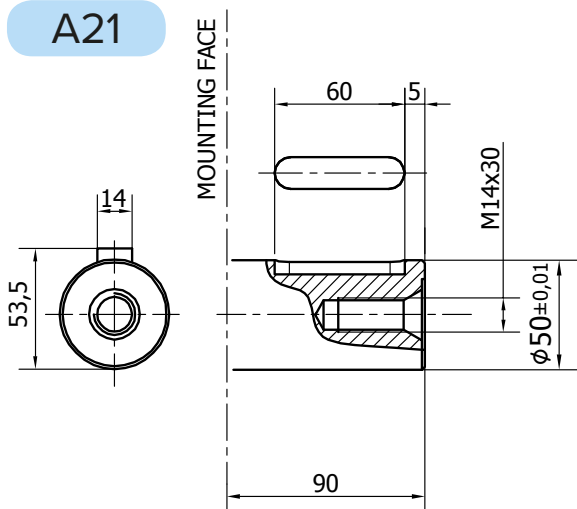

A22

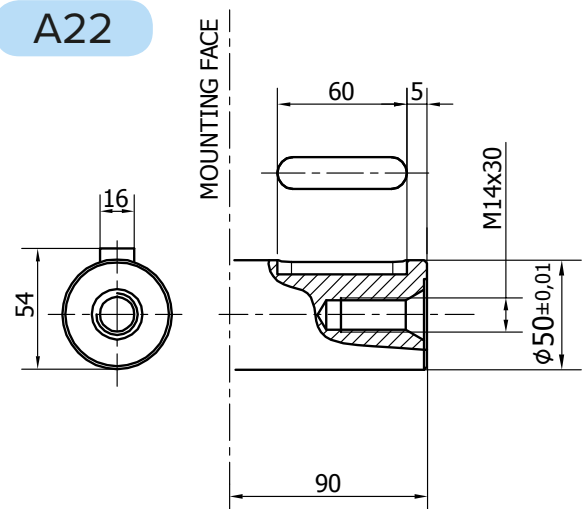

R8M H3/GM3

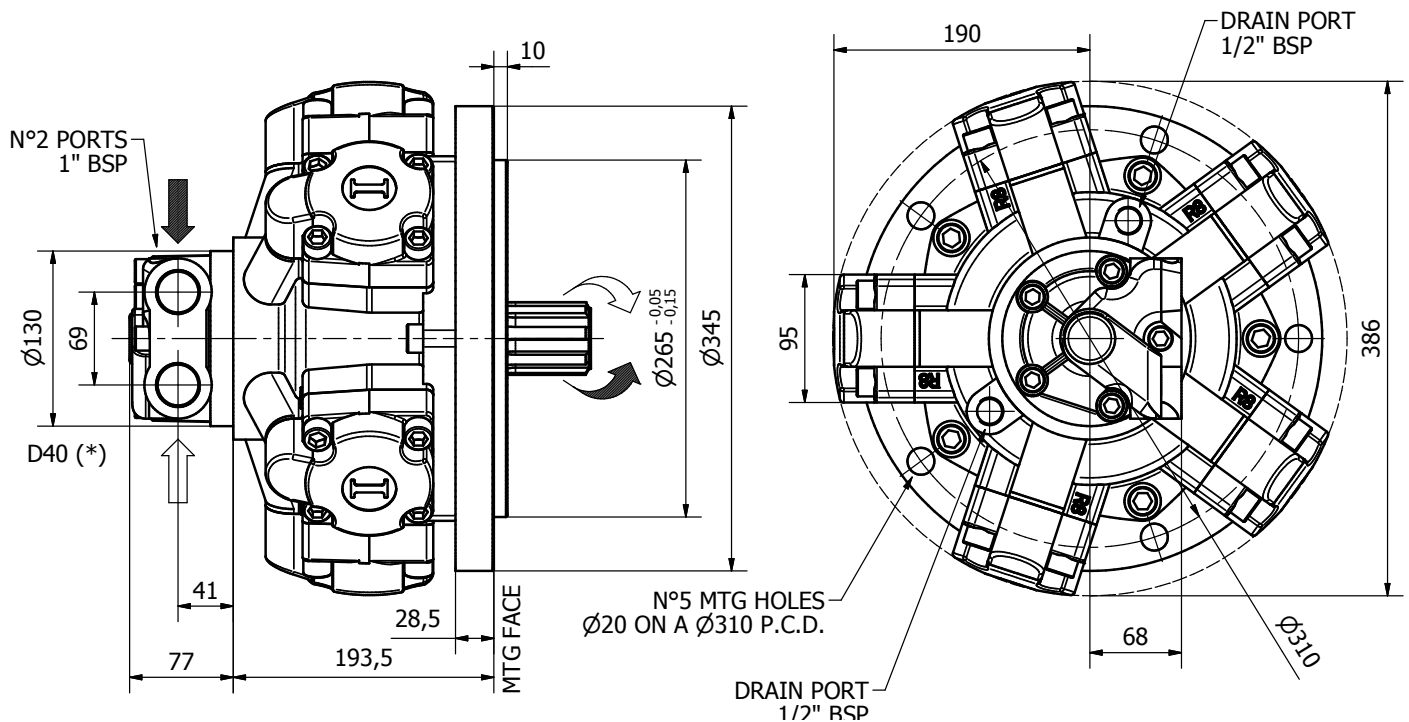

TECHNICAL DATA

		400	450	500	600	650	700
DISPLACEMENT	[cc]	397	452	491	594	660	707
SPECIFIC TORQUE	[Nm/bar]	6.3	7.2	7.8	9.4	10.5	11.2
MAX. CONT. PRESSURE	[bar]	270	270	270	270	250	250
HYDROSTATIC TEST PRESSURE	[bar]	420	420	420	420	420	420
MAX. CONT. SPEED	[rpm]	600	600	600	550	500	450
PEAK SPEED (***)	[rpm]	680	680	680	630	580	500
MAX. CONT. POWER (****)	[kW]	47	47	47	47	47	47
MAX. POWER	[kW]	70	70	70	70	70	70
MAX. CASE PRESSURE	[bar]	6	6	6	6	6	6
DRY WEIGHT	[kg]	68	68	68	68	68	68
TEMPERATURE RANGE (**)	[°C]	-30÷70	-30÷70	-30÷70	-30÷70	-30÷70	-30÷70

- (*) The standard distributor (D40) is shown. Please refer to distributors section (pag. 178-179) for different distributor interfaces.

- (**) Please refer to the hydraulic fluid recommendations (pag. 10-11).

- (***) Do not exceed maximum power.

- (****) For motor operation with a continuous duty cycle at maximum continuous power the flushing is usually required (see pag. 13). For more information please contact our technical department.

SHAFTS

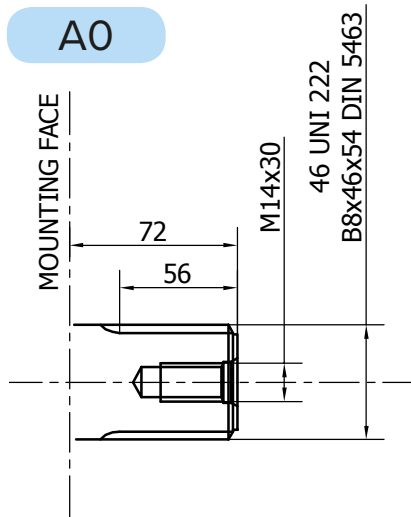

Available spline billet: SB5

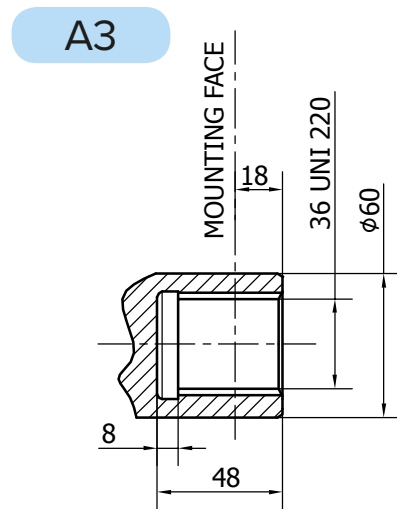

Available spline bar: B8078

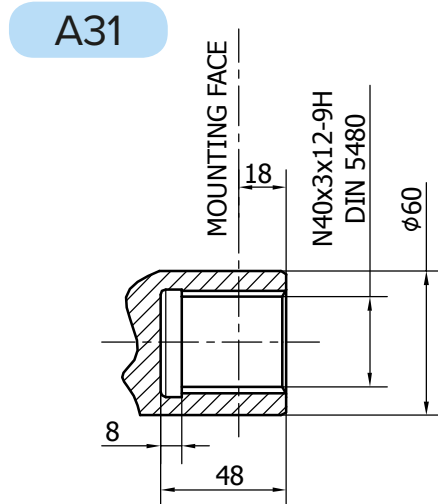

Available spline bar: B8076

R8M H3/S

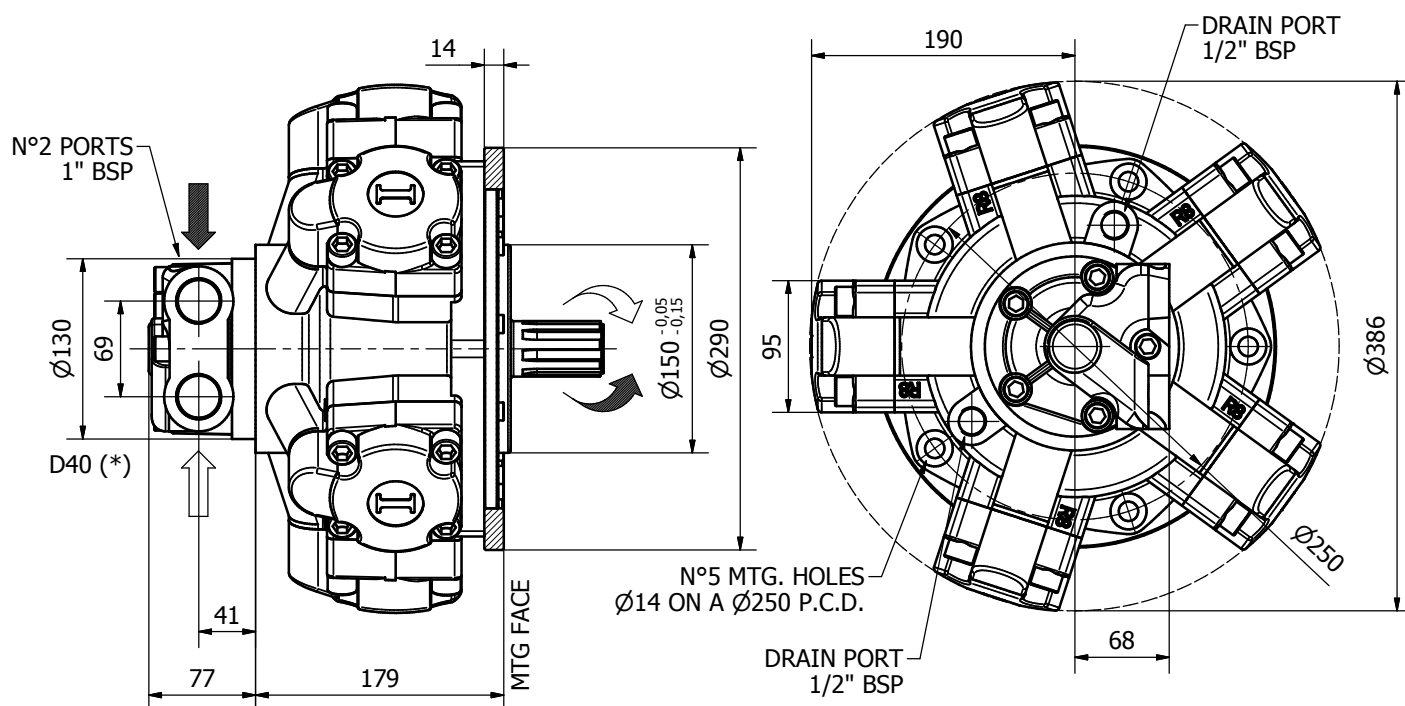

TECHNICAL DATA

		400	450	500	600	650	700
DISPLACEMENT	[cc]	397	452	491	594	660	707
SPECIFIC TORQUE	[Nm/bar]	6.3	7.2	7.8	9.4	10.5	11.2
MAX. CONT. PRESSURE	[bar]	270	270	270	270	250	250
HYDROSTATIC TEST PRESSURE	[bar]	420	420	420	420	420	420
MAX. CONT. SPEED	[rpm]	600	600	600	550	500	450
PEAK SPEED (***)	[rpm]	680	680	680	630	580	500
MAX. CONT. POWER (****)	[kW]	47	47	47	47	47	47
MAX. POWER	[kW]	70	70	70	70	70	70
MAX. CASE PRESSURE	[bar]	6	6	6	6	6	6
DRY WEIGHT	[kg]	68	68	68	68	68	68
TEMPERATURE RANGE (**)	[°C]	-30÷70	-30÷70	-30÷70	-30÷70	-30÷70	-30÷70

- (*) The standard distributor (D40) is shown. Please refer to distributors section (pag. 178-179) for different distributor interfaces.

- (**) Please refer to the hydraulic fluid recommendations (pag. 10-11).

- (***) Do not exceed maximum power.

- (****) For motor operation with a continuous duty cycle at maximum continuous power the flushing is usually required (see pag. 13). For more information please contact our technical department.

SHAFTS

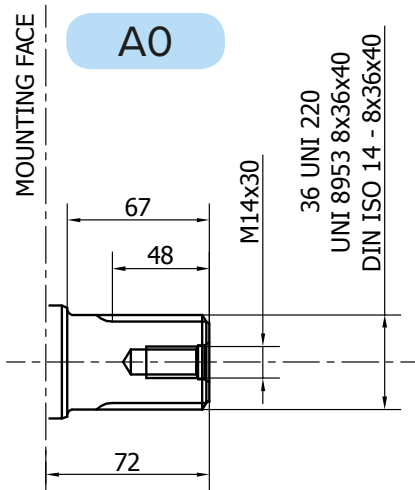

Available spline billet: SB3

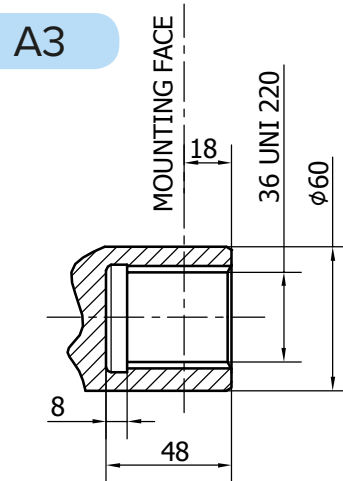

Available spline bar: B8078

A31

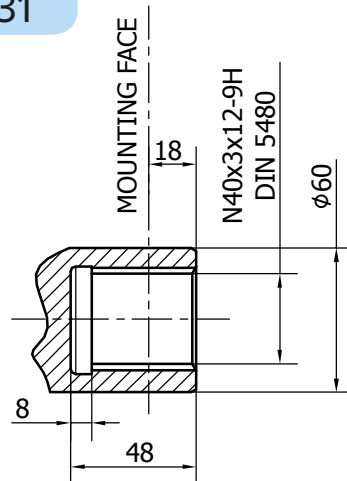

Available spline bar: B8076

R8M H3 - PERFORMANCE CURVES

R8M 350 H3

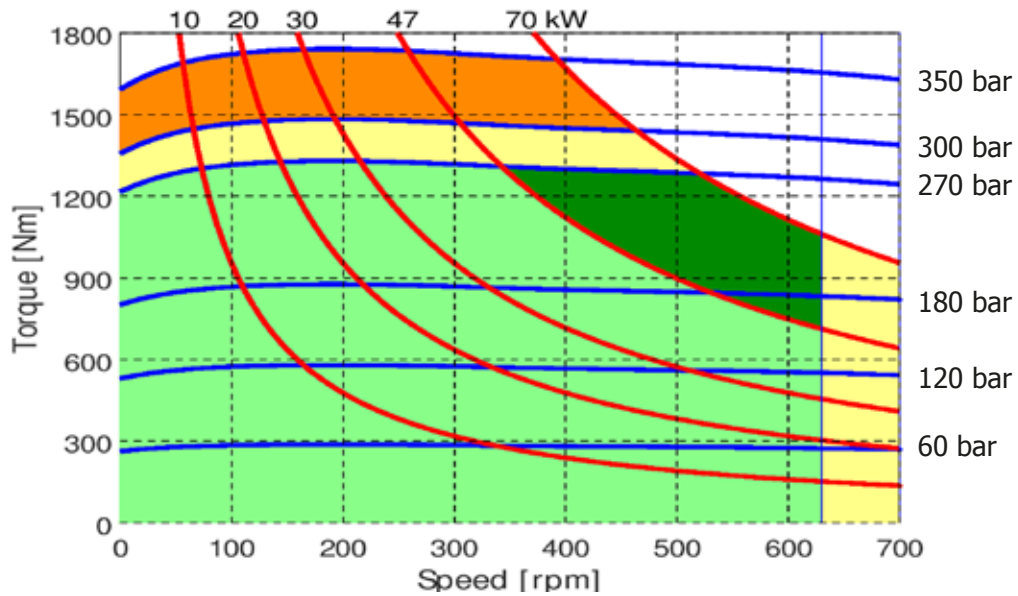

R8M 400 H3

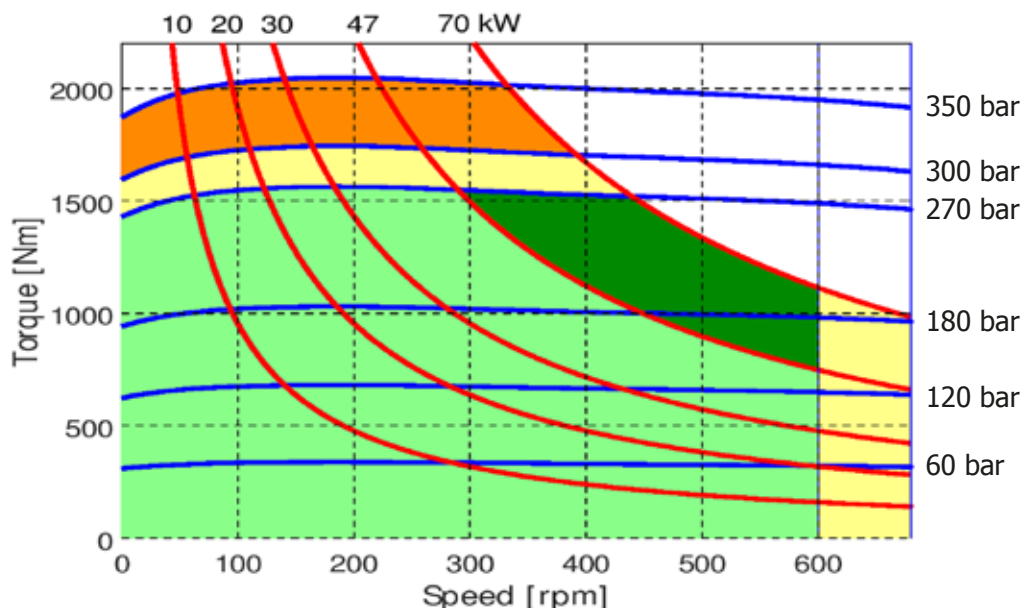

- Continuous operation
- Continuous operation with flushing or intermittent operation (see below for intermittent operation)
- Intermittent operation: permitted for a 15% of duty cycle, for 3 minutes maximum period
- Peak operation: permitted for very short periods (3-5 seconds every 10-15 minutes)

The above diagrams are referring to the hydraulic motor working with a fluid in ideal conditions (viscosity at 40 cSt). In case the working temperature increases and viscosity reach values under the recommended values (see hydraulic fluid recommendations) flushing must be performed or ISO oil grade must be changed. The working temperature must not overcome 70 °C.

R8M 450 H3

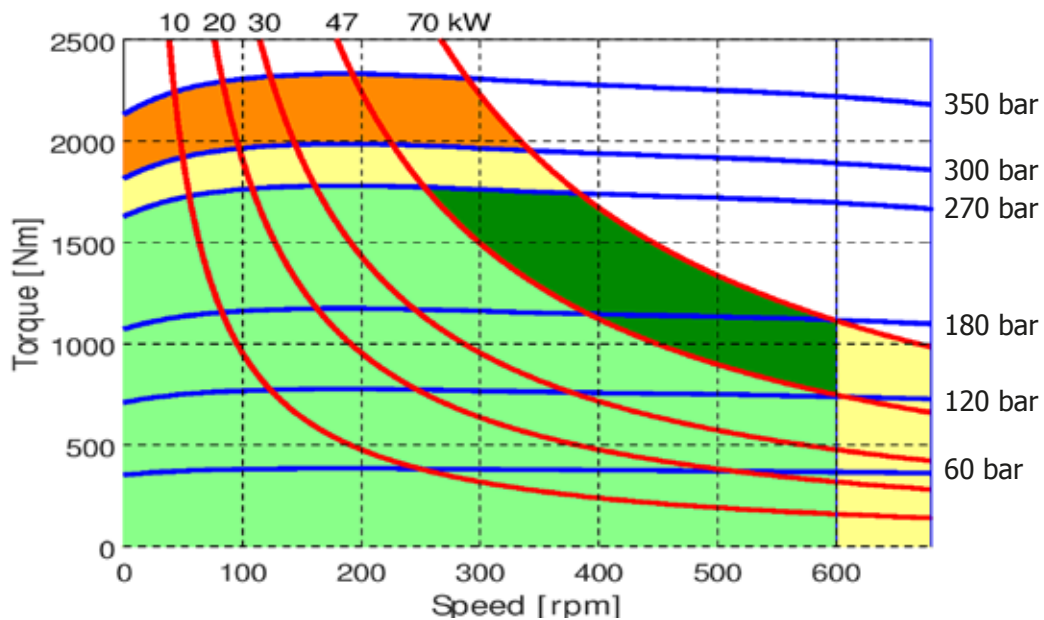

R8M 500 H3

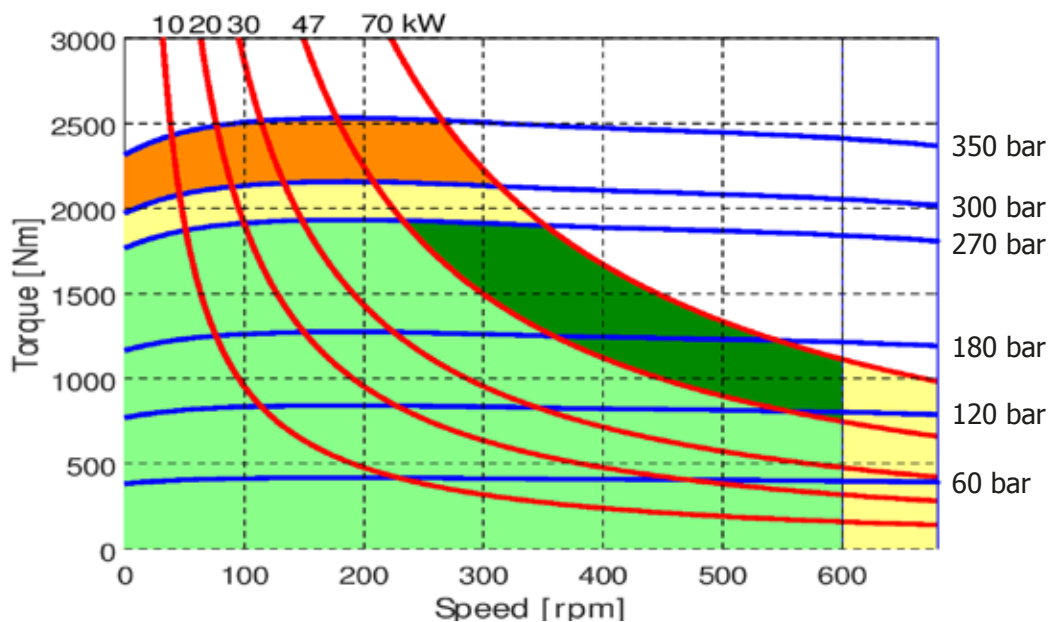

- Continuous operation
- Continuous operation with flushing or intermittent operation (see below for intermittent operation)
- Intermittent operation: permitted for a 15% of duty cycle, for 3 minutes maximum period
- Peak operation: permitted for very short periods (3-5 seconds every 10-15 minutes)

The above diagrams are referring to the hydraulic motor working with a fluid in ideal conditions (viscosity at 40 cSt). In case the working temperature increases and viscosity reach values under the recommended values (see hydraulic fluid recommendations) flushing must be performed or ISO oil grade must be changed. The working temperature must not overcome 70 °C.

R8M H3 - PERFORMANCE CURVES

R8M 600 H3

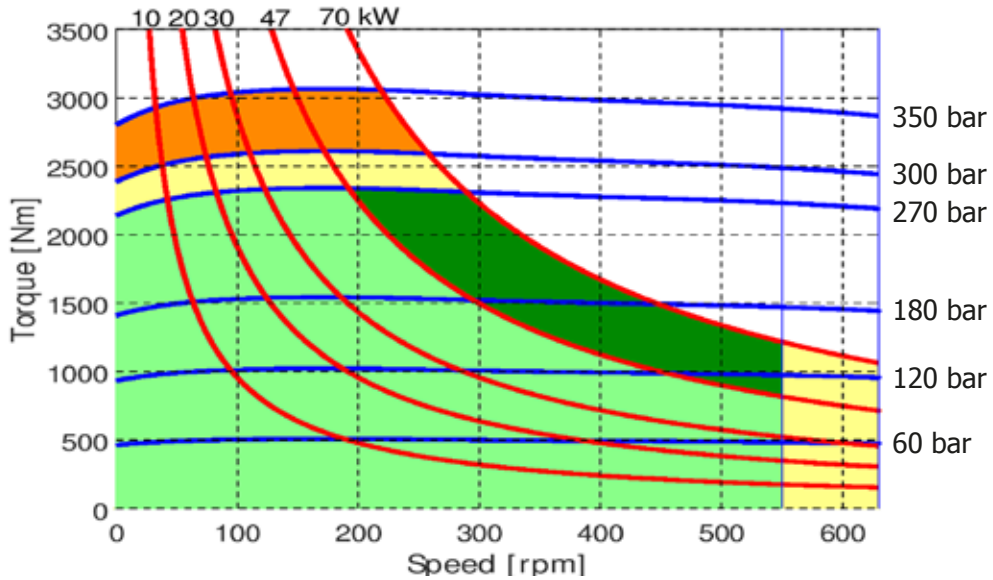

R8M 650 H3

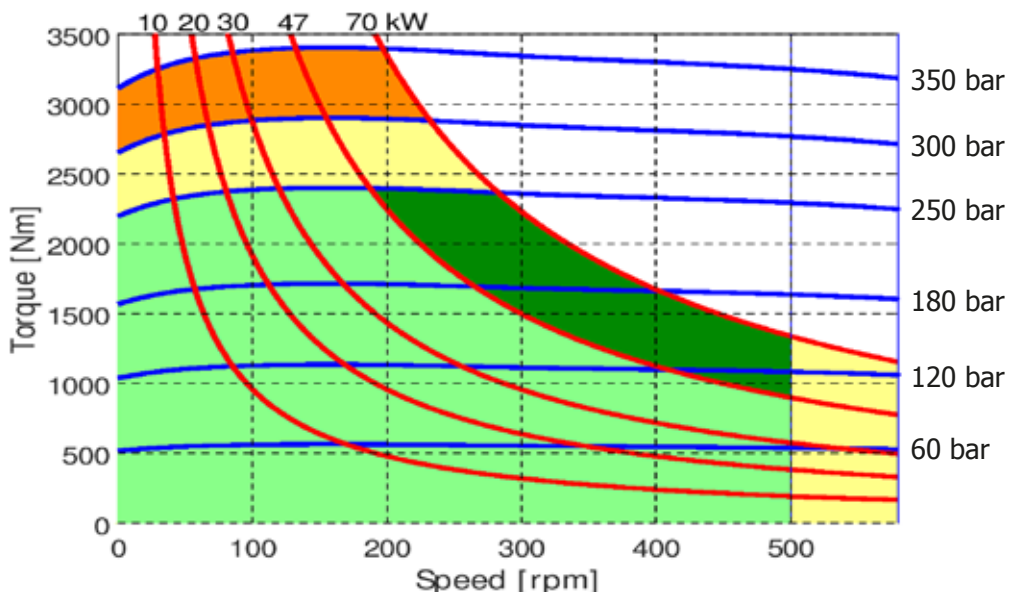

- Continuous operation
- Continuous operation with flushing or intermittent operation (see below for intermittent operation)
- Intermittent operation: permitted for a 15% of duty cycle, for 3 minutes maximum period
- Peak operation: permitted for very short periods (3-5 seconds every 10-15 minutes)

The above diagrams are referring to the hydraulic motor working with a fluid in ideal conditions (viscosity at 40 cSt). In case the working temperature increases and viscosity reach values under the recommended values (see hydraulic fluid recommendations) flushing must be performed or ISO oil grade must be changed. The working temperature must not overcome 70 °C.

R8M 700 H3

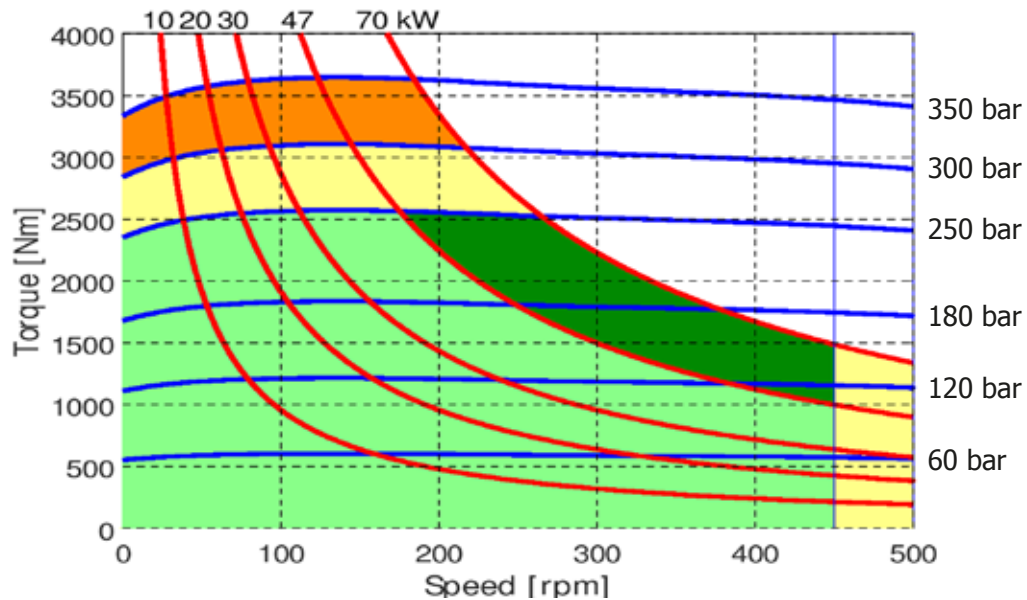

R8M 800 H3

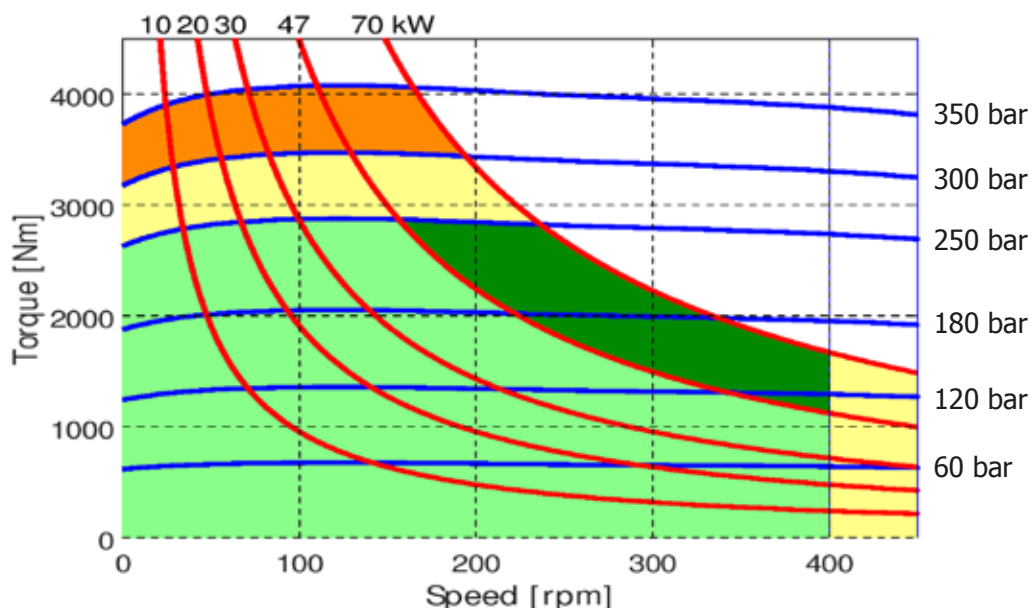

- Continuous operation
- Continuous operation with flushing or intermittent operation (see below for intermittent operation)
- Intermittent operation: permitted for a 15% of duty cycle, for 3 minutes maximum period
- Peak operation: permitted for very short periods (3-5 seconds every 10-15 minutes)

The above diagrams are referring to the hydraulic motor working with a fluid in ideal conditions (viscosity at 40 cSt). In case the working temperature increases and viscosity reach values under the recommended values (see hydraulic fluid recommendations) flushing must be performed or ISO oil grade must be changed. The working temperature must not overcome 70 °C.

R8M H3 - PERFORMANCE CURVES

BEARING LIFE

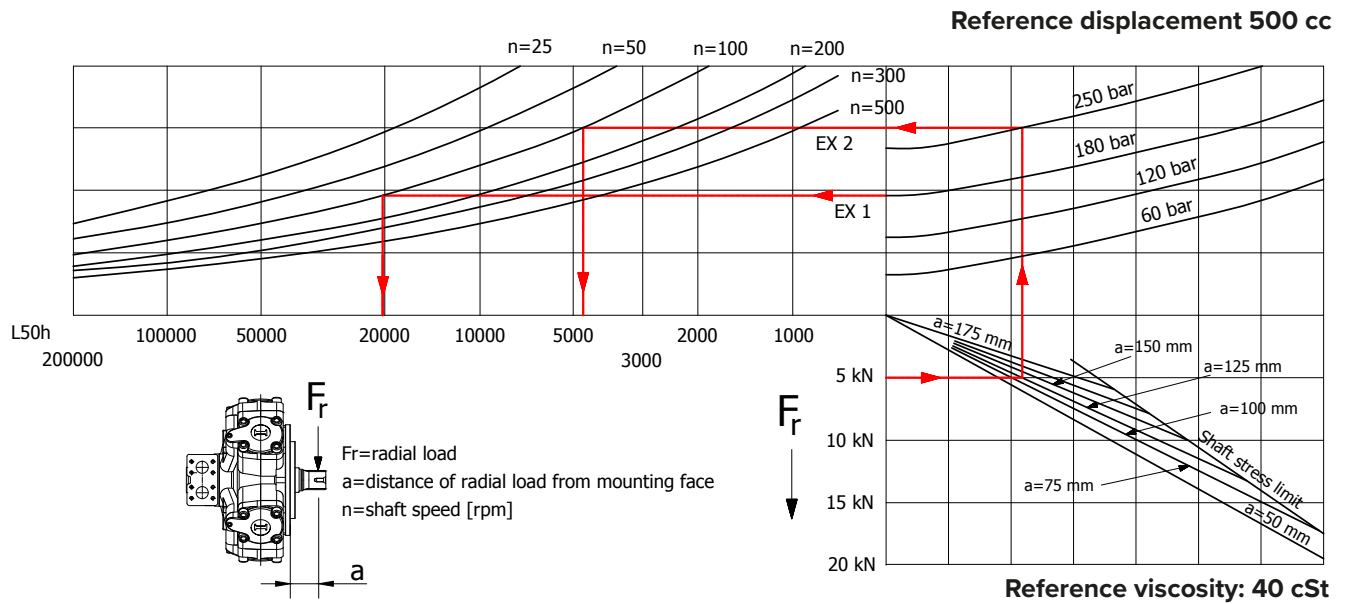

Example:

We suppose (EX1): $p=120$ [bar], $n=400$ [rpm]; we obtain an average lifetime of 53000 [h].

If we suppose (EX2): $F_r=9$ [kN], $a=75$ [mm], $n=100$ [rpm] and $p=180$ [bar] we obtain an average lifetime of 42000 [h].

The above data are referring to the R8M H3 series motors, displacement 500 cc.

R8M H3 - ORDERING CODE

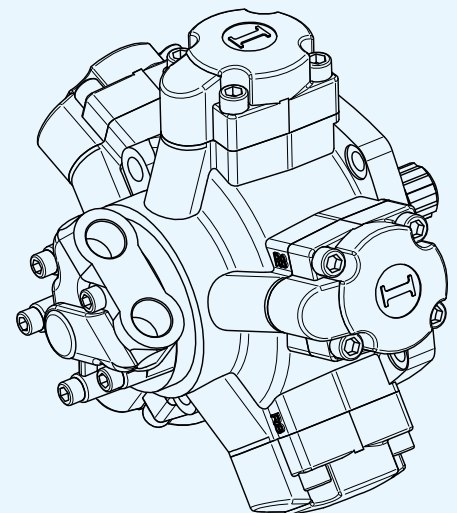
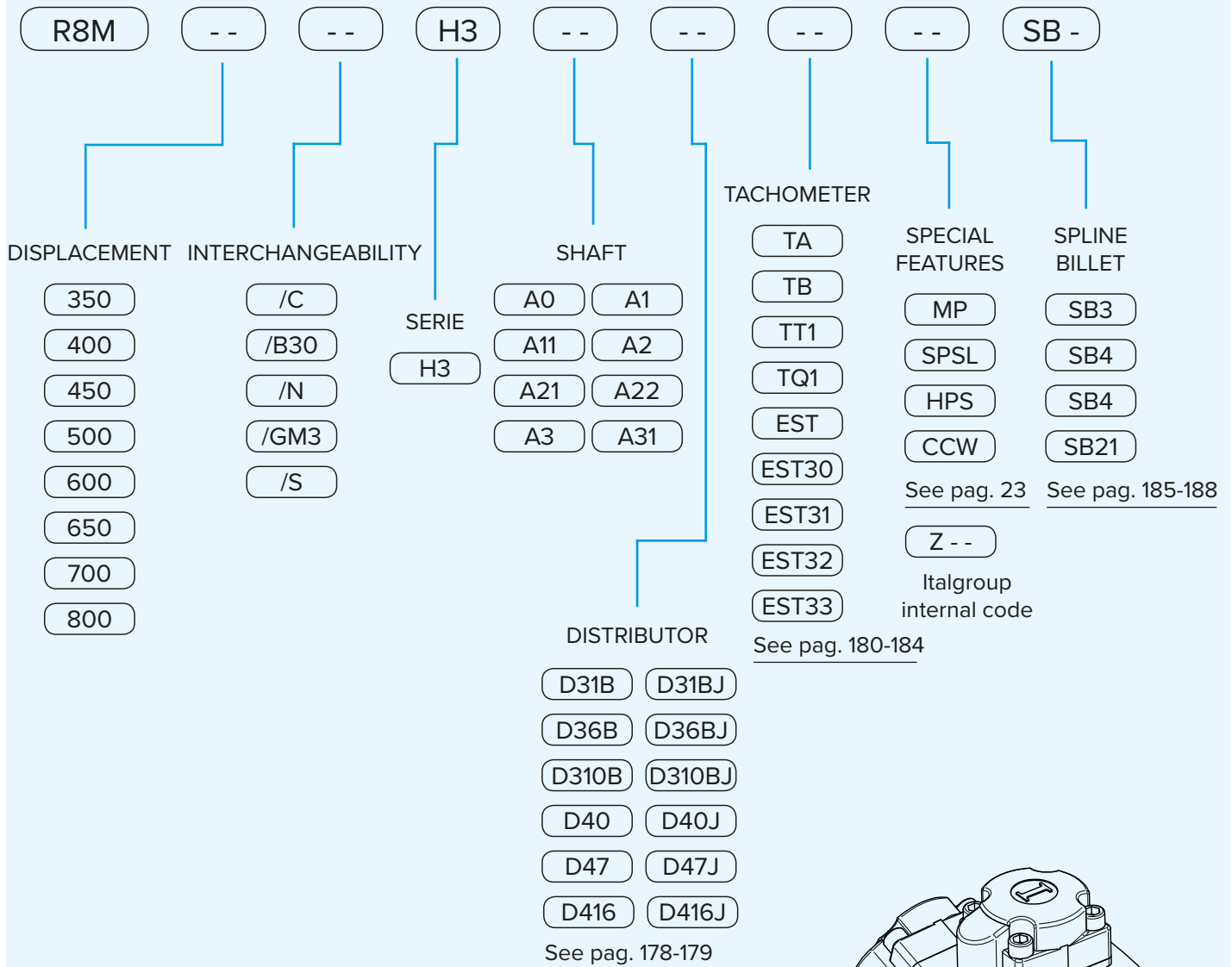

EXAMPLES:

R8M 600 H3 A2 D416
 R8M 450/C H3 A1 D40 CCW SB5
 R8M 400/GM3 H3 A0 D47

R 8 M H 4

R8M H4	Pag. 94 - 95
R8M H4/C	Pag. 96 - 97
R8M H3/B45	Pag. 98 - 99
R8M H4/GM4	Pag. 100 - 101
R8M H4/S	Pag. 102- 103
R8M H4 - PERFORMANCE CURVES	Pag. 104 - 109
R8M H4 - ORDERING CODE	Pag. 110

SHAFTS

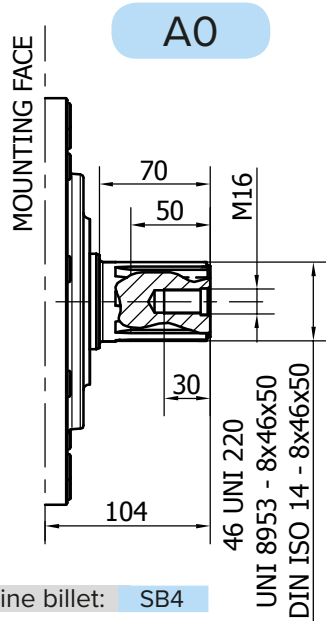

Available spline billet: SB4

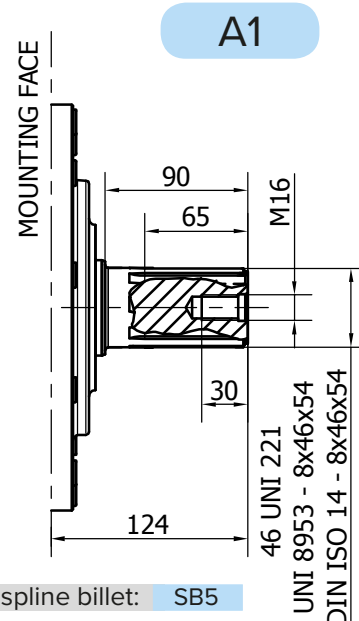

Available spline billet: SB5

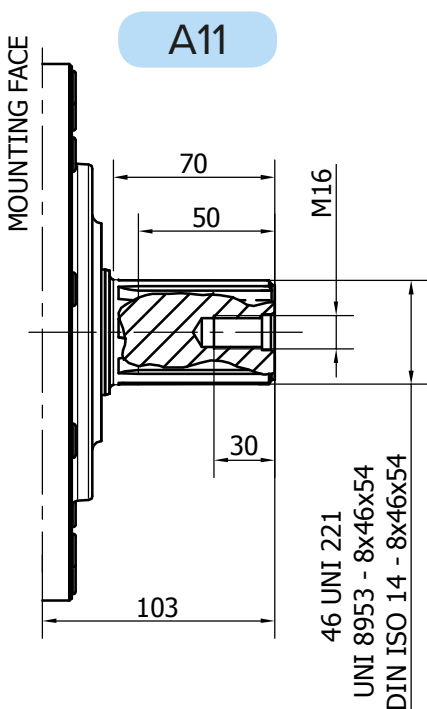

Available spline billet: SB5

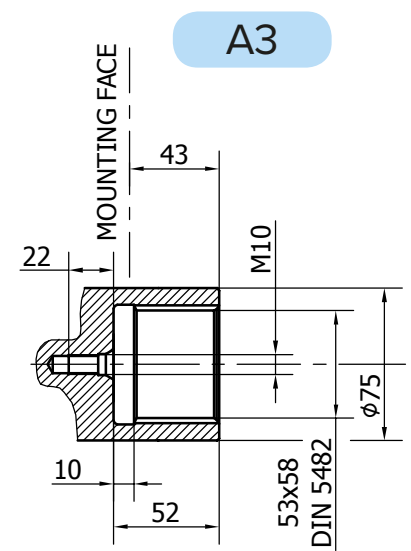
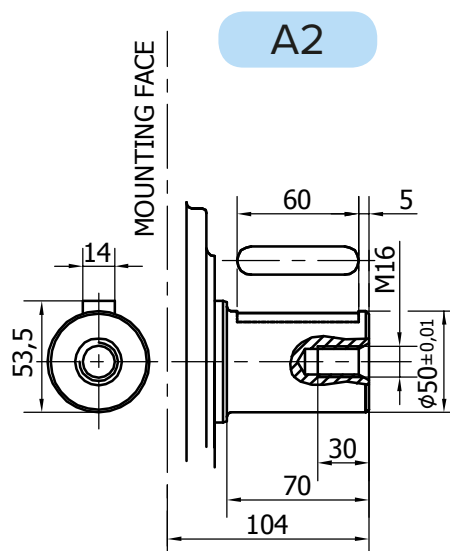

Available spline bar: B8079

NOT AVAILABLE FOR
850-1200-1400 cc

R8M H4/C

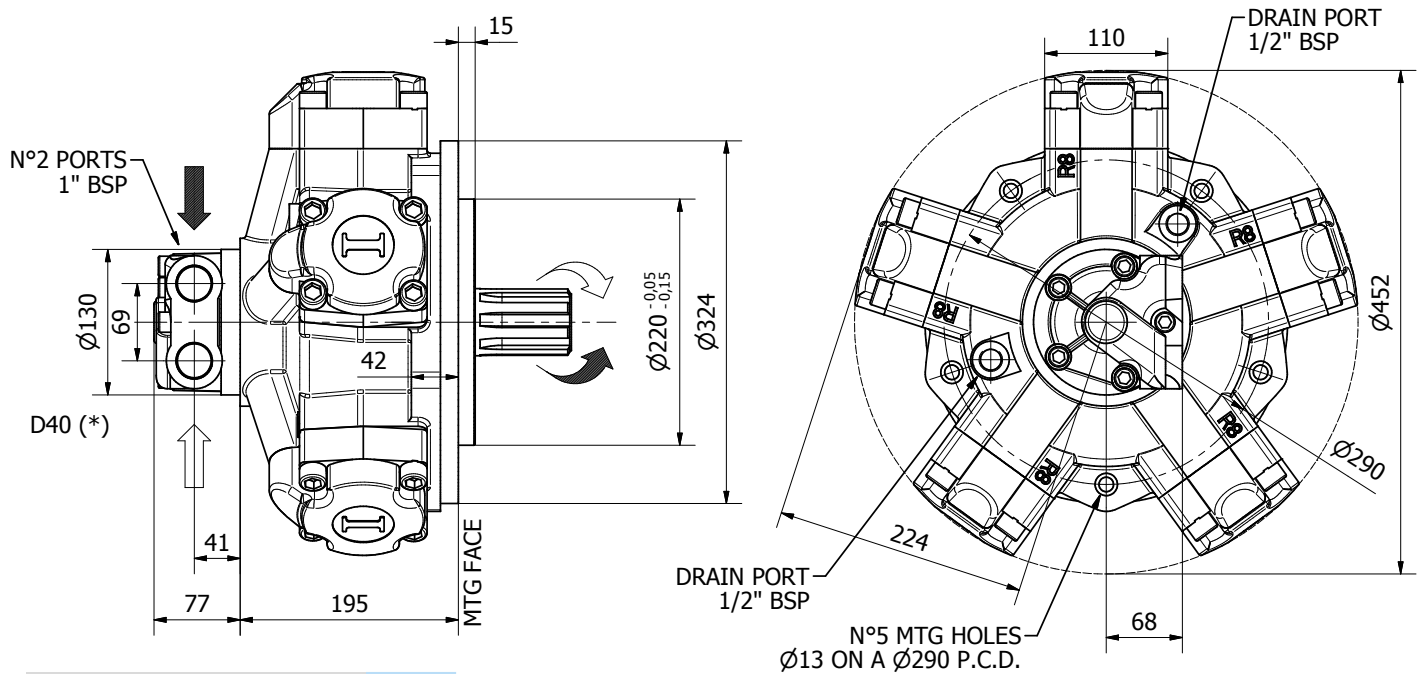

Available distributor flange: **FL2**

Refer to page 190-191
(distributor fitting D47)

TECHNICAL DATA

		700	800	900	1000	1100	1250
DISPLACEMENT	[cc]	714	792	904	992	1116	1247
SPECIFIC TORQUE	[Nm/bar]	11.4	12.6	14.4	15.8	17.8	19.8
MAX. CONT. PRESSURE	[bar]	270	270	270	270	260	250
HYDROSTATIC TEST PRESSURE	[bar]	420	420	420	420	420	420
MAX. CONT. SPEED	[rpm]	500	450	450	330	330	250
PEAK SPEED (***)	[rpm]	580	530	530	400	400	300
MAX. CONT. POWER (****)	[kW]	56	56	56	56	56	56
MAX. POWER	[kW]	82	82	82	82	82	82
MAX. CASE PRESSURE	[bar]	6	6	6	6	6	6
DRY WEIGHT	[kg]	92	92	92	92	92	92
TEMPERATURE RANGE (**)	[°C]	-30÷70	-30÷70	-30÷70	-30÷70	-30÷70	-30÷70

- (*) The standard distributor (D40) is shown. Please refer to distributors section (pag. 178-179) for different distributor interfaces.

- (**) Please refer to the hydraulic fluid recommendations (pag. 10-11).

- (***) Do not exceed maximum power.

- (****) For motor operation with a continuous duty cycle at maximum continuous power the flushing is usually required (see pag. 13). For more information please contact our technical department.

SHAFTS

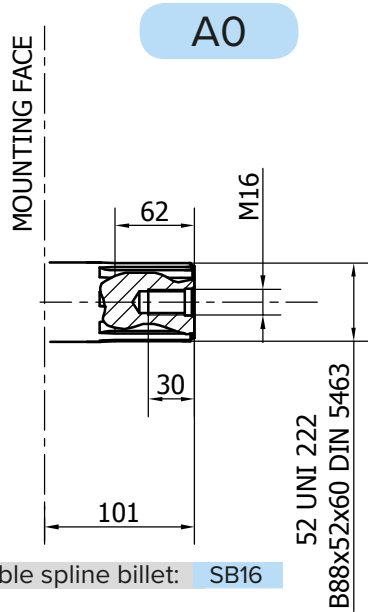

Available spline billet: SB16

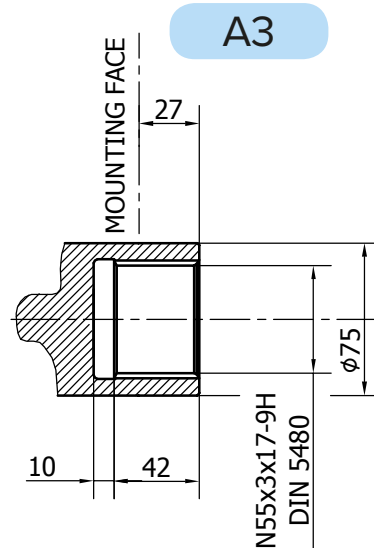
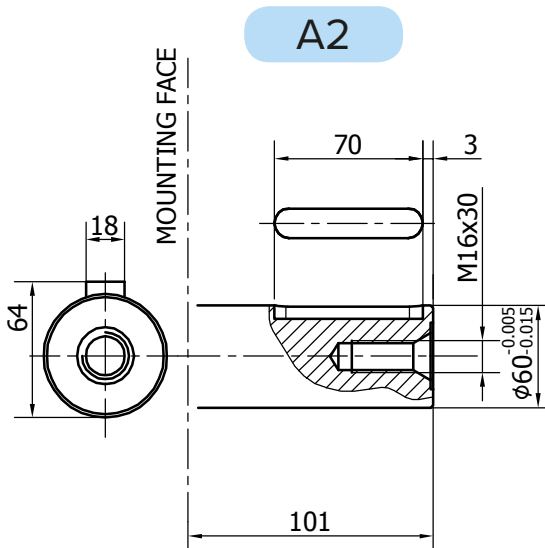
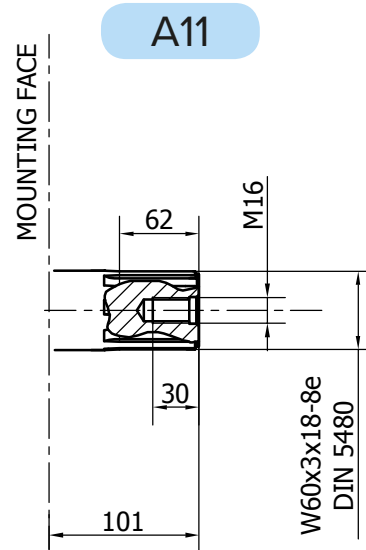

R8M H4/B45

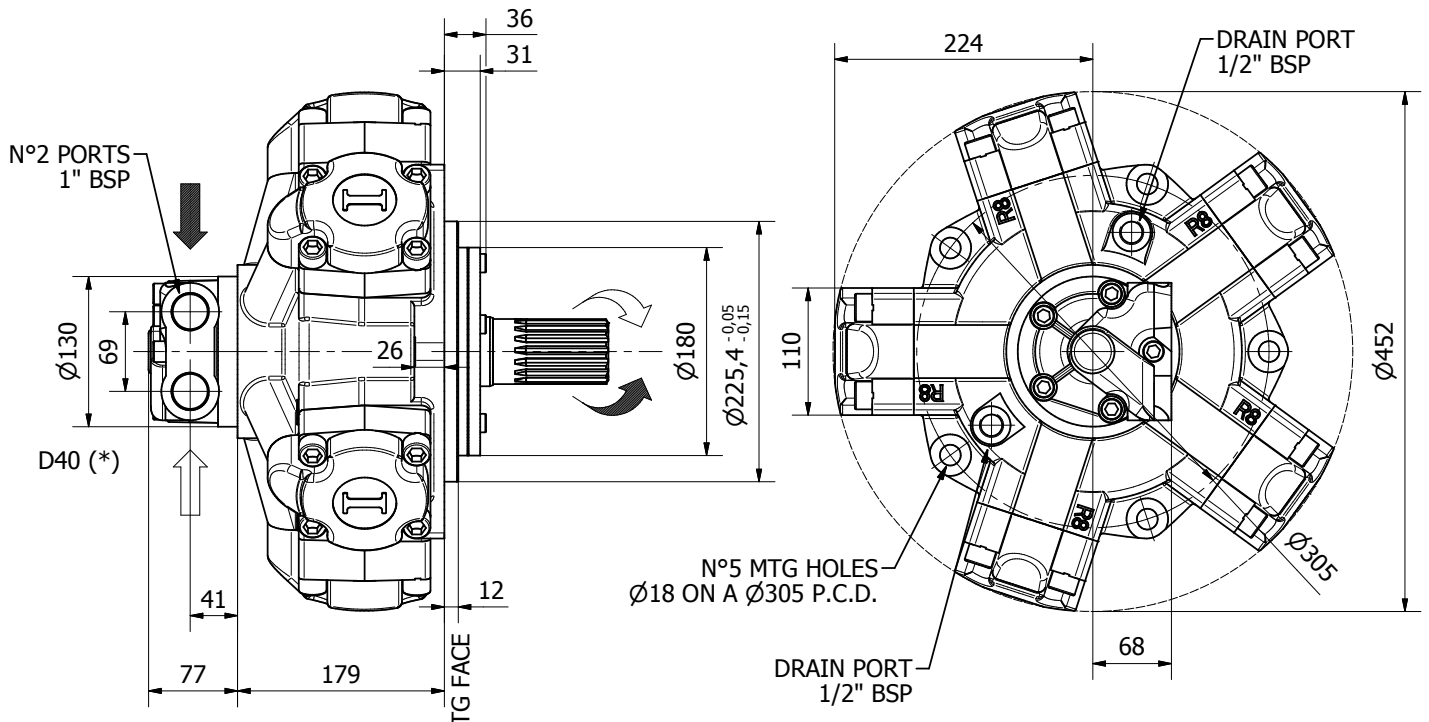

TECHNICAL DATA

		700	800	900	1000	1100	1250
DISPLACEMENT	[cc]	714	792	904	992	1116	1247
SPECIFIC TORQUE	[Nm/bar]	11.4	12.6	14.4	15.8	17.8	19.8
MAX. CONT. PRESSURE	[bar]	270	270	270	270	260	250
HYDROSTATIC TEST PRESSURE	[bar]	420	420	420	420	420	420
MAX. CONT. SPEED	[rpm]	500	450	450	330	330	250
PEAK SPEED (***)	[rpm]	580	530	530	400	400	300
MAX. CONT. POWER (****)	[kW]	56	56	56	56	56	56
MAX. POWER	[kW]	82	82	82	82	82	82
MAX. CASE PRESSURE	[bar]	6	6	6	6	6	6
DRY WEIGHT	[kg]	92	92	92	92	92	92
TEMPERATURE RANGE (**)	[°C]	-30÷70	-30÷70	-30÷70	-30÷70	-30÷70	-30÷70

- (*) The standard distributor (D40) is shown. Please refer to distributors section (pag. 178-179) for different distributor interfaces.

- (**) Please refer to the hydraulic fluid recommendations (pag. 10-11).

- (***) Do not exceed maximum power.

- (****) For motor operation with a continuous duty cycle at maximum continuous power the flushing is usually required (see pag. 13). For more information please contact our technical department.

SHAFTS

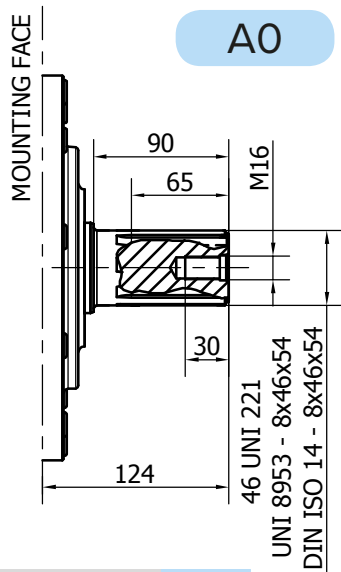

Available spline billet: SB5

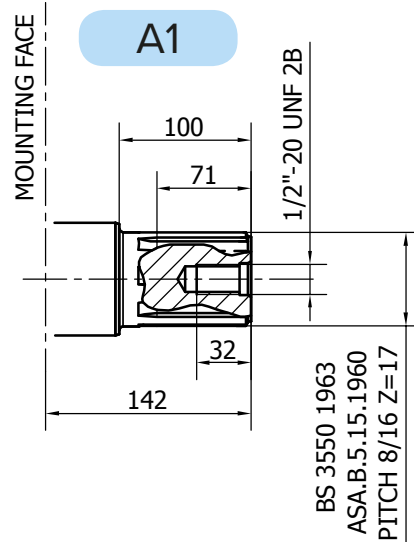

Available spline billet: SB21

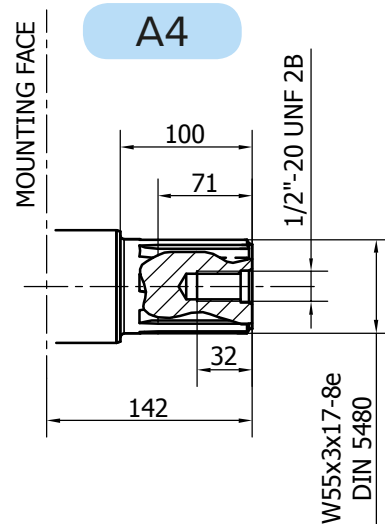
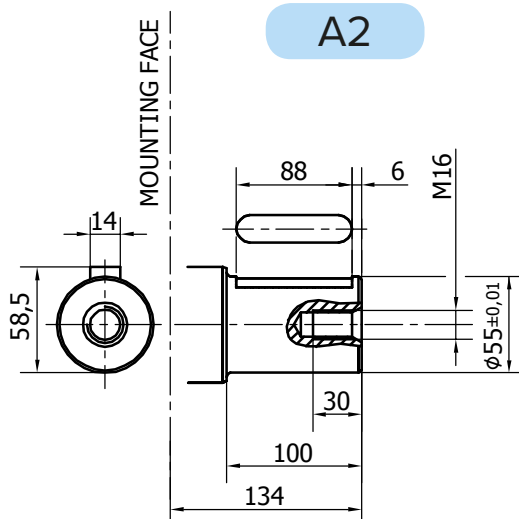

Available spline billet: SB30

R8M H4/GM4

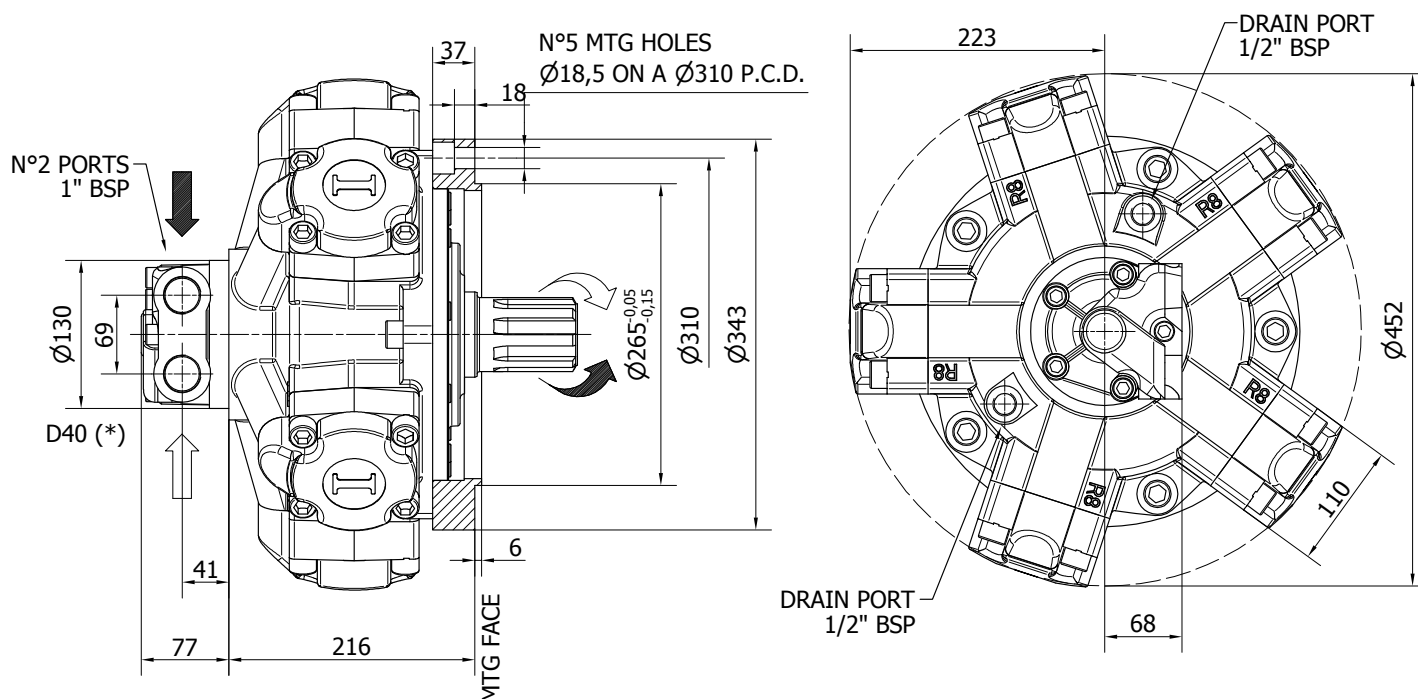

TECHNICAL DATA

		700	800	900	1000	1100	1250
DISPLACEMENT	[cc]	714	792	904	992	1116	1247
SPECIFIC TORQUE	[Nm/bar]	11.4	12.6	14.4	15.8	17.8	19.8
MAX. CONT. PRESSURE	[bar]	270	270	270	270	260	250
HYDROSTATIC TEST PRESSURE	[bar]	420	420	420	420	420	420
MAX. CONT. SPEED	[rpm]	500	450	450	330	330	250
PEAK SPEED (***)	[rpm]	580	530	530	400	400	300
MAX. CONT. POWER (****)	[kW]	56	56	56	56	56	56
MAX. POWER	[kW]	82	82	82	82	82	82
MAX. CASE PRESSURE	[bar]	6	6	6	6	6	6
DRY WEIGHT	[kg]	92	92	92	92	92	92
TEMPERATURE RANGE (**)	[°C]	-30÷70	-30÷70	-30÷70	-30÷70	-30÷70	-30÷70

- (*) The standard distributor (D40) is shown. Please refer to distributors section (pag. 178-179) for different distributor interfaces.

- (**) Please refer to the hydraulic fluid recommendations (pag. 10-11).

- (***) Do not exceed maximum power.

- (****) For motor operation with a continuous duty cycle at maximum continuous power the flushing is usually required (see pag. 13). For more information please contact our technical department.

SHAFTS

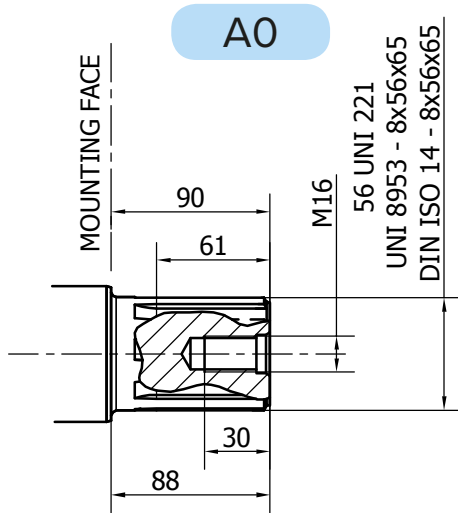

Available spline billet: SB17

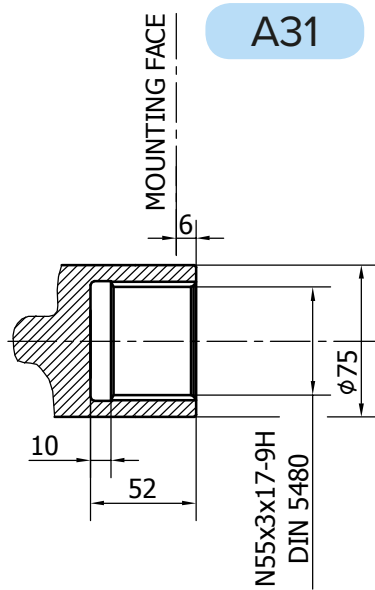
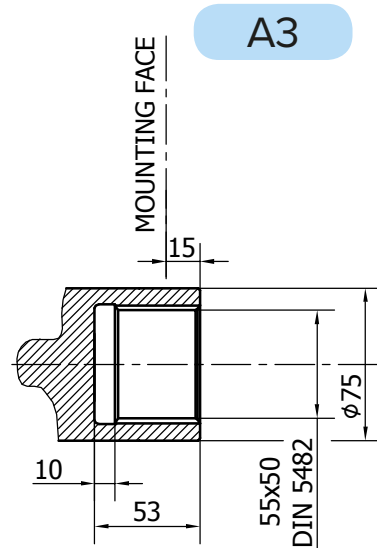

R8M H4/S

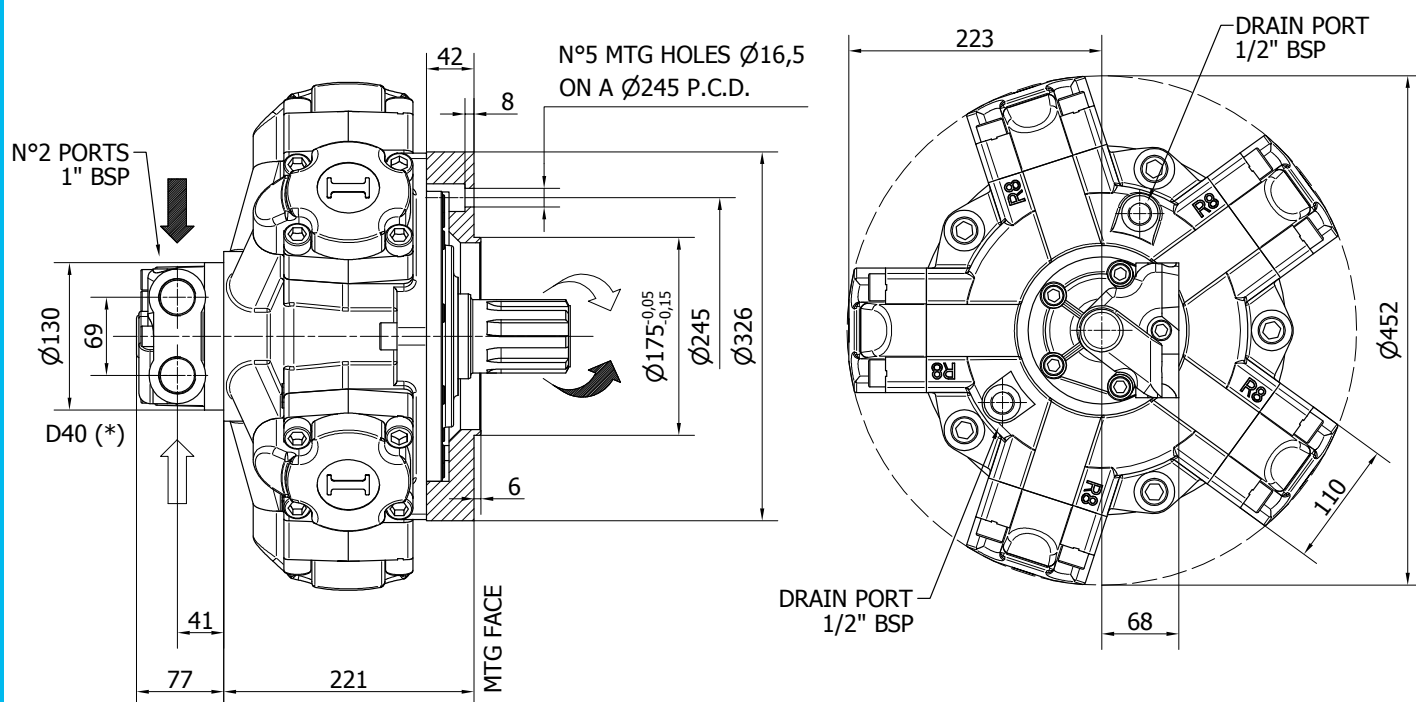

TECHNICAL DATA

		700	800	900	1000	1100	1250
DISPLACEMENT	[cc]	714	792	904	992	1116	1247
SPECIFIC TORQUE	[Nm/bar]	11.4	12.6	14.4	15.8	17.8	19.8
MAX. CONT. PRESSURE	[bar]	270	270	270	270	260	250
HYDROSTATIC TEST PRESSURE	[bar]	420	420	420	420	420	420
MAX. CONT. SPEED	[rpm]	500	450	450	330	330	250
PEAK SPEED (***)	[rpm]	580	530	530	400	400	300
MAX. CONT. POWER (****)	[kW]	56	56	56	56	56	56
MAX. POWER	[kW]	82	82	82	82	82	82
MAX. CASE PRESSURE	[bar]	6	6	6	6	6	6
DRY WEIGHT	[kg]	92	92	92	92	92	92
TEMPERATURE RANGE (**)	[°C]	-30÷70	-30÷70	-30÷70	-30÷70	-30÷70	-30÷70

- (*) The standard distributor (D40) is shown. Please refer to distributors section (pag. 178-179) for different distributor interfaces.

- (**) Please refer to the hydraulic fluid recommendations (pag. 10-11).

- (***) Do not exceed maximum power.

- (****) For motor operation with a continuous duty cycle at maximum continuous power the flushing is usually required (see pag. 13). For more information please contact our technical department.

SHAFTS

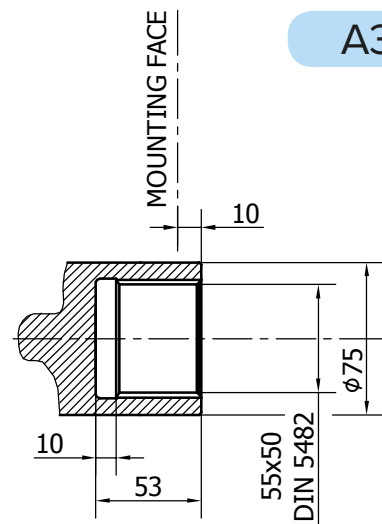
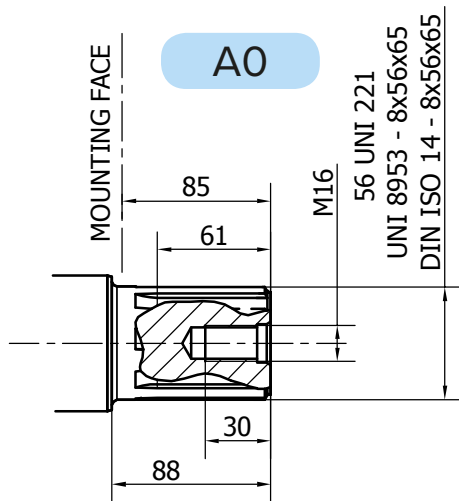

Available spline billet: SB17

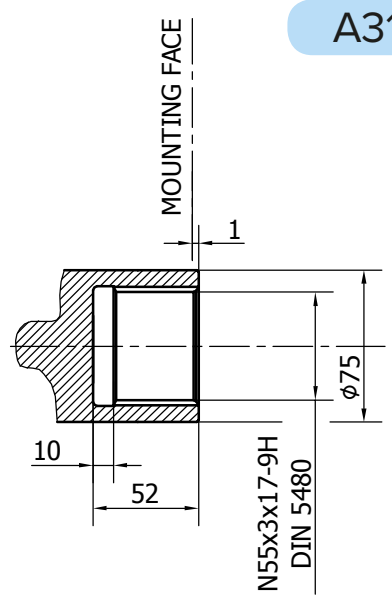

R8M H4 - PERFORMANCE CURVES

R8M 700 H4

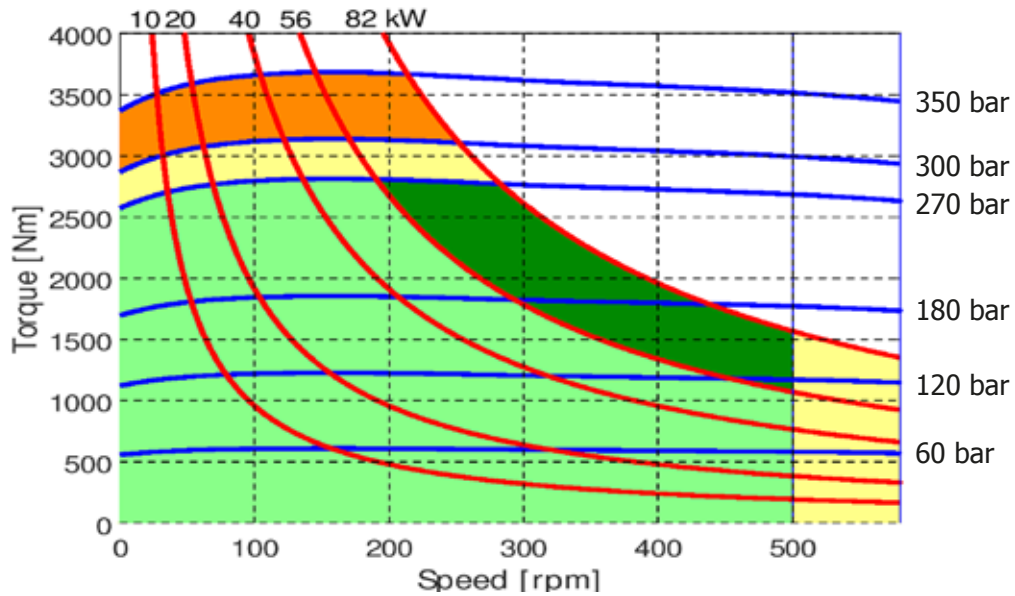

R8M 800 H4

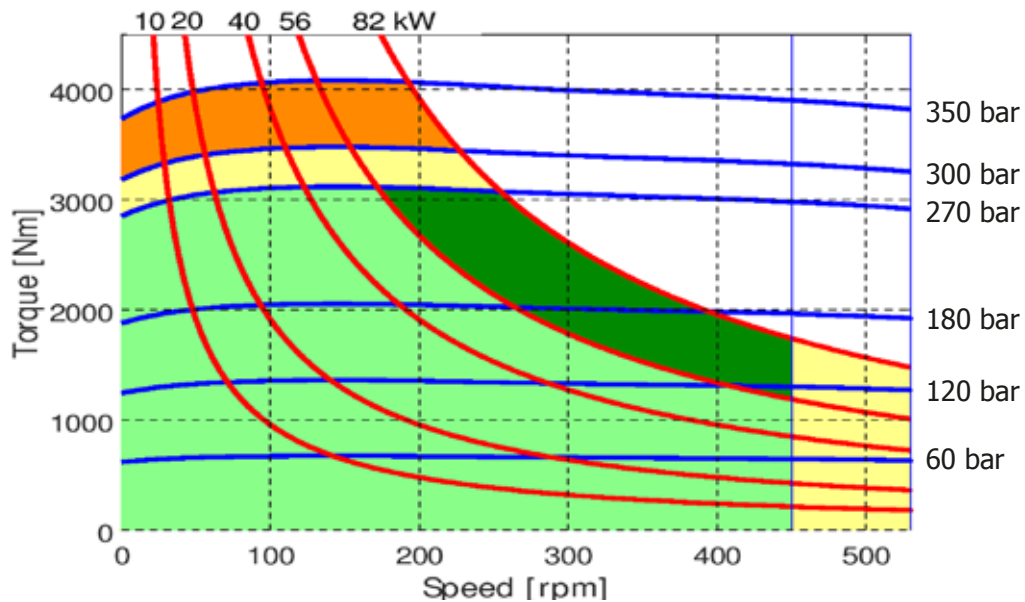

- Continuous operation
- Continuous operation with flushing or intermittent operation (see below for intermittent operation)
- Intermittent operation: permitted for a 15% of duty cycle, for 3 minutes maximum period
- Peak operation: permitted for very short periods (3-5 seconds every 10-15 minutes)

The above diagrams are referring to the hydraulic motor working with a fluid in ideal conditions (viscosity at 40 cSt). In case the working temperature increases and viscosity reach values under the recommended values (see hydraulic fluid recommendations) flushing must be performed or ISO oil grade must be changed. The working temperature must not overcome 70 °C.

SHAFTS

R8M 850 H4

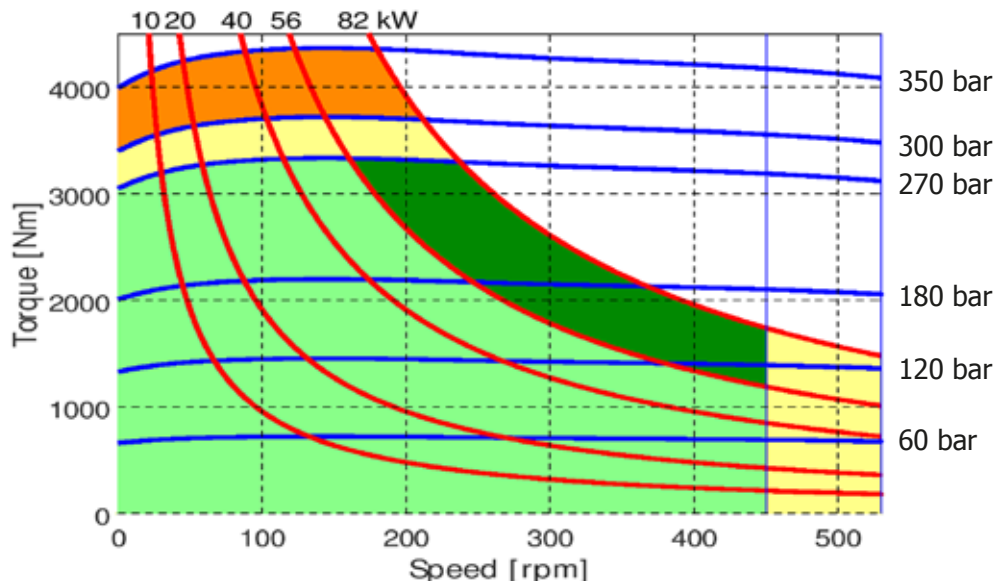

R8M 900 H4

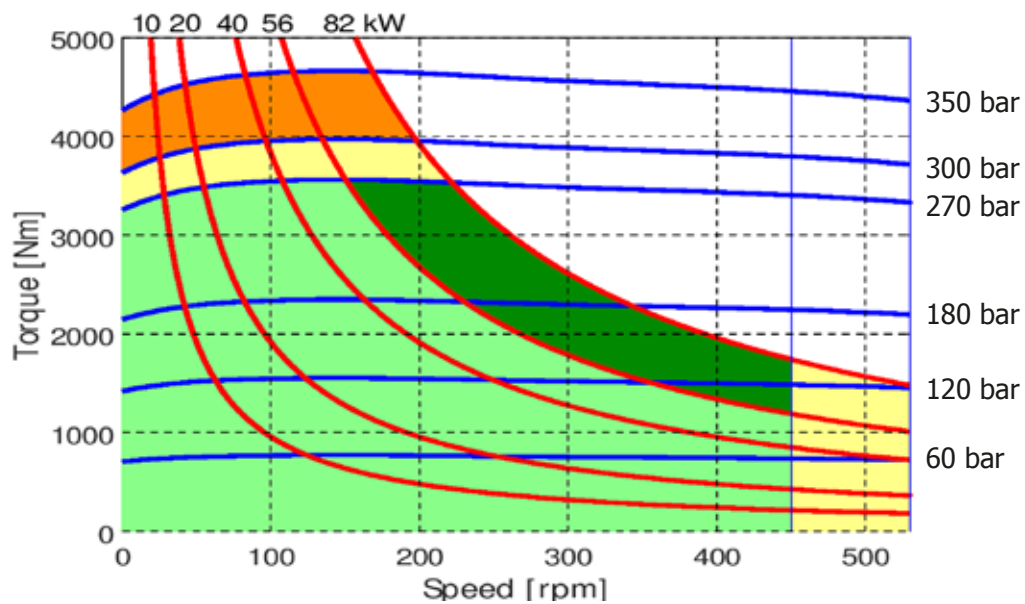

- Continuous operation
- Continuous operation with flushing or intermittent operation (see below for intermittent operation)
- Intermittent operation: permitted for a 15% of duty cycle, for 3 minutes maximum period
- Peak operation: permitted for very short periods (3-5 seconds every 10-15 minutes)

The above diagrams are referring to the hydraulic motor working with a fluid in ideal conditions (viscosity at 40 cSt). In case the working temperature increases and viscosity reach values under the recommended values (see hydraulic fluid recommendations) flushing must be performed or ISO oil grade must be changed. The working temperature must not overcome 70 °C.

R8M H4 - PERFORMANCE CURVES

R8M 1000 H4

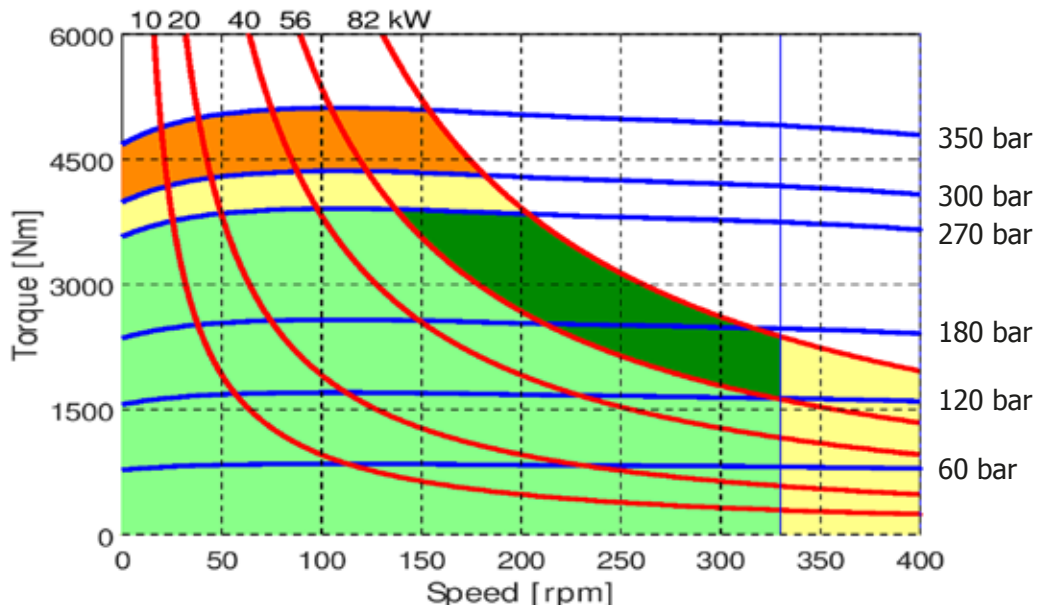

R8M 1100 H4

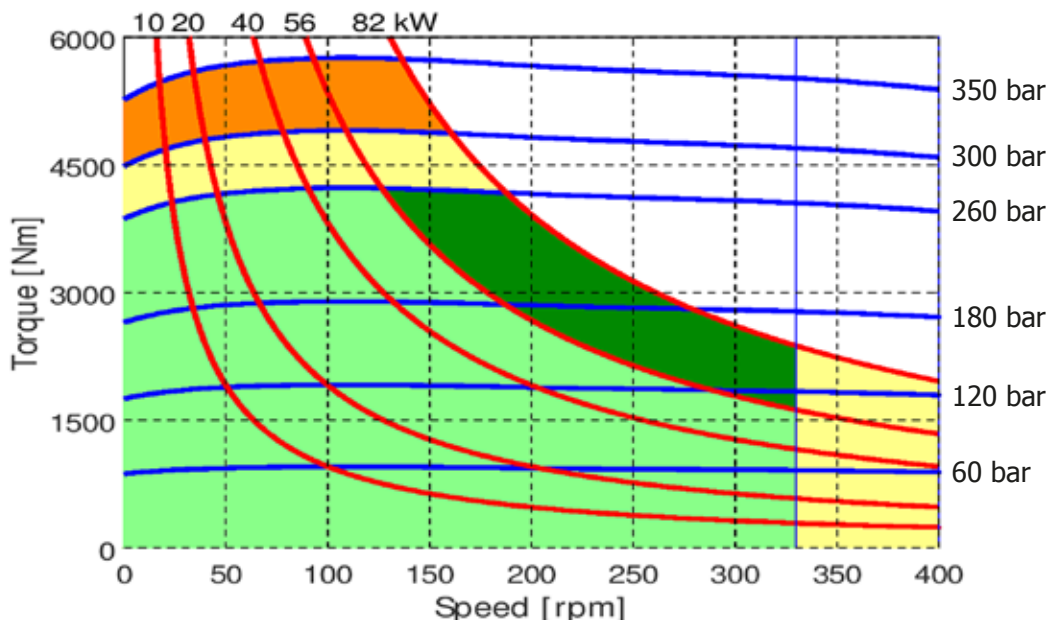

- Continuous operation
- Continuous operation with flushing or intermittent operation (see below for intermittent operation)
- Intermittent operation: permitted for a 15% of duty cycle, for 3 minutes maximum period
- Peak operation: permitted for very short periods (3-5 seconds every 10-15 minutes)

The above diagrams are referring to the hydraulic motor working with a fluid in ideal conditions (viscosity at 40 cSt). In case the working temperature increases and viscosity reach values under the recommended values (see hydraulic fluid recommendations) flushing must be performed or ISO oil grade must be changed. The working temperature must not overcome 70 °C.

R8M 1200 H4

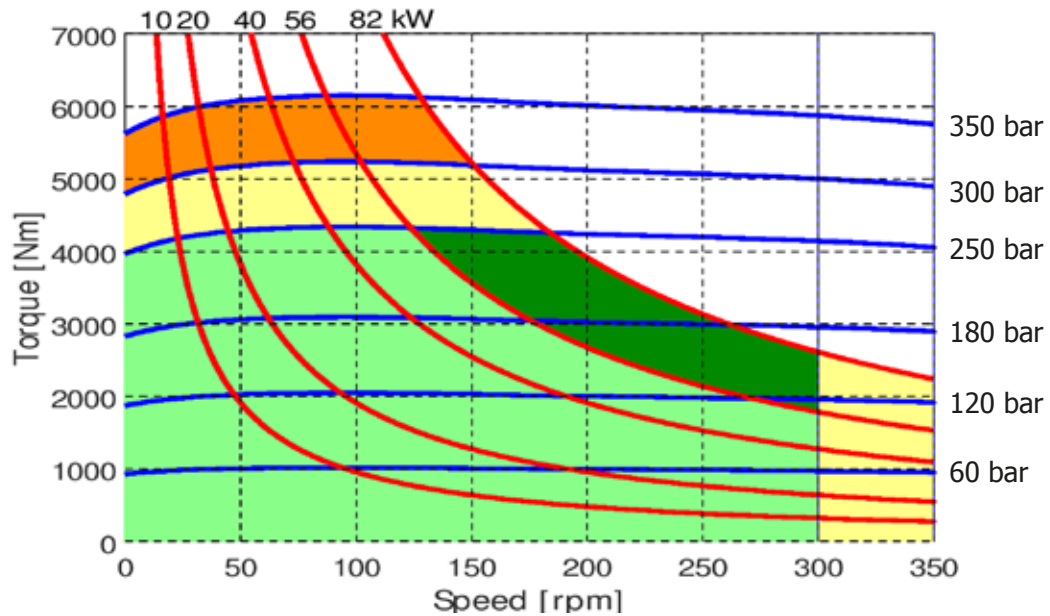

R8M 1250 H4

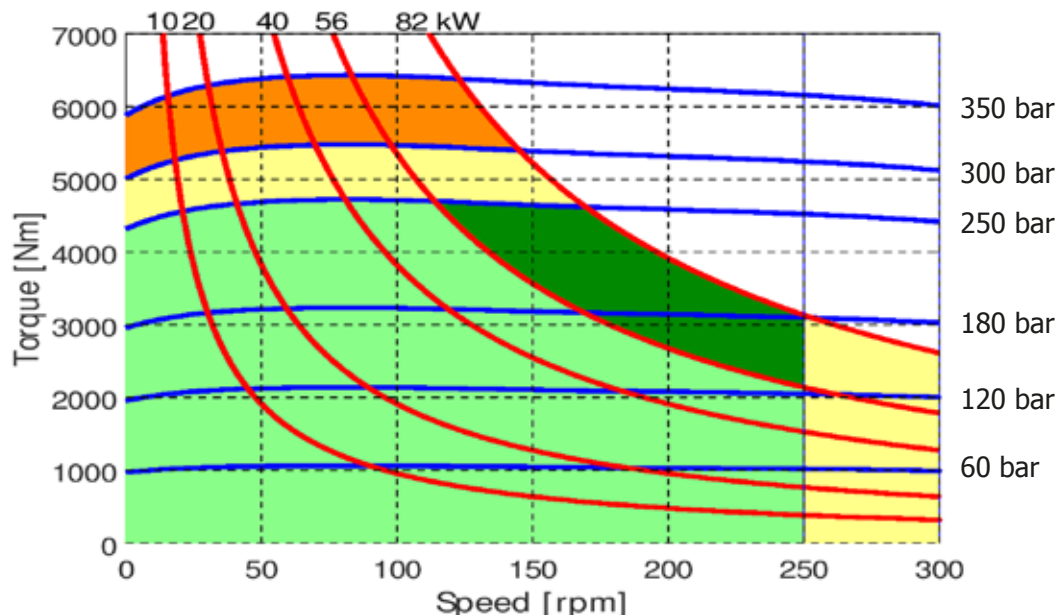

- Continuous operation
- Continuous operation with flushing or intermittent operation (see below for intermittent operation)
- Intermittent operation: permitted for a 15% of duty cycle, for 3 minutes maximum period
- Peak operation: permitted for very short periods (3-5 seconds every 10-15 minutes)

The above diagrams are referring to the hydraulic motor working with a fluid in ideal conditions (viscosity at 40 cSt). In case the working temperature increases and viscosity reach values under the recommended values (see hydraulic fluid recommendations) flushing must be performed or ISO oil grade must be changed. The working temperature must not overcome 70 °C.

R8M H4 - PERFORMANCE CURVES

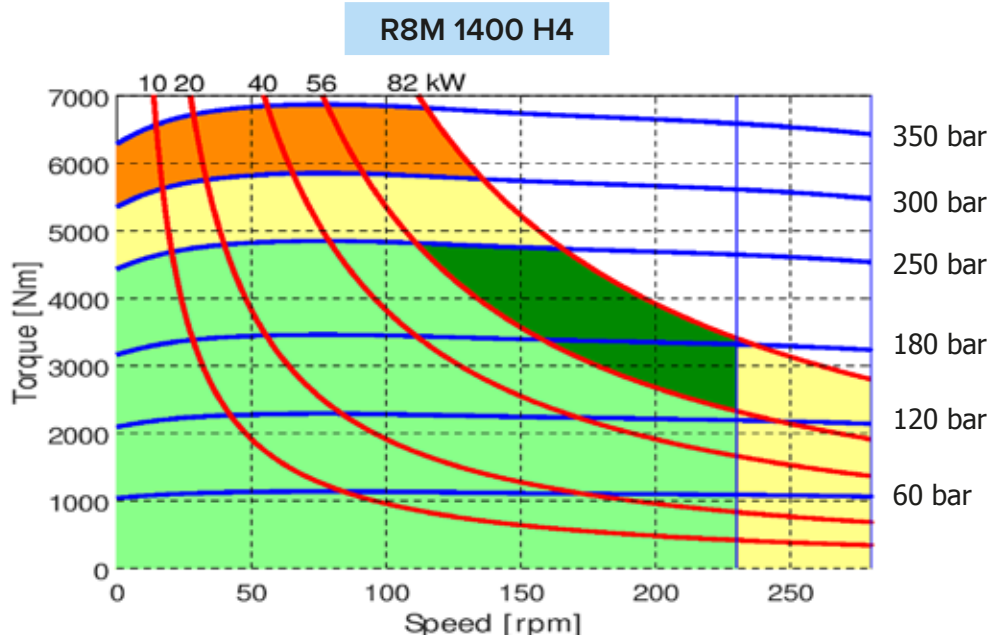

- Continuous operation
- Continuous operation with flushing or intermittent operation (see below for intermittent operation)
- Intermittent operation: permitted for a 15% of duty cycle, for 3 minutes maximum period
- Peak operation: permitted for very short periods (3-5 seconds every 10-15 minutes)

The above diagrams are referring to the hydraulic motor working with a fluid in ideal conditions (viscosity at 40 cSt). In case the working temperature increases and viscosity reach values under the recommended values (see hydraulic fluid recommendations) flushing must be performed or ISO oil grade must be changed. The working temperature must not overcome 70 °C.

BEARING LIFE

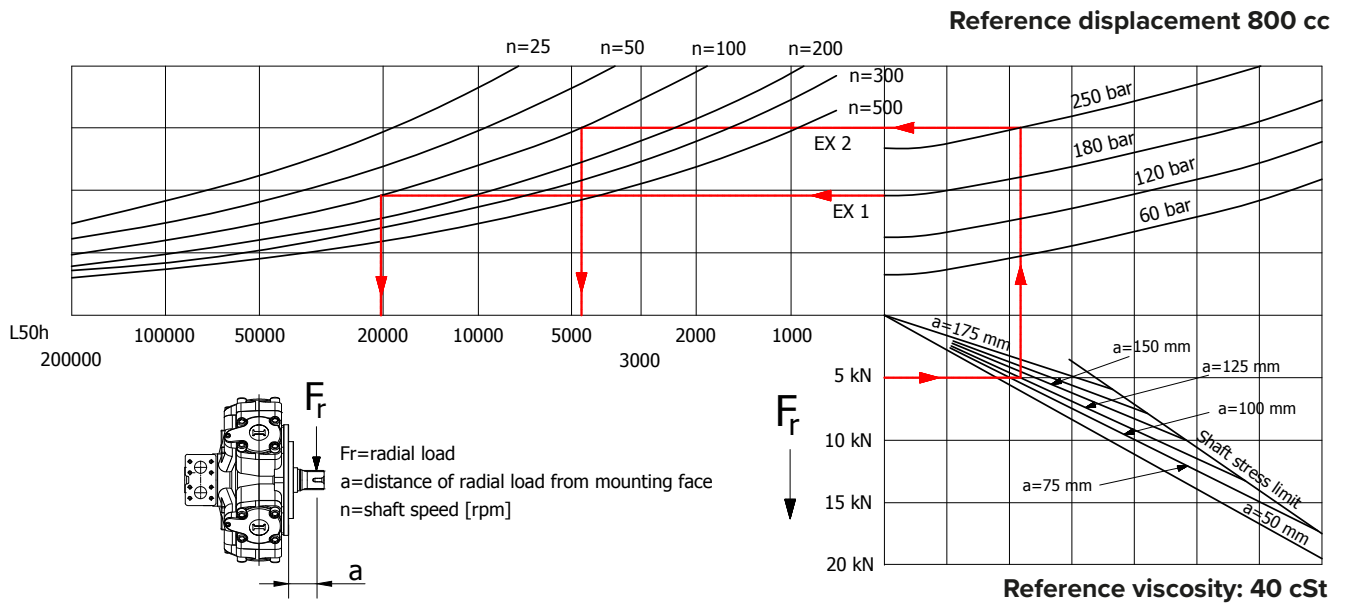

Example:

We suppose (EX1): $p=180$ [bar], $n=100$ [rpm]; we obtain an average lifetime of 25000 [h].

If we suppose (EX2): $F_r=10$ [kN], $a=150$ [mm], $n=100$ [rpm] and $p=180$ [bar] we obtain an average lifetime of 18000 [h].

The above data are referring to the R8M H4 series motors, displacement 800 cc.

R8M H4 - ORDERING CODE

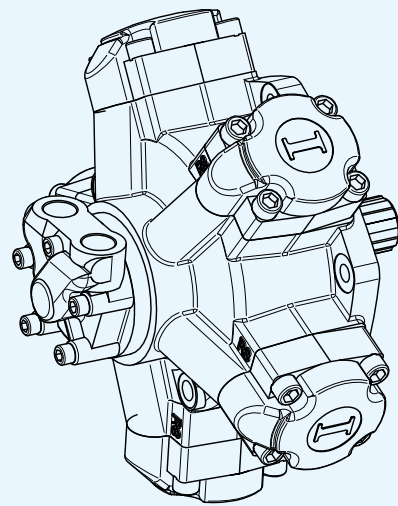
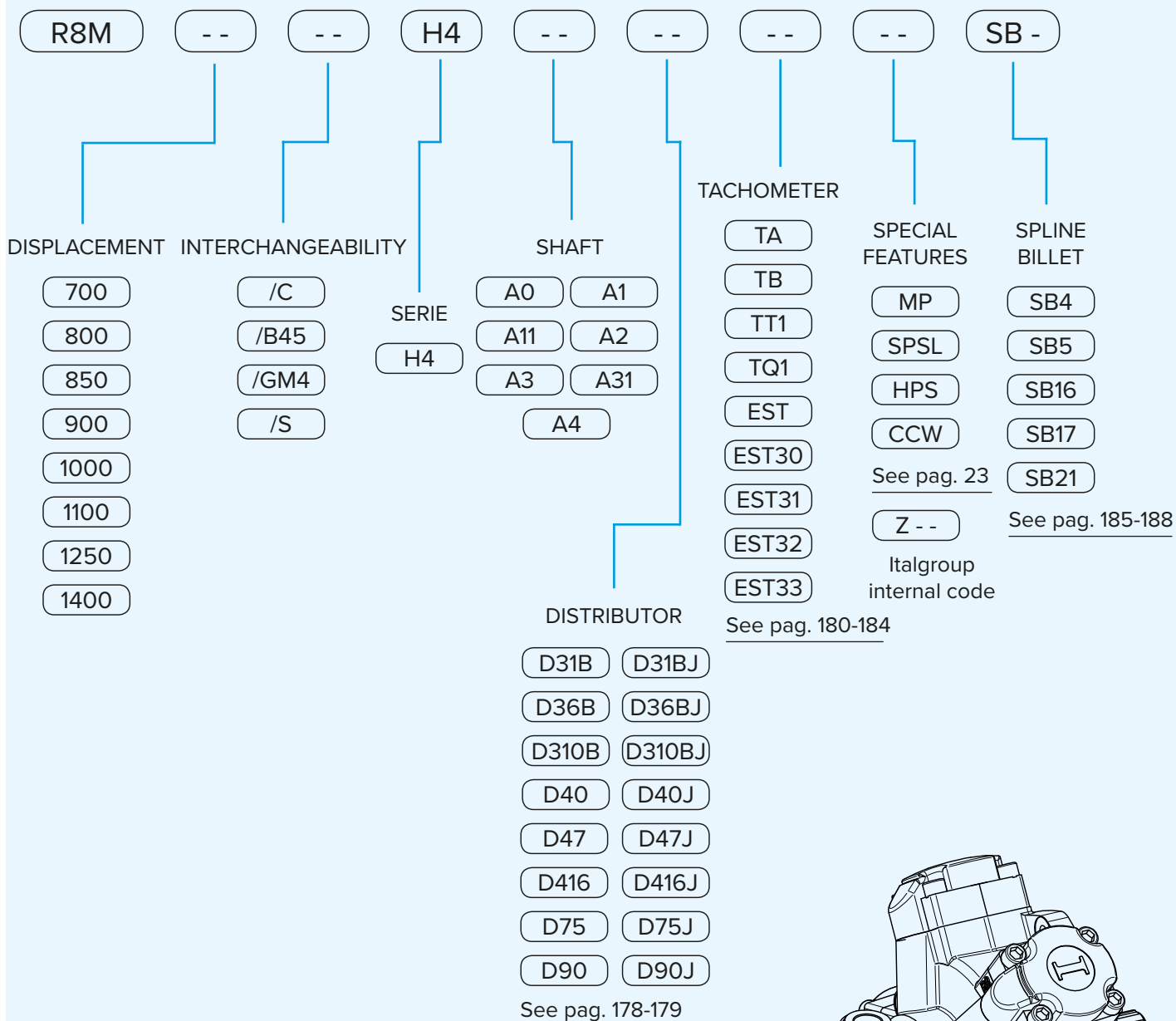

EXAMPLES:

- R8M 800 H4 A0 D40
- R8M 800/C H4 A0 D47
- R8M 1000/GM4 H4 A3 D47 CCW

R 8 M H 4 5

R8M H45	Pag. 112 - 113
R8M H45/C	Pag. 114 - 115
R8M H45 - PERFORMANCE CURVES	Pag. 116 - 118
R8M H45 - ORDERING CODE	Pag. 119

SHAFTS

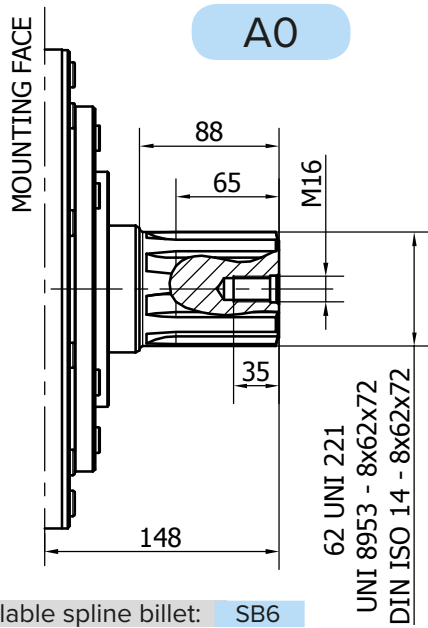

Available spline billet: SB6

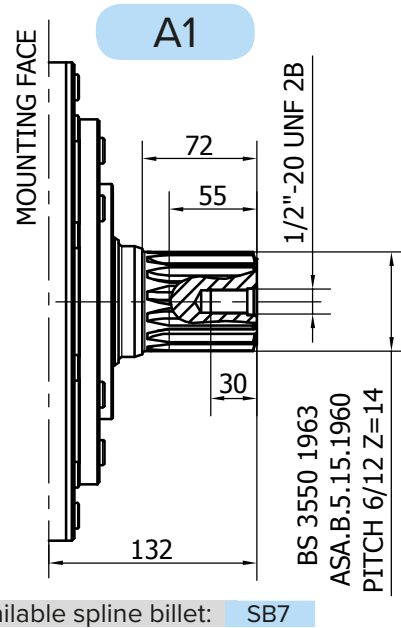

Available spline billet: SB7

R8M H45/C

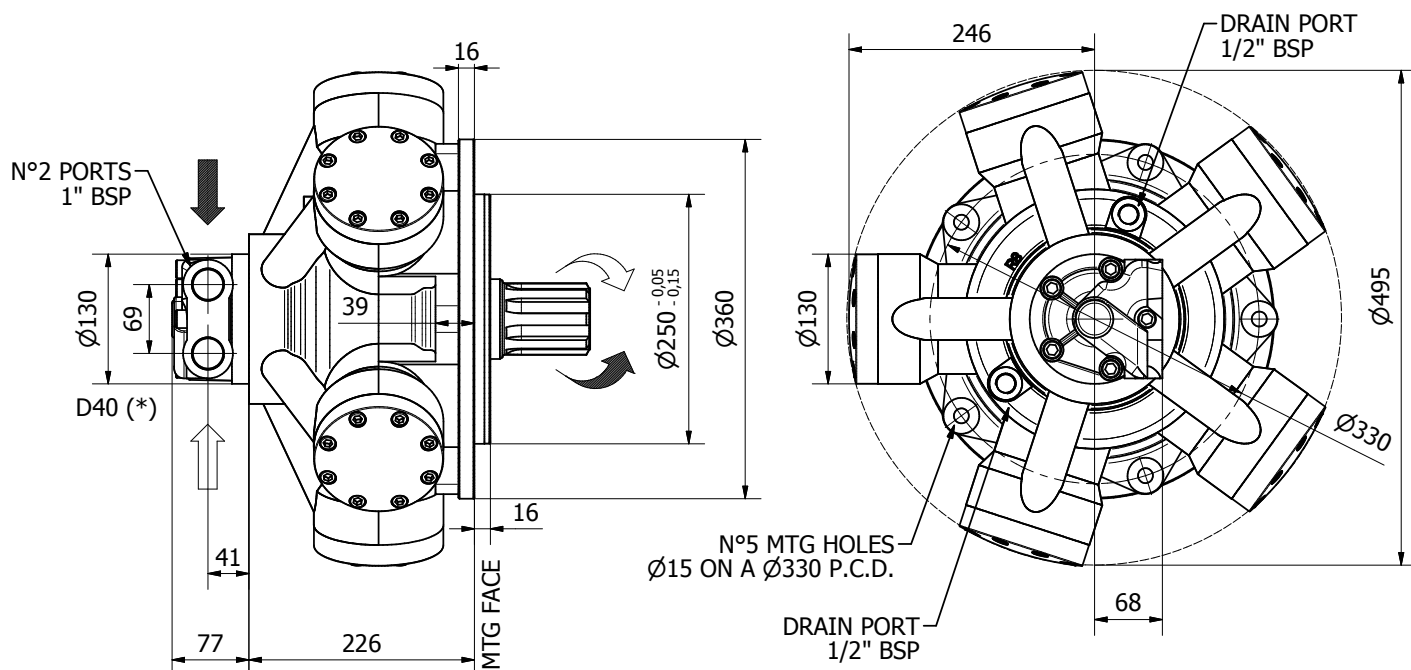

Available distributor flange: **FL4**

Refer to page 190-191
(distributor fitting D75)

TECHNICAL DATA

		1100	1400	1600
DISPLACEMENT	[cc]	1183	1376	1648
SPECIFIC TORQUE	[Nm/bar]	18.8	21.9	26.2
MAX. CONT. PRESSURE	[bar]	270	270	260
HYDROSTATIC TEST PRESSURE	[bar]	420	420	420
MAX. CONT. SPEED	[rpm]	350	300	275
PEAK SPEED (**)	[rpm]	400	350	325
MAX. CONT. POWER (***)	[kW]	85	85	85
MAX. POWER	[kW]	120	120	120
MAX. CASE PRESSURE	[bar]	6	6	6
DRY WEIGHT	[kg]	118	118	118
TEMPERATURE RANGE (**)	[°C]	-30÷70	-30÷70	-30÷70

- (*) The standard distributor (D40) is shown. Please refer to distributors section (pag. 178-179) for different distributor interfaces.

- (**) Please refer to the hydraulic fluid recommendations (pag. 10-11).

- (***) Do not exceed maximum power.

- (****) For motor operation with a continuous duty cycle at maximum continuous power the flushing is usually required (see pag. 13). For more information please contact our technical department.

SHAFTS

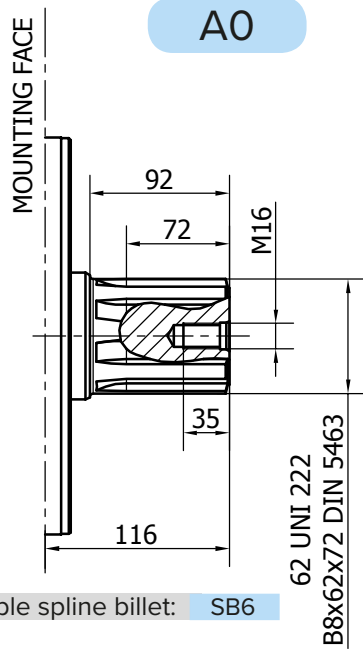

Available spline billet: **SB6**

R8M H45 - PERFORMANCE CURVES

R8M 1100 H45

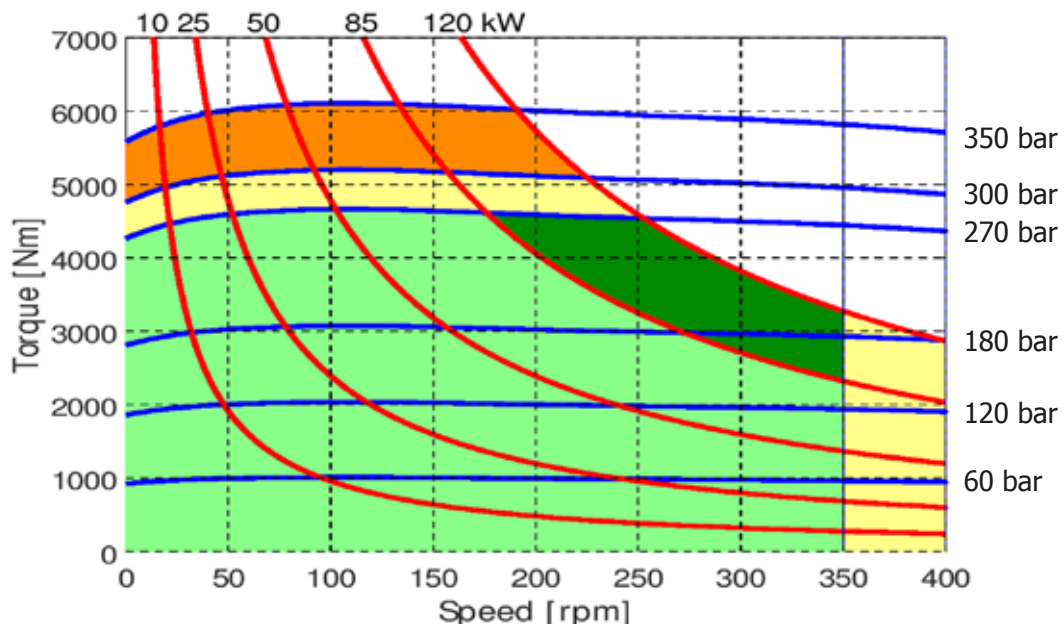

R8M 1400 H45

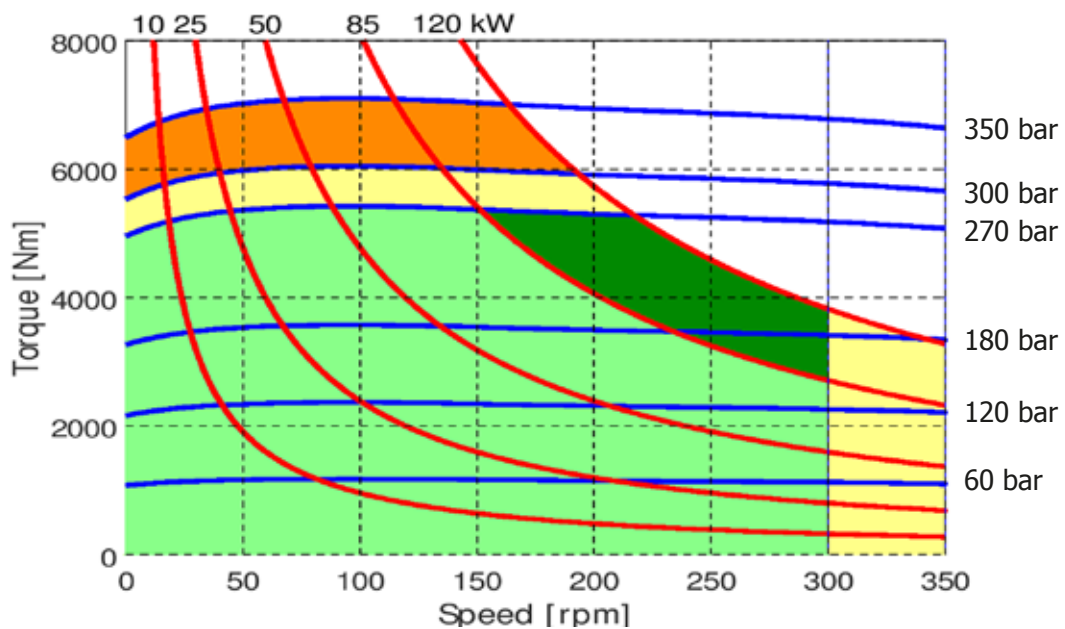

- Continuous operation
- Continuous operation with flushing or intermittent operation (see below for intermittent operation)
- Intermittent operation: permitted for a 15% of duty cycle, for 3 minutes maximum period
- Peak operation: permitted for very short periods (3-5 seconds every 10-15 minutes)

The above diagrams are referring to the hydraulic motor working with a fluid in ideal conditions (viscosity at 40 cSt). In case the working temperature increases and viscosity reach values under the recommended values (see hydraulic fluid recommendations) flushing must be performed or ISO oil grade must be changed. The working temperature must not overcome 70 °C.

R8M 1600 H45

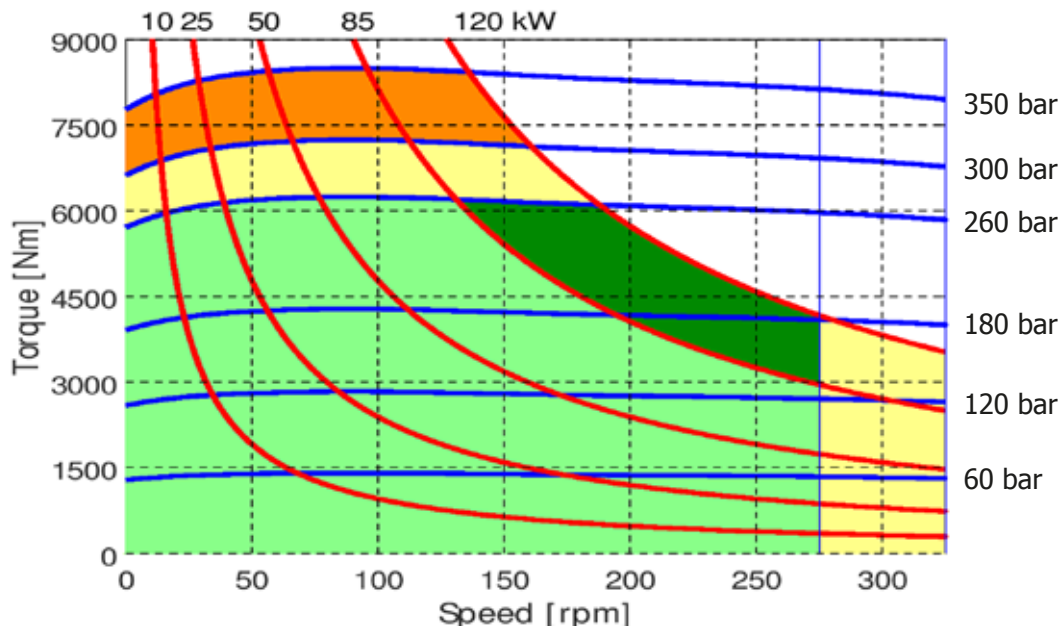

R8M 1800 H45

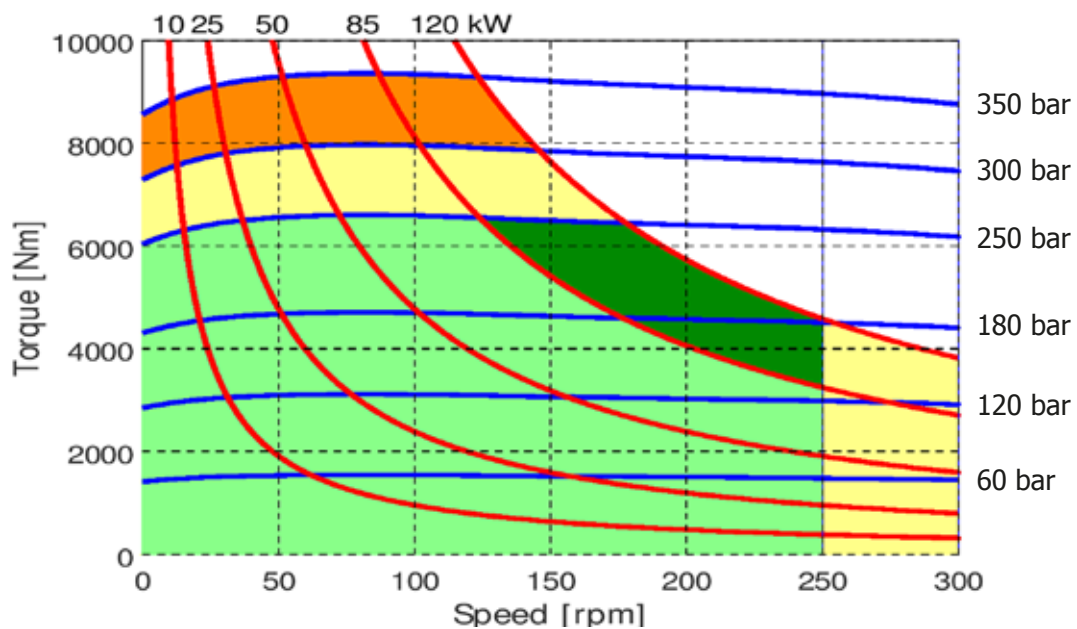

- Continuous operation
- Continuous operation with flushing or intermittent operation (see below for intermittent operation)
- Intermittent operation: permitted for a 15% of duty cycle, for 3 minutes maximum period
- Peak operation: permitted for very short periods (3-5 seconds every 10-15 minutes)

The above diagrams are referring to the hydraulic motor working with a fluid in ideal conditions (viscosity at 40 cSt). In case the working temperature increases and viscosity reach values under the recommended values (see hydraulic fluid recommendations) flushing must be performed or ISO oil grade must be changed. The working temperature must not overcome 70 °C.

R8M H45 - PERFORMANCE CURVES

BEARING LIFE

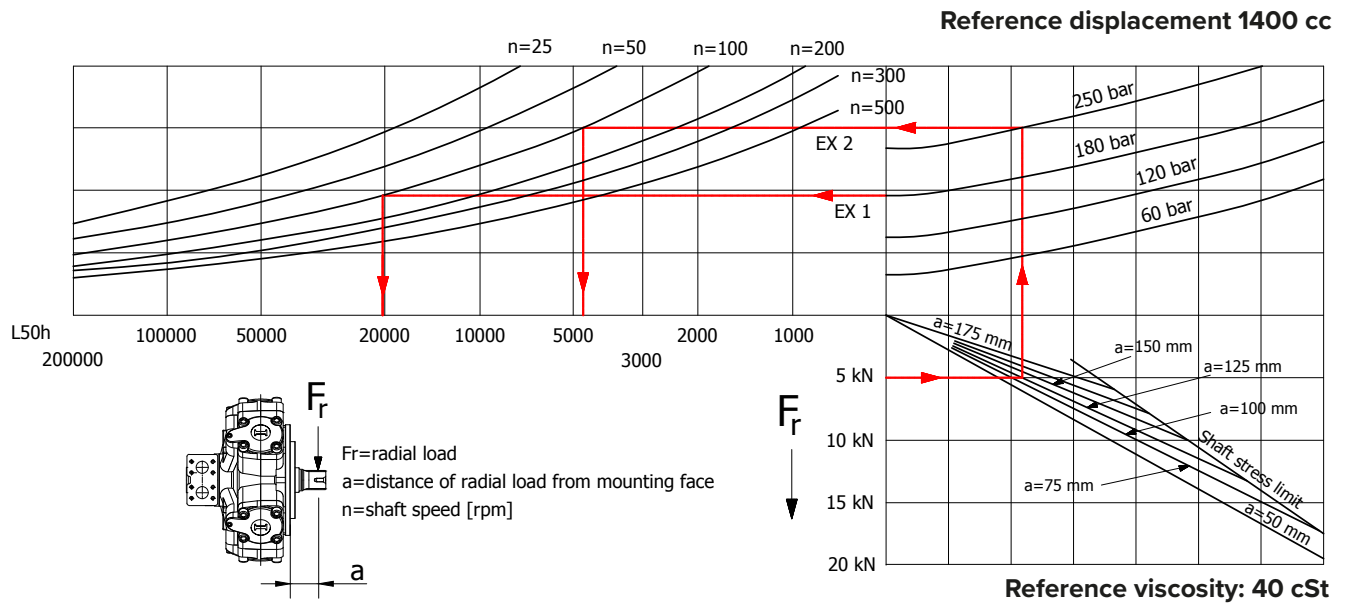

Example:

We suppose (EX2): $p=180$ [bar], $n=200$ [rpm]; we obtain an average lifetime of 22000 [h].

If we suppose (EX1): $F_r=15$ [kN], $a=150$ [mm], $n=200$ [rpm] and $p=120$ [bar] we obtain an average lifetime of 51000 [h].

The above data are referring to the R8M H45 series motors, displacement 1400 cc.

R8M H45 - ORDERING CODE

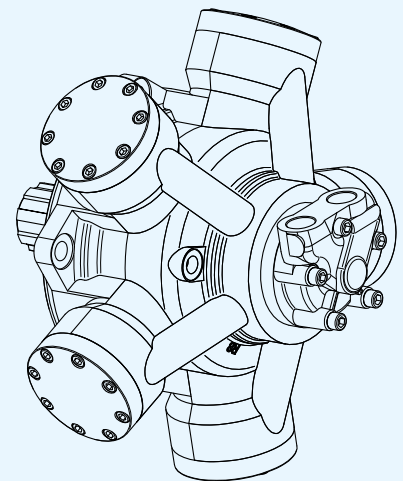
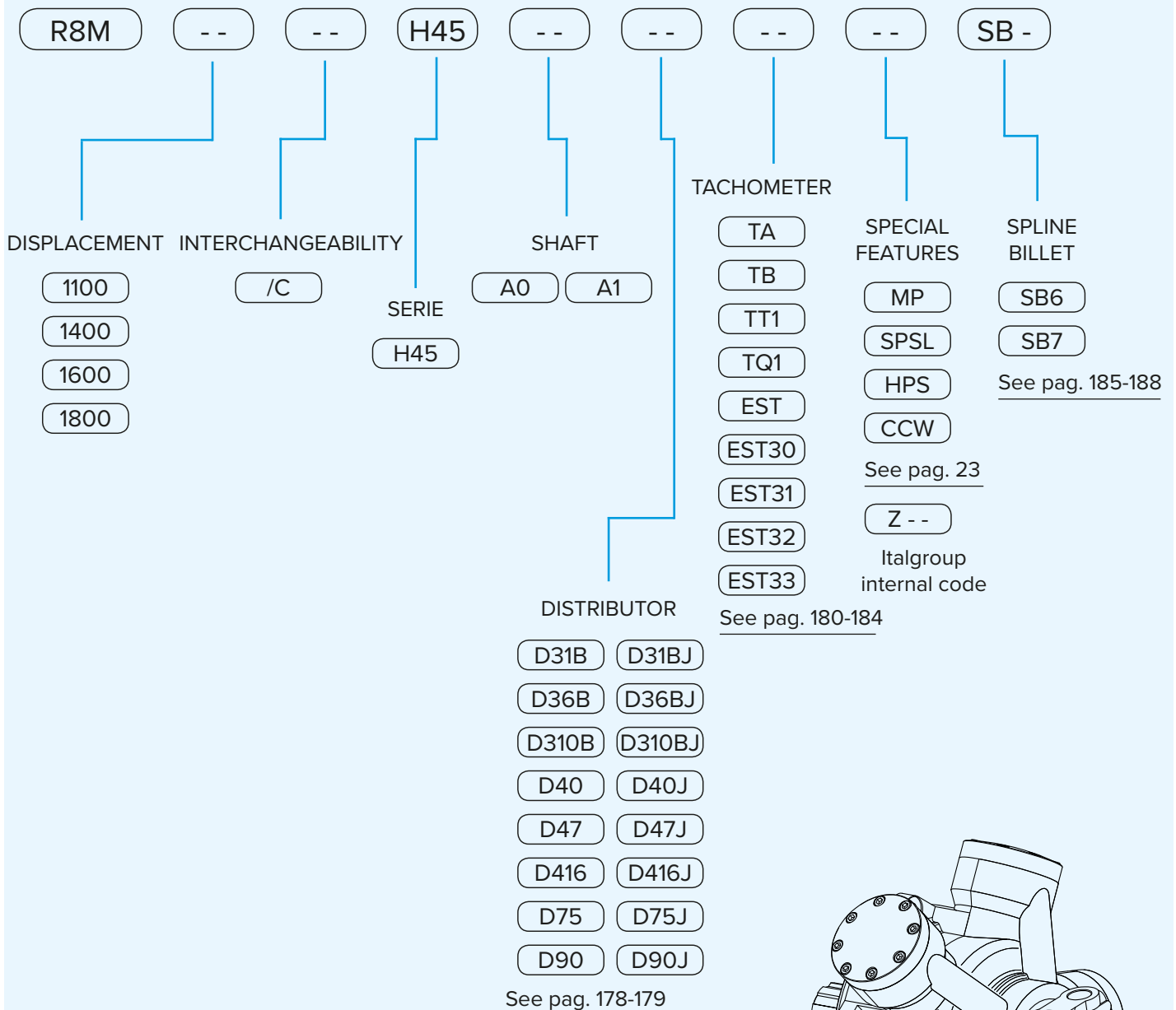

EXAMPLES:

R8M 1100 H45 A0 D75
R8M 1100/C H45 A0 D47
R8M 1400/C H45 A0 D75 SB6

R 8 M H 5

R8M H5	Pag. 122 - 124
R8M H5/C1100	Pag. 126 - 127
R8M 1600-1800-2000-2200/C H5	Pag. 128 - 129
R8M 1000/B60-1400/B80-1600/B100 H5	Pag. 130 - 131
R8M H5/GM5 - R8M H5/S	Pag. 132 - 133
R8M H5 - PERFORMANCE CURVES	Pag. 134 - 138
R8M H5 - ORDERING CODE	Pag. 139

SHAFTS

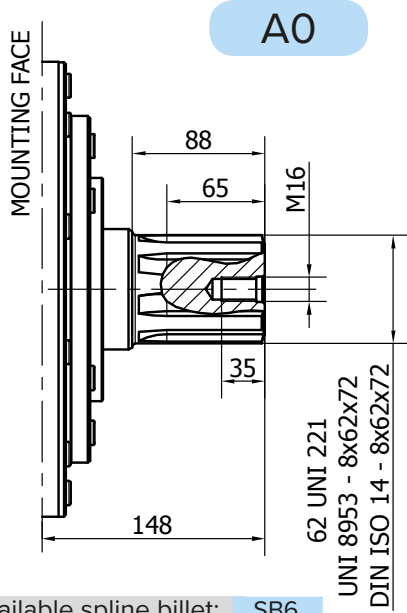

Available spline billet: SB6

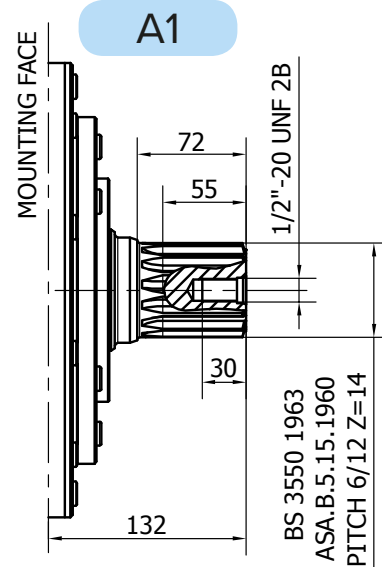

Available spline billet: SB7

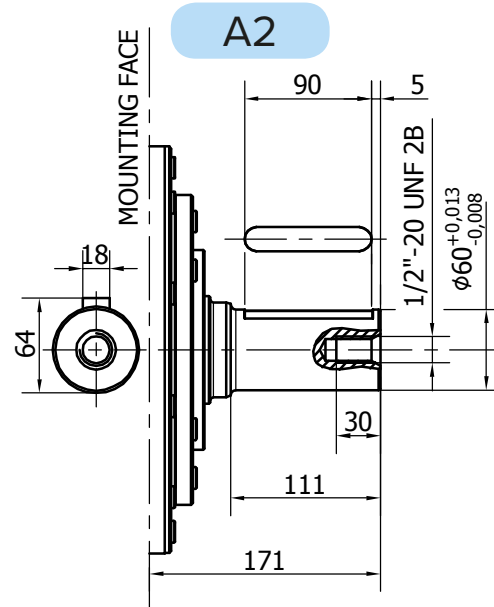
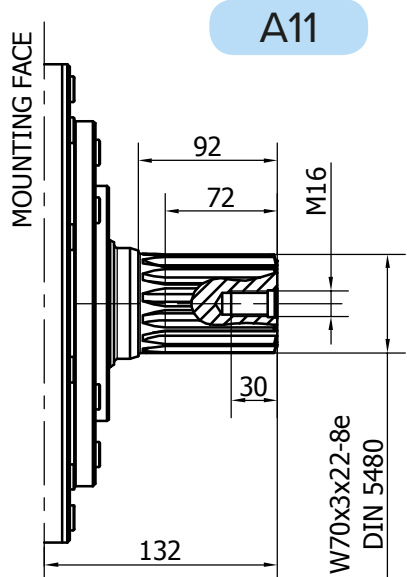

R8M H5

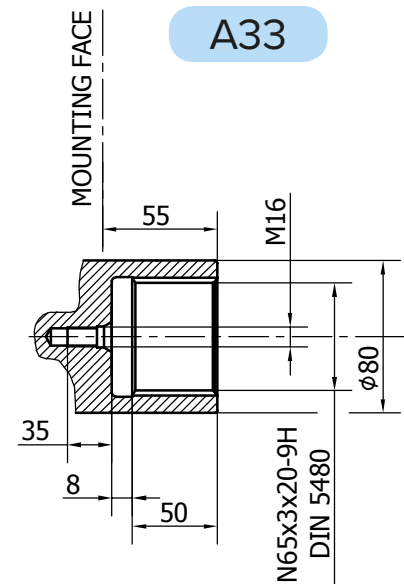
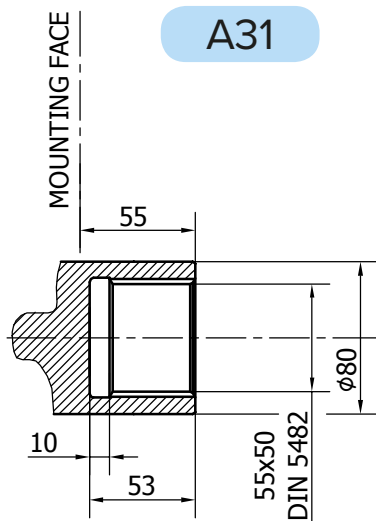
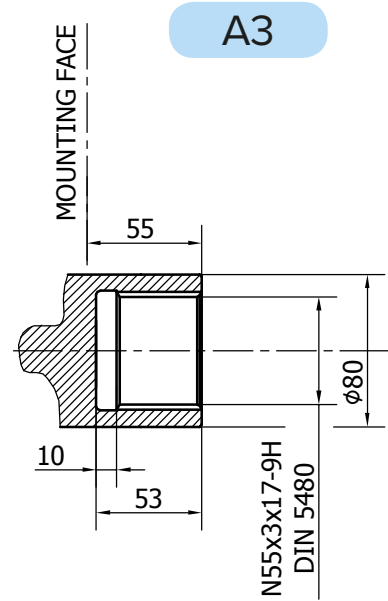
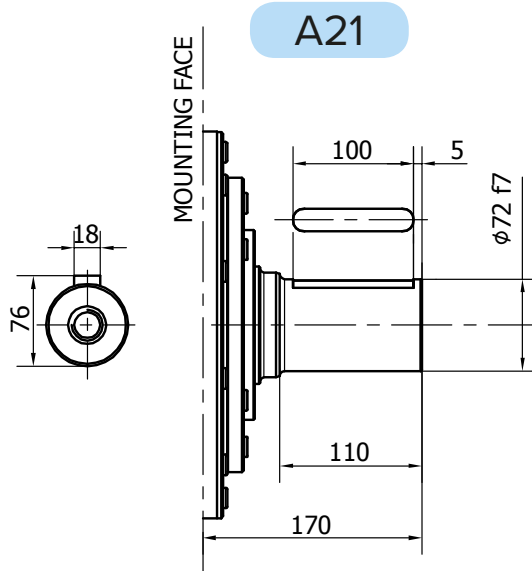

SHAFTS

R8M H5/C1100

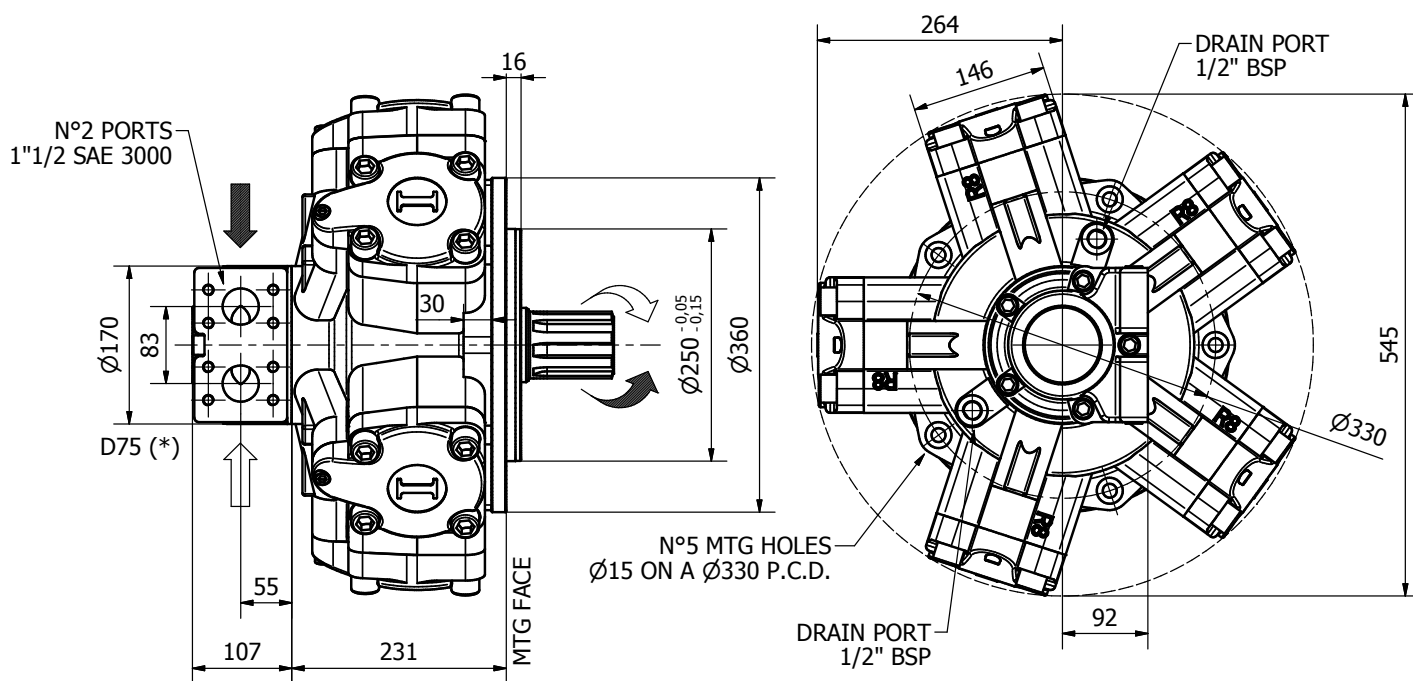

Available distributor flange: **FL4**

Refer to page 190-191
(distributor fitting D75)

TECHNICAL DATA

		1000	1200	1400	1500	1600	1800	2000	2200
DISPLACEMENT	[cc]	1094	1231	1376	1528	1648	1815	2035	2220
SPECIFIC TORQUE	[Nm/bar]	17.4	19.6	21.9	24.3	26.2	28.9	32.4	35.3
MAX. CONT. PRESSURE	[bar]	270	270	270	270	270	260	250	250
HYDROSTATIC TEST PRESSURE	[bar]	420	420	420	420	420	420	420	420
MAX. CONT. SPEED	[rpm]	350	300	300	300	300	250	230	220
PEAK SPEED (***)	[rpm]	400	350	350	350	340	300	260	240
MAX. CONT. POWER (****)	[kW]	92	92	92	92	92	92	92	92
MAX. POWER	[kW]	122	122	122	122	122	122	122	122
MAX. CASE PRESSURE	[bar]	6	6	6	6	6	6	6	6
DRY WEIGHT	[kg]	173	173	173	173	173	173	173	173
TEMPERATURE RANGE (**)	[°C]	-30÷70	-30÷70	-30÷70	-30÷70	-30÷70	-30÷70	-30÷70	-30÷70

- (*) The standard distributor (D75) is shown. Please refer to distributors section (pag. 178-179) for different distributor interfaces.

- (**) Please refer to the hydraulic fluid recommendations (pag. 10-11).

- (***) Do not exceed maximum power.

- (****) For motor operation with a continuous duty cycle at maximum continuous power the flushing is usually required (see pag. 13). For more information please contact our technical department.

SHAFTS

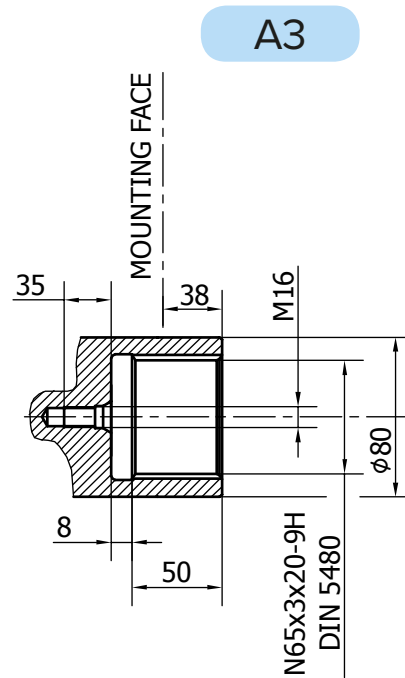
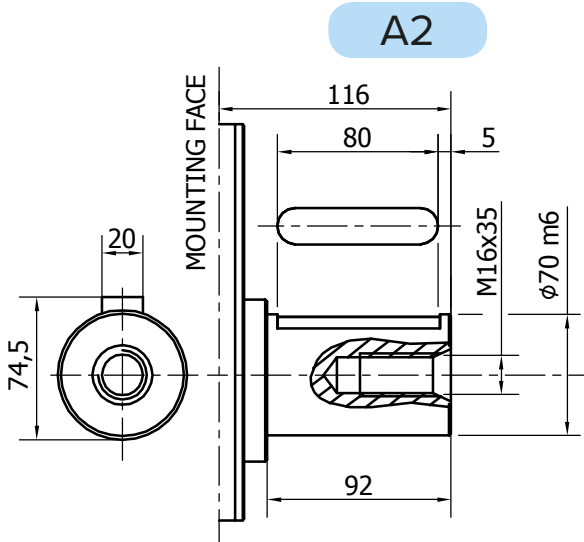
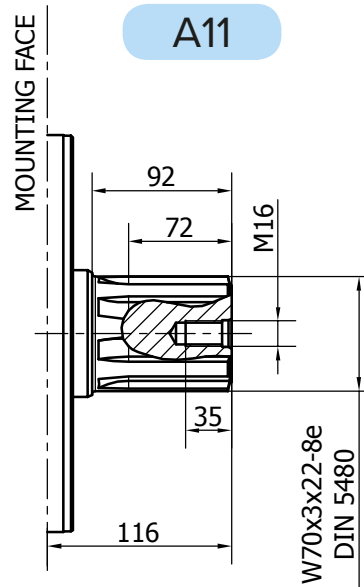
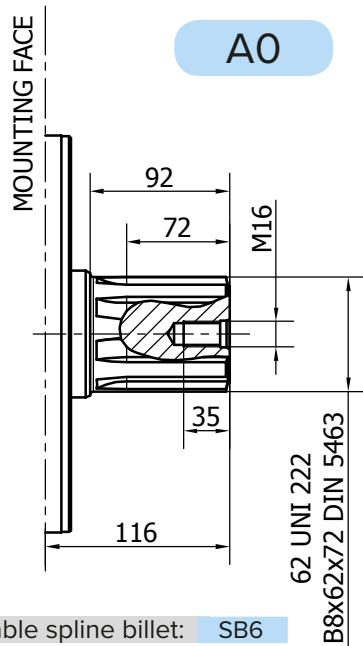

R8M 1600-1800-2000-2200/C H5

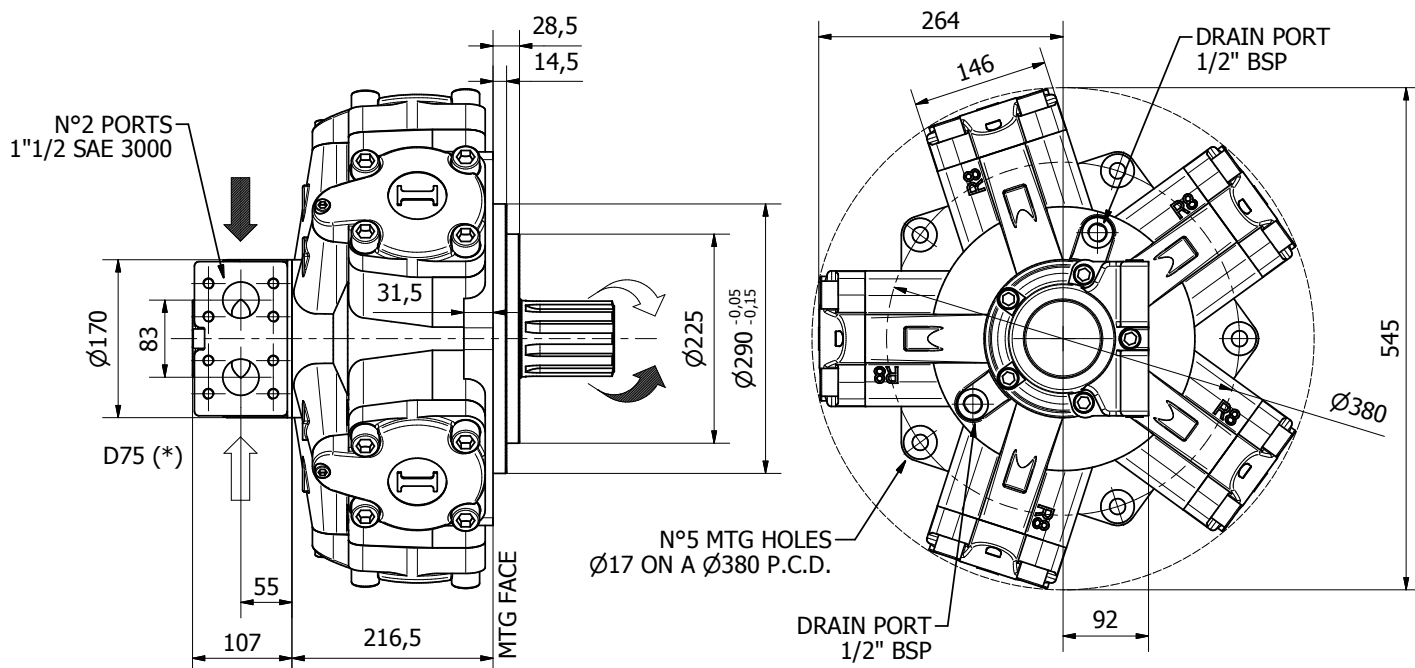

Available distributor flange: **FL4**

Refer to page 190-191
(distributor fitting D75)

TECHNICAL DATA

		1600	1800	2000	2200
DISPLACEMENT	[cc]	1648	1815	2035	2220
SPECIFIC TORQUE	[Nm/bar]	26.2	28.9	32.4	35.3
MAX. CONT. PRESSURE	[bar]	270	260	250	250
HYDROSTATIC TEST PRESSURE	[bar]	420	420	420	420
MAX. CONT. SPEED	[rpm]	300	250	230	220
PEAK SPEED (***)	[rpm]	340	300	260	240
MAX. CONT. POWER (****)	[kW]	92	92	92	92
MAX. POWER	[kW]	122	122	122	122
MAX. CASE PRESSURE	[bar]	6	6	6	6
DRY WEIGHT	[kg]	173	173	173	173
TEMPERATURE RANGE (**)	[°C]	-30÷70	-30÷70	-30÷70	-30÷70

- (*) The standard distributor (D75) is shown. Please refer to distributors section (pag. 178-179) for different distributor interfaces.

- (**) Please refer to the hydraulic fluid recommendations (pag. 10-11).

- (***) Do not exceed maximum power.

- (****) For motor operation with a continuous duty cycle at maximum continuous power the flushing is usually required (see pag. 13). For more information please contact our technical department.

SHAFTS

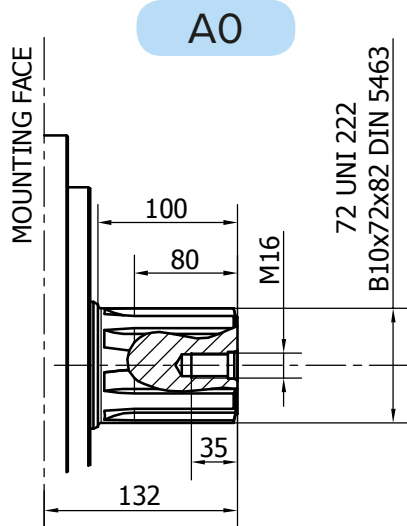

Available spline billet: SB8

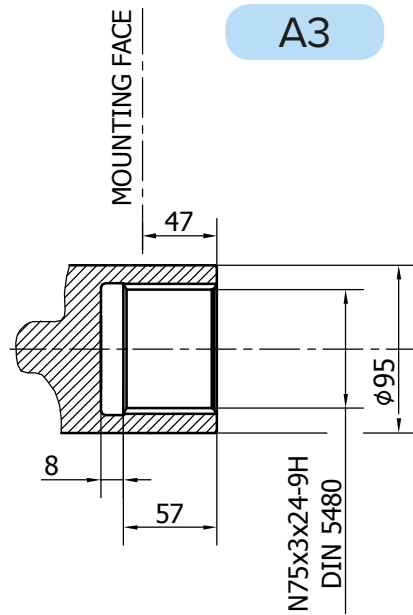
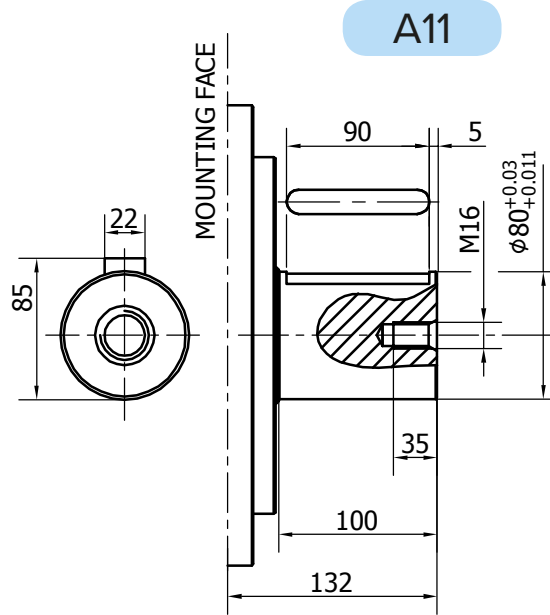

R8M 1000/B60-1400/B80-1600/B100

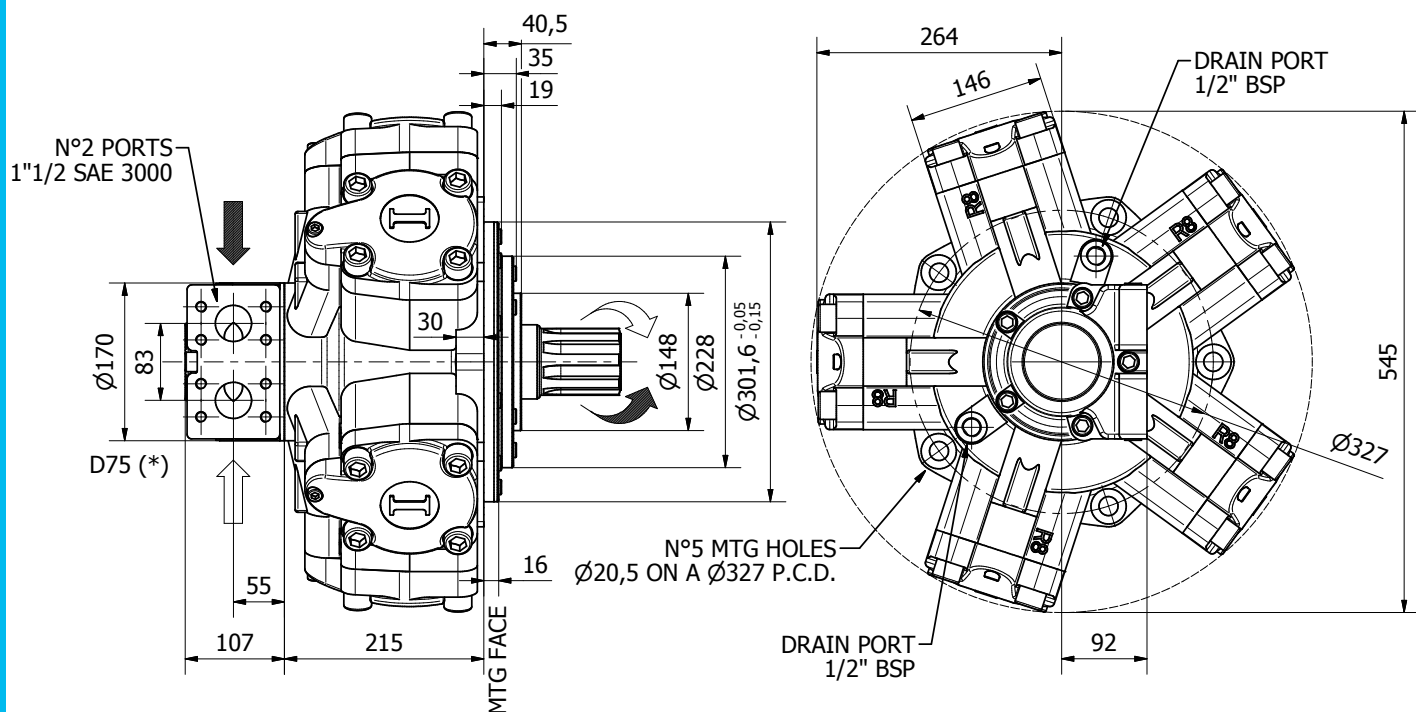

Available distributor flanges: **FL5** **FL6**

For S03 and S04, refer to page
190-191 (distributor fitting D75)

TECHNICAL DATA

		1000	1400	1600
DISPLACEMENT	[cc]	1094	1376	1648
SPECIFIC TORQUE	[Nm/bar]	17.4	21.9	26.2
MAX. CONT. PRESSURE	[bar]	270	270	270
HYDROSTATIC TEST PRES- SURE	[bar]	420	420	420
MAX. CONT. SPEED	[rpm]	350	300	300
PEAK SPEED (**)	[rpm]	400	350	340
MAX. CONT. POWER (***)	[kW]	92	92	92
MAX. POWER	[kW]	122	122	122
MAX. CASE PRESSURE	[bar]	6	6	6
DRY WEIGHT	[kg]	173	173	173
TEMPERATURE RANGE (**)	[°C]	-30÷70	-30÷70	-30÷70

- (*) The standard distributor (D75) is shown. Please refer to distributors section (pag. 178-179) for different distributor interfaces.

- (**) Please refer to the hydraulic fluid recommendations (pag. 10-11).

- (***) Do not exceed maximum power.

- (****) For motor operation with a continuous duty cycle at maximum continuous power the flushing is usually required (see pag. 13). For more information please contact our technical department.

SHAFTS

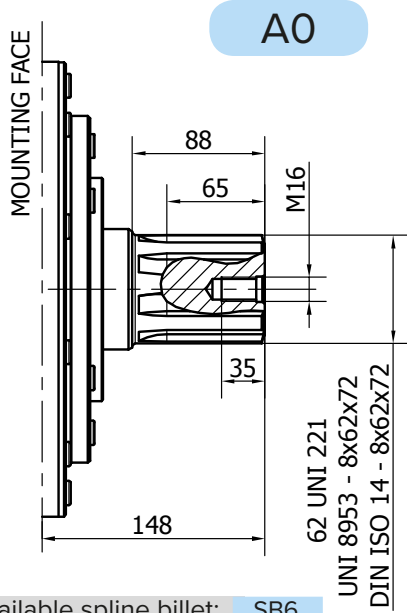

Available spline billet: SB6

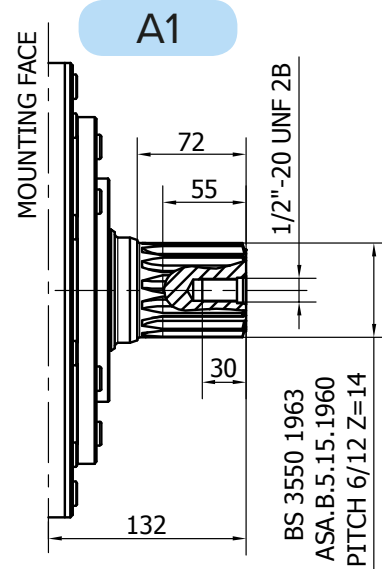

Available spline billet: SB7

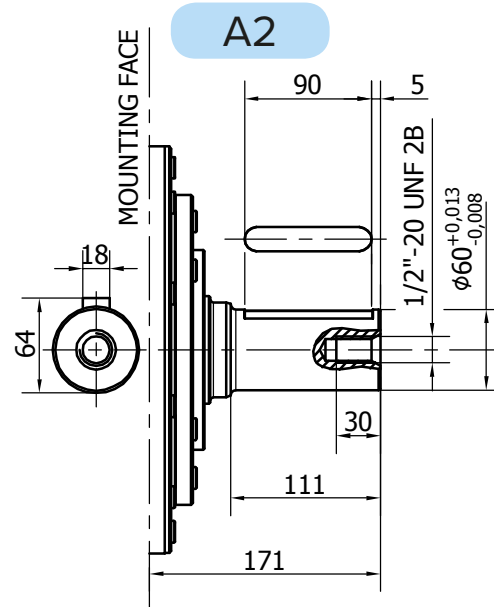
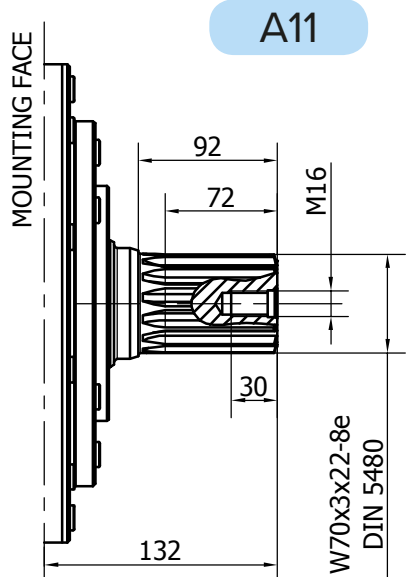

R8M H5/GM5 - R8M H5/S

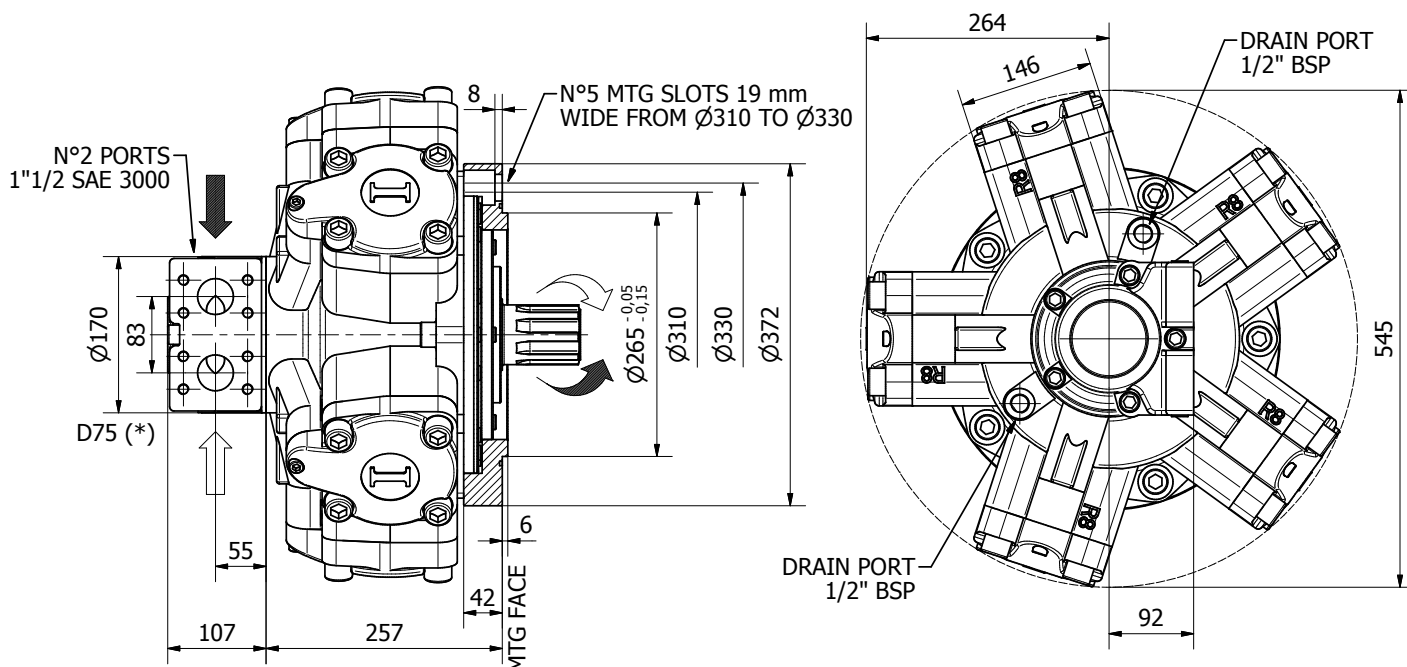

TECHNICAL DATA

		1000	1200	1400	1500	1600	1800	2000	2200
DISPLACEMENT	[cc]	1094	1231	1376	1528	1648	1815	2035	2220
SPECIFIC TORQUE	[Nm/bar]	17.4	19.6	21.9	24.3	26.2	28.9	32.4	35.3
MAX. CONT. PRESSURE	[bar]	270	270	270	270	270	260	250	250
HYDROSTATIC TEST PRESSURE	[bar]	420	420	420	420	420	420	420	420
MAX. CONT. SPEED	[rpm]	350	300	300	300	300	250	230	220
PEAK SPEED (***)	[rpm]	400	350	350	350	340	300	260	240
MAX. CONT. POWER (****)	[kW]	92	92	92	92	92	92	92	92
MAX. POWER	[kW]	122	122	122	122	122	122	122	122
MAX. CASE PRESSURE	[bar]	6	6	6	6	6	6	6	6
DRY WEIGHT	[kg]	173	173	173	173	173	173	173	173
TEMPERATURE RANGE (**)	[°C]	-30÷70	-30÷70	-30÷70	-30÷70	-30÷70	-30÷70	-30÷70	-30÷70

- (*) The standard distributor (D75) is shown. Please refer to distributors section (pag. 178-179) for different distributor interfaces.

- (**) Please refer to the hydraulic fluid recommendations (pag. 10-11).

- (***) Do not exceed maximum power.

- (****) For motor operation with a continuous duty cycle at maximum continuous power the flushing is usually required (see pag. 13). For more information please contact our technical department.

SHAFTS

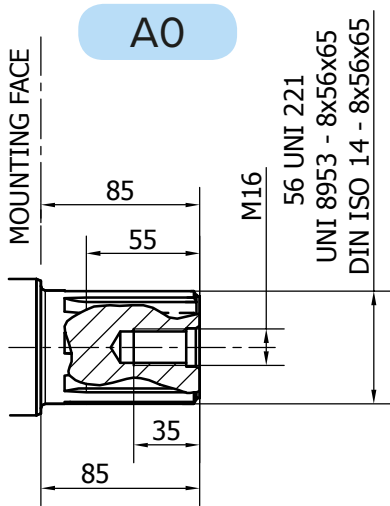

Available spline billet: SB17

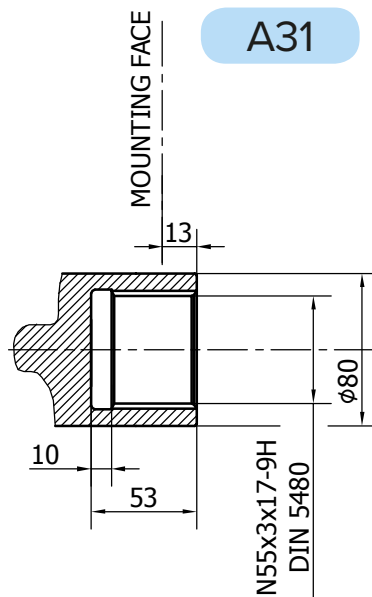
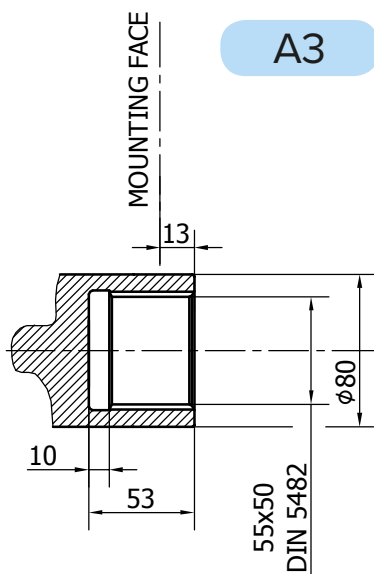
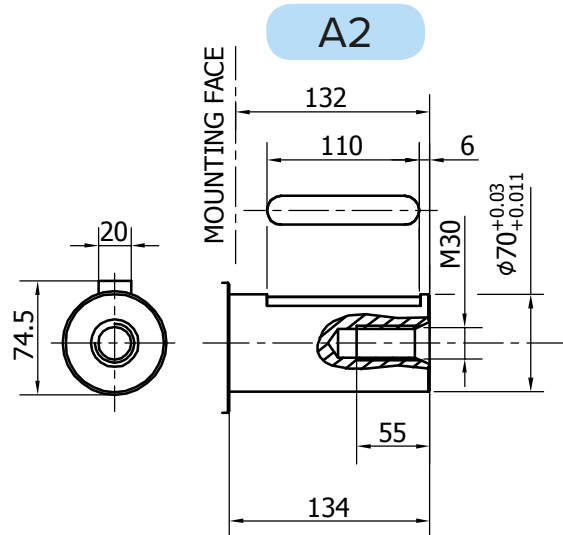

R8M H5 - PERFORMANCE CURVES

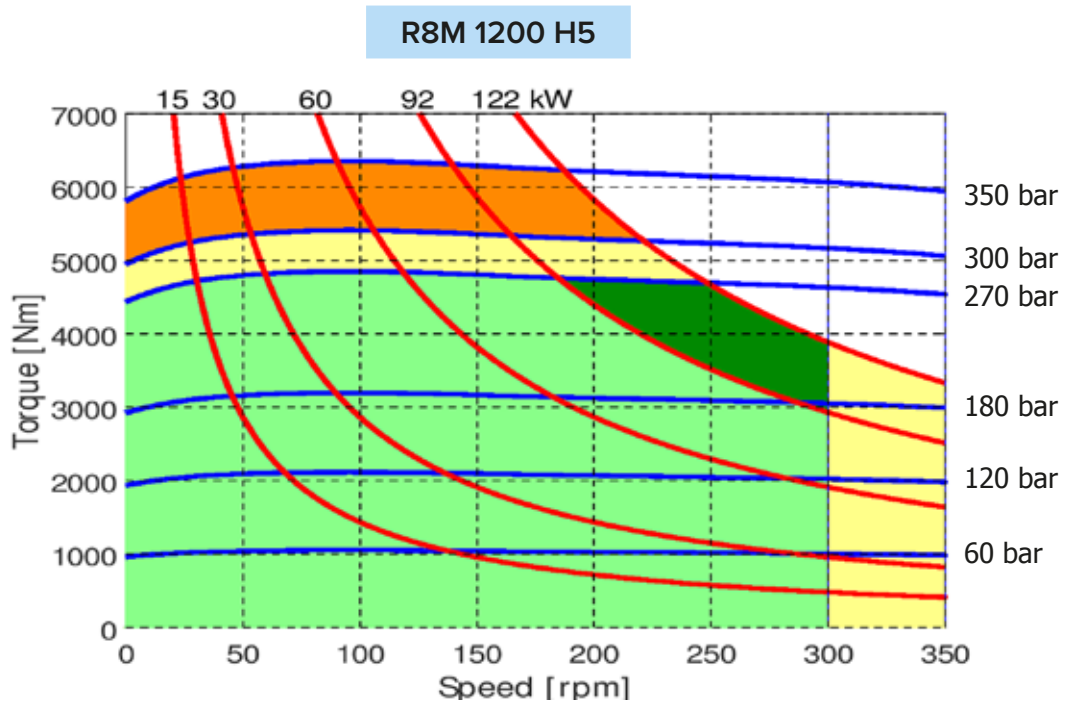
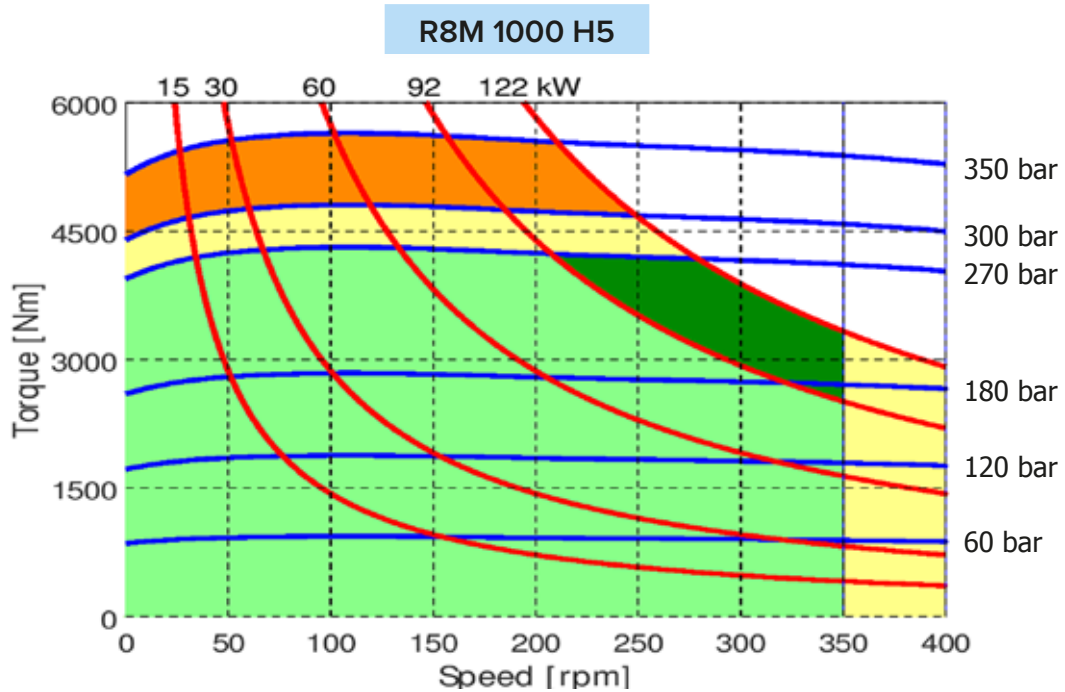

- Continuous operation
- Continuous operation with flushing or intermittent operation (see below for intermittent operation)
- Intermittent operation: permitted for a 15% of duty cycle, for 3 minutes maximum period
- Peak operation: permitted for very short periods (3-5 seconds every 10-15 minutes)

The above diagrams are referring to the hydraulic motor working with a fluid in ideal conditions (viscosity at 40 cSt). In case the working temperature increases and viscosity reach values under the recommended values (see hydraulic fluid recommendations) flushing must be performed or ISO oil grade must be changed. The working temperature must not overcome 70 °C.

R8M 1400 H5

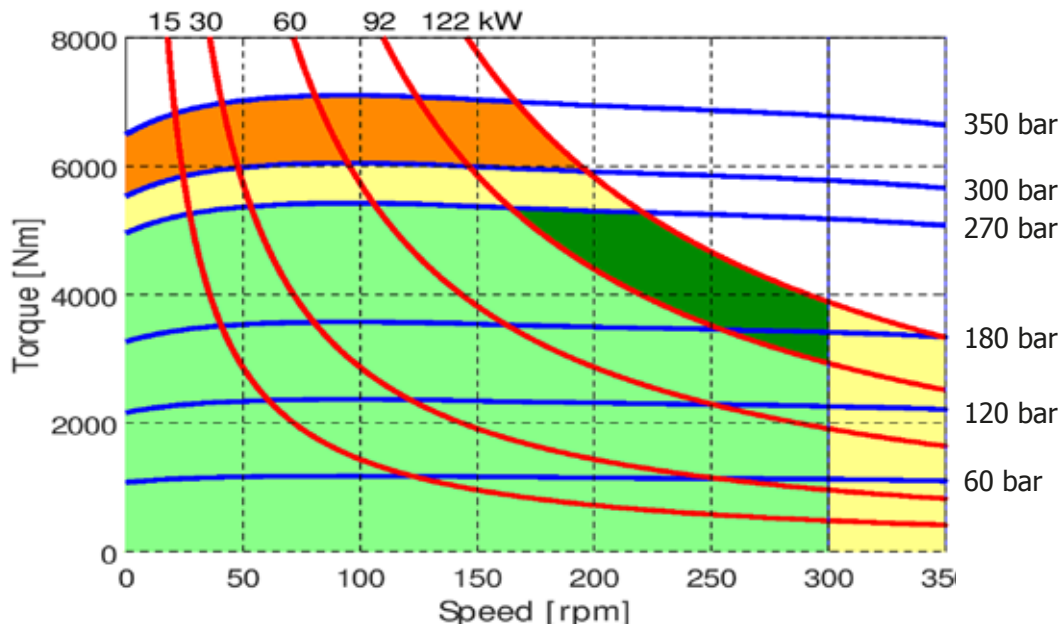

R8M 1500 H5

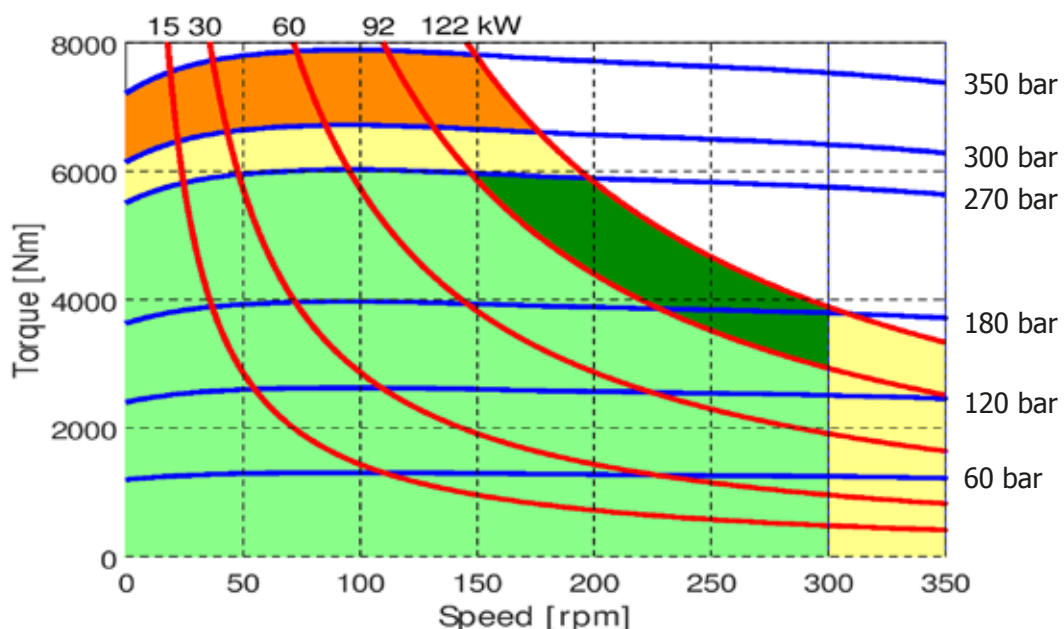

- Continuous operation
- Continuous operation with flushing or intermittent operation (see below for intermittent operation)
- Intermittent operation: permitted for a 15% of duty cycle, for 3 minutes maximum period
- Peak operation: permitted for very short periods (3-5 seconds every 10-15 minutes)

The above diagrams are referring to the hydraulic motor working with a fluid in ideal conditions (viscosity at 40 cSt). In case the working temperature increases and viscosity reach values under the recommended values (see hydraulic fluid recommendations) flushing must be performed or ISO oil grade must be changed. The working temperature must not overcome 70 °C.

R8M H5 - PERFORMANCE CURVES

R8M 1600 H5

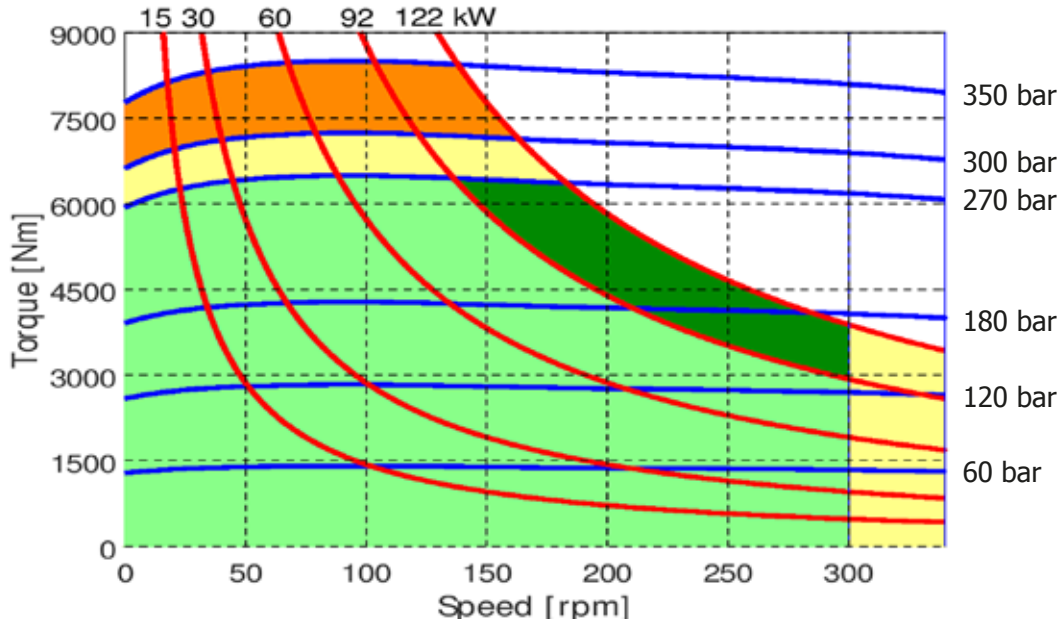

R8M 1800 H5

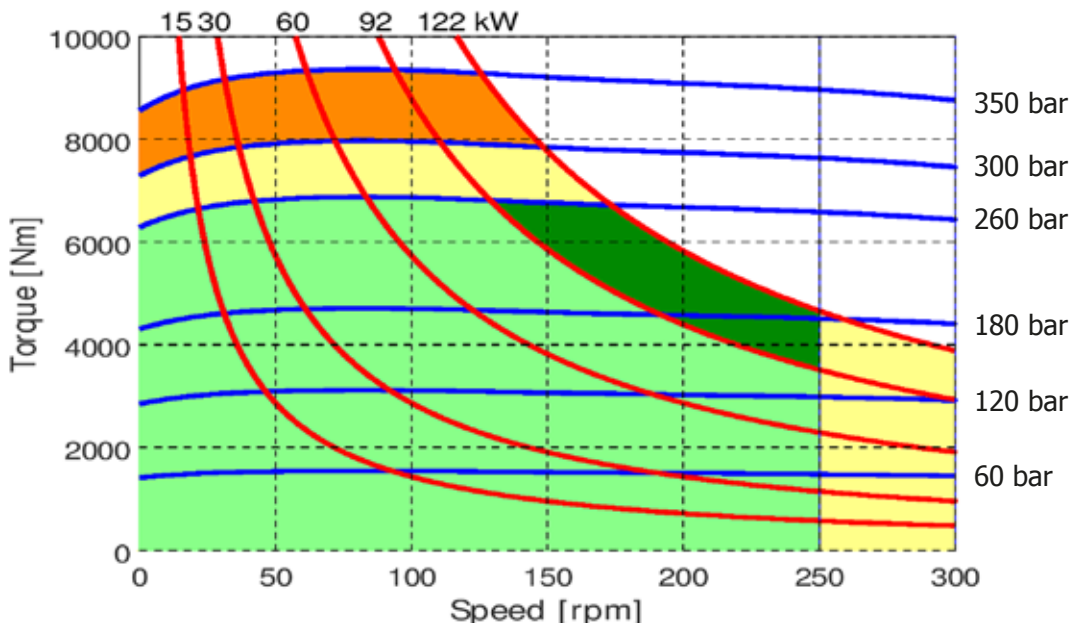

- Continuous operation
- Continuous operation with flushing or intermittent operation (see below for intermittent operation)
- Intermittent operation: permitted for a 15% of duty cycle, for 3 minutes maximum period
- Peak operation: permitted for very short periods (3-5 seconds every 10-15 minutes)

The above diagrams are referring to the hydraulic motor working with a fluid in ideal conditions (viscosity at 40 cSt). In case the working temperature increases and viscosity reach values under the recommended values (see hydraulic fluid recommendations) flushing must be performed or ISO oil grade must be changed. The working temperature must not overcome 70 °C.

R8M 2000 H5

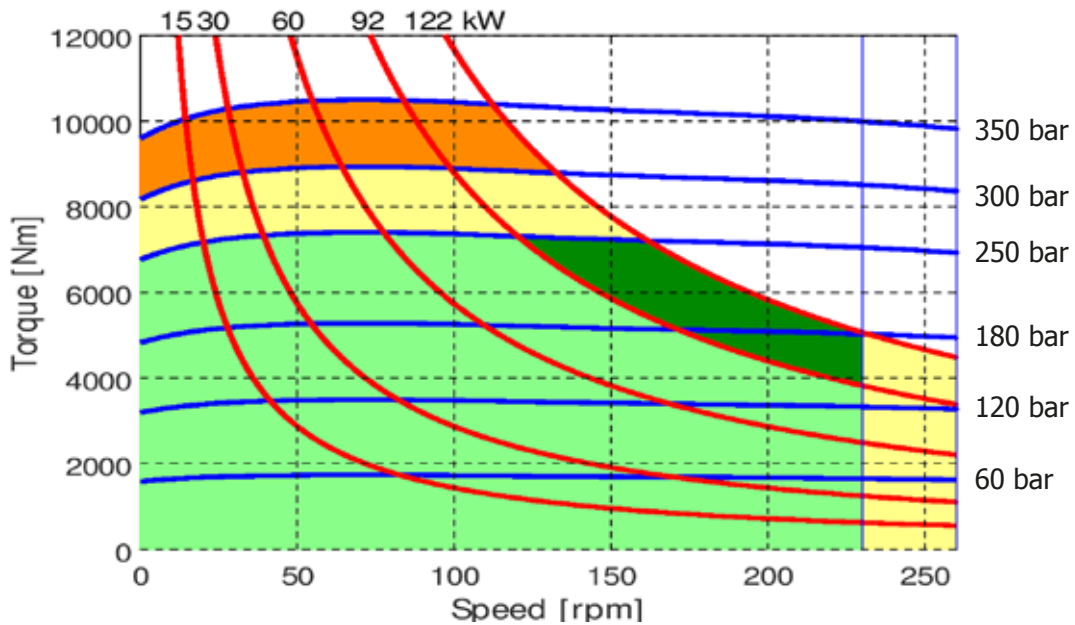

R8M 2200 H5

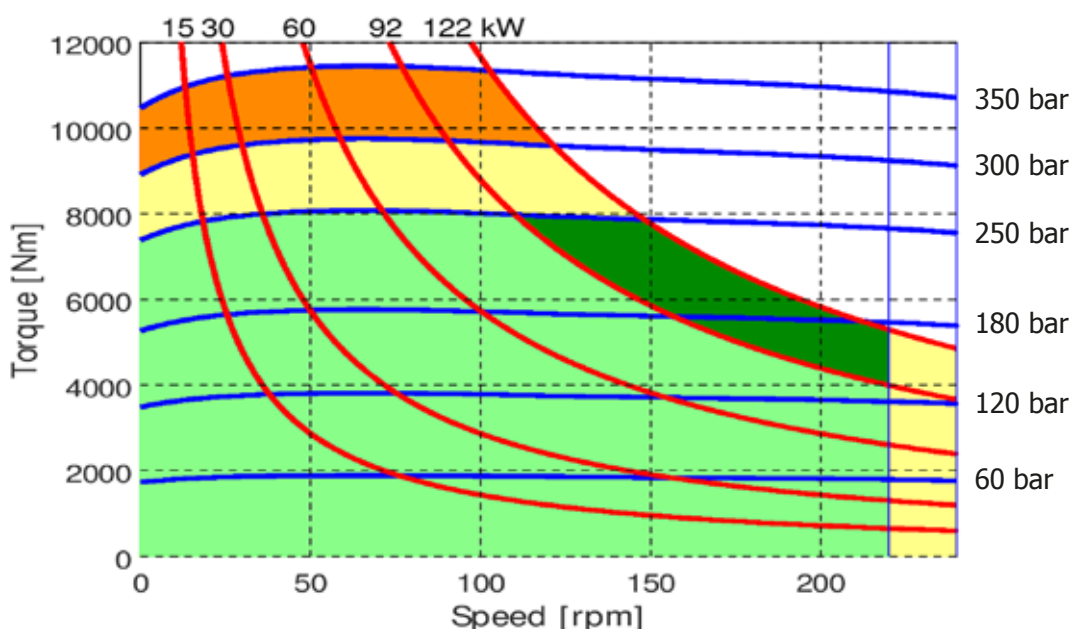

- Continuous operation
- Continuous operation with flushing or intermittent operation (see below for intermittent operation)
- Intermittent operation: permitted for a 15% of duty cycle, for 3 minutes maximum period
- Peak operation: permitted for very short periods (3-5 seconds every 10-15 minutes)

The above diagrams are referring to the hydraulic motor working with a fluid in ideal conditions (viscosity at 40 cSt). In case the working temperature increases and viscosity reach values under the recommended values (see hydraulic fluid recommendations) flushing must be performed or ISO oil grade must be changed. The working temperature must not overcome 70 °C.

R8M H5 - PERFORMANCE CURVES

BEARING LIFE

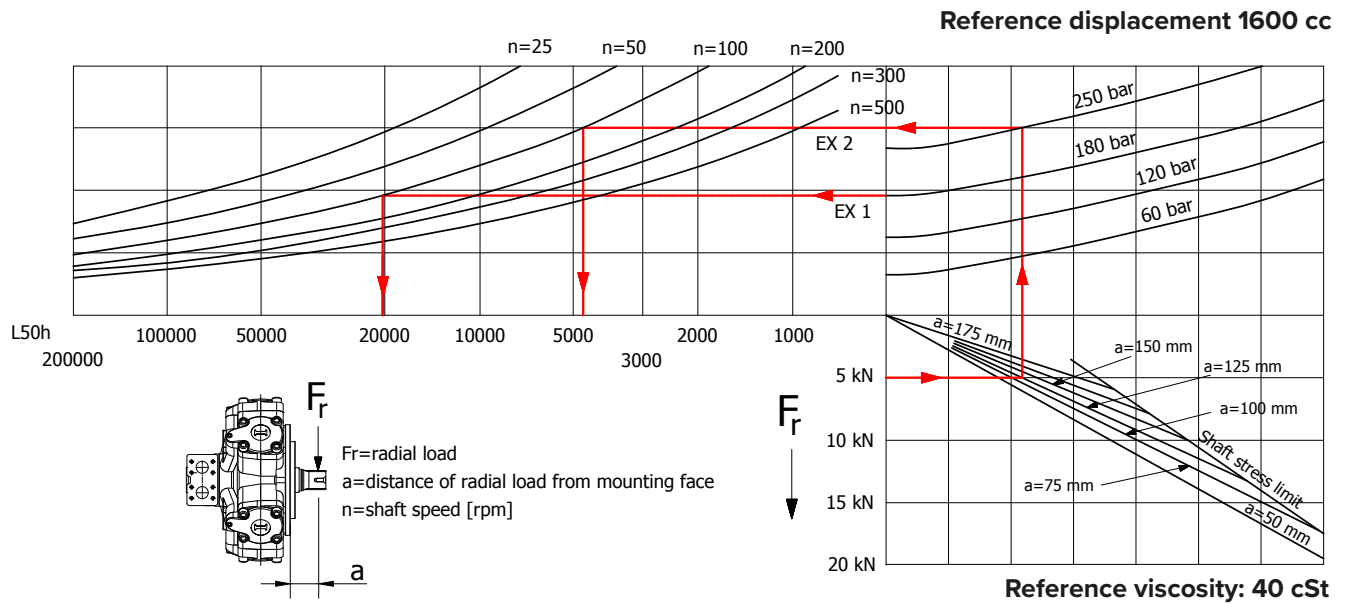

Example:

We suppose (EX1): $p=120$ [bar], $n=300$ [rpm]; we obtain an average lifetime of 33000 [h].

If we suppose (EX2): $F_r=15$ [kN], $a=150$ [mm], $n=200$ [rpm] and $p=180$ [bar] we obtain an average lifetime of 11000 [h].

The above data are referring to the R8M H5 series motors, displacement 1600 cc.

R8M H5 - ORDERING CODE

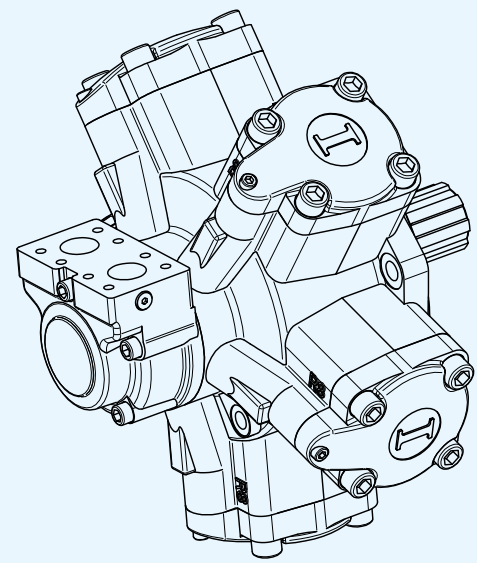
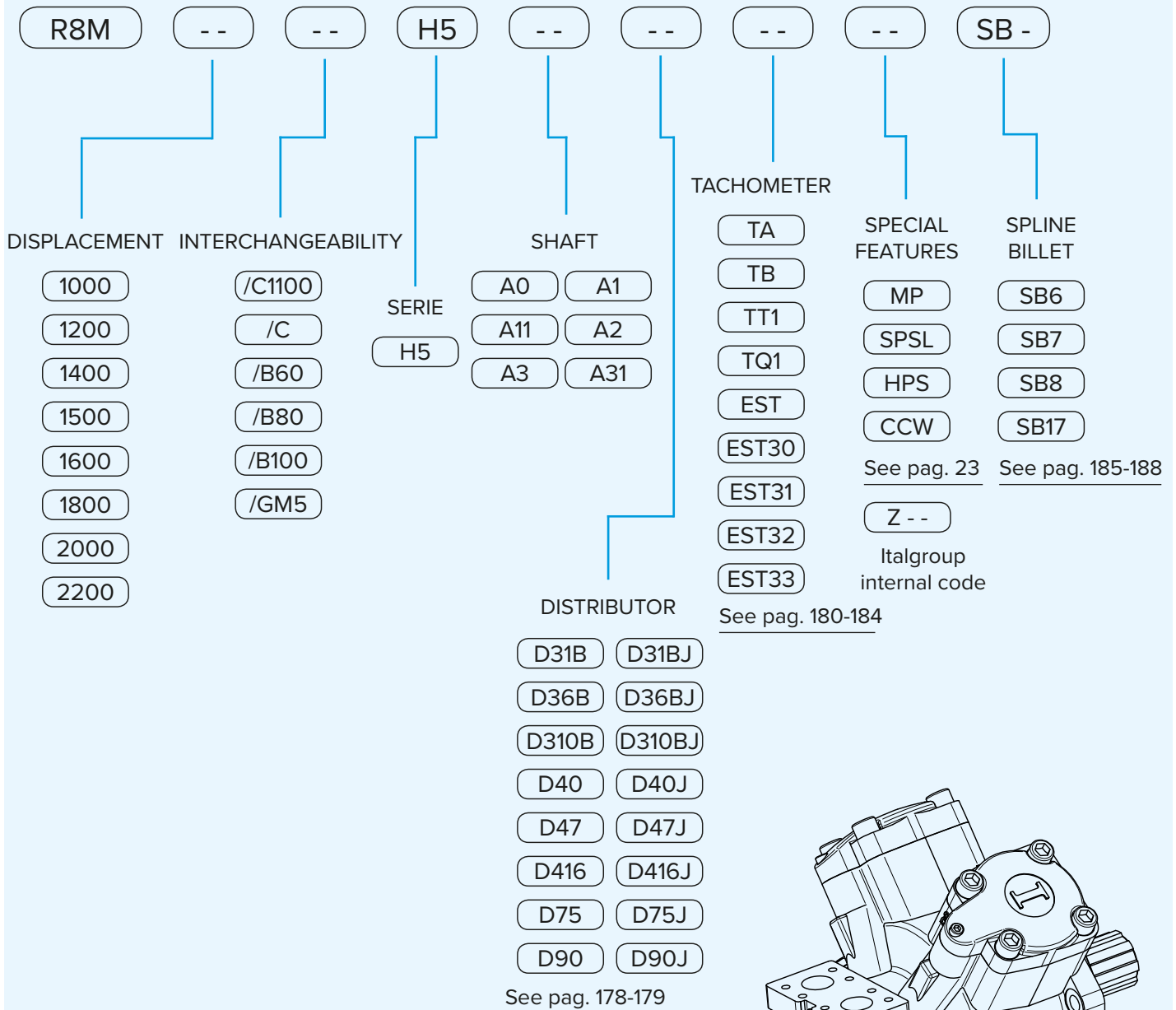

EXAMPLES:

- R8M 1000 H5 A1 D75 SB7
- R8M 1400/C H5 A2 D75
- R8M 2000 H5 A0 D90 CCW SB6

R 8 M H 5 5

R8M H55	Pag. 142 - 143
R8M H55/C	Pag. 144 - 145
R8M H55 - PERFORMANCE CURVES	Pag. 146 - 148
R8M H55 - ORDERING CODE	Pag. 149

R8M H55

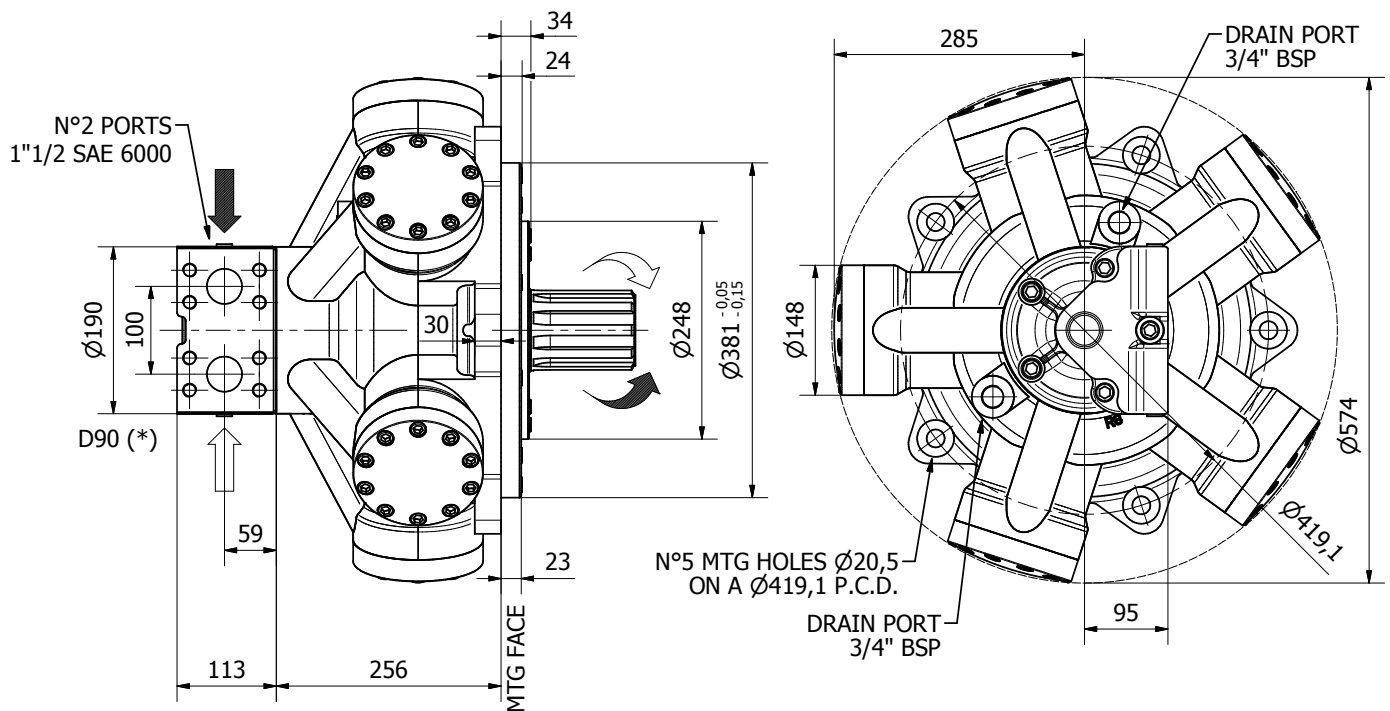

Available distributor flange: **FL7**

For S04, refer to page 190-191
(distributor fitting D90)

TECHNICAL DATA

		2200	2500	2800	3000
DISPLACEMENT	[cc]	2126	2525	2807	2983
SPECIFIC TORQUE	[Nm/bar]	33.8	40.2	44.7	48.2
MAX. CONT. PRESSURE	[bar]	270	270	260	260
HYDROSTATIC TEST PRESSURE	[bar]	420	420	420	420
MAX. CONT. SPEED	[rpm]	240	240	240	230
PEAK SPEED (***)	[rpm]	280	280	280	270
MAX. CONT. POWER (****)	[kW]	120	120	120	120
MAX. POWER	[kW]	170	170	170	170
MAX. CASE PRESSURE	[bar]	6	6	6	6
DRY WEIGHT	[kg]	203	203	203	203
TEMPERATURE RANGE (**)	[°C]	-30÷70	-30÷70	-30÷70	-30÷70

- (*) The standard distributor (D90) is shown. Please refer to distributors section (pag. 178-179) for different distributor interfaces.

- (**) Please refer to the hydraulic fluid recommendations (pag. 10-11).

- (***) Do not exceed maximum power.

- (****) For motor operation with a continuous duty cycle at maximum continuous power the flushing is usually required (see pag. 13). For more information please contact our technical department.

SHAFTS

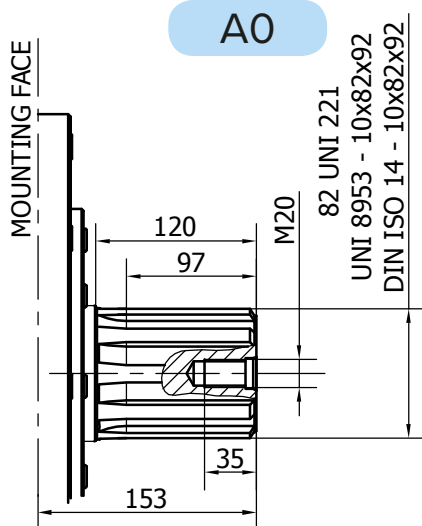

Available spline billet: SB9

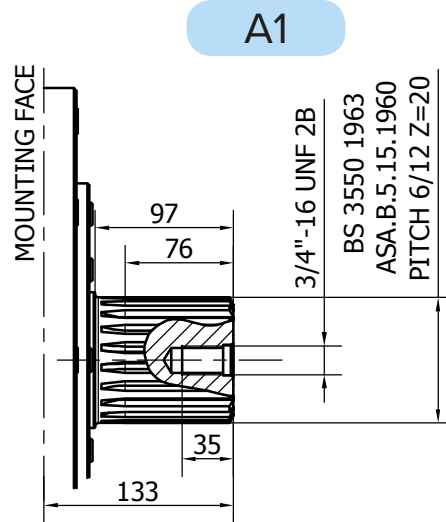

Available spline billet: SB10

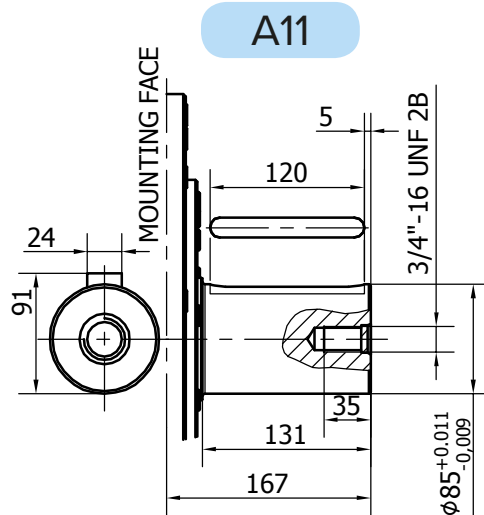

R8M H55/C

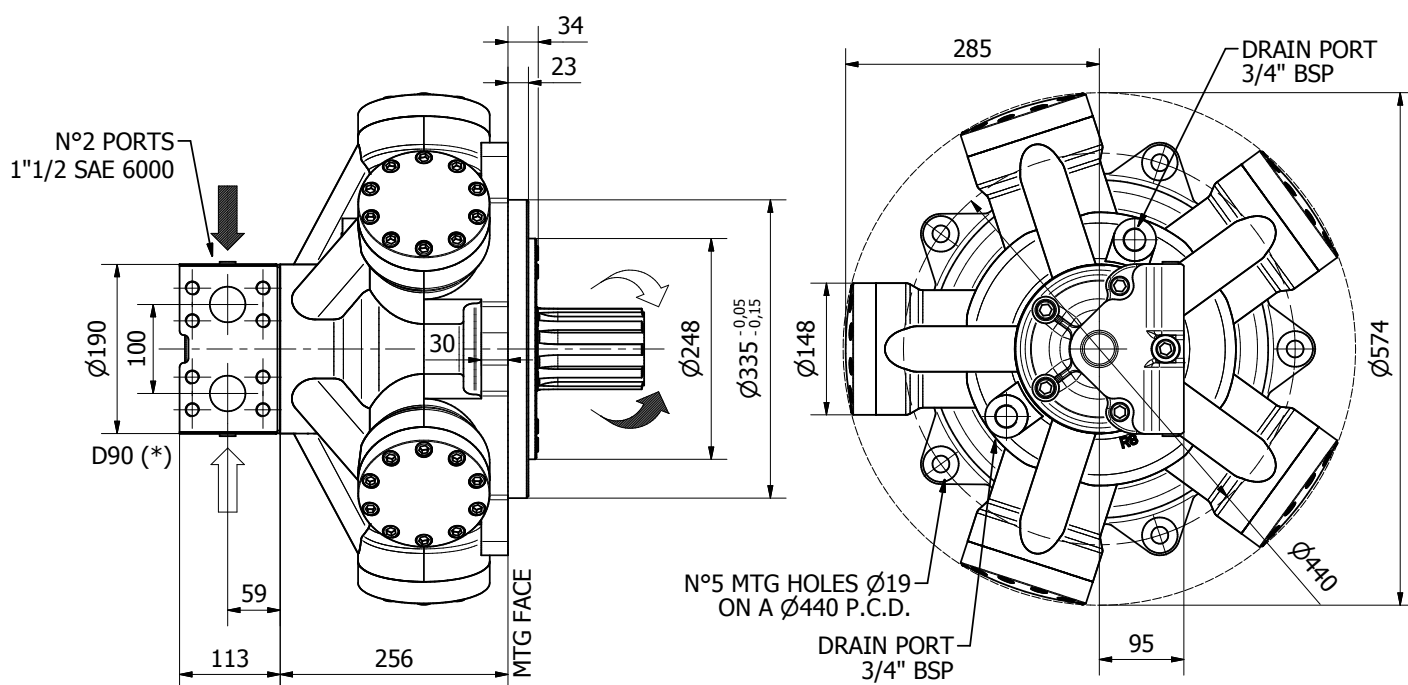

Available distributor flange: **FL10**

For S04, refer to page 190-191
(distributor fitting D75)

TECHNICAL DATA

		2200	2500	2800	3000
DISPLACEMENT	[cc]	2126	2525	2807	2983
SPECIFIC TORQUE	[Nm/bar]	33.8	40.2	44.7	48.2
MAX. CONT. PRESSURE	[bar]	270	270	260	260
HYDROSTATIC TEST PRESSURE	[bar]	420	420	420	420
MAX. CONT. SPEED	[rpm]	240	240	240	230
PEAK SPEED (***)	[rpm]	280	280	280	270
MAX. CONT. POWER (****)	[kW]	120	120	120	120
MAX. POWER	[kW]	170	170	170	170
MAX. CASE PRESSURE	[bar]	6	6	6	6
DRY WEIGHT	[kg]	203	203	203	203
TEMPERATURE RANGE (**)	[°C]	-30÷70	-30÷70	-30÷70	-30÷70

- (*) The standard distributor (D90) is shown. Please refer to distributors section (pag. 178-179) for different distributor interfaces.

- (**) Please refer to the hydraulic fluid recommendations (pag. 10-11).

- (***) Do not exceed maximum power.

- (****) For motor operation with a continuous duty cycle at maximum continuous power the flushing is usually required (see pag. 13). For more information please contact our technical department.

SHAFTS

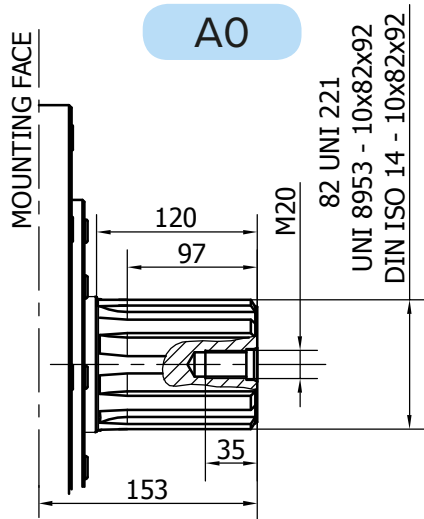

Available spline billet: SB9

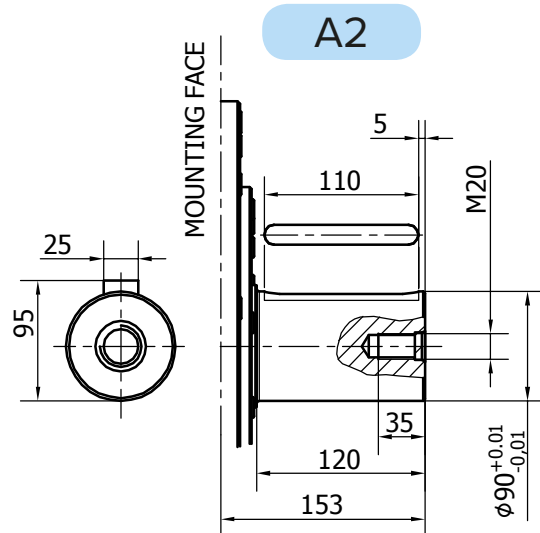

R8M H55 - PERFORMANCE CURVES

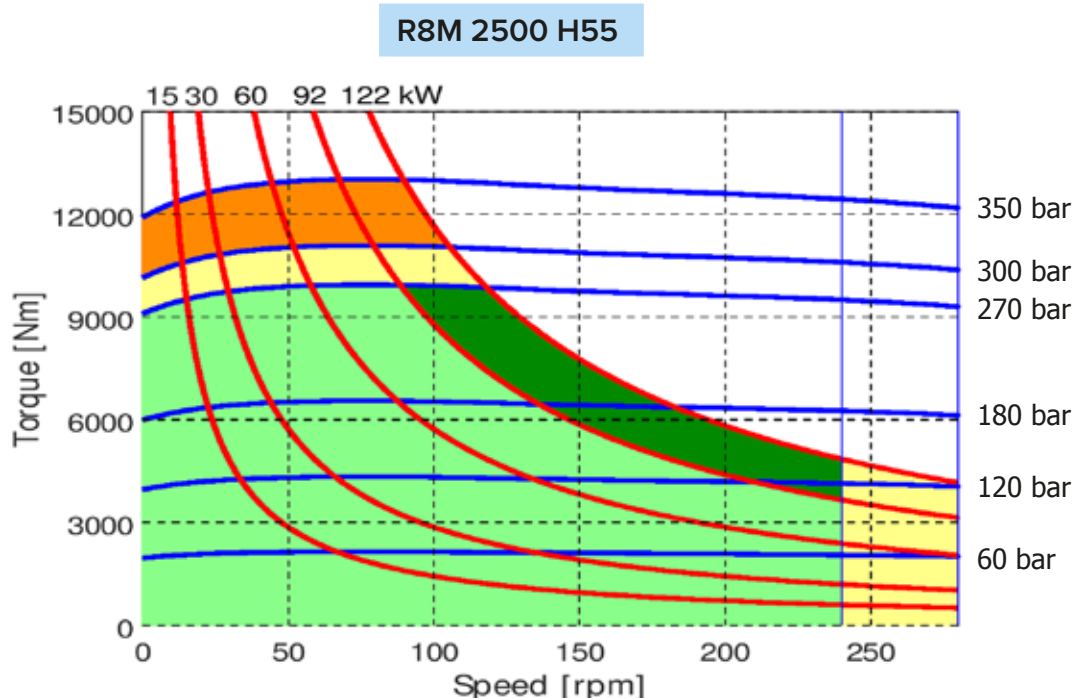
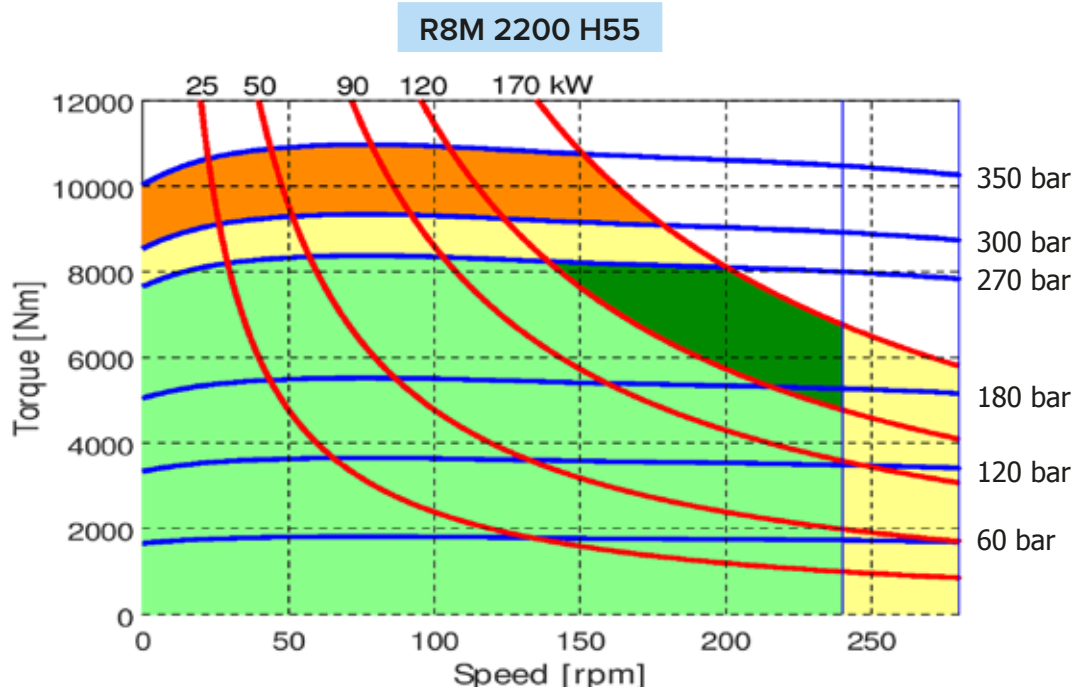

- Continuous operation
- Continuous operation with flushing or intermittent operation (see below for intermittent operation)
- Intermittent operation: permitted for a 15% of duty cycle, for 3 minutes maximum period
- Peak operation: permitted for very short periods (3-5 seconds every 10-15 minutes)

The above diagrams are referring to the hydraulic motor working with a fluid in ideal conditions (viscosity at 40 cSt). In case the working temperature increases and viscosity reach values under the recommended values (see hydraulic fluid recommendations) flushing must be performed or ISO oil grade must be changed. The working temperature must not overcome 70 °C.

R8M 2800 H55

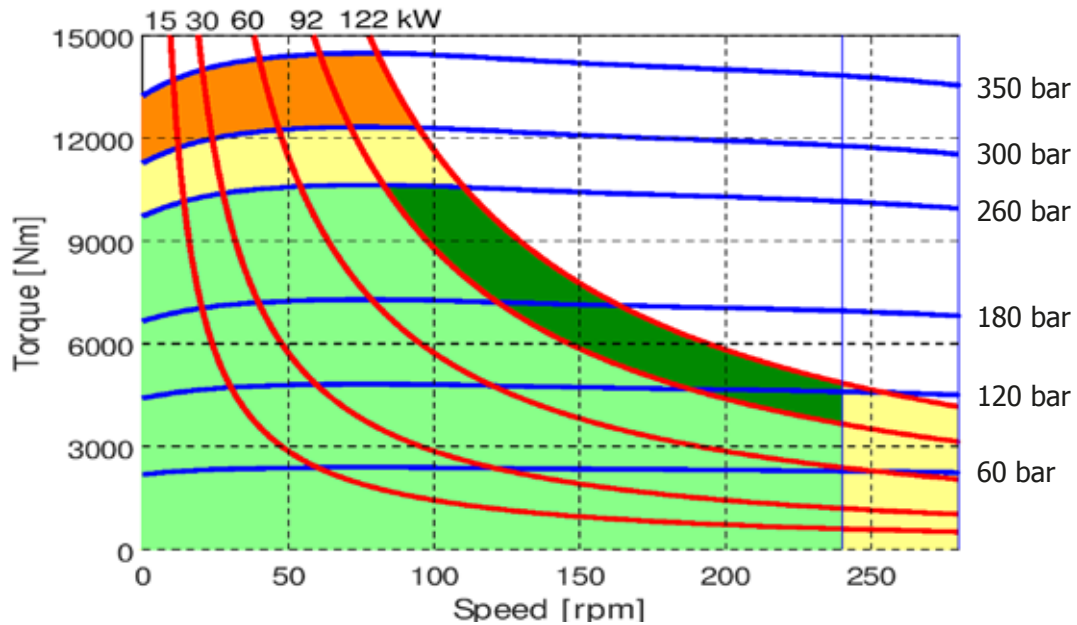

R8M 3000 H55

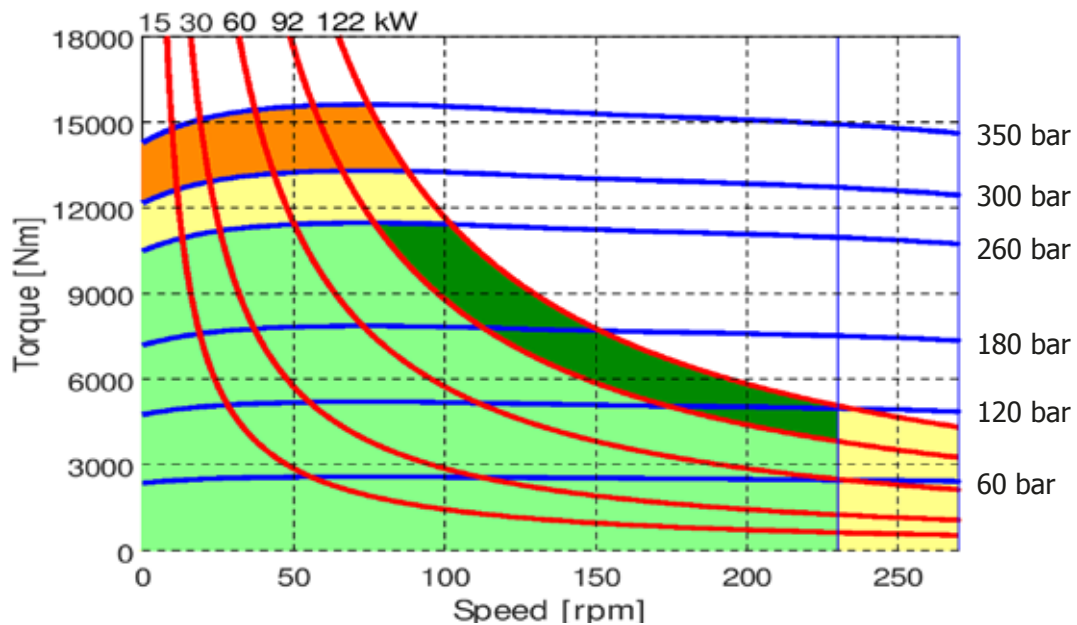

- Continuous operation
- Continuous operation with flushing or intermittent operation (see below for intermittent operation)
- Intermittent operation: permitted for a 15% of duty cycle, for 3 minutes maximum period
- Peak operation: permitted for very short periods (3-5 seconds every 10-15 minutes)

The above diagrams are referring to the hydraulic motor working with a fluid in ideal conditions (viscosity at 40 cSt). In case the working temperature increases and viscosity reach values under the recommended values (see hydraulic fluid recommendations) flushing must be performed or ISO oil grade must be changed. The working temperature must not overcome 70 °C.

R8M H55 - PERFORMANCE CURVES

BEARING LIFE

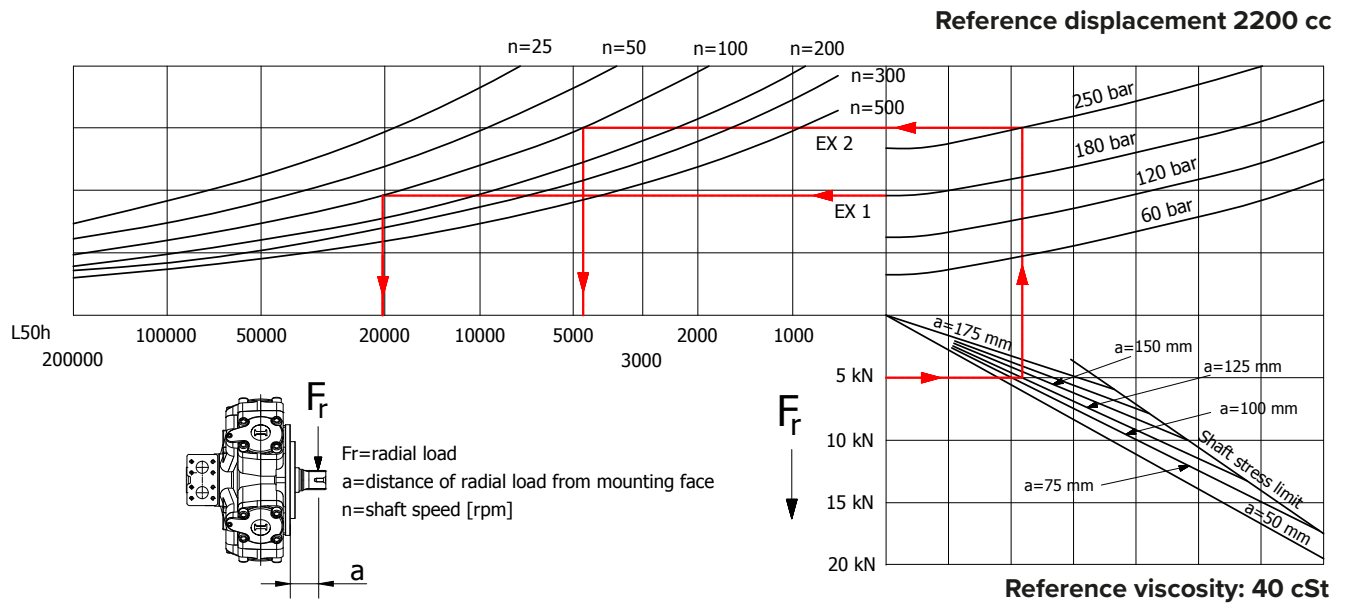

Example:

We suppose (EX1): $p=180$ [bar], $n=100$ [rpm]; we obtain an average lifetime of 33000 [h].

If we suppose (EX2): $F_r=20$ [kN], $a=100$ [mm], $n=100$ [rpm] and $p=250$ [bar] we obtain an average lifetime of 11000 [h].

The above data are referring to the R8M H55 series motors, displacement 2200 cc.

R8M H55 - ORDERING CODE

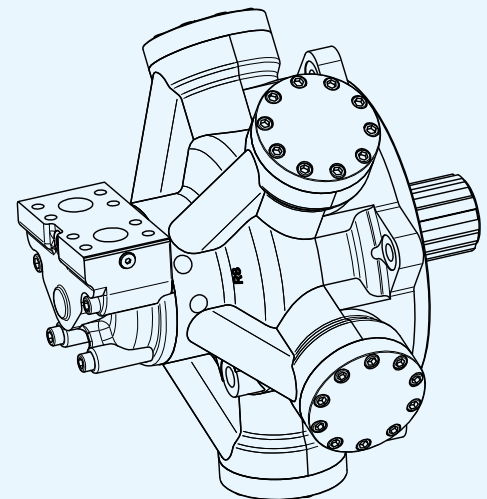
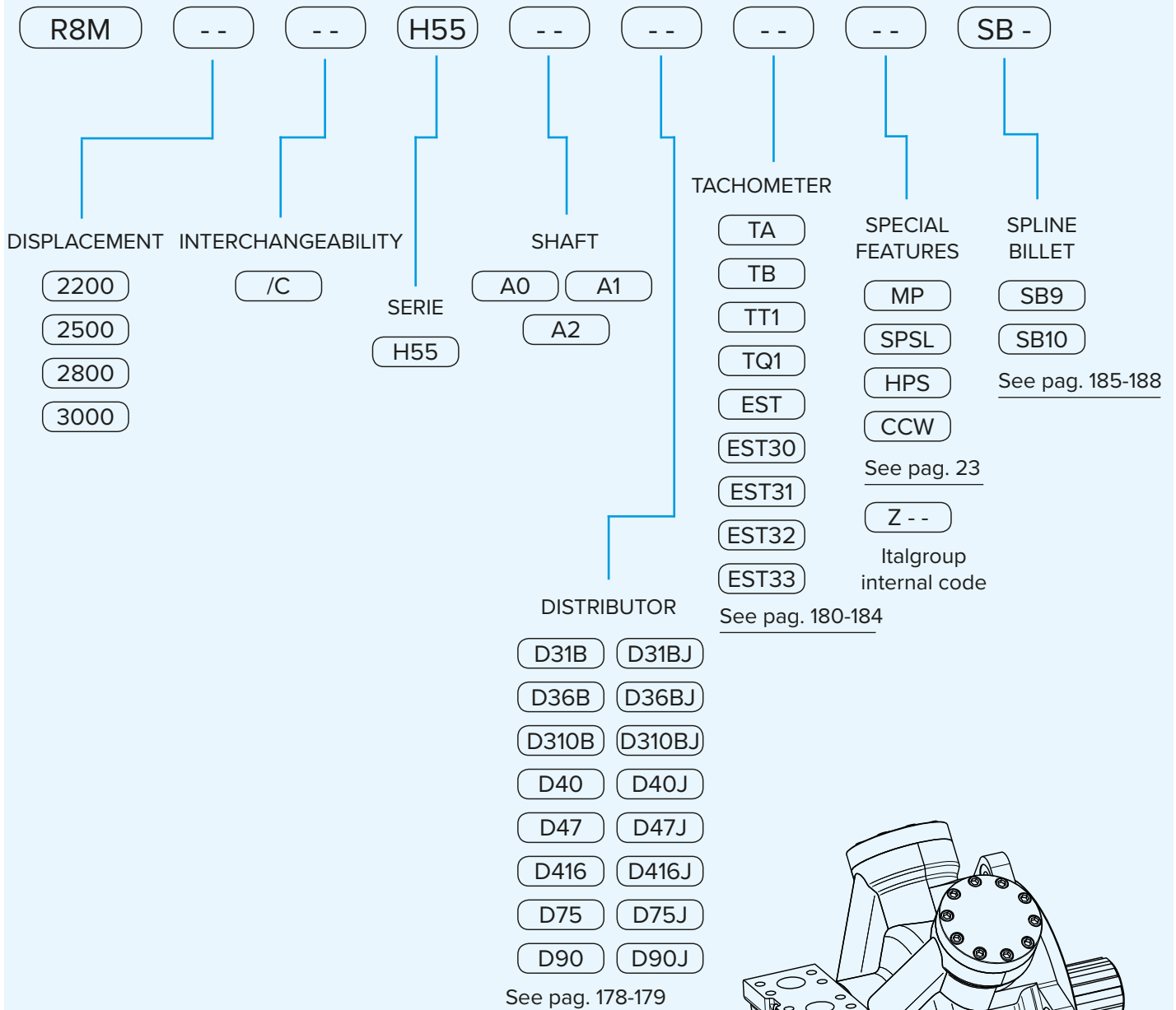

EXAMPLES:

- R8M 2500 H55 A1 D90 SB10
- R8M 2200/C H55 A0 D75 SB9
- R8M 3000 H55 A2 D90

R8M H6

R8M H6	Pag. 152 - 153
R8M H6/C	Pag. 154 - 155
R8M 2200/B125-2500/B150-3000/B200 H6	Pag. 156 - 157
R8M H6 - PERFORMANCE CURVES	Pag. 158 - 161
R8M H6 - ORDERING CODE	Pag. 162

SHAFTS

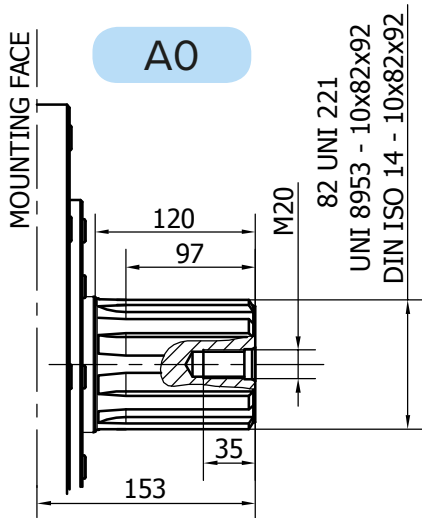

Available spline billet: SB9

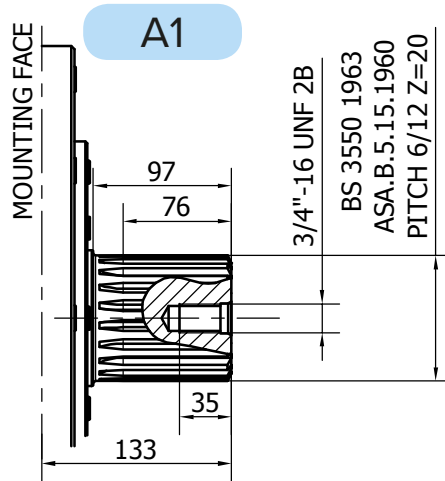

Available spline billet: SB10

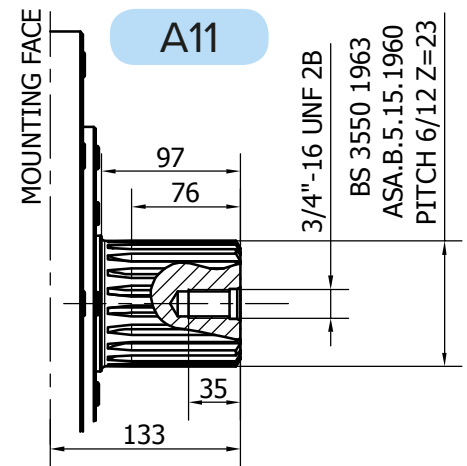

Available spline billet: SB24

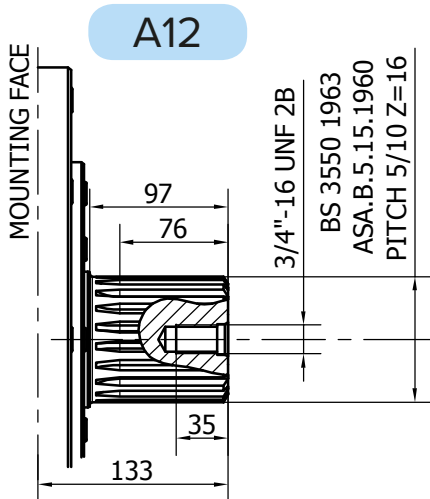

Available spline billet: SB27

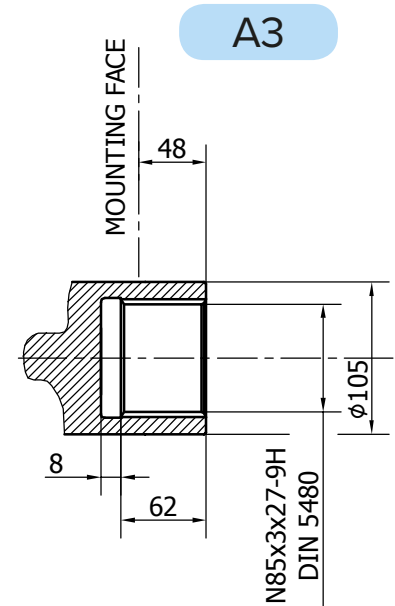
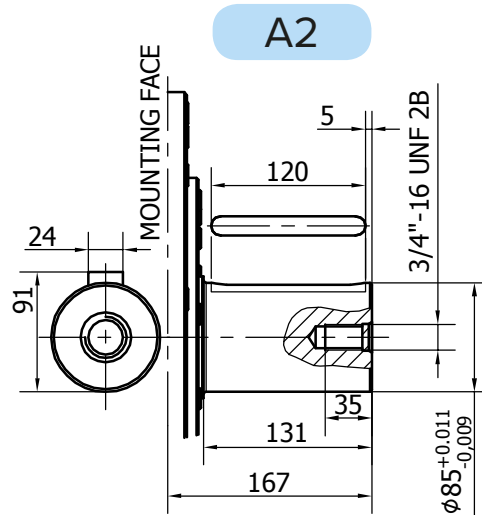

R8M H6/C

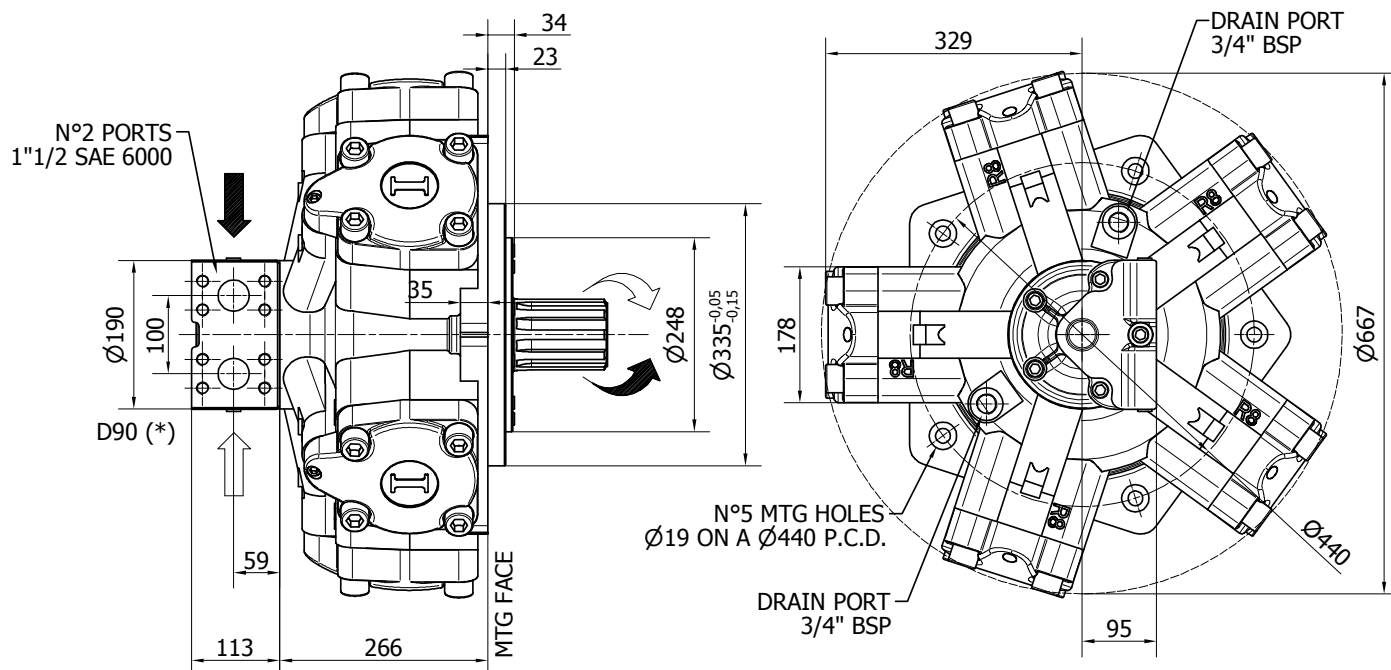

Available distributor flange: **FL10**

For S04, refer to page 190-191
(distributor fitting D75)

TECHNICAL DATA

		2200	2500	2800	3000	3200	3500
DISPLACEMENT	[cc]	2206	2525	2807	2983	3289	3479
SPECIFIC TORQUE	[Nm/bar]	35.1	40.2	44.7	47.5	52.3	55.4
MAX. CONT. PRESSURE	[bar]	270	270	270	270	260	250
HYDROSTATIC TEST PRESSURE	[bar]	420	420	420	420	420	420
MAX. CONT. SPEED	[rpm]	220	220	220	210	200	200
PEAK SPEED (***)	[rpm]	260	260	260	250	240	240
MAX. CONT. POWER (****)	[kW]	122	122	122	122	122	122
MAX. POWER	[kW]	172	172	172	172	172	172
MAX. CASE PRESSURE	[bar]	6	6	6	6	6	6
DRY WEIGHT	[kg]	308	308	308	308	308	308
TEMPERATURE RANGE (**)	[°C]	-30÷70	-30÷70	-30÷70	-30÷70	-30÷70	-30÷70

- (*) The standard distributor (D90) is shown. Please refer to distributors section (pag. 178-179) for different distributor interfaces.

- (**) Please refer to the hydraulic fluid recommendations (pag. 10-11).

- (***) Do not exceed maximum power.

- (****) For motor operation with a continuous duty cycle at maximum continuous power the flushing is usually required (see pag. 13). For more information please contact our technical department.

SHAFTS

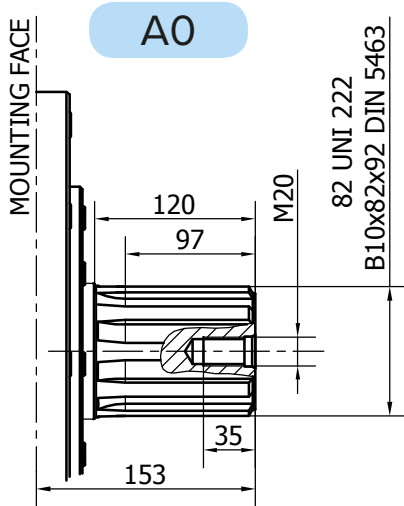

Available spline billet: SB9

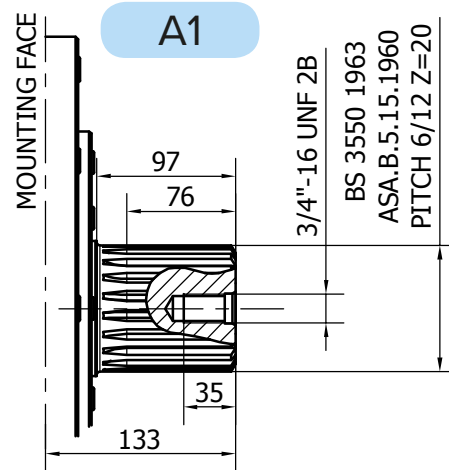

Available spline billet: SB10

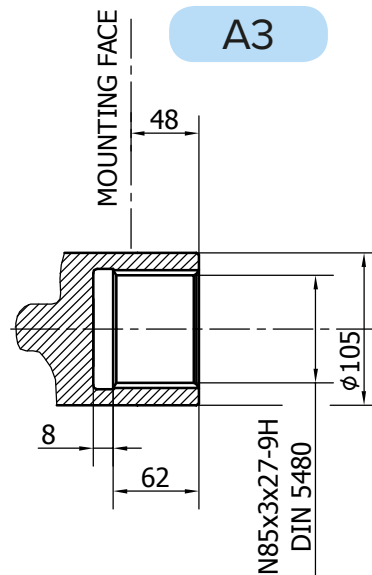
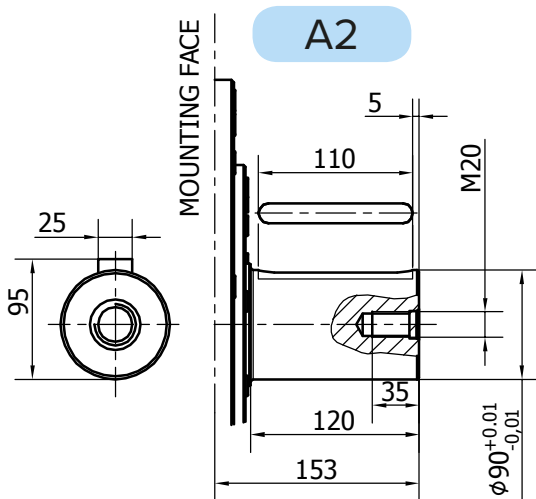

SHAFTS

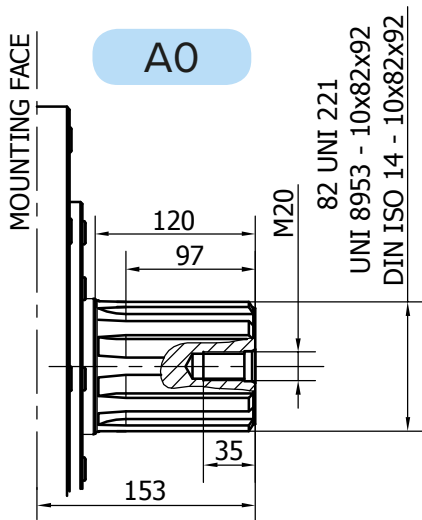

Available spline billet: SB9

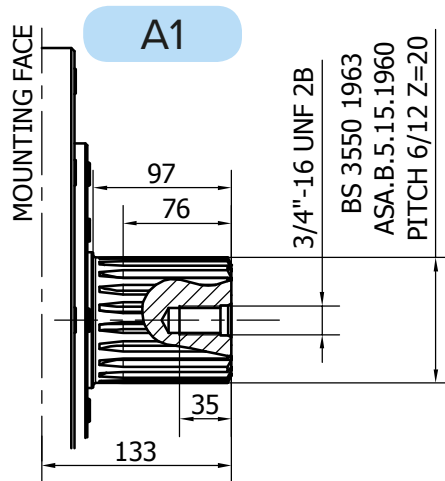

Available spline billet: SB10

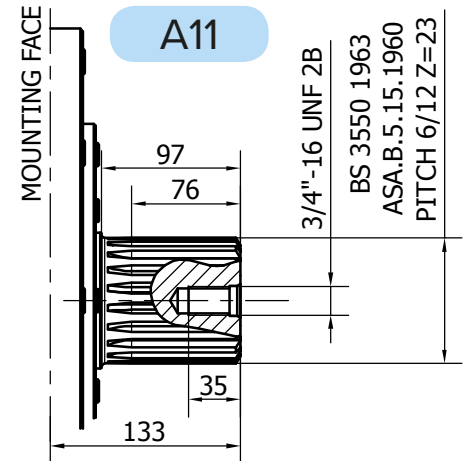

Available spline billet: SB24

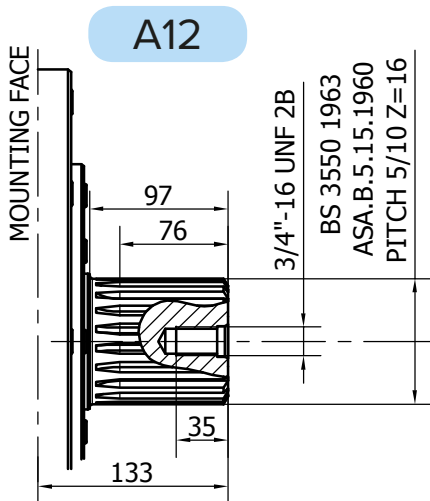

Available spline billet: SB27

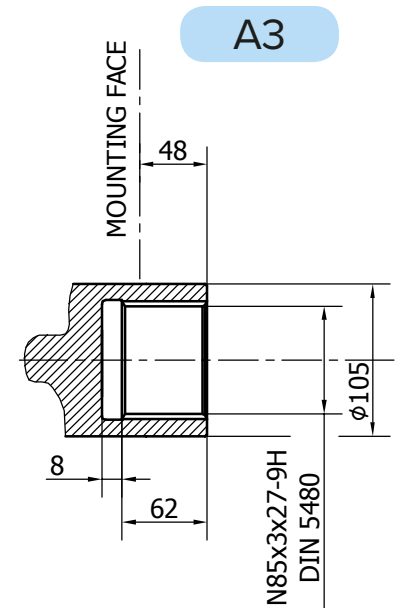
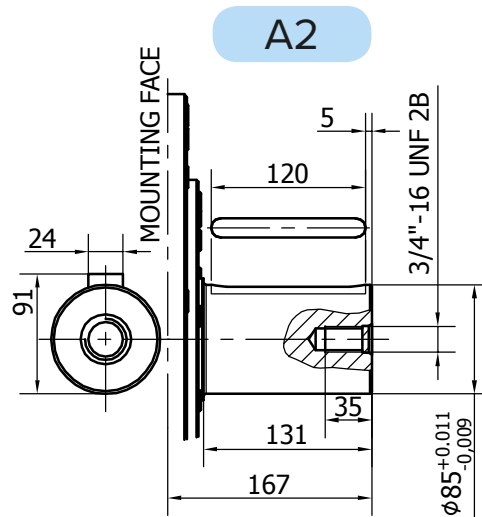

R8M H6 - PERFORMANCE CURVES

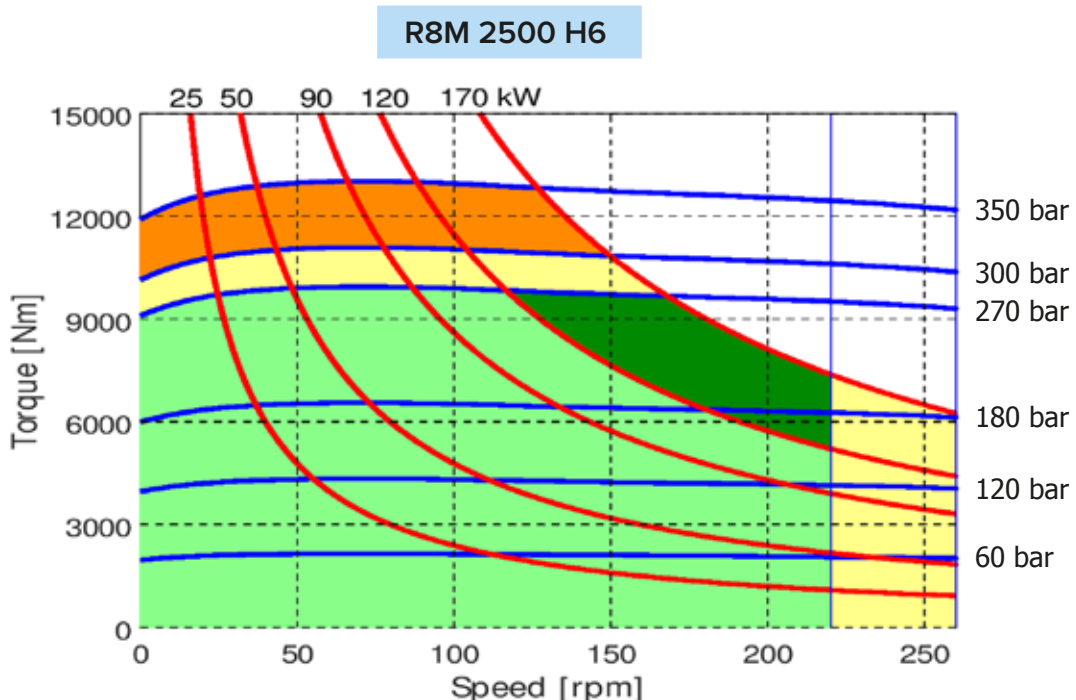
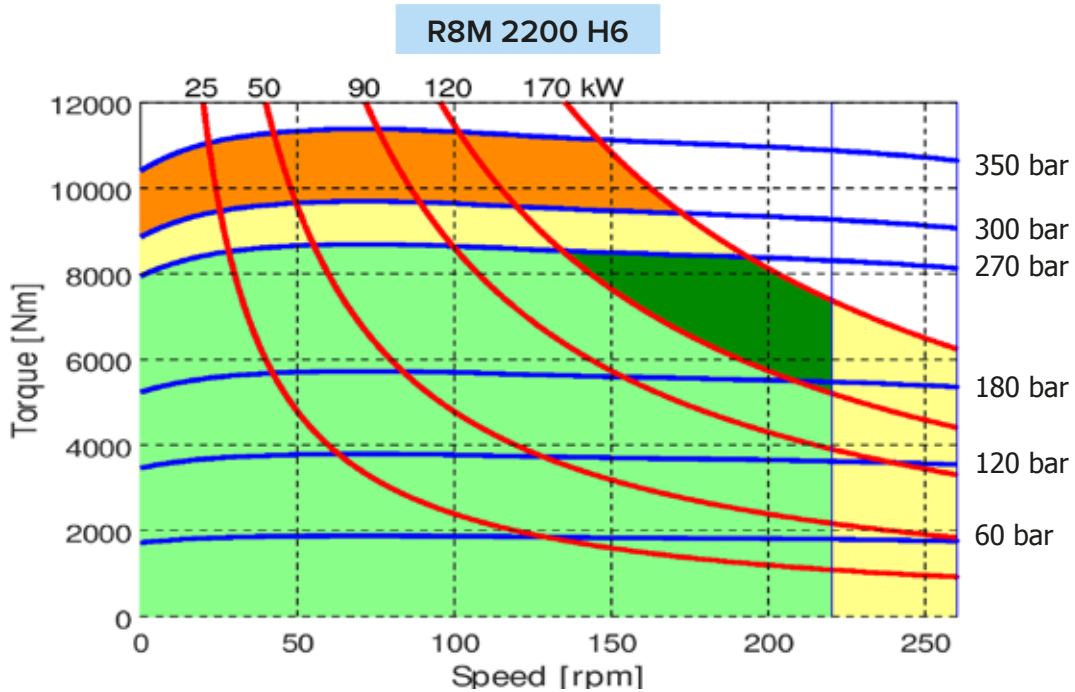

- Continuous operation
- Continuous operation with flushing or intermittent operation (see below for intermittent operation)
- Intermittent operation: permitted for a 15% of duty cycle, for 3 minutes maximum period
- Peak operation: permitted for very short periods (3-5 seconds every 10-15 minutes)

The above diagrams are referring to the hydraulic motor working with a fluid in ideal conditions (viscosity at 40 cSt). In case the working temperature increases and viscosity reach values under the recommended values (see hydraulic fluid recommendations) flushing must be performed or ISO oil grade must be changed. The working temperature must not overcome 70 °C.

R8M 2800 H6

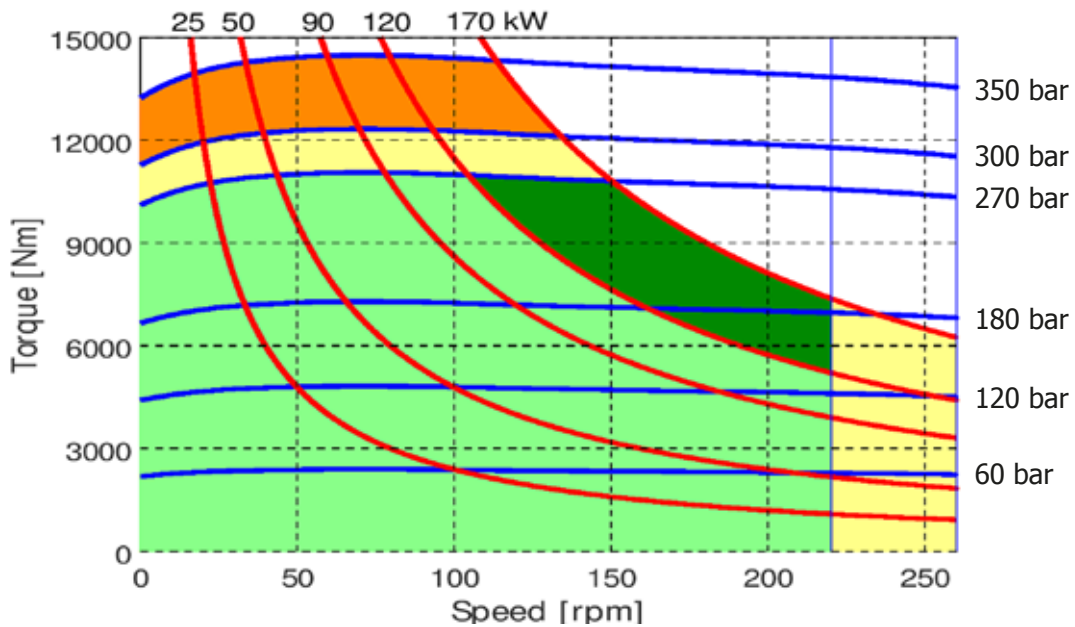

R8M 3000 H6

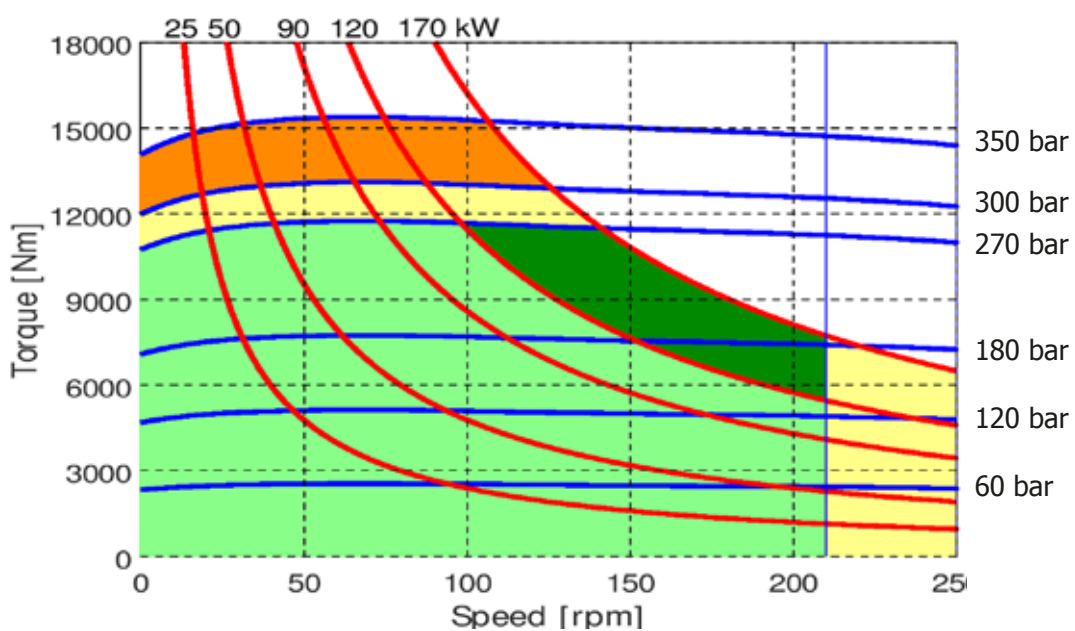

- Continuous operation
- Continuous operation with flushing or intermittent operation (see below for intermittent operation)
- Intermittent operation: permitted for a 15% of duty cycle, for 3 minutes maximum period
- Peak operation: permitted for very short periods (3-5 seconds every 10-15 minutes)

The above diagrams are referring to the hydraulic motor working with a fluid in ideal conditions (viscosity at 40 cSt). In case the working temperature increases and viscosity reach values under the recommended values (see hydraulic fluid recommendations) flushing must be performed or ISO oil grade must be changed. The working temperature must not overcome 70 °C.

R8M H6 - PERFORMANCE CURVES

R8M 3200 H6

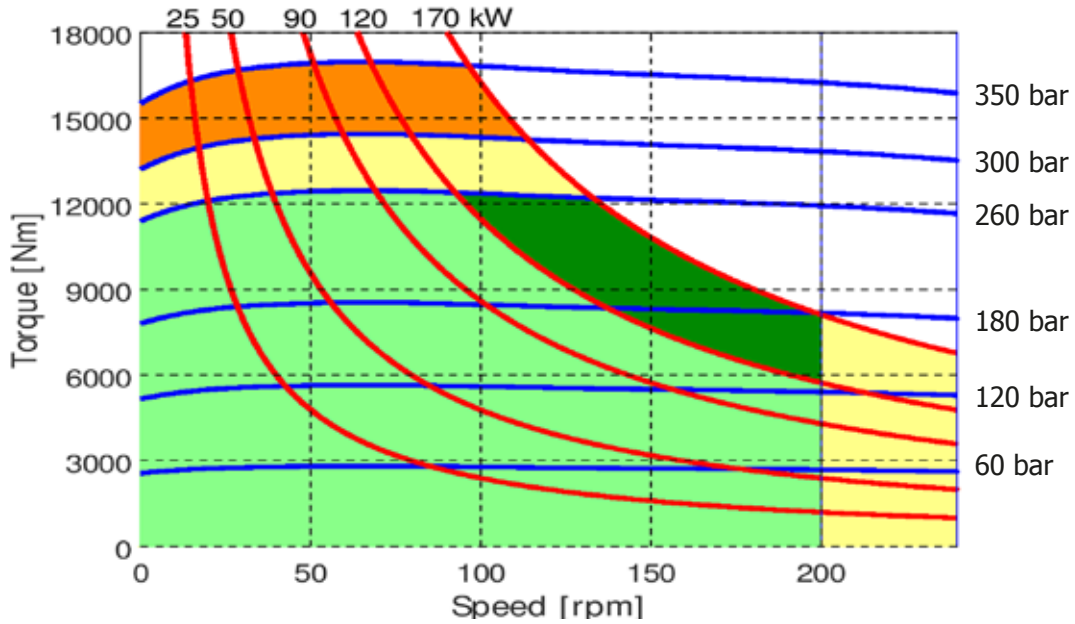

R8M 3500 H6

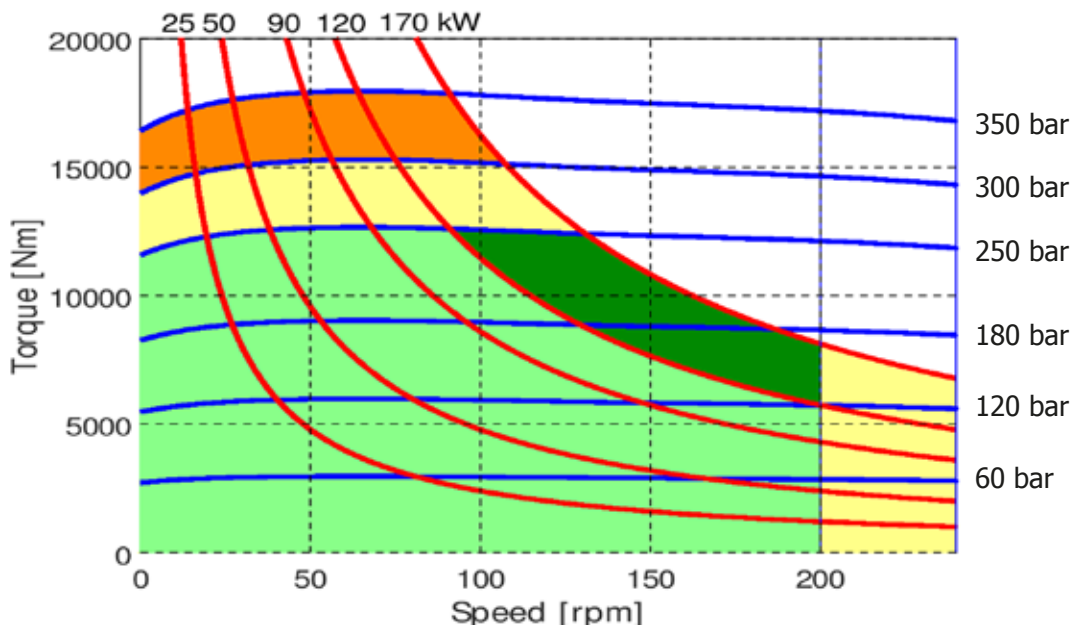

- Continuous operation
- Continuous operation with flushing or intermittent operation (see below for intermittent operation)
- Intermittent operation: permitted for a 15% of duty cycle, for 3 minutes maximum period
- Peak operation: permitted for very short periods (3-5 seconds every 10-15 minutes)

The above diagrams are referring to the hydraulic motor working with a fluid in ideal conditions (viscosity at 40 cSt). In case the working temperature increases and viscosity reach values under the recommended values (see hydraulic fluid recommendations) flushing must be performed or ISO oil grade must be changed. The working temperature must not overcome 70 °C.

R8M H6 - BEARING LIFE

BEARING LIFE

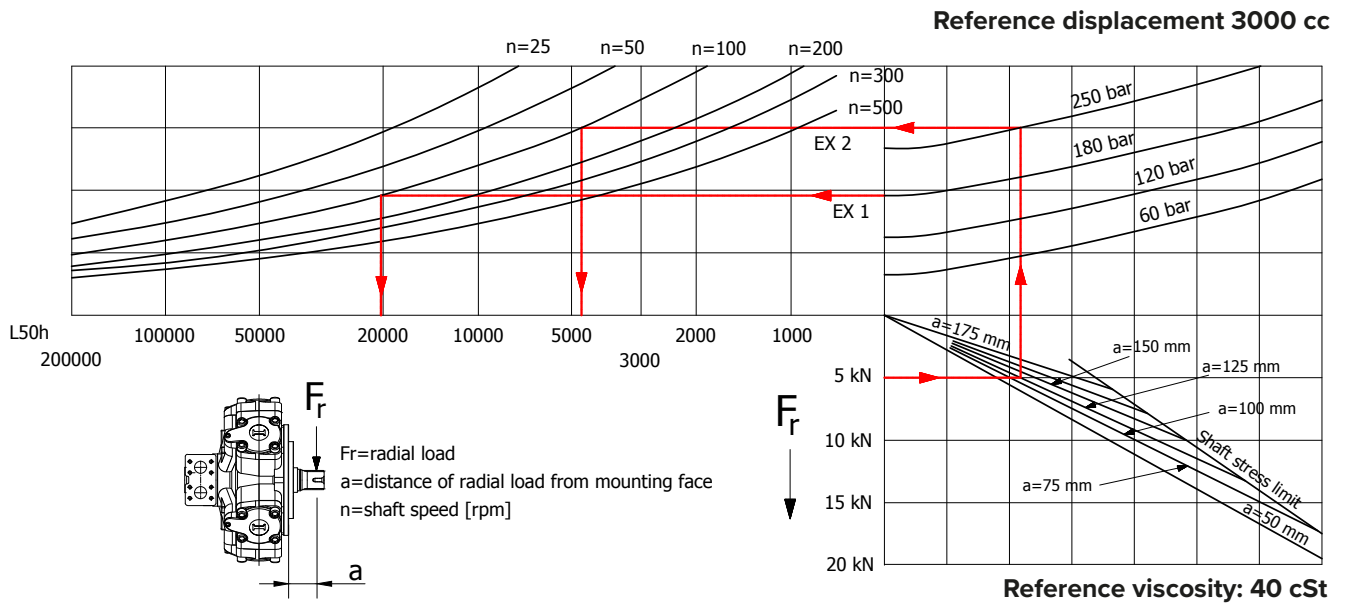

Example:

We suppose (EX1): $p=120$ [bar], $n=300$ [rpm]; we obtain an average lifetime of 34000 [h].

If we suppose (EX2): $F_r=20$ [kN], $a=100$ [mm], $n=50$ [rpm] and $p=250$ [bar] we obtain an average lifetime of 13000 [h].

The above data are referring to the R8M H6 series motors, displacement 3000 cc.

R8M H6 - ORDERING CODE

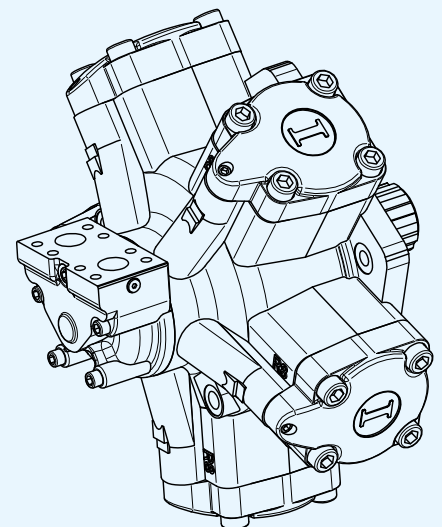
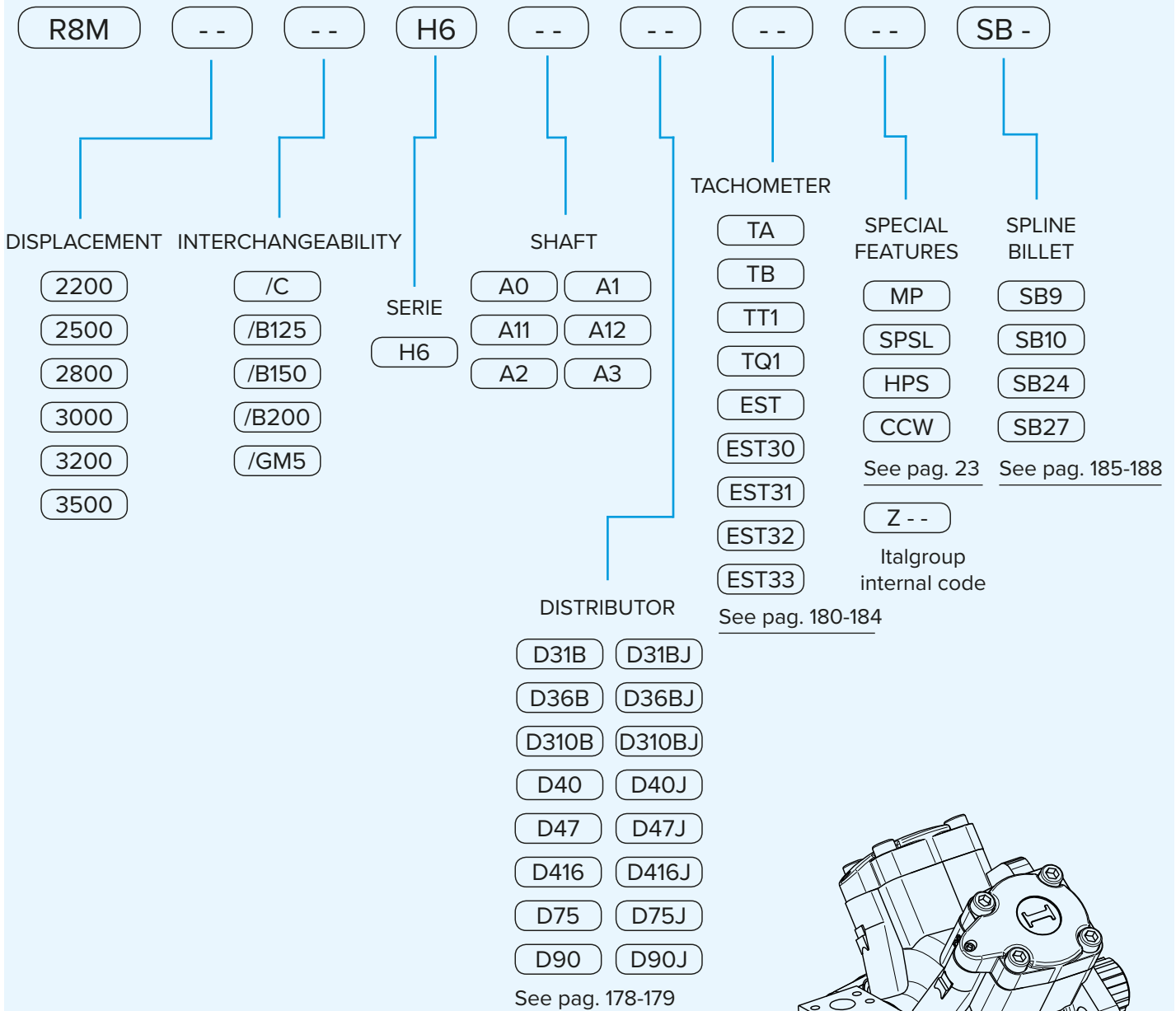

EXAMPLES:

R8M 2200 H6 A1 D90J
 R8M 3000 H6 A0 D90 SB9
 R8M 2500/C H6 A0 D90J CCW SB9

R8M H7

R8M H7	Pag. 164 - 167
R8M H7/C	Pag. 168 - 169
R8M H7/RM	Pag. 170 - 171
R8M H7 - PERFORMANCE CURVES	Pag. 172 - 176
R8M H7 - ORDERING CODE	Pag. 177

R8M H7

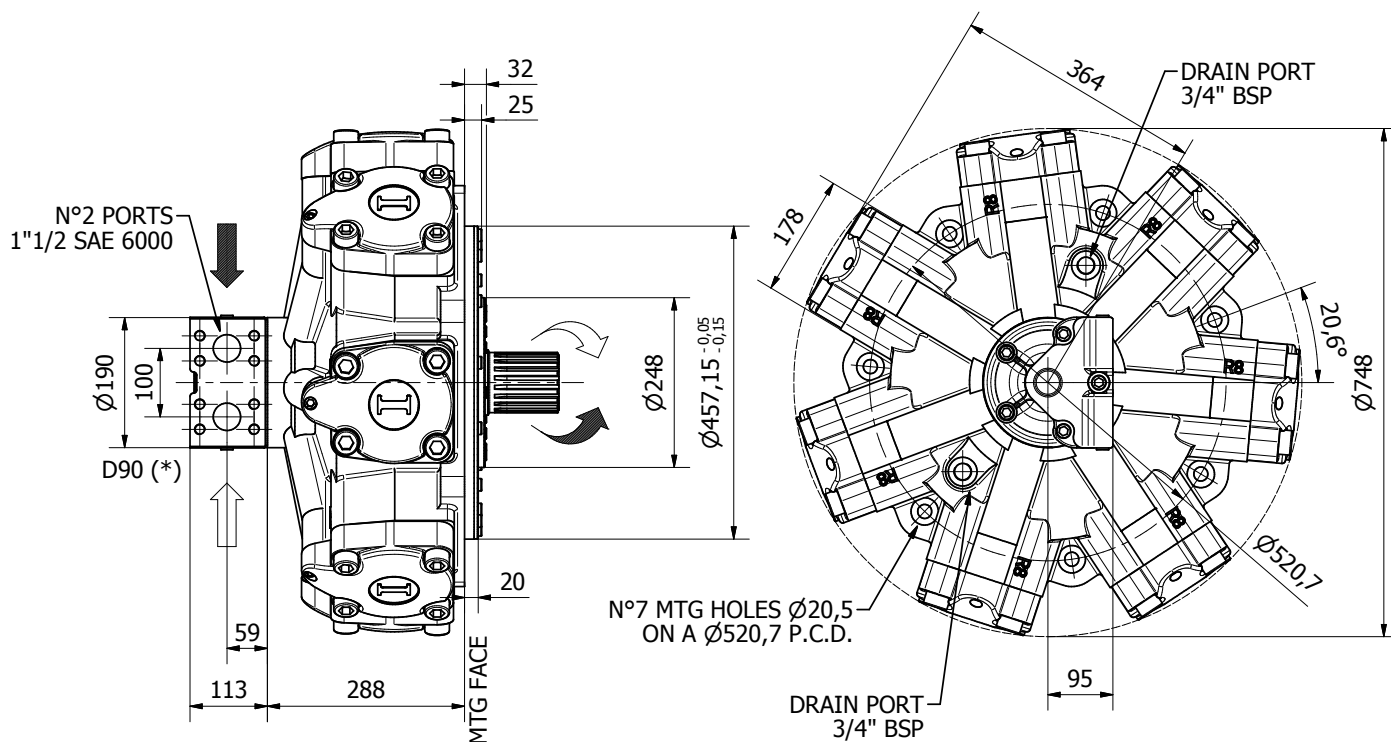

Available distributor flange: **FL16**

For S04, refer to page 190-191
(distributor fitting D90)

TECHNICAL DATA

		3400	3600	3900	4300	4600	5000	5400
DISPLACEMENT	[cc]	3413	3650	3907	4343	4616	5088	5384
SPECIFIC TORQUE	[Nm/bar]	54.3	58.1	62.2	69.1	73.5	81.0	85.7
MAX. CONT. PRESSURE	[bar]	270	270	270	270	270	260	250
HYDROSTATIC TEST PRESSURE	[bar]	420	420	420	420	420	420	420
MAX. CONT. SPEED	[rpm]	180	170	160	150	140	140	130
PEAK SPEED (***)	[rpm]	220	200	200	190	190	180	170
MAX. CONT. POWER (****)	[kW]	132	132	132	132	132	132	132
MAX. POWER	[kW]	182	182	182	182	182	182	182
MAX. CASE PRESSURE	[bar]	6	6	6	6	6	6	6
DRY WEIGHT	[kg]	405	405	405	405	405	405	405
TEMPERATURE RANGE (**)	[°C]	-30÷70	-30÷70	-30÷70	-30÷70	-30÷70	-30÷70	-30÷70

- (*) The standard distributor (D90) is shown. Please refer to distributors section (pag. 178-179) for different distributor interfaces.

- (**) Please refer to the hydraulic fluid recommendations (pag. 10-11).

- (***) Do not exceed maximum power.

- (****) For motor operation with a continuous duty cycle at maximum continuous power the flushing is usually required (see pag. 13). For more information please contact our technical department.

SHAFTS

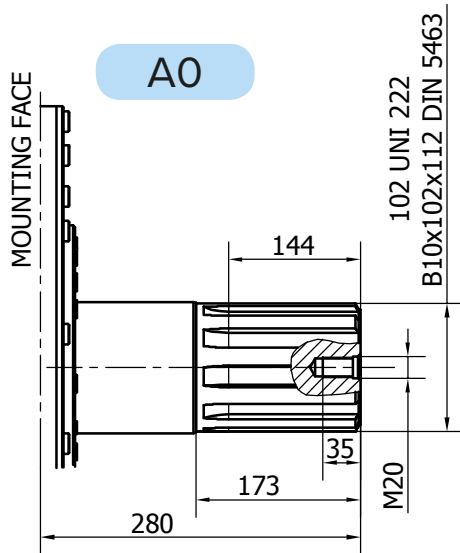

Available spline billet: SB11

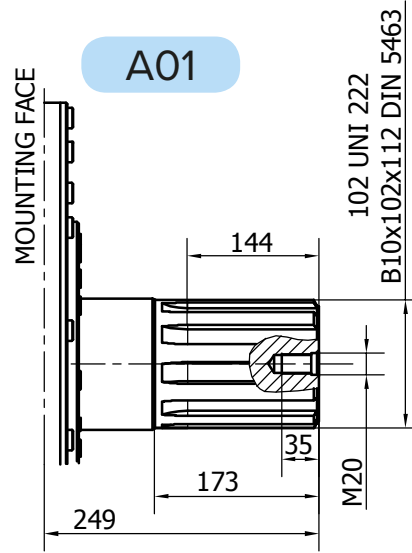

Available spline billet: SB11

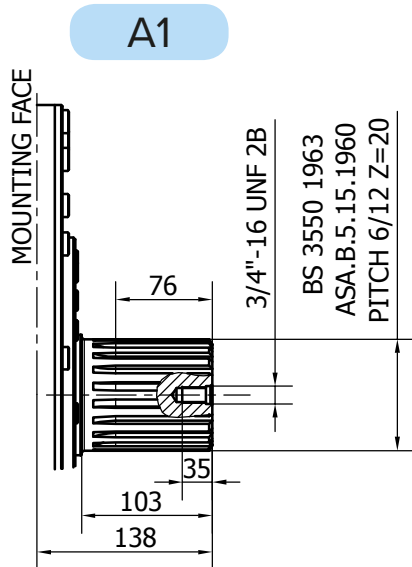

Available spline billet: SB10

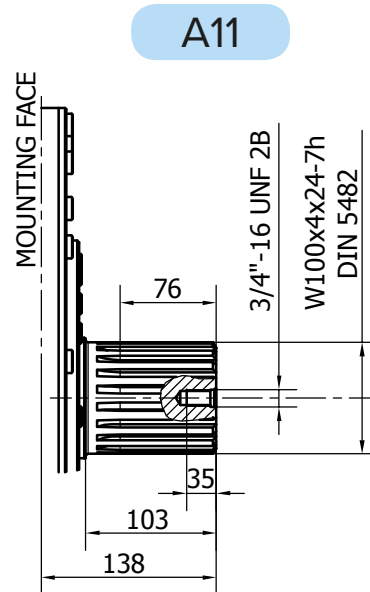

R8M H7

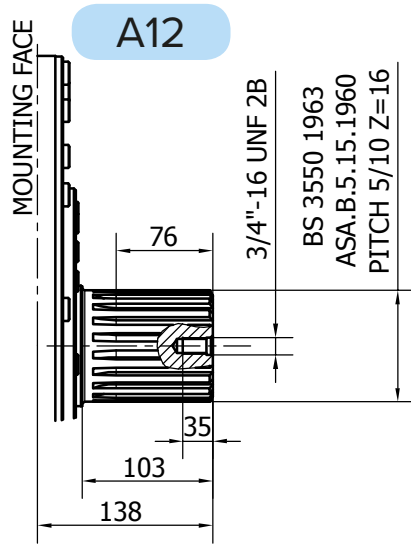

Available spline billet: SB27

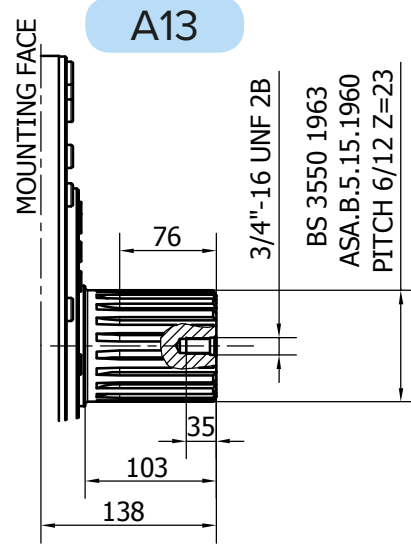

Available spline billet: SB24

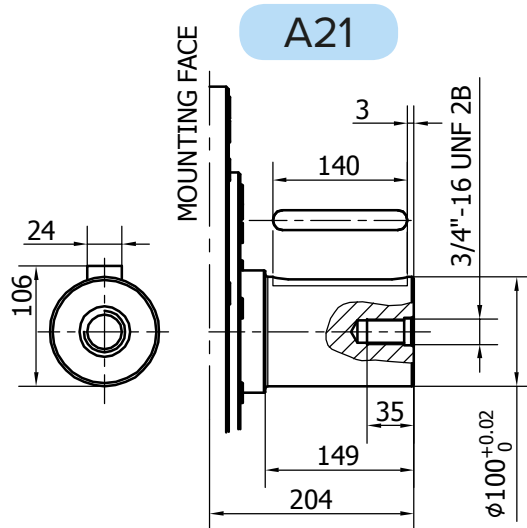
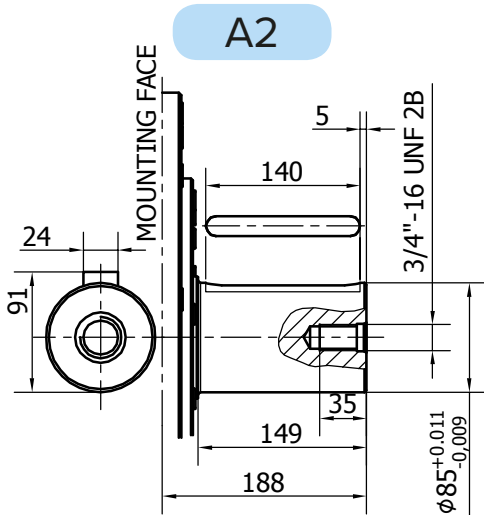

SHAFTS

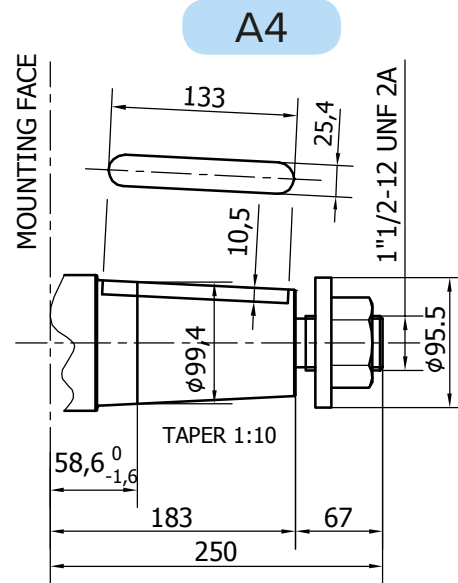
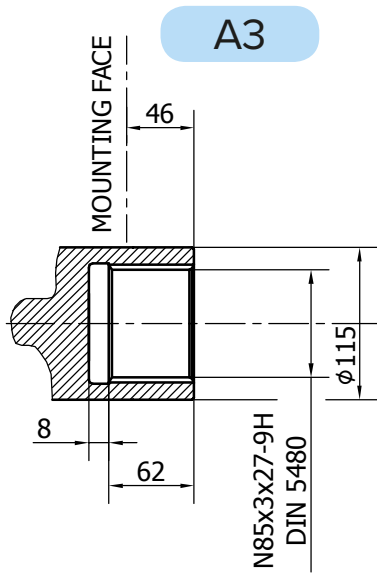

SHAFTS

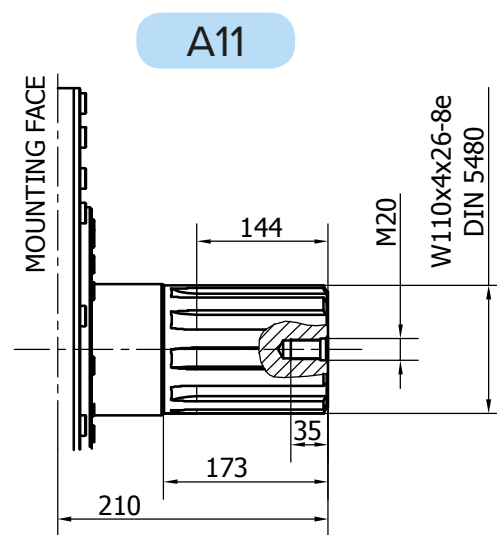
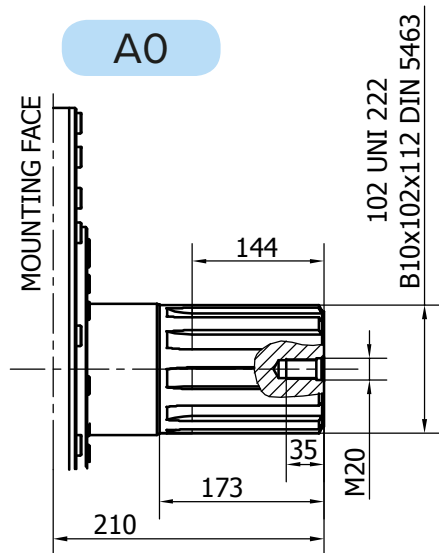

Available spline billet: SB11

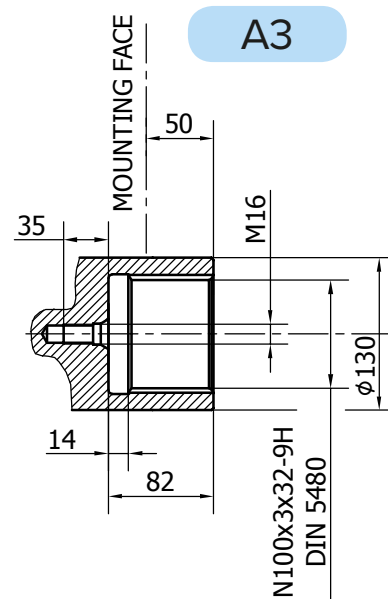
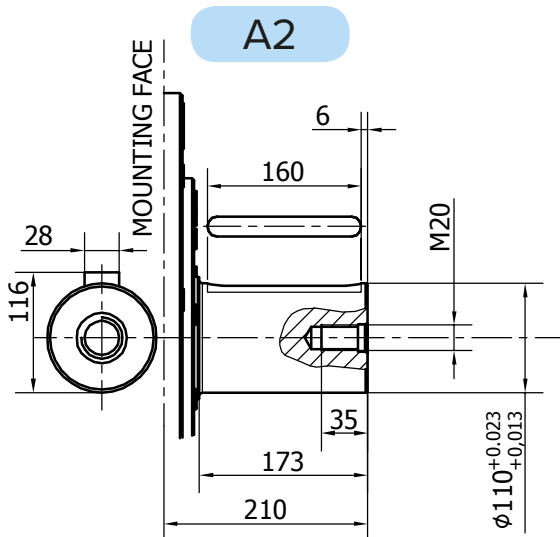

R8M H7/RM

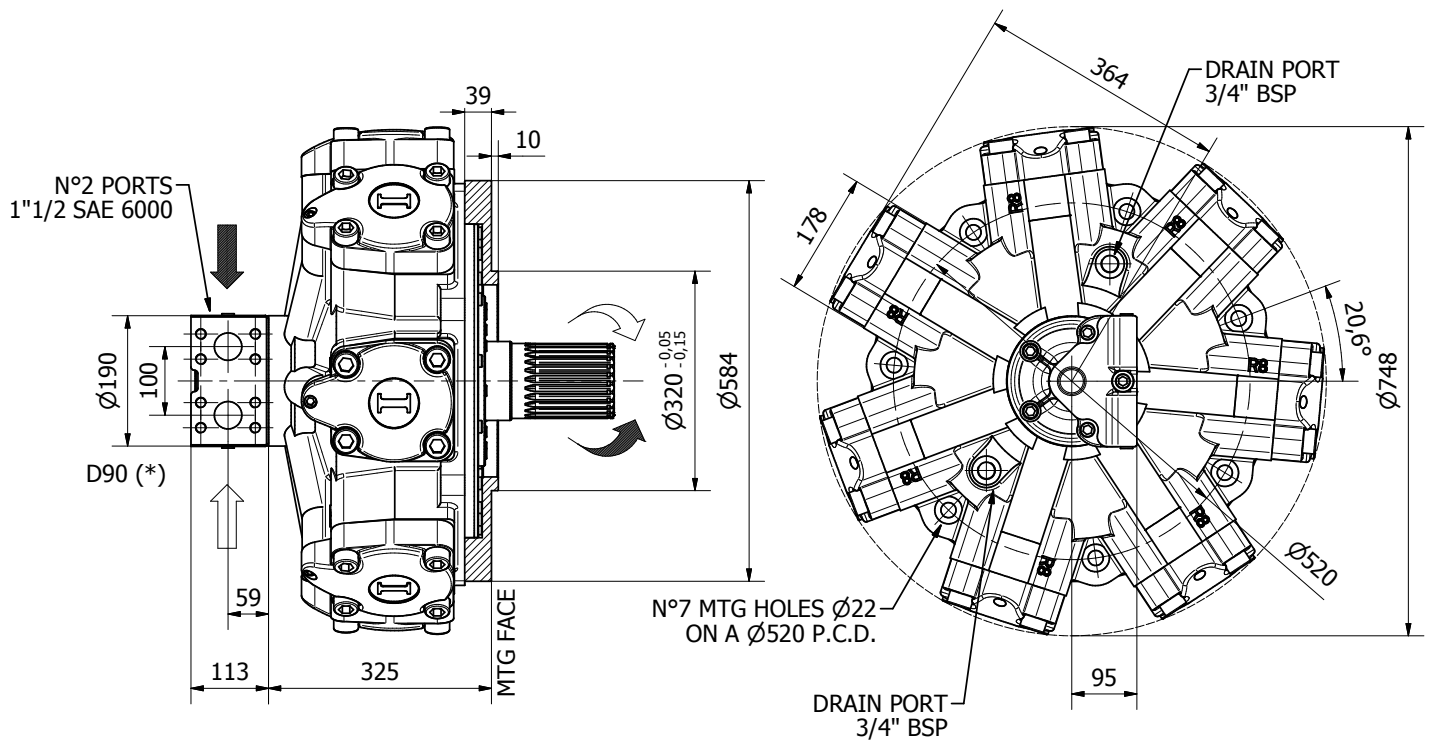

TECHNICAL DATA

		3400	3600	3900	4300	4600	5000	5400
DISPLACEMENT	[cc]	3413	3650	3907	4343	4616	5088	5384
SPECIFIC TORQUE	[Nm/bar]	54.3	58.1	62.2	69.1	73.5	81.0	85.7
MAX. CONT. PRESSURE	[bar]	270	270	270	270	270	260	250
HYDROSTATIC TEST PRESSURE	[bar]	420	420	420	420	420	420	420
MAX. CONT. SPEED	[rpm]	180	170	160	150	140	140	130
PEAK SPEED (***)	[rpm]	220	200	200	190	190	180	170
MAX. CONT. POWER (****)	[kW]	132	132	132	132	132	132	132
MAX. POWER	[kW]	182	182	182	182	182	182	182
MAX. CASE PRESSURE	[bar]	6	6	6	6	6	6	6
DRY WEIGHT	[kg]	405	405	405	405	405	405	405
TEMPERATURE RANGE (**)	[°C]	-30÷70	-30÷70	-30÷70	-30÷70	-30÷70	-30÷70	-30÷70

- (*) The standard distributor (D90) is shown. Please refer to distributors section (pag. 178-179) for different distributor interfaces.

- (**) Please refer to the hydraulic fluid recommendations (pag. 10-11).

- (***) Do not exceed maximum power.

- (****) For motor operation with a continuous duty cycle at maximum continuous power the flushing is usually required (see pag. 13). For more information please contact our technical department.

SHAFTS

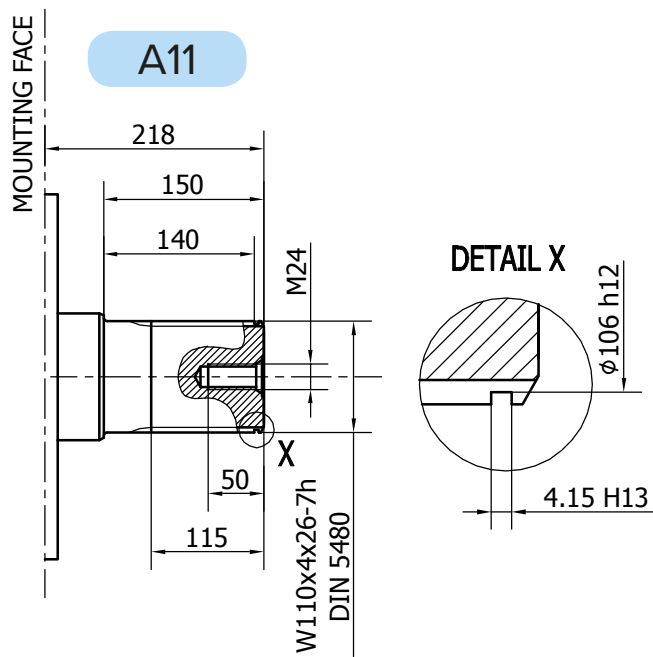

R8M H7 - PERFORMANCE CURVES

R8M 3400 H7

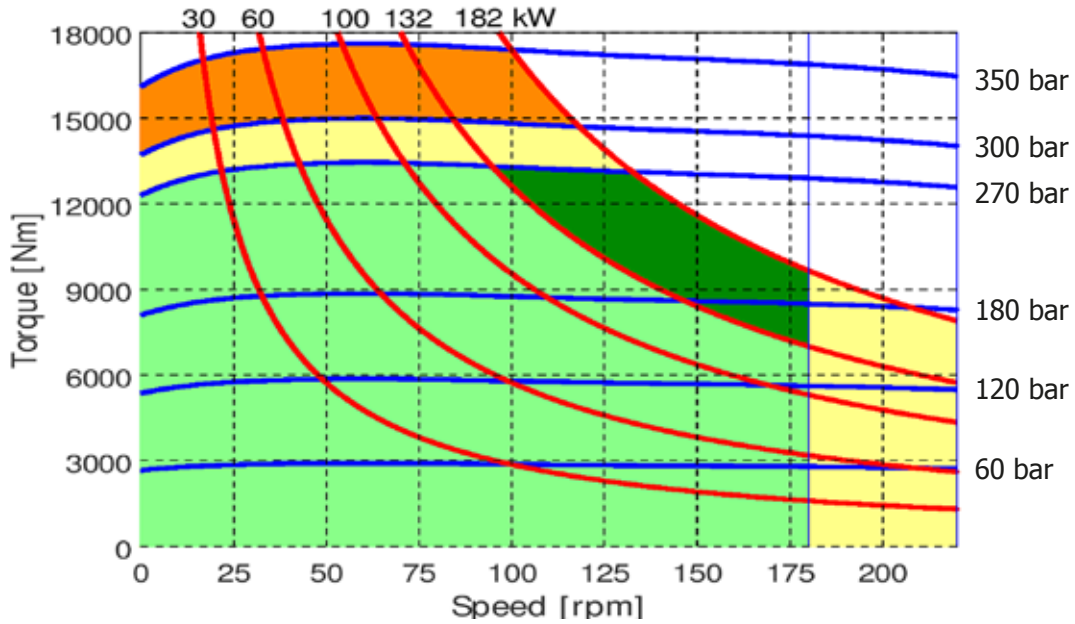

R8M 3600 H7

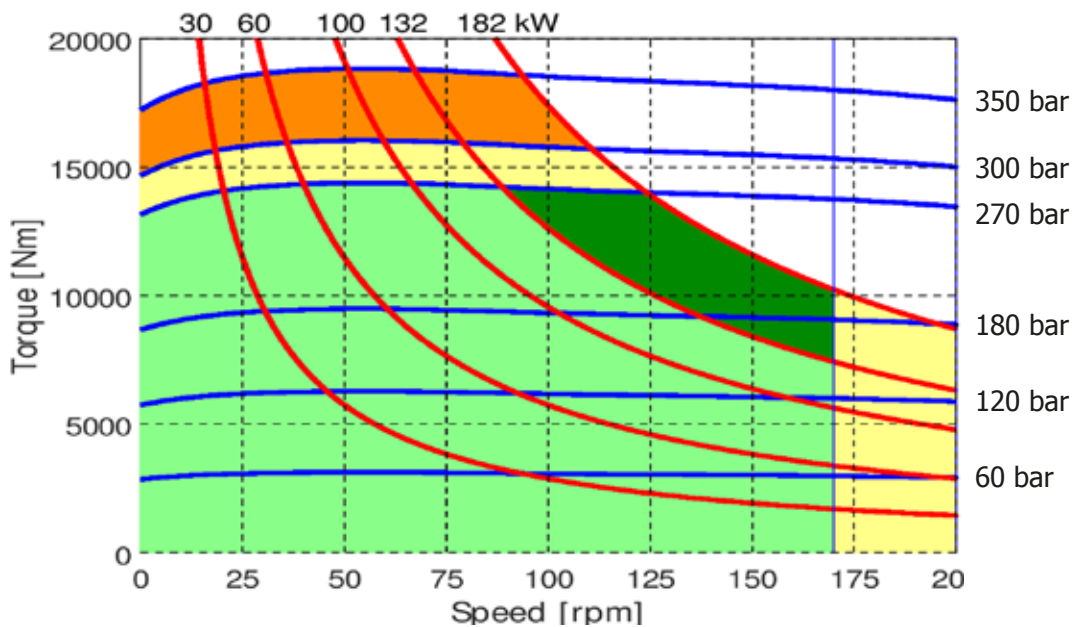

- Continuous operation
- Continuous operation with flushing or intermittent operation (see below for intermittent operation)
- Intermittent operation: permitted for a 15% of duty cycle, for 3 minutes maximum period
- Peak operation: permitted for very short periods (3-5 seconds every 10-15 minutes)

The above diagrams are referring to the hydraulic motor working with a fluid in ideal conditions (viscosity at 40 cSt). In case the working temperature increases and viscosity reach values under the recommended values (see hydraulic fluid recommendations) flushing must be performed or ISO oil grade must be changed. The working temperature must not overcome 70 °C.

R8M 3900 H7

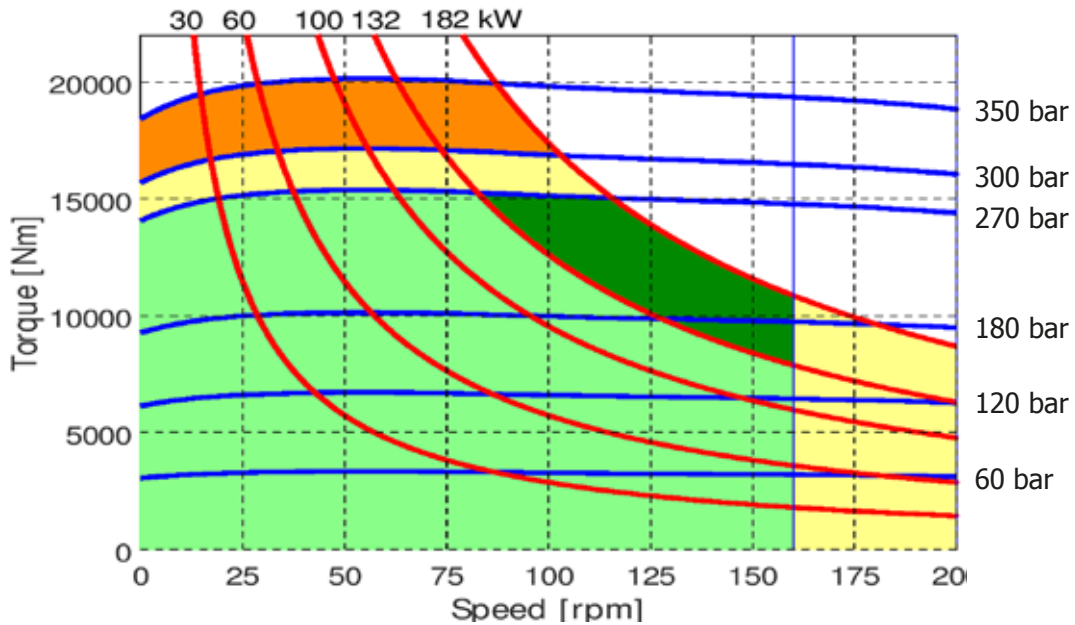

R8M 4300 H7

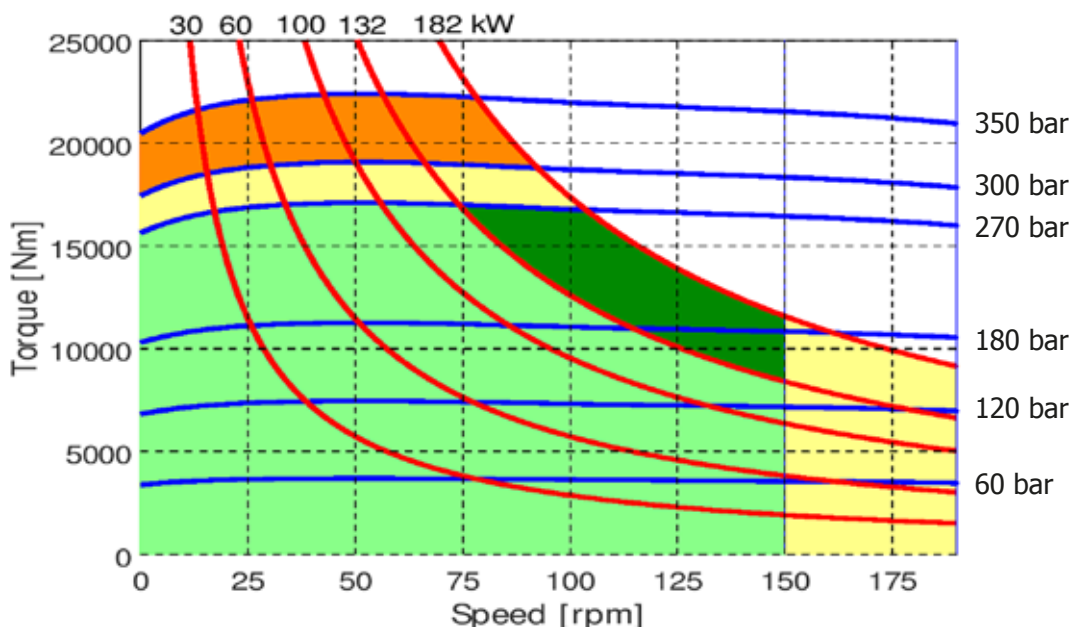

- Continuous operation
- Continuous operation with flushing or intermittent operation (see below for intermittent operation)
- Intermittent operation: permitted for a 15% of duty cycle, for 3 minutes maximum period
- Peak operation: permitted for very short periods (3-5 seconds every 10-15 minutes)

The above diagrams are referring to the hydraulic motor working with a fluid in ideal conditions (viscosity at 40 cSt). In case the working temperature increases and viscosity reach values under the recommended values (see hydraulic fluid recommendations) flushing must be performed or ISO oil grade must be changed. The working temperature must not overcome 70 °C.

R8M H7 - PERFORMANCE CURVES

R8M 4600 H7

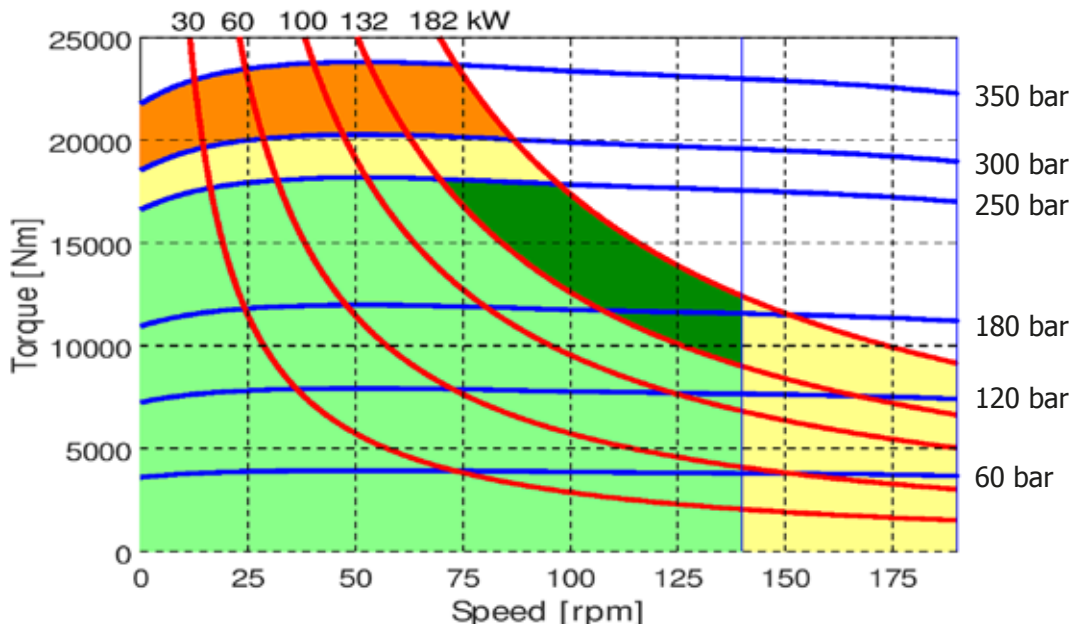

R8M 5000 H7

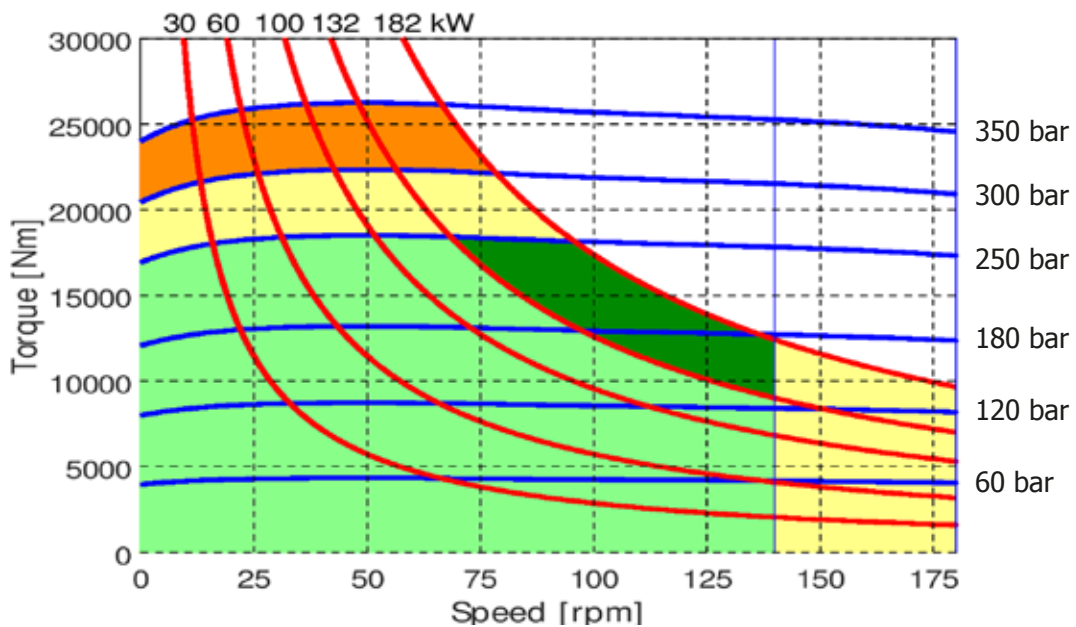

- Continuous operation
- Continuous operation with flushing or intermittent operation (see below for intermittent operation)
- Intermittent operation: permitted for a 15% of duty cycle, for 3 minutes maximum period
- Peak operation: permitted for very short periods (3-5 seconds every 10-15 minutes)

The above diagrams are referring to the hydraulic motor working with a fluid in ideal conditions (viscosity at 40 cSt). In case the working temperature increases and viscosity reach values under the recommended values (see hydraulic fluid recommendations) flushing must be performed or ISO oil grade must be changed. The working temperature must not overcome 70 °C.

R8M 5400 H7

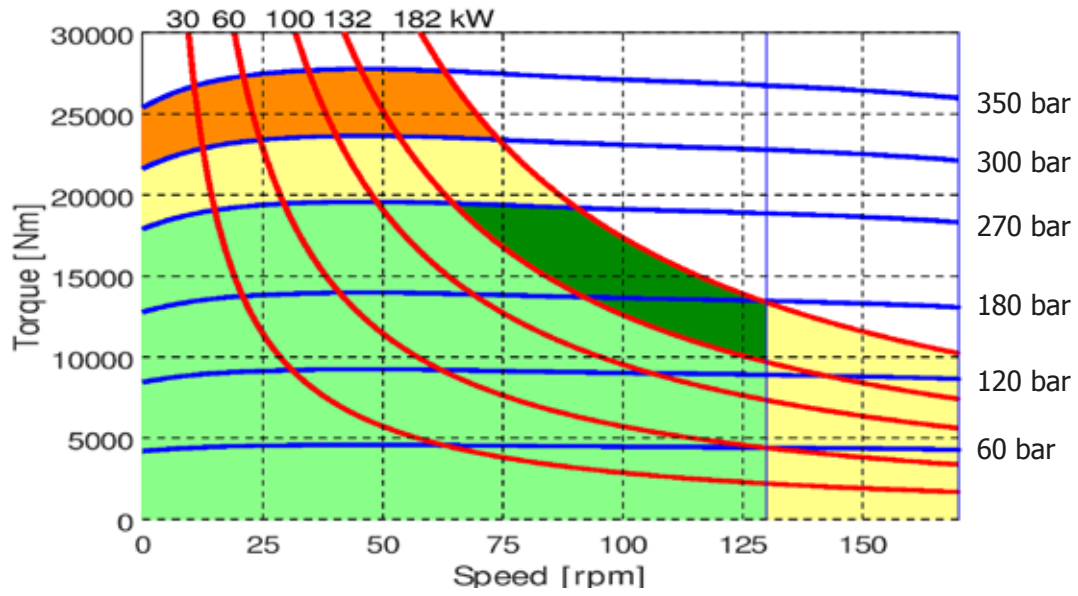

R8M H7 - PERFORMANCE CURVES

BEARING LIFE

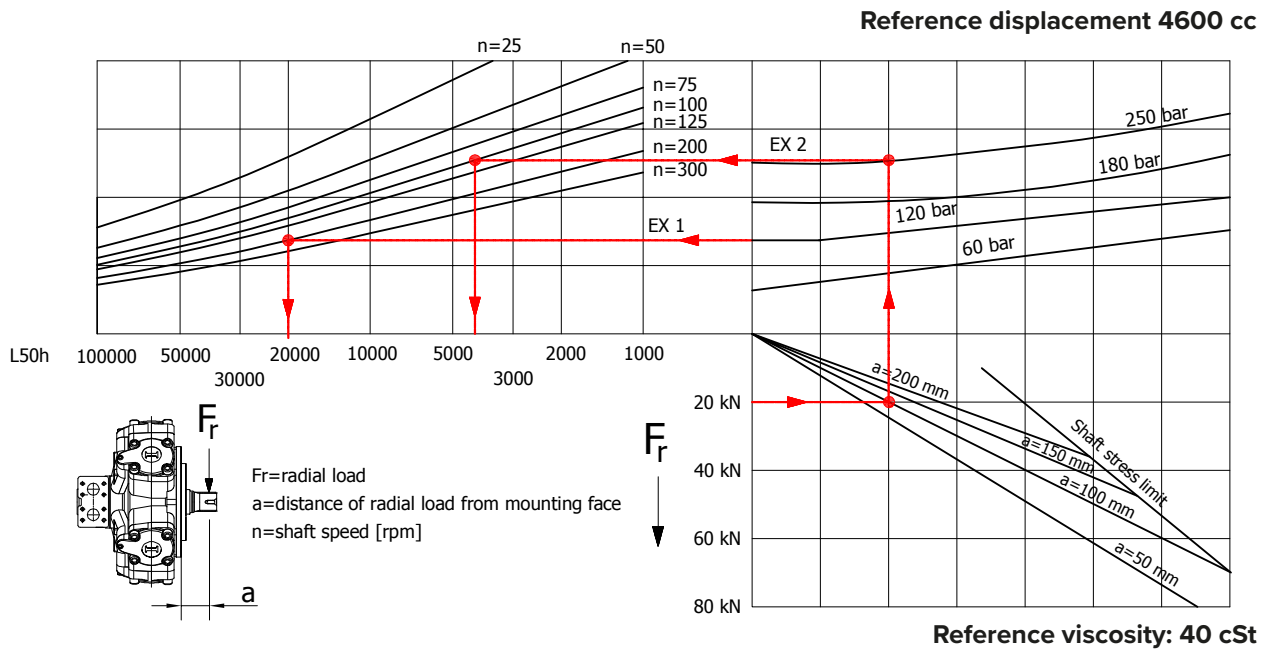

Example:

We suppose (EX1): $p=120$ [bar], $n=200$ [rpm]; we obtain an average lifetime of 20000 [h].

If we suppose (EX2): $F_r=20$ [kN], $a=100$ [mm], $n=100$ [rpm] and $p=250$ [bar] we obtain an average lifetime of 4000 [h].

The above data are referring to the R8M H7 series motors, displacement 4600 cc.

R8M H7 - ORDERING CODE

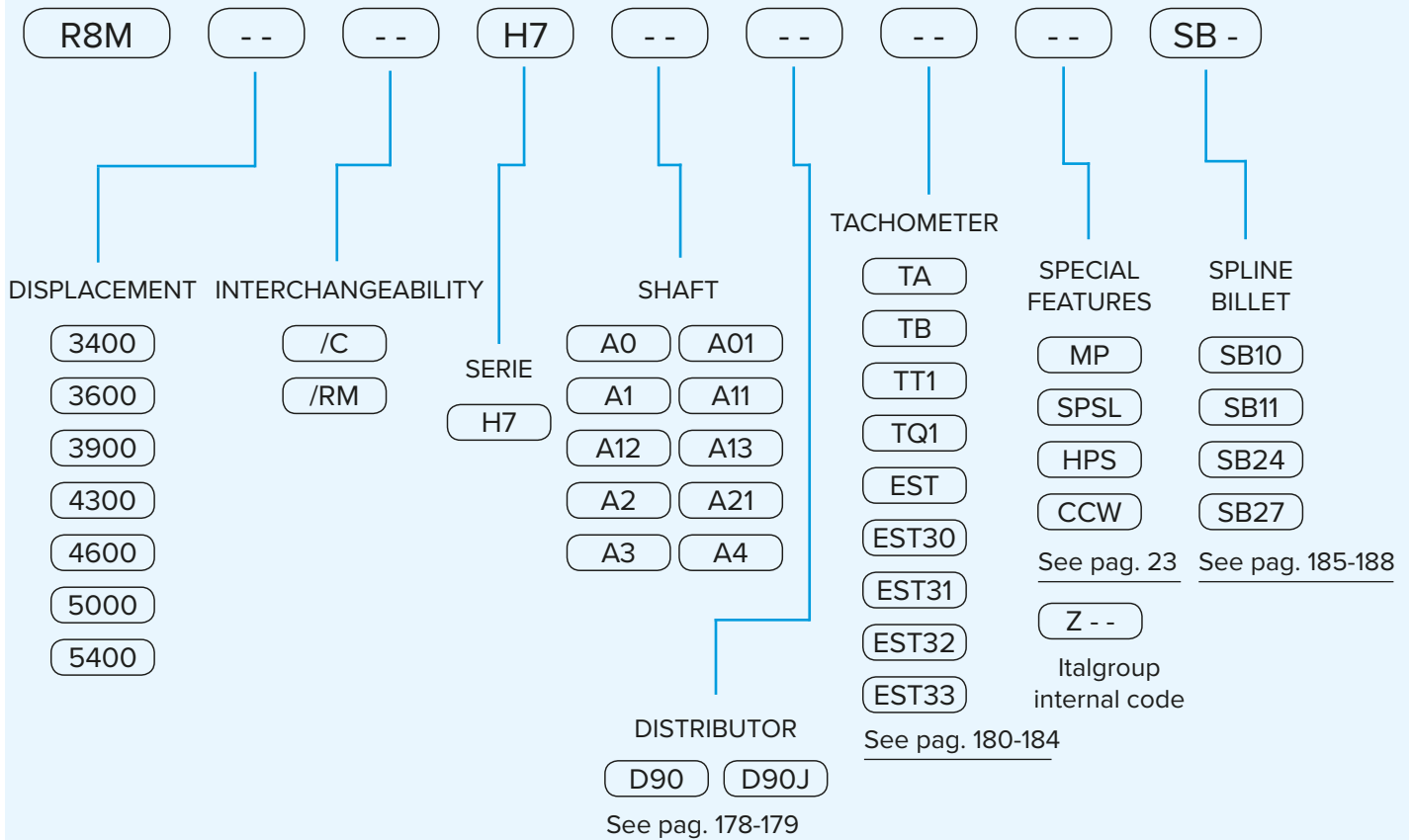

EXAMPLES:

R8M 4600 H7 A1 D90 CCW
 R8M 5000 H7 A0 D90 SB10
 R8M 5400/C H7 A0 D90

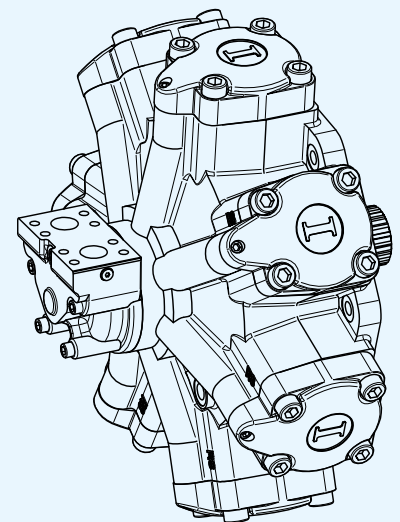

MOTOR DISTRIBUTORS

D40-D416-D31B-D310B-D36B-D316B

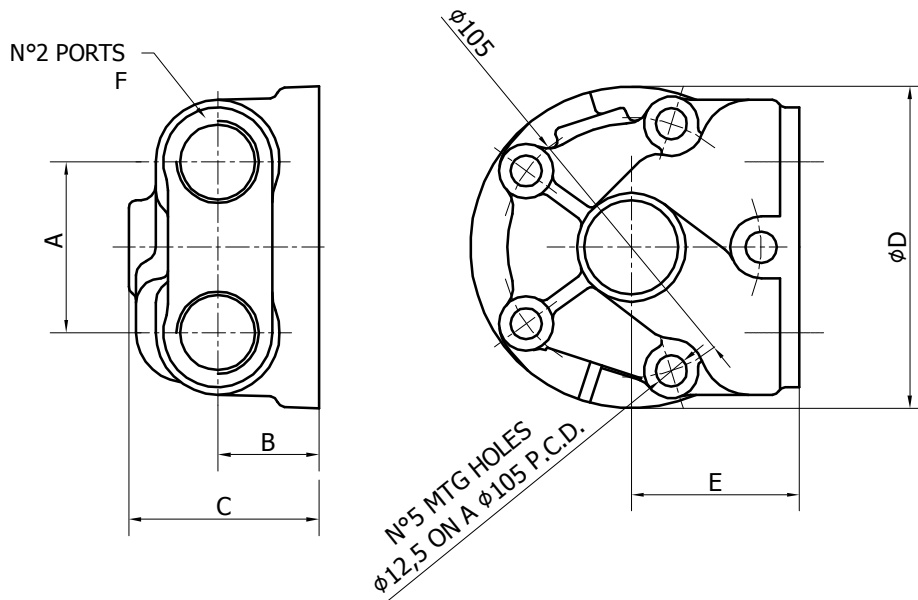

D47-D75-D90

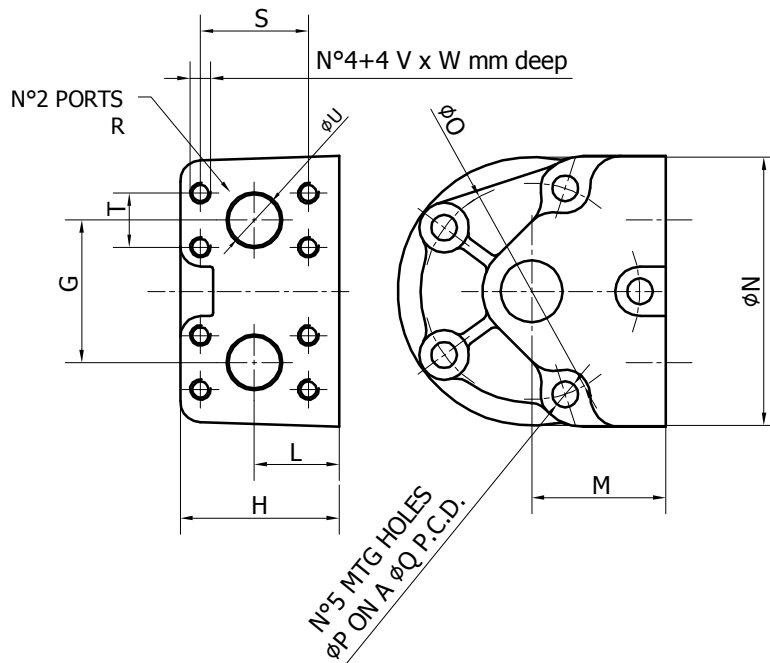

		D40	D416	D31B	D310B	D36B	D316B	D47	D75	D90
A	[mm]	69	69	56	56	56	56			
B	[mm]	41	41	39	39	39	39			
C	[mm]	77	77	67	67	67	67			
D	[mm]	130	130	125	125	125	125			
E	[mm]	68	68	65	65	65	65			
F	[]	1" BSP	1" SAE	3/4" BSP	1" BSP	3/4" SAE	1" SAE			
G	[mm]							69	83	100
H	[mm]							77	107	113
L	[mm]							41	55	59
M	[mm]							65	92	95
N	[mm]							130	170	190
O	[mm]							105	145	149
P	[mm]							12,5	14,5	14,5
Q										
R	[]							1" SAE 3000	1"1/2 SAE 3000	1"1/2 SAE 6000
S	[mm]							52,4	69,85	79,4
T	[mm]							26,2	35,7	36,7
U	[mm]							25	39	40
V	[mm]							M10	M12	M16
W	[mm]							19	22	22

		D31B	D310B	D36B	D40	D416	D47	D75	D90
MAX. CONT. FLOW	[l/min]	200	300	200	300	300	300	600	700
MAX. FLOW	[l/min]	400	400	400	400	400	400	1000	1200
MAX. CONT. PRESSURE	[bar]	300	300	300	300	300	300	300	300
PEAK PRESSURE	[bar]	500	500	500	500	500	500	500	500

IAM H1	●	●	●	●	●	●			
IAM H2	●	●	●	●	●	●			
IAM H3	●	●	●	●	●	●			
IAM H4	●	●	●	●	●	●			
IAM H45	●	●	●	●	●	●	●	●	●
IAM H5	●	●	●	●	●	●	●	●	●
IAM H55	●	●	●	●	●	●	●	●	●
IAM H6	●	●	●	●	●	●	●	●	●
IAM H7									●



● Standard version

◐ Special version: available on request. Please contact Italgroupp for more details

TACHOMETERS

J

Tacho drive plug 1/2" BSP

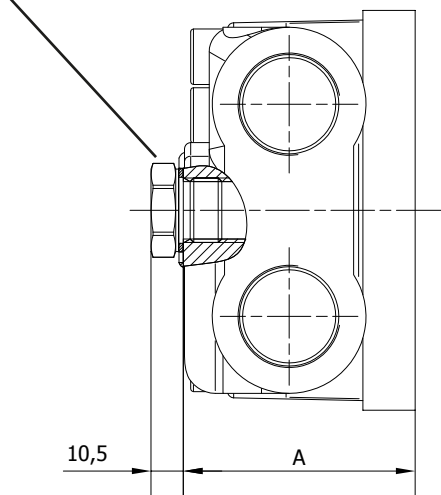

DISTRIBUTOR TYPE	A
D40/D416/D47	75,5
D31B/D310B/D36B/D316B	63,5
D75	101
D90	107

Tachometer predisposition **ONLY**

TA

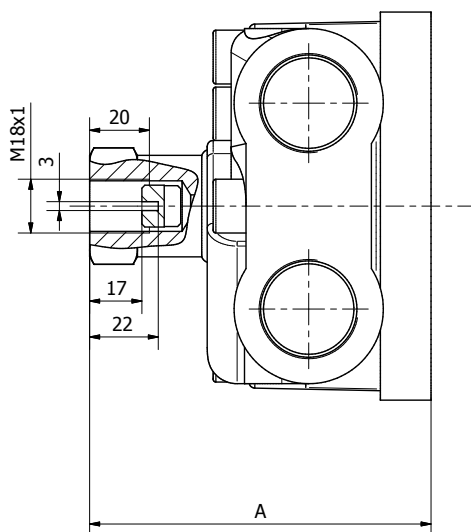

DISTRIBUTOR TYPE	A
D40/D416/D47	114,5
D31B/D310B/D36B/D316B	102,5
D75	140
D90	146

TB

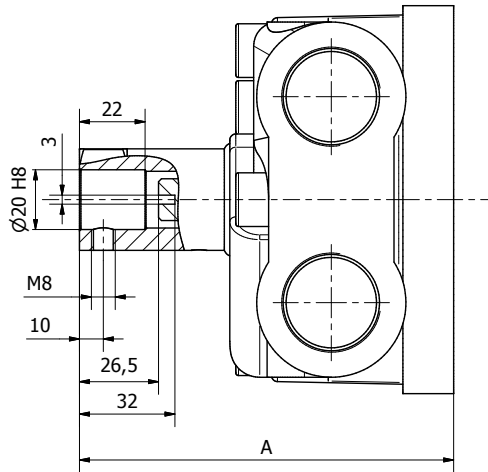

DISTRIBUTOR TYPE	A
D40/D416/D47	125,5
D31B/D310B/D36B/D316B	113,5
D75	151
D90	157

TT1

DETAIL X

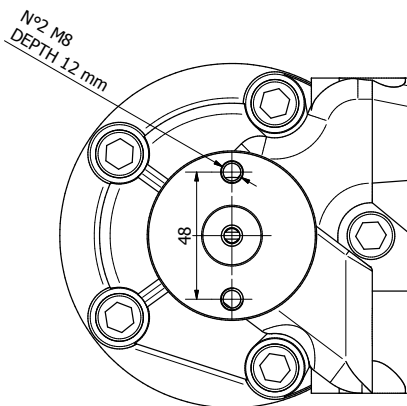
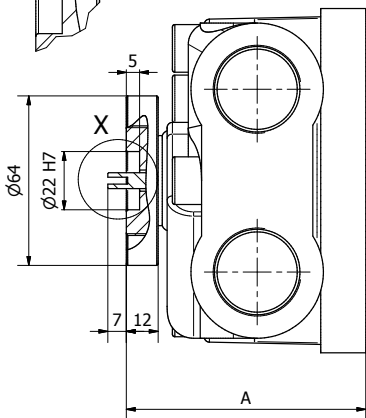
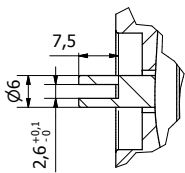

DISTRIBUTOR TYPE	A
D40/D416/D47	90,5
D31B/D310B/D36B/D316B	78,5
D75	116
D90	122

EST 30

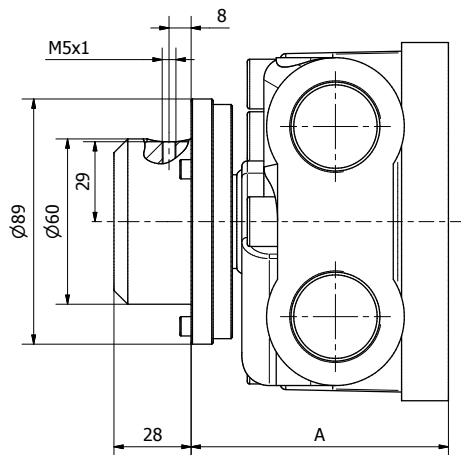

DISTRIBUTOR TYPE	A
D40/D416/D47	93,5
D31B/D310B/D36B/D316B	81,5
D75	119
D90	125

EST 30 ELECTRIC DATA	
POWER SUPPLY	10 - 30 VDC
IMPULSE / RPM	30
PROTECTION DEGREE	IP67
OUTPUT	NPN / PNP (*)

(*) Customer has to select it at the order stage. In case of non-indication by customer, NPN version will be supplied as standard.

EST 31

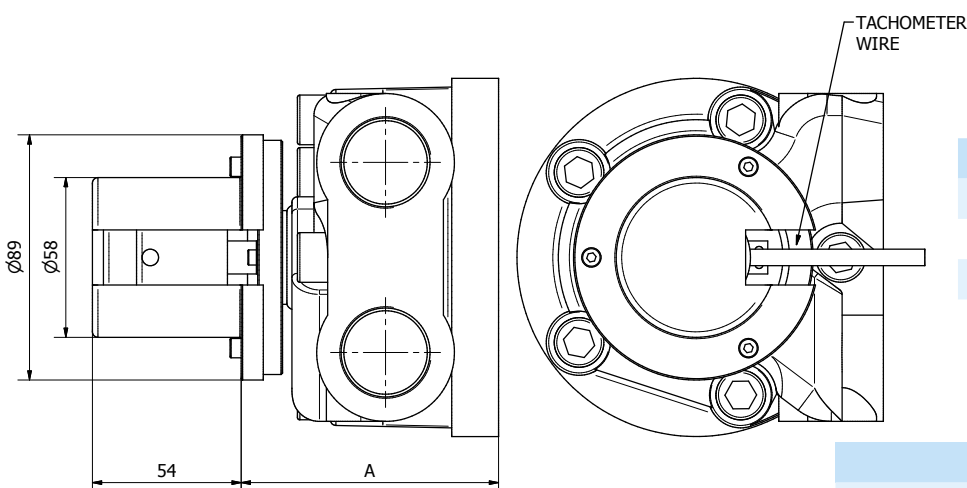

DISTRIBUTOR TYPE	A
D40/D416/D47	93,5
D31B/D310B/D36B/D316B	81,5
D75	119
D90	125

EST 31 ELECTRIC DATA	
POWER SUPPLY	8 - 24 VDC
IMPULSE / RPM	500
PROTECTION DEGREE	IP65
OUTPUT	PUSH-PULL

TACHOMETERS

EST 32

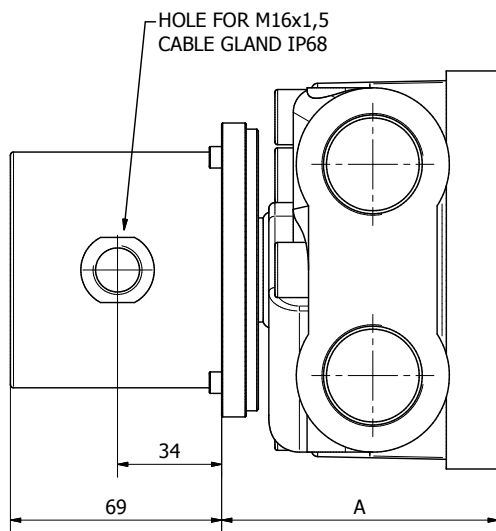

DISTRIBUTOR TYPE	A
D40/D416/D47	93,5
D31B/D310B/D36B/D316B	81,5
D75	119
D90	125

EST 32 ELECTRIC DATA	
POWER SUPPLY	8 - 24 VDC
IMPULSE / RPM	4096
PROTECTION DEGREE	IP67
OUTPUT	SSI interface

EST 33

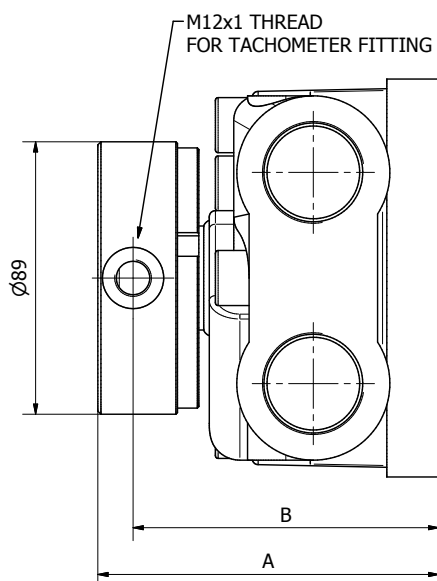

DISTRIBUTOR TYPE	A	B
D40/D416/D47	99,5	88
D31B/D310B/D36B/D316B	87,5	76
D75	125	113,5
D90	131	119,5

SENSOR NOT INCLUDED

SPLINE BILLETS

SB1

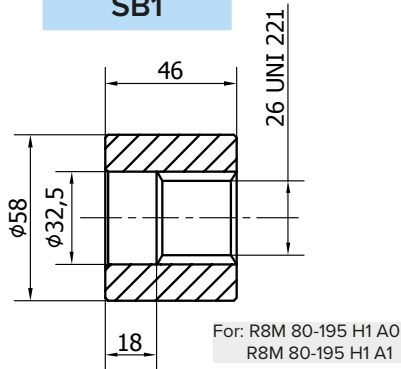

SB2

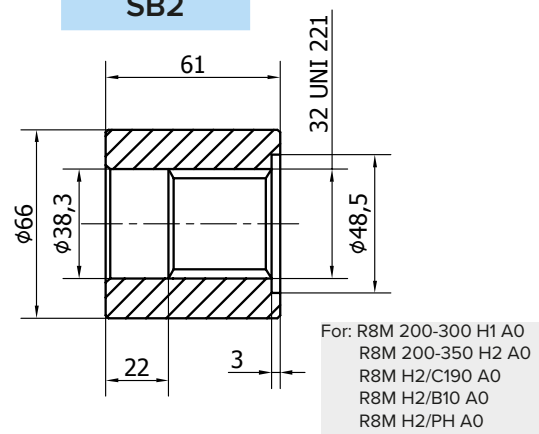

SB3

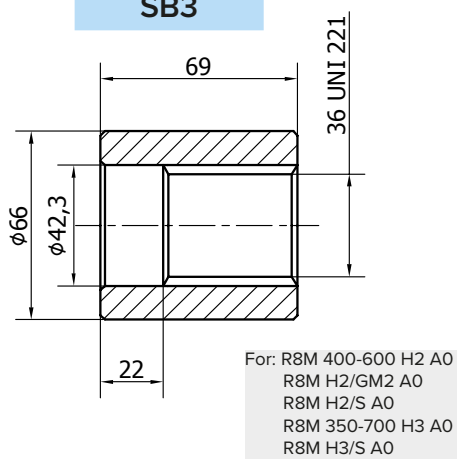

SB4

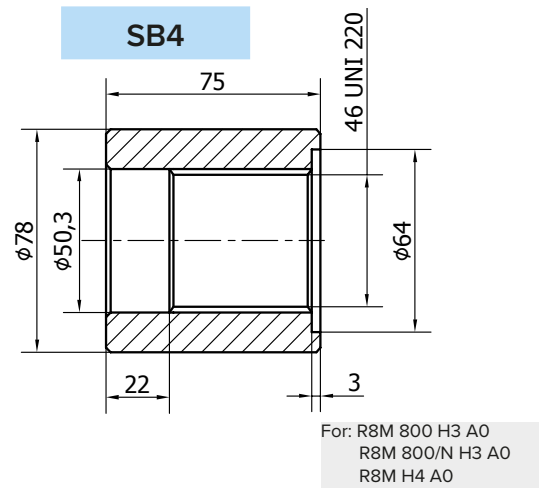

SB5

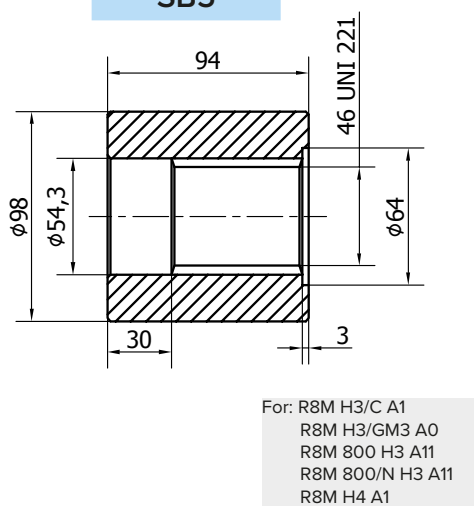

SB6

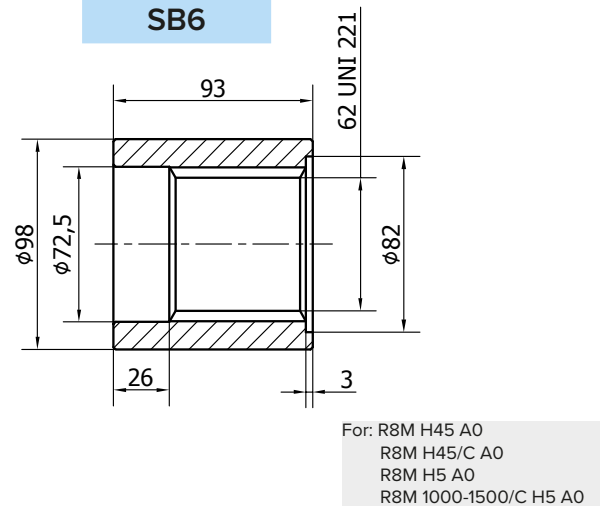

SPLINED BILLETS

SB7

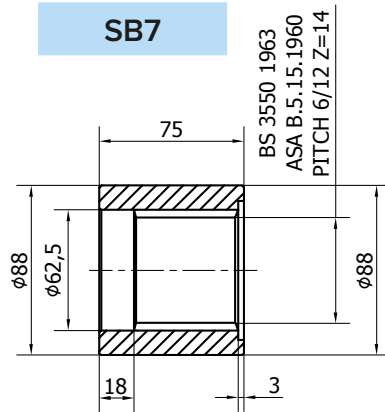

For: R8M H45 A1
R8M H5 A1

SB8

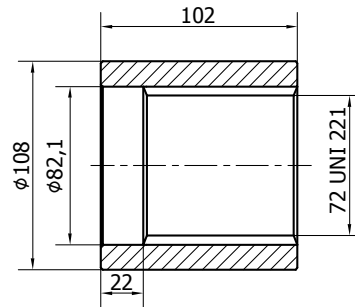

For: R8M 1600-2200/C A0

SB9

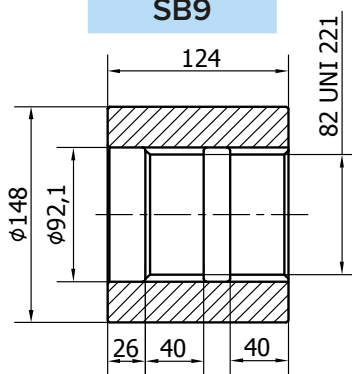

For: R8M H55 A0
R8M H55/C A0
R8M H6 A0
R8M H6/C A0

SB10

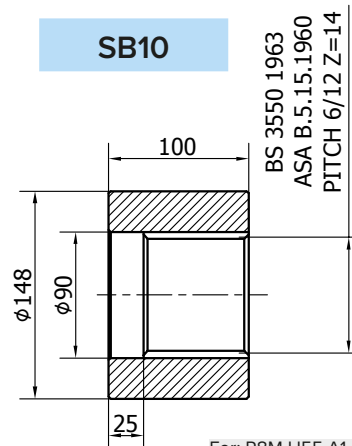

For: R8M H55 A1
R8M H6 A1
R8M H7 A1

SB11

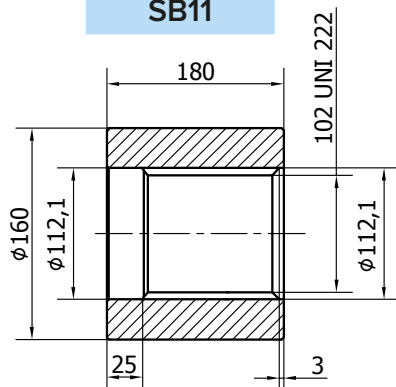

For: R8M H7 A0
R8M H7/C A0

SB14

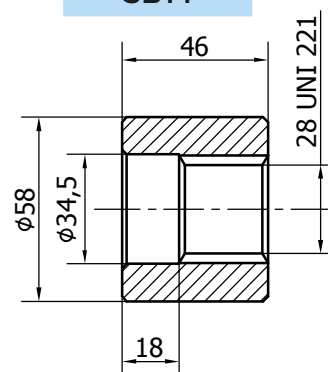

For: R8M H1/GM05 A0
R8M H1/GM1 A0
R8M H1/BH A0
R8M H1 A11

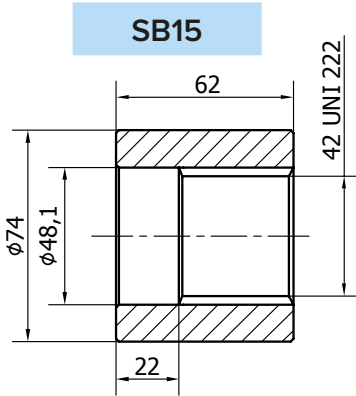

For: R8M H2/C300 A0

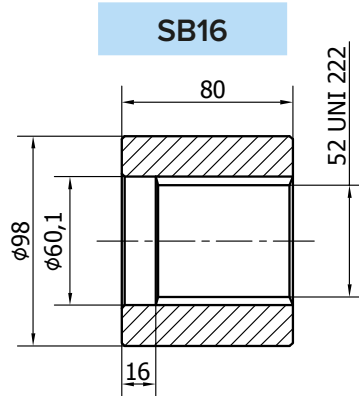

For: R8M H4/C A0

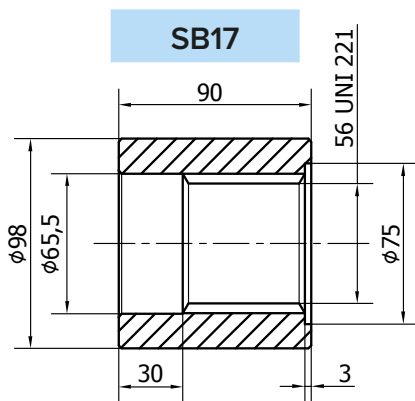

For: R8M H4/S A0
R8M H4/GM4 A0
R8M H5/GM5 A0

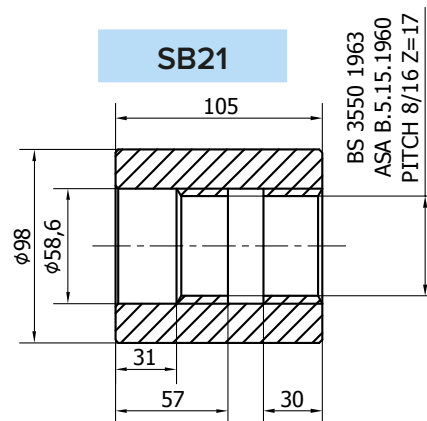

For: R8M H3/B30 A0
R8M H4/B45 A1

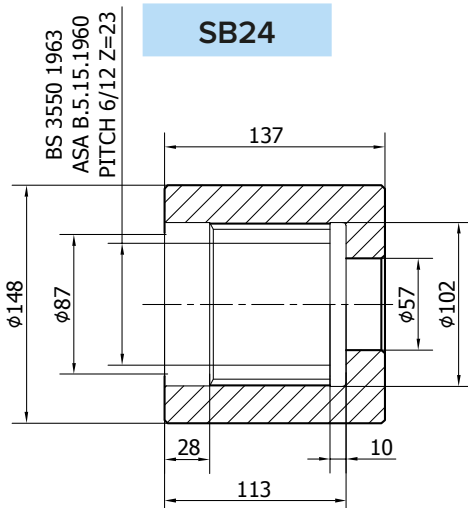

For: R8M H6 A11
R8M H7 A13

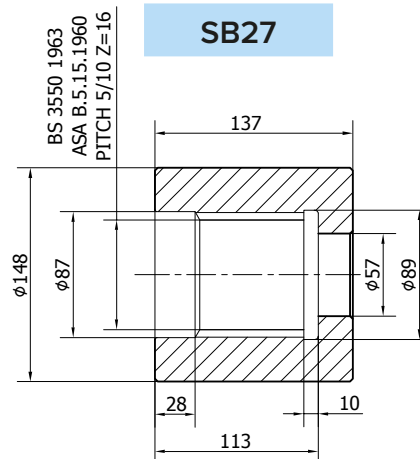

For: R8M H6 A12
R8M H7 A12

SPLINED BILLETS

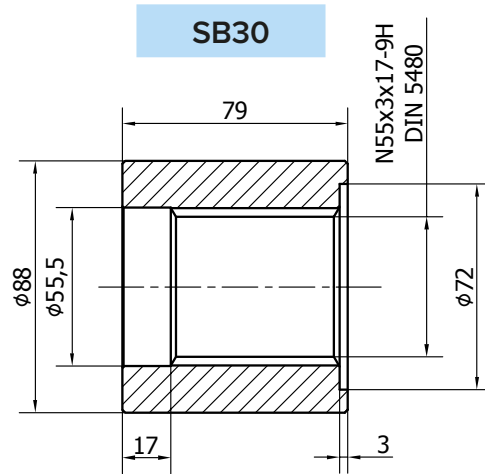

For: R8M H3/B30 A1
R8M H3/C A11
R8M H4/B45 A4

SPLINED BARS

B8076

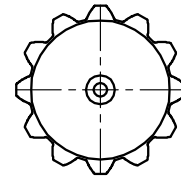
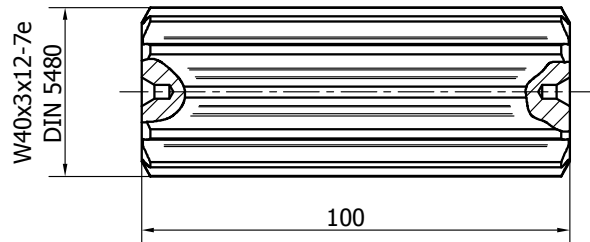

For: R8M H3 A31
R8M H3/GM3 A31
R8M H3/S A31

B8078

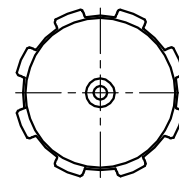
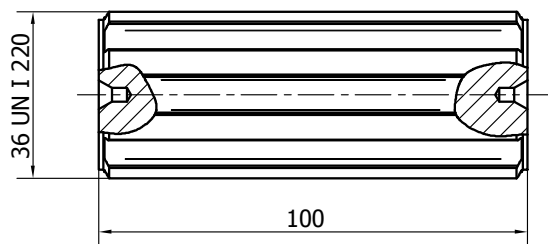

For: R8M 200-350 H2 A3
R8M 400-600 H2 A3
R8M H2/GM2 A3
R8M H2/S A3
R8M H3 A3
R8M H3/GM3 A3
R8M H3/S A3

B8079

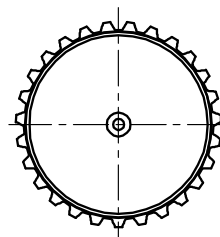
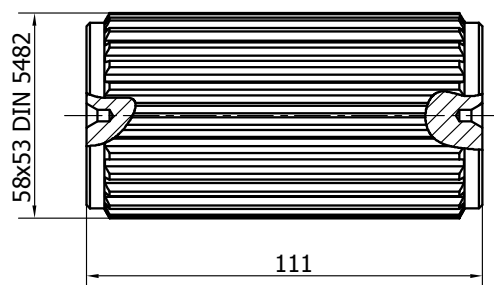

For: R8M H4 A3

ADAPTOR FLANGES

FL1

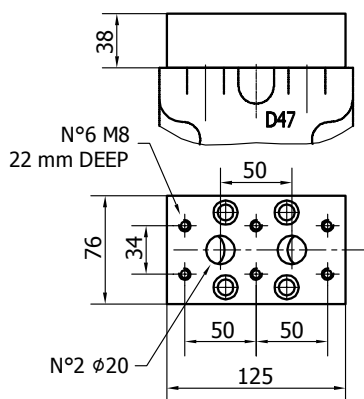

Connection block, fitting D47 distributor, for motor MR125/160/190/200/250/300/330

FL2

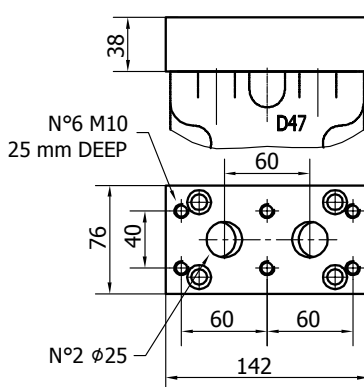

Connection block, fitting D47 distributor, for motor MR350/450/500/600/700/800

FL4

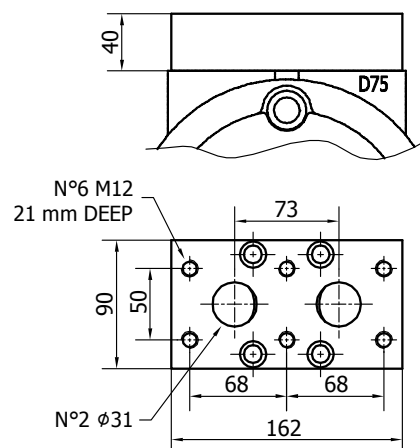

Connection block, fitting D75 distributor, for motor MR1100/1400/1600/1800/2100

FL5

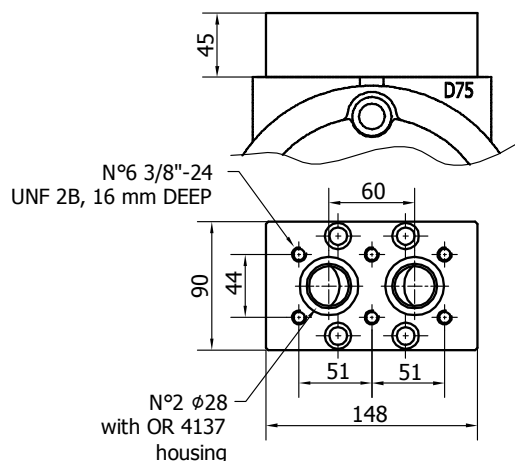

Connection block, fitting D75 distributor, for motor HMB 60/80/100 - S03

FL6

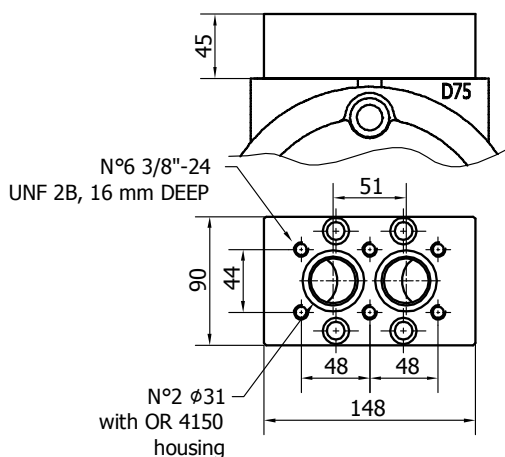

Connection block, fitting D75 distributor, for motor HMB 60/80/100 - S04

FL7

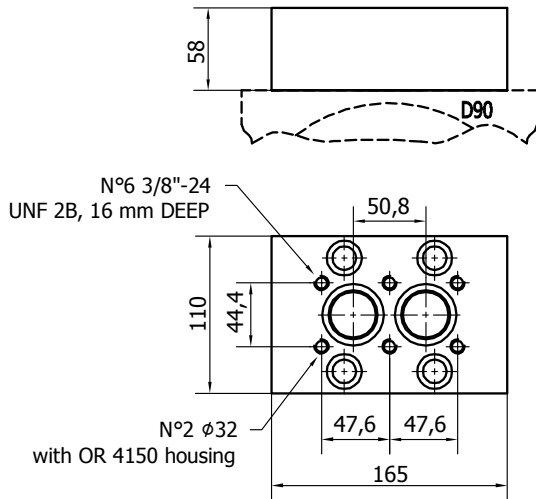

Connection block, fitting D90 distributor, for motor HMB 125/150/200 - S04

FL8

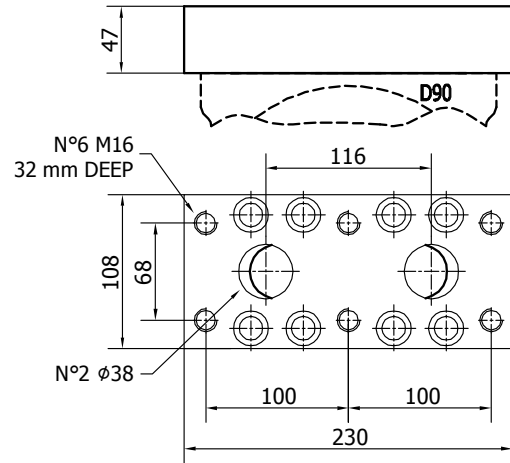

Connection block, fitting D90 distributor, for motor MR 3600/4500, MRE 5400

FL10

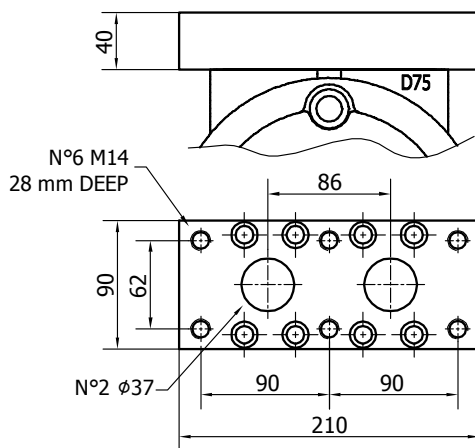

Connection block, fitting D75 distributor, for motor MR 2400/2800, MRE 3100

FL16

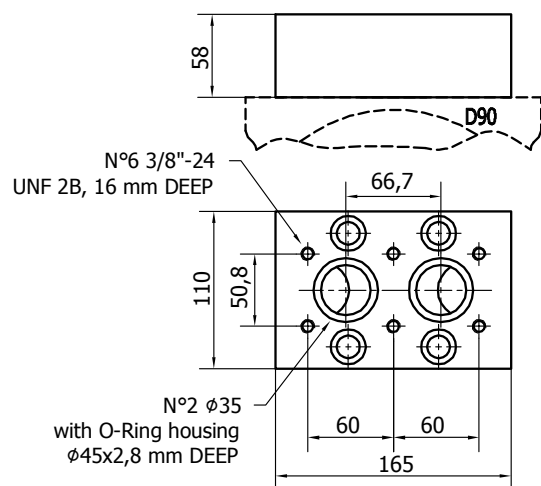

Connection block, fitting D90 distributor, for motor HMB 270/325 - S04

R8M - VALVES

SINGLE OVERCENTER - OVSA 160	Pag. 194
DOUBLE OVERCENTER - OVDA 160	Pag. 195
FLUSHING - AP 40	Pag. 196
DOUBLE RELIEF - RVDA 80	Pag. 197
ANTICAVITATION - AC 80	Pag. 198
DOUBLE RELIEF AND ANTICAVITATION - RVDAC 80	Pag. 199
DOUBLE RELIEF AND FLUSHING - RVDAP 80	Pag. 200
SINGLE RELIEF AND ANTICAVITATION - RVSAC 200	Pag. 201
DOUBLE OVERCENTER - OVDA 300	Pag. 202
DOUBLE RELIEF - RVDA 200	Pag. 203
SINGLE RELIEF AND OVERCENTER - ORVSA 200	Pag. 204
DOUBLE RELIEF AND SINGLE OVERCENTER - DRVSO200EP	Pag. 205
DOUBLE OVERCENTER - OVDA 480	Pag. 206
DOUBLE RELIEF - RVDA 380	Pag. 207
SINGLE RELIEF AND OVERCENTER - ORVSA 480	Pag. 208
DOUBLE RELIEF AND FLUSHING - RVDAP 90	Pag. 209
VALVES ORDERING CODE	Pag. 210

SINGLE OVERCENTER - OVSA 160

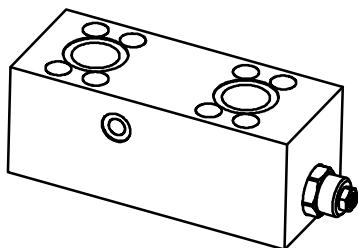

PORTS DIMENSION

V1, V2	1" BSP
F	1/4" BSP
C1, C2	O-Ring 4137 Parker code 2-220

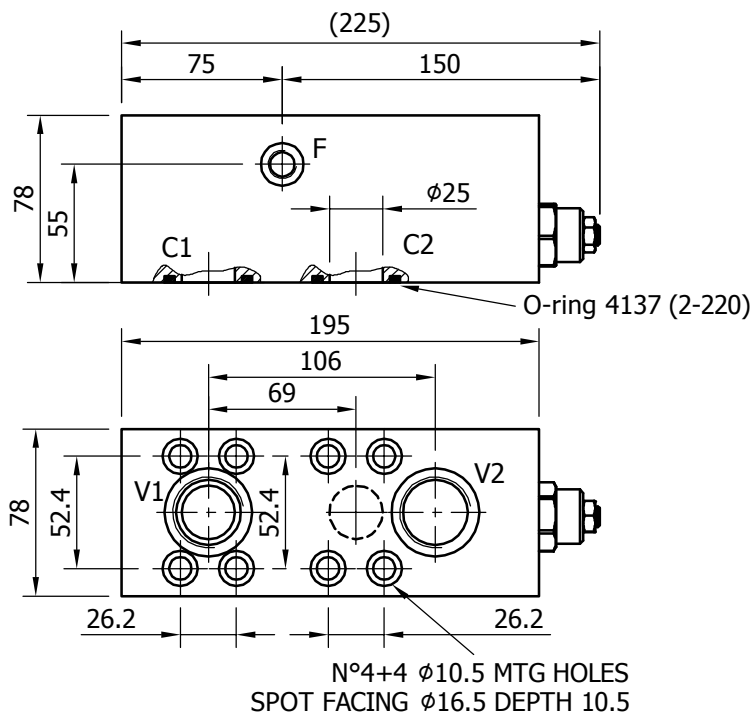

TECHNICAL DATA

		OVSA.160.1.D47	OVSA.160.2.D47	OVSA.160.3.D47
NOMINAL FLOW	[l/min]	120	120	120
MAXIMUM FLOW	[l/min]	160	160	160
MAXIMUM PRESSURE	[bar]	350	350	350
PILOT RATIO	□	1 (3:1)	2 (4.5:1)	3 (10:1)
RELIEF VALVE SETTING RANGE	[bar]	70-280	140-350	140-350
STANDARD RELIEF SETTING	[bar]	210	210	210
BLOCK MATERIAL	□	steel	steel	steel
DISTRIBUTOR FITTING	□	D47	D47	D47

Cartridge characteristic

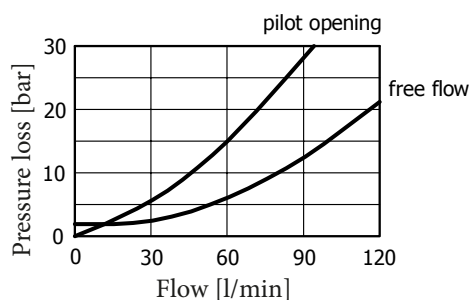

Hydraulic circuit

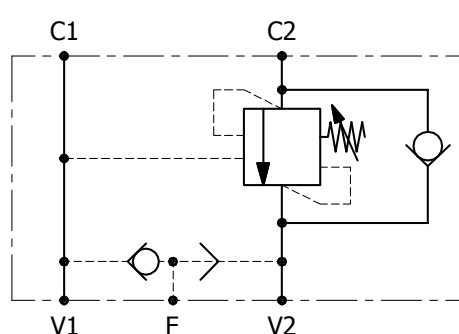

DOUBLE OVERCENTER - OVDA 160

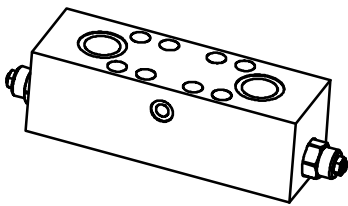

PORTS DIMENSION	
V1, V2	1" BSP
F	1/4" BSP
C1, C2	O-Ring 4137 Parker code 2-220

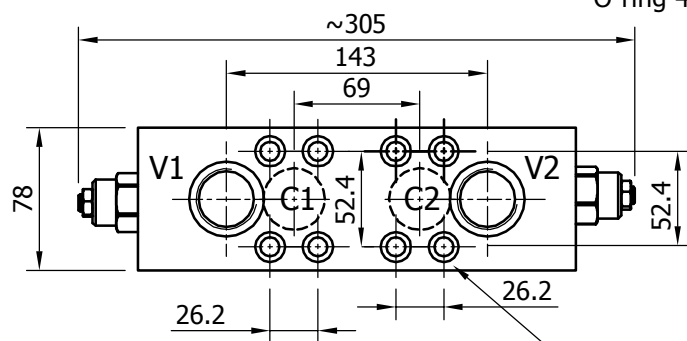
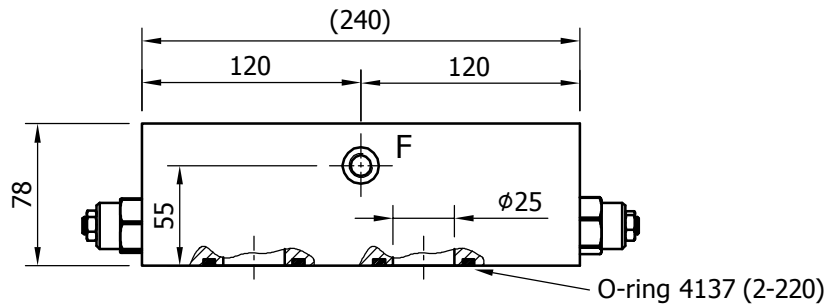

N°4+4 ϕ 10.5 MTG HOLES
SPOT FACING ϕ 16.5 DEPTH 10.5

TECHNICAL DATA

		OVDA.160.1.D47	OVDA.160.2.D47	OVDA.160.3.D47
NOMINAL FLOW	[l/min]	120	120	120
MAXIMUM FLOW	[l/min]	160	160	160
MAXIMUM PRESSURE	[bar]	350	350	350
PILOT RATIO	[]	1 (3:1)	2 (4.5:1)	3 (10:1)
RELIEF VALVE SETTING RANGE	[bar]	70-280	40-350	140-350
STANDARD RELIEF SETTING	[bar]	210	210	210
BLOCK MATERIAL	[]	steel	steel	steel
DISTRIBUTOR FITTING	[]	D47	D47	D47

Cartridge characteristic

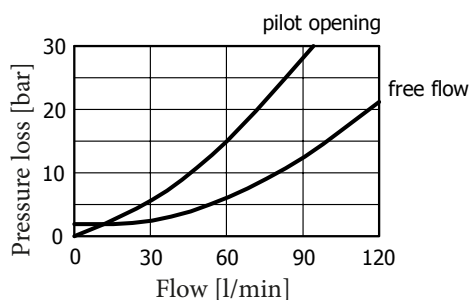

Hydraulic circuit

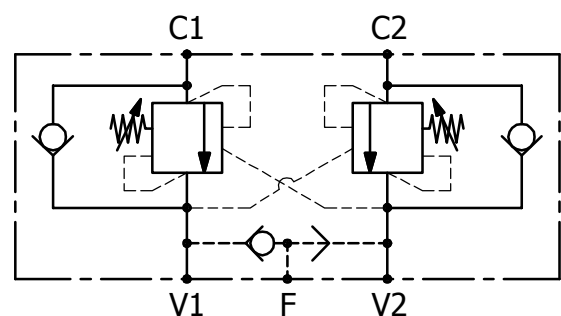

FLUSHING - AP 40

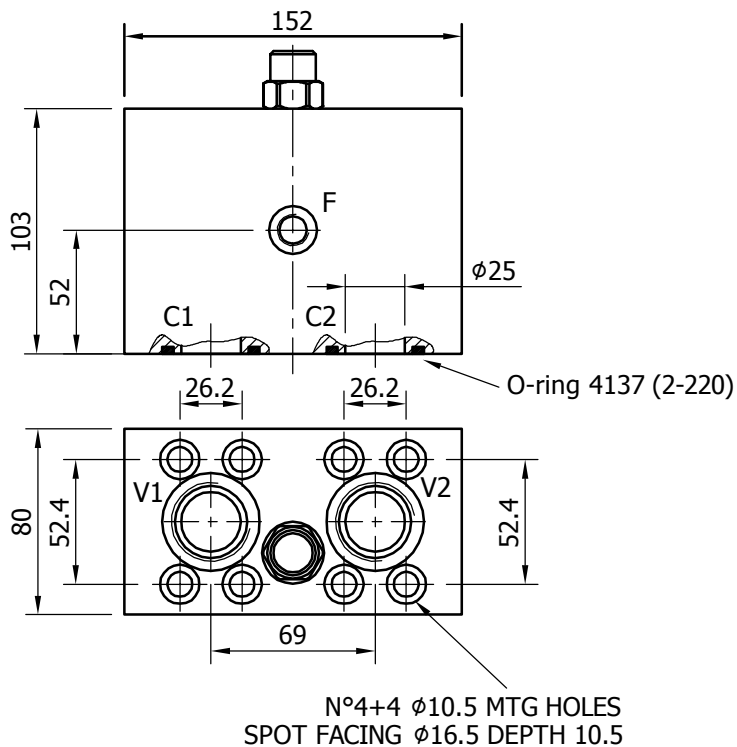
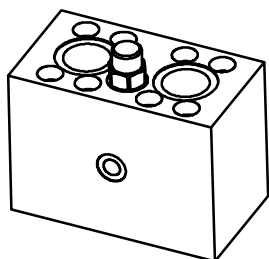

PORTS DIMENSION

V1, V2	1" BSP
F	1/4" BSP
C1, C2	O-Ring 4137 Parker code 2-220

TECHNICAL DATA

		AP40.D47
MAXIMUM FLUSHING FLOW	[l/min]	80
MAXIMUM PRESSURE	[bar]	350
BLOCK MATERIAL	□	steel
DISTRIBUTOR FITTING	□	D47

Cartridge characteristic

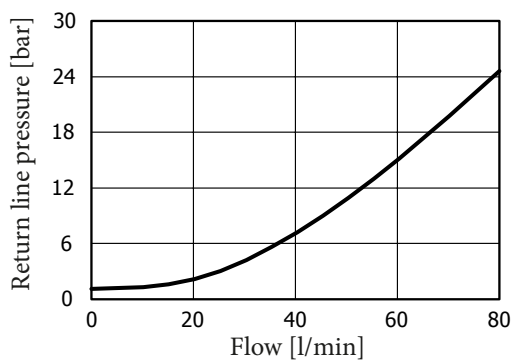

Hydraulic circuit

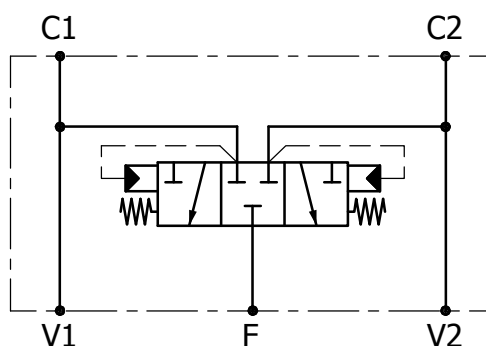

DOUBLE RELIEF - RVDA 80

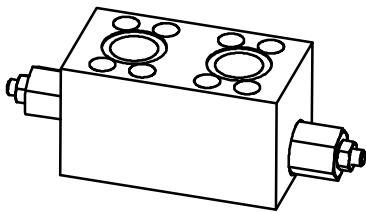

PORTS DIMENSION

V1, V2	1" BSP
C1, C2	O-Ring 4137 Parker code 2-220

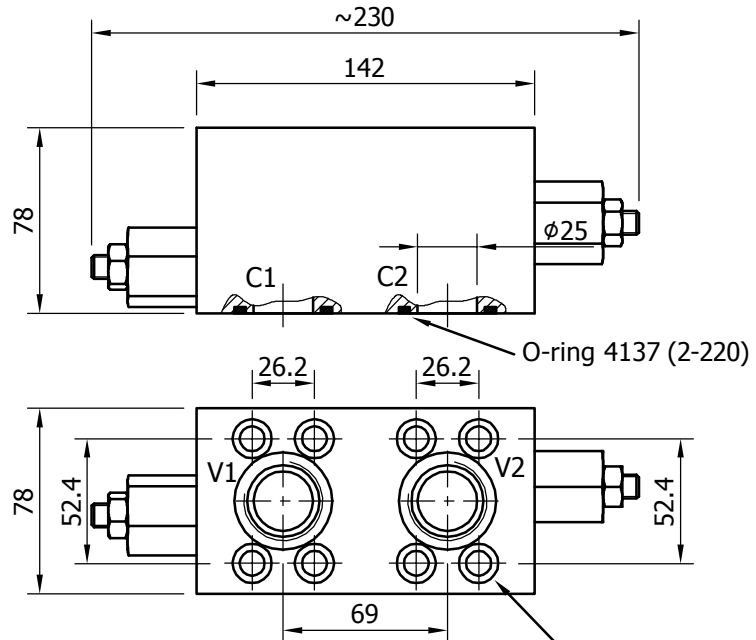

N°4+4 $\phi 10.5$ MTG HOLES
SPOT FACING $\phi 16.5$ DEPTH 10.5

TECHNICAL DATA

RVDA.80.C.D47

NOMINAL FLOW	[l/min]	150
MAXIMUM FLOW	[l/min]	200
MAXIMUM PRESSURE	[bar]	350
RELIEF VALVE SETTING RANGE	[bar]	C (20-350)
STANDARD RELIEF SETTING	[bar]	20
BLOCK MATERIAL	[]	steel
DISTRIBUTOR FITTING	[]	D47

Hydraulic circuit

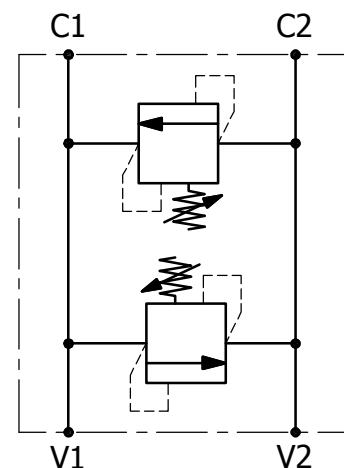

Cartridge typical pressure rise

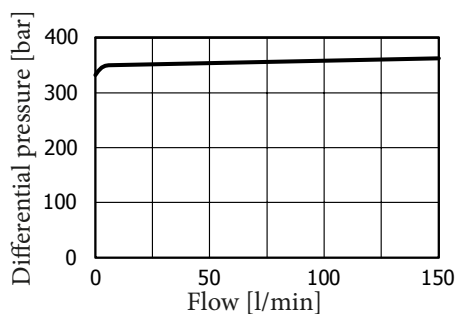

ANTICAVITATION - AC 80

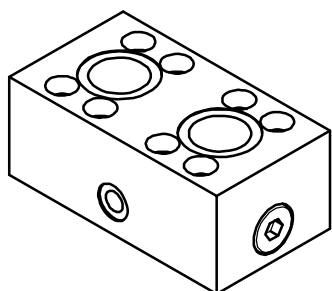

PORTS DIMENSION	
V1, V2	1" BSP
AC	1/4" BSP
C1, C2	O-Ring 4137 Parker code 2-220

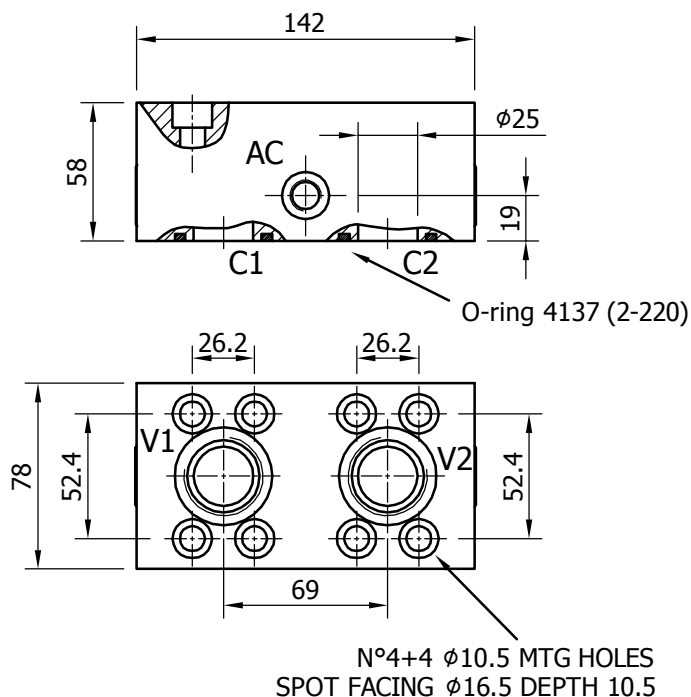

TECHNICAL DATA

		AC80.D47
NOMINAL FLOW	[l/min]	150
MAXIMUM FLOW	[l/min]	200
MAXIMUM PRESSURE	[bar]	350
MAXIMUM ANTICAVITATION FLOW (FROM AC TO C1 OR C2)	[l/min]	50
BLOCK MATERIAL	□	steel
DISTRIBUTOR FITTING	□	D47

Check valve flow/pressure curve

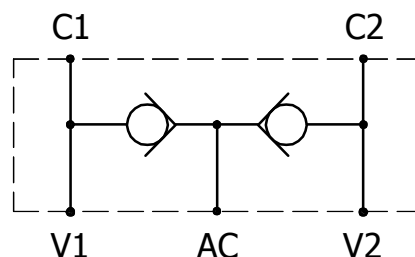
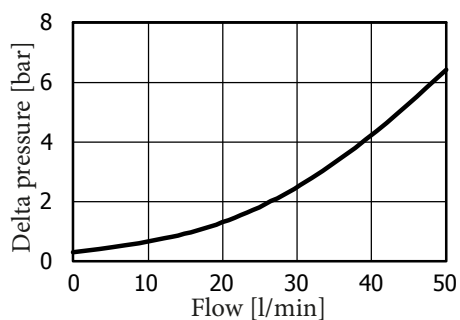

RELIEF & ANTICAVITATION - RVDAC80

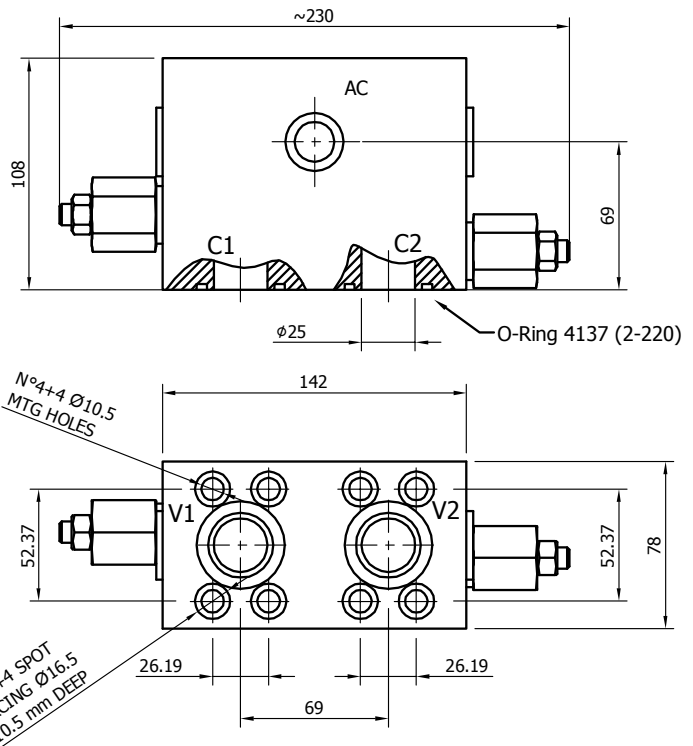
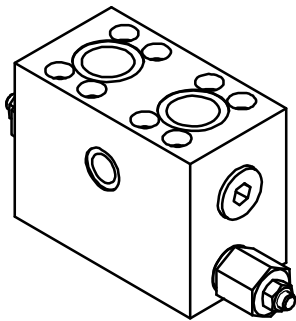

PORTS DIMENSION	
V1, V2	1" BSP
AC	1/4" BSP
C1, C2	O-Ring 4137 Parker code 2-220

TECHNICAL DATA

RVDAC80.C.D47		
NOMINAL FLOW	[l/min]	150
MAXIMUM FLOW	[l/min]	200
MAXIMUM PRESSURE	[bar]	350
RELIEF VALVE SETTING RANGE	[bar]	C (20-350)
STANDARD RELIEF SETTING	[bar]	20
MAXIMUM ANTICAVITATION FLOW (FROM AC TO C1 OR C2)	[l/min]	50
BLOCK MATERIAL	□	steel
DISTRIBUTOR FITTING	□	D47

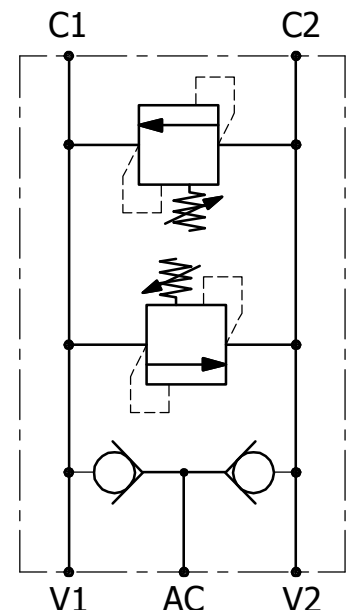

Relief cartridge typical pressure rise

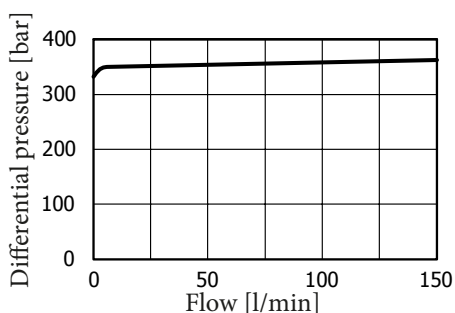

Check valve flow/pressure curve

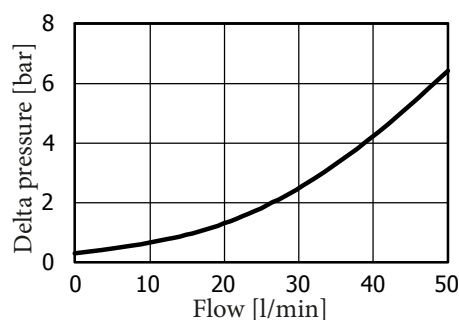

RELIEF & FLUSHING - RVDAP80

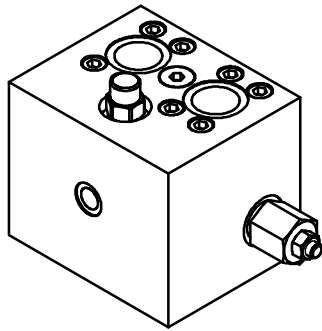

PORTS DIMENSION

V1, V2	1" BSP
F	1/4" BSP
C1, C2	O-Ring 4137 Parker code 2-220

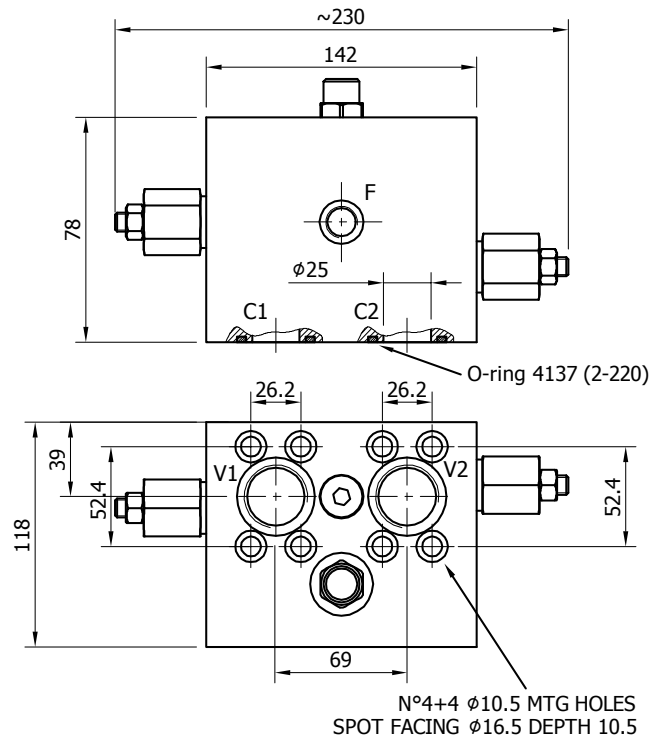

TECHNICAL DATA

		RVDAP80.C.D47
RELIEF VALVE MAXIMUM FLOW	[l/min]	200
RELIEF VALVE SETTING RANGE	[bar]	C (20-350)
STANDARD RELIEF SETTING	[bar]	70
MAXIMUM FLUSHING FLOW	[l/min]	80
MAXIMUM PRESSURE	[bar]	350
BLOCK MATERIAL	□	steel
DISTRIBUTOR FITTING	□	D47

Hydraulic circuit

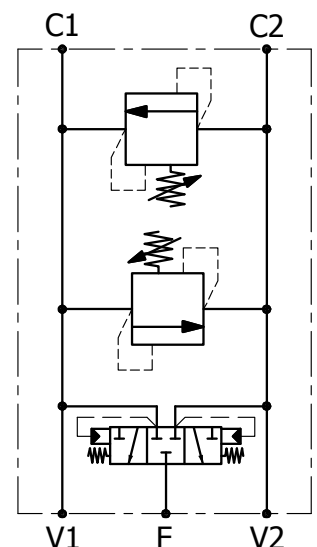

Relief cartridge typical pressure rise

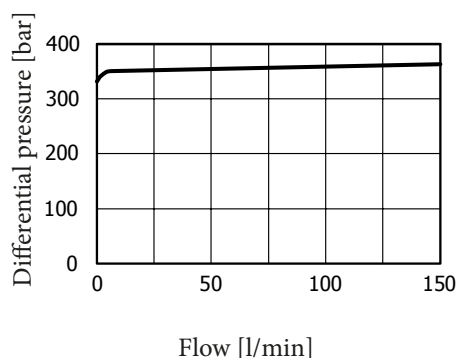

Flushing valve characteristic

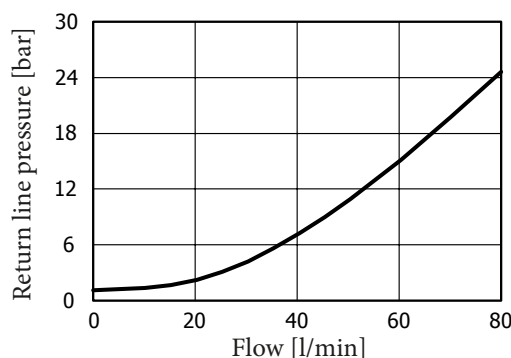

RELIEF & ANTICAVITATION - RVSAC200

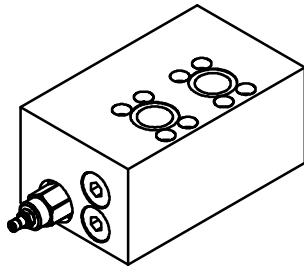

PORTS DIMENSION	
V1, V2	1" BSP
M1, M2	1/4" BSP
C1, C2	O-Ring 4137 Parker code 2-220

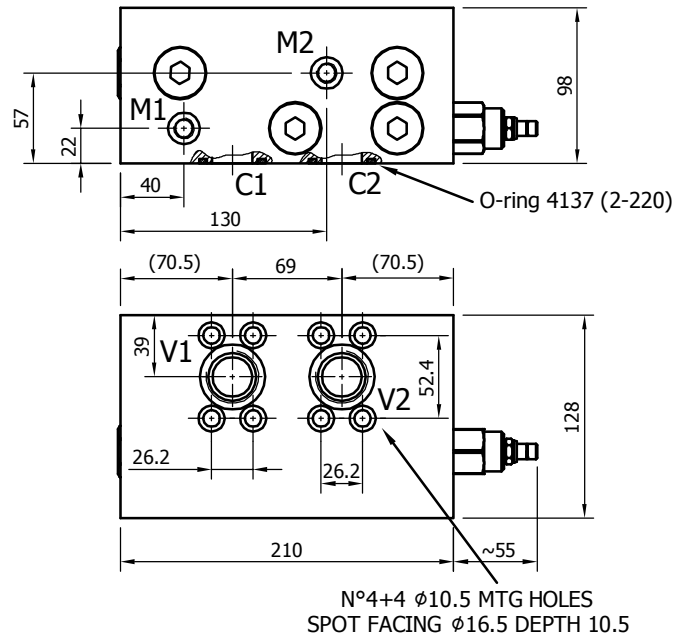

TECHNICAL DATA

RVSAC200.C.D47		
RELIEF VALVE MAXIMUM FLOW	[l/min]	200
MAXIMUM PRESSURE	[bar]	350
RELIEF VALVE SETTING RANGE	[bar]	C (70-420)
STANDARD RELIEF SETTING	[bar]	70
CHECK VALVE MAXIMUM FLOW	[l/min]	160
BLOCK MATERIAL	□	steel
DISTRIBUTOR FITTING	□	D47

Relief cartridge typical pressure rise

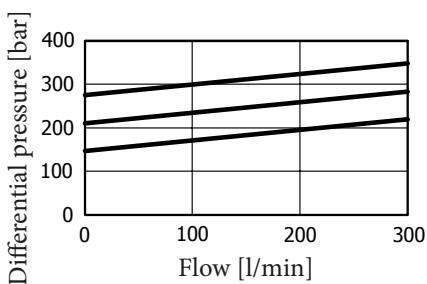

Oil supply flow (from C2 to C1)

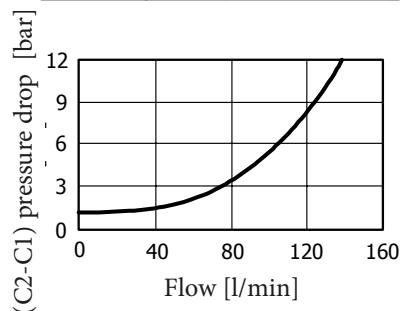

Hydraulic circuit

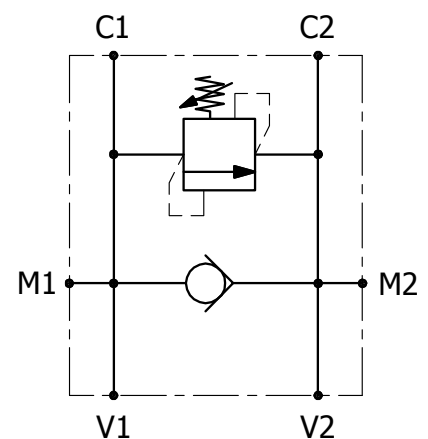

DOUBLE OVERCENTER - OVDA 300

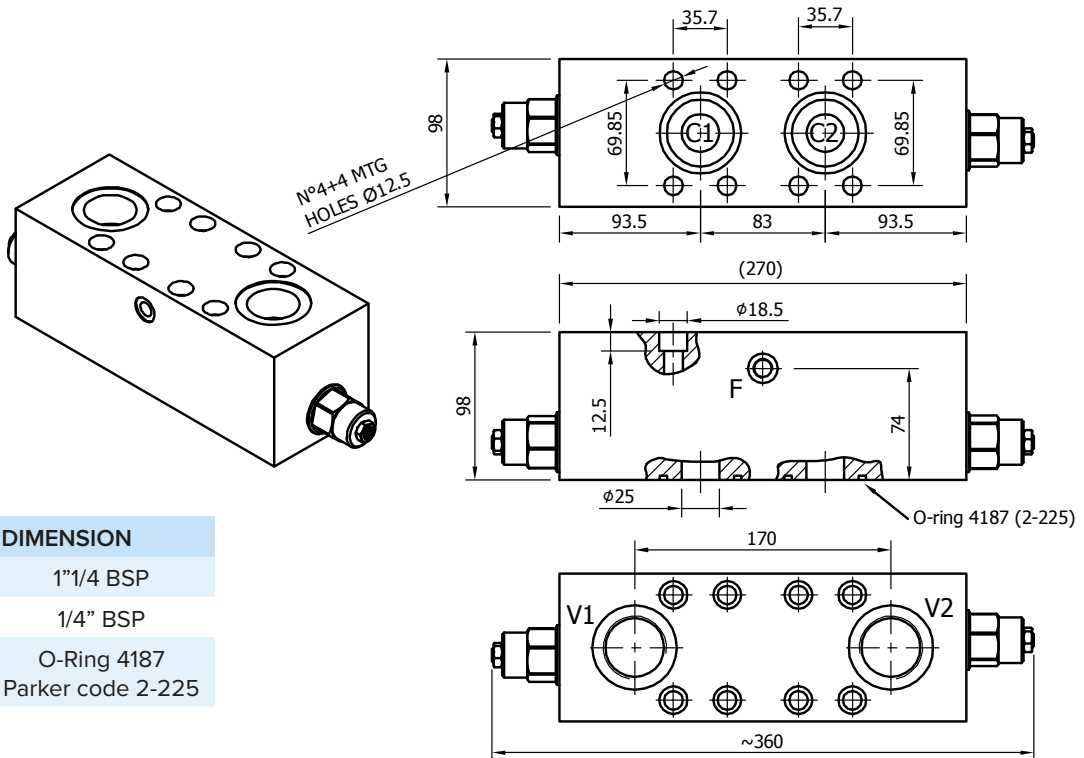

PORTS DIMENSION

V1, V2	1"1/4 BSP
F	1/4" BSP
C1, C2	O-Ring 4187 Parker code 2-225

TECHNICAL DATA

		OVDA.300.1.D75	OVDA.300.4.D75	OVDA.300.2.D75
NOMINAL FLOW	[l/min]	240	240	240
MAXIMUM FLOW	[l/min]	300	300	300
MAXIMUM PRESSURE	[bar]	350	350	350
PILOT RATIO	□	1 (3:1)	4 (10:1)	2 (4.5:1)
RELIEF VALVE SETTING RANGE	[bar]	70-280	140-350	140-350
STANDARD RELIEF SETTING	[bar]	210	210	210
BLOCK MATERIAL	□	steel	steel	steel
DISTRIBUTOR FITTING	□	D75	D75	D75

Cartridge characteristic

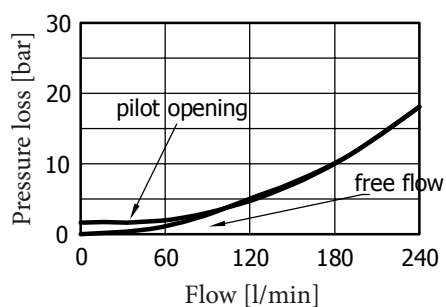

Hydraulic circuit

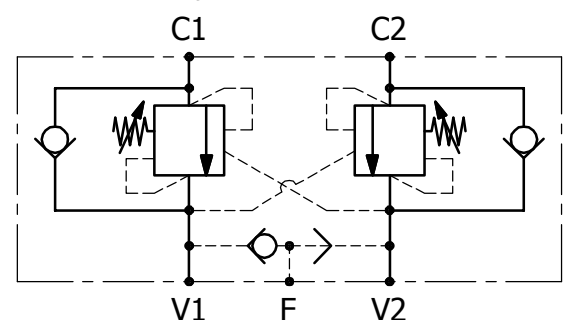

DOUBLE RELIEF - RVDA 200

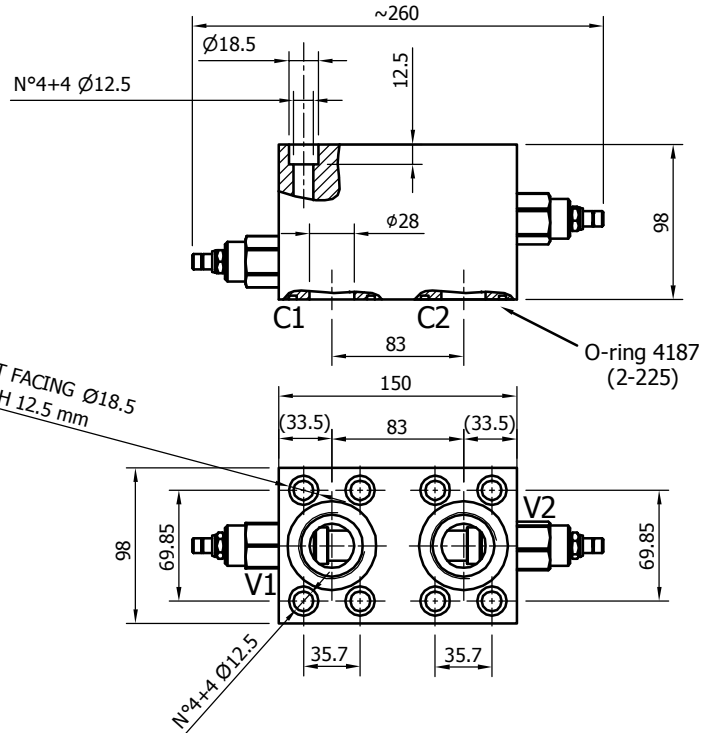
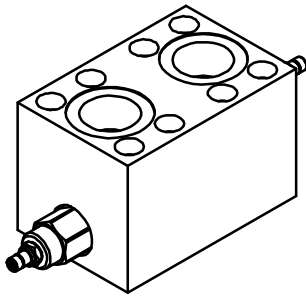

PORTS DIMENSION

V1, V2	1"1/4 BSP
C1, C2	O-Ring 4187 Parker code 2-225

TECHNICAL DATA

RVDA.200.C.D75

RELIEF VALVE MAXIMUM FLOW	[l/min]	200
MAXIMUM PRESSURE	[bar]	350
RELIEF VALVE SETTING RANGE	[bar]	C (70-420)
STANDARD RELIEF SETTING	[bar]	70
BLOCK MATERIAL	□	steel
DISTRIBUTOR FITTING	□	D75

Cartridge typical pressure rise

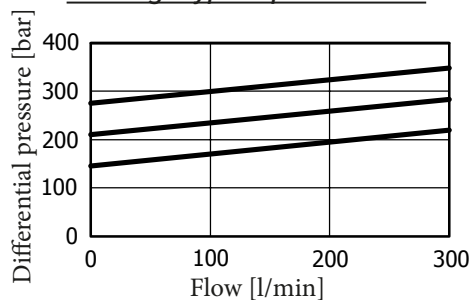

Hydraulic circuit

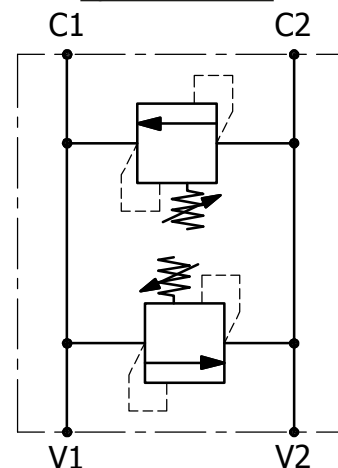

RELIEF & OVERCENTER - ORVSA 200

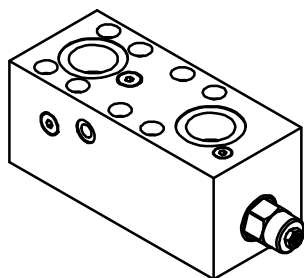

PORTS DIMENSION

V1, V2	1"1/4 BSP
F	1/4" BSP
C1, C2	O-Ring 4187 Parker code 2-225

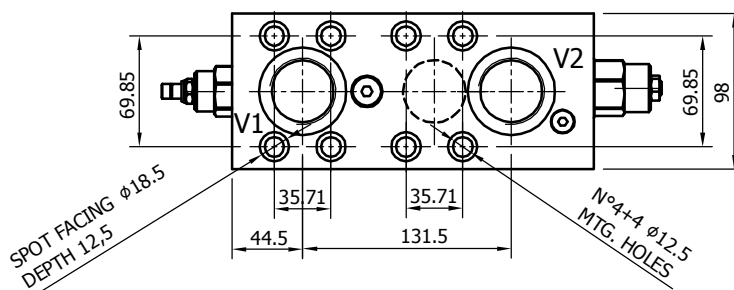
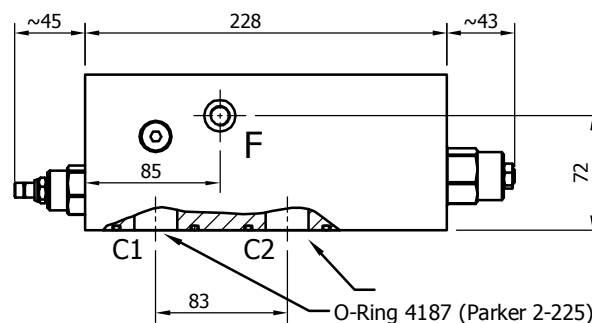

TECHNICAL DATA

		ORVSA.200.1.C.D75	ORVSA.200.4.C.D75	ORVSA.200.2.C.D75
NOMINAL FLOW	[l/min]	240	240	240
MAXIMUM FLOW	[l/min]	300	300	300
MAXIMUM PRESSURE	[bar]	350	350	350
PILOT RATIO	□	1 (3:1)	4 (10:1)	2 (4.5:1)
OVC RELIEF VALVE SETTING RANGE	[bar]	70-280	140-350	140-350
OVC STANDARD RELIEF SETTING	[bar]	210	210	210
RELIEF VALVE SETTING RANGE	[bar]	C (70-420)	C (70-420)	C (70-420)
RELIEF STANDARD SETTING	[bar]	70	70	70
BLOCK MATERIAL	□	steel	steel	steel
DISTRIBUTOR FITTING	□	D75	D75	D75

OVC cartridge characteristic

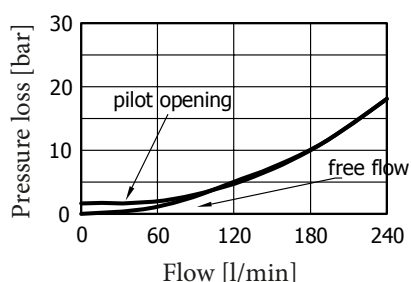

Relief cartridge typical pressure rise

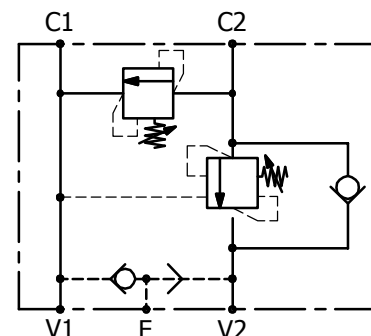
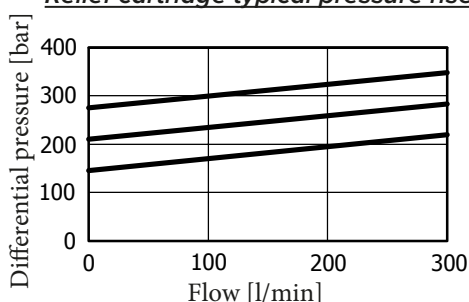

RELIEF & OVERCENTER - DRVSO200EP

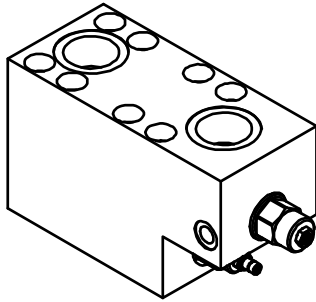

PORTS DIMENSION	
V1, V2	1"1/4 BSP
P	1/4" BSP
C1, C2	O-Ring 4137 Parker code 2-220

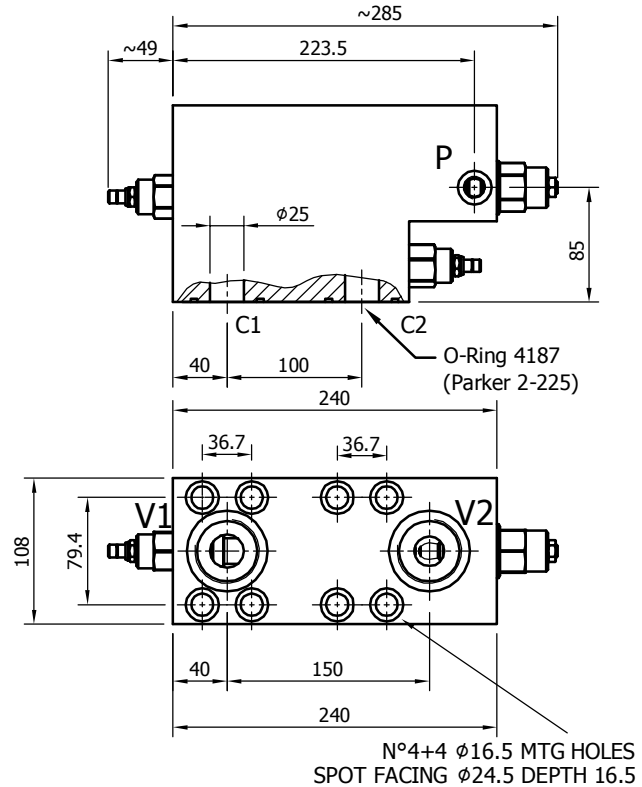

TECHNICAL DATA

		DRVSO200EP.1.C.D75	DRVSO200EP.4.C.D75	DRVSO200EP.2.C.D75
NOMINAL FLOW	[l/min]	240	240	240
MAXIMUM FLOW	[l/min]	300	300	300
MAXIMUM PRESSURE	[bar]	350	350	350
PILOT RATIO	□	1 (3:1)	4 (10:1)	2 (4.5:1)
OVC RELIEF VALVE SETTING RANGE	[bar]	70-280	140-350	140-350
OVC STANDARD RELIEF SETTING	[bar]	210	210	210
RELIEF VALVE SETTING RANGE	[bar]	C (70-420)	C (70-420)	C (70-420)
RELIEF STANDARD SETTING	[bar]	70	70	70
BLOCK MATERIAL	□	steel	steel	steel
DISTRIBUTOR FITTING	□	D75	D75	D75

OVC cartridge characteristic

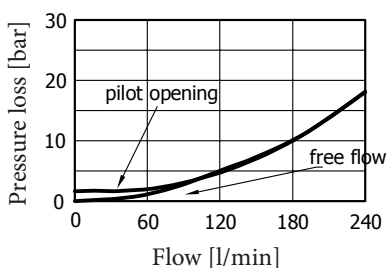

Relief cartridge typical pressure rise

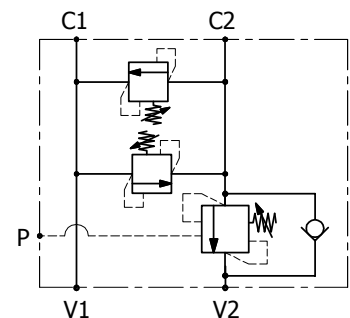
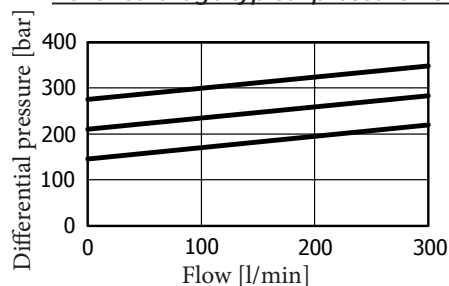

DOUBLE OVERCENTER - OVDA 480

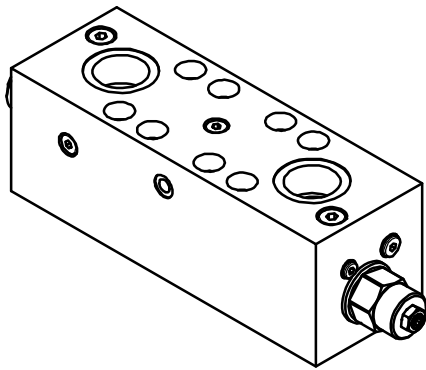

PORTS DIMENSION

V1, V2	1"1/2 BSP
F	1/4" BSP
C1, C2	O-Ring 4187 Parker code 2-225

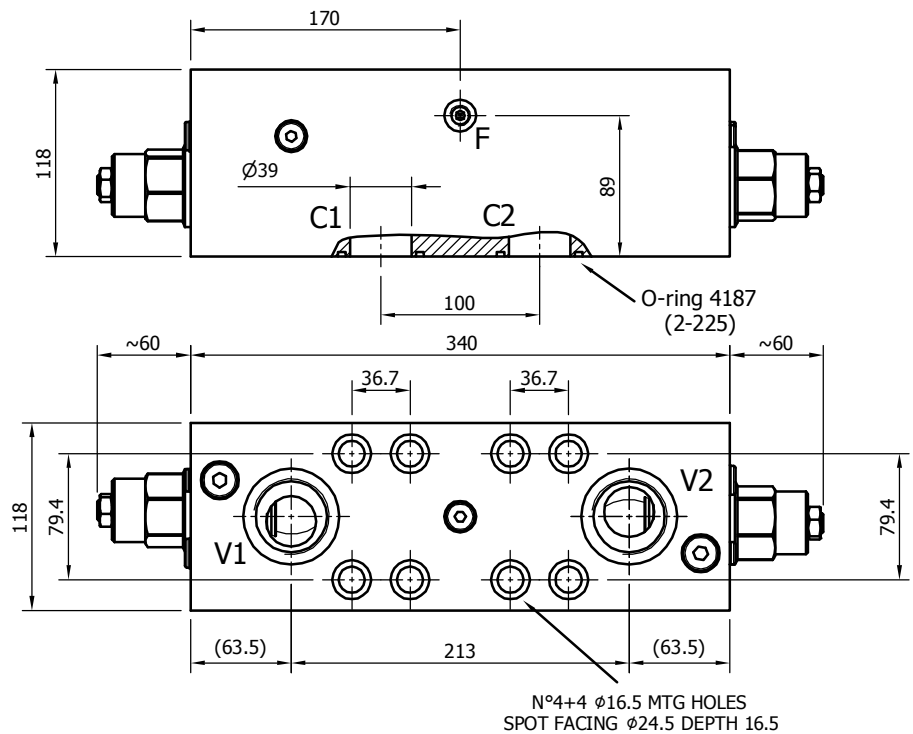

TECHNICAL DATA

		OVDA.480.1.D90	OVDA.480.4.D90	OVDA.480.2.D90
NOMINAL FLOW	[l/min]	480	480	480
MAXIMUM FLOW	[l/min]	600	600	600
MAXIMUM PRESSURE	[bar]	350	350	350
PILOT RATIO	[]	1 (3:1)	4 (10:1)	2 (4.5:1)
RELIEF VALVE SETTING RANGE	[bar]	70-280	140-350	140-350
STANDARD RELIEF SETTING	[bar]	210	210	210
BLOCK MATERIAL	[]	steel	steel	steel
DISTRIBUTOR FITTING	[]	D90	D90	D90

Cartridge characteristic

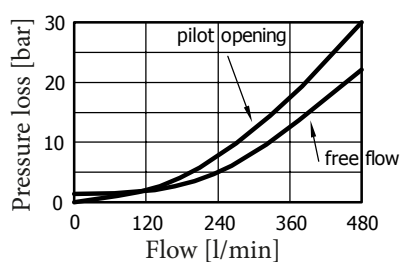

Hydraulic circuit

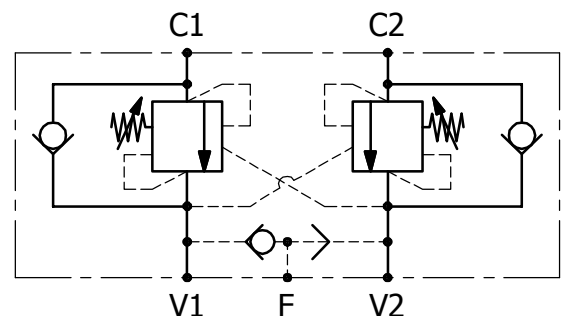

DOUBLE RELIEF - RVDA 380

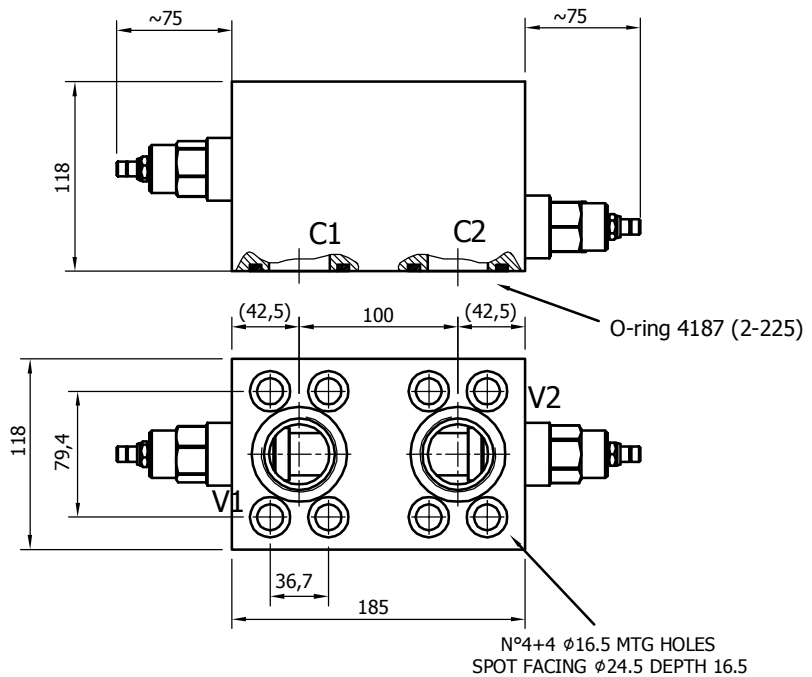
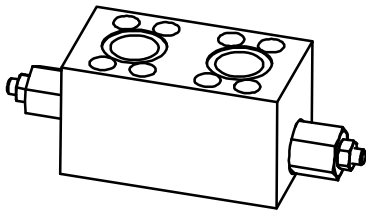

PORTS DIMENSION

V1, V2	1"1/2 BSP
C1, C2	O-Ring 4187 Parker code 2-225

TECHNICAL DATA

RVDA.380.C.D90

RELIEF VALVE MAXIMUM FLOW	[l/min]	380
MAXIMUM PRESSURE	[bar]	350
RELIEF VALVE SETTING RANGE	[bar]	C (70-420)
STANDARD RELIEF SETTING	[bar]	70
BLOCK MATERIAL	□	steel
DISTRIBUTOR FITTING	□	D90

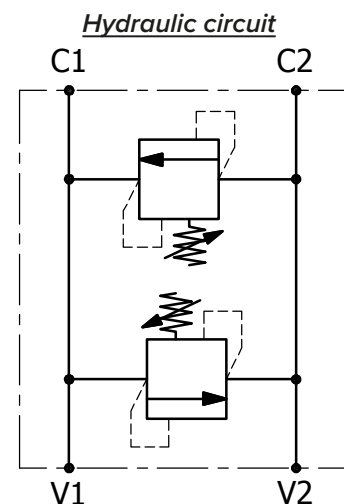
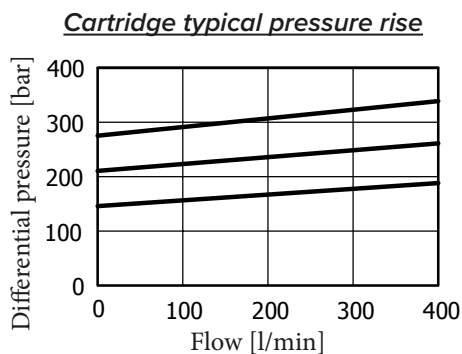

RELIEF & OVERCENTER - ORVSA 480

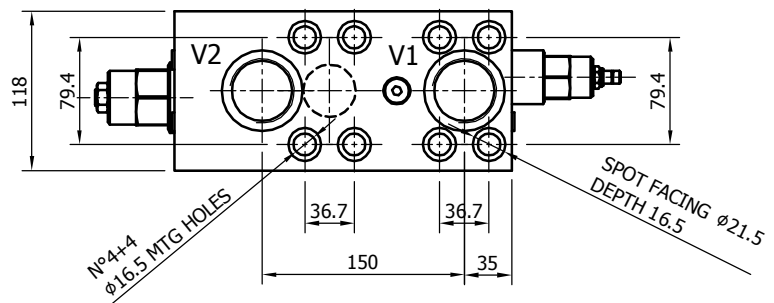
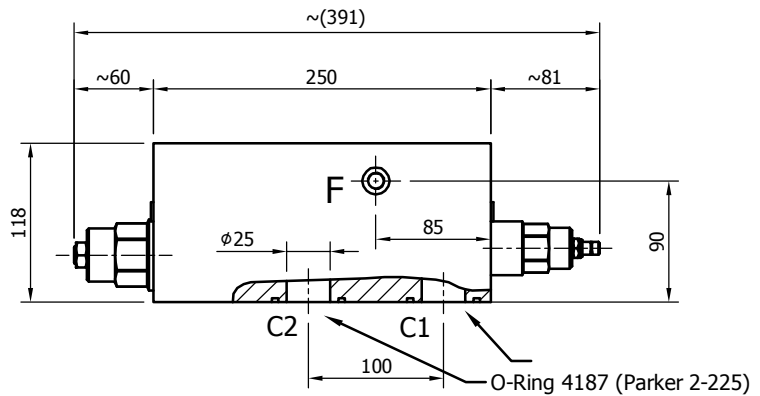
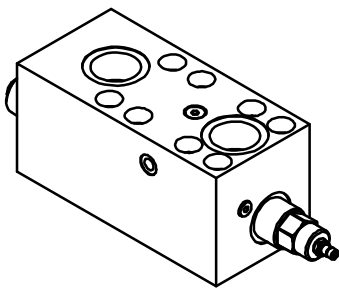

PORTS DIMENSION

V1, V2	1"1/2 BSP
F	1/4" BSP
C1, C2	O-Ring 4187 Parker code 2-225

TECHNICAL DATA

		ORVSA.480.1.D90	ORVSA.480.4.D90	ORVSA.480.2.D90
NOMINAL FLOW	[l/min]	480	480	480
MAXIMUM FLOW	[l/min]	600	600	600
MAXIMUM PRESSURE	[bar]	350	350	350
PILOT RATIO	[]	1 (3:1)	4 (10:1)	2 (4.5:1)
OVC RELIEF VALVE SETTING RANGE	[bar]	70-280	140-350	140-350
OVC STANDARD RELIEF SETTING	[bar]	210	210	210
RELIEF VALVE SETTING RANGE	[bar]	C (70-420)	C (70-420)	C (70-420)
RELIEF STANDARD SETTING	[bar]	70	70	70
BLOCK MATERIAL	[]	steel	steel	steel
DISTRIBUTOR FITTING	[]	D90	D90	D90

OVC cartridge characteristic

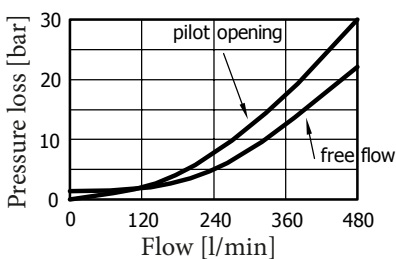

Relief cartridge typical pressure rise

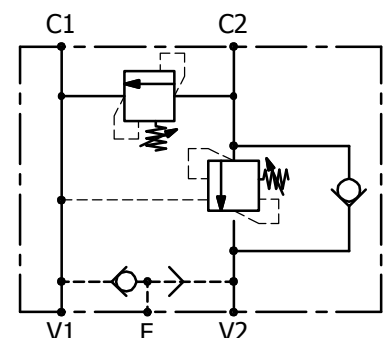
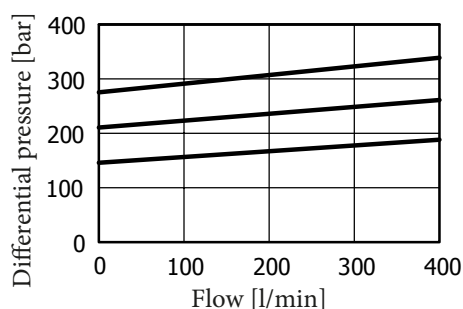

RELIEF & FLUSHING - RVDAP 90

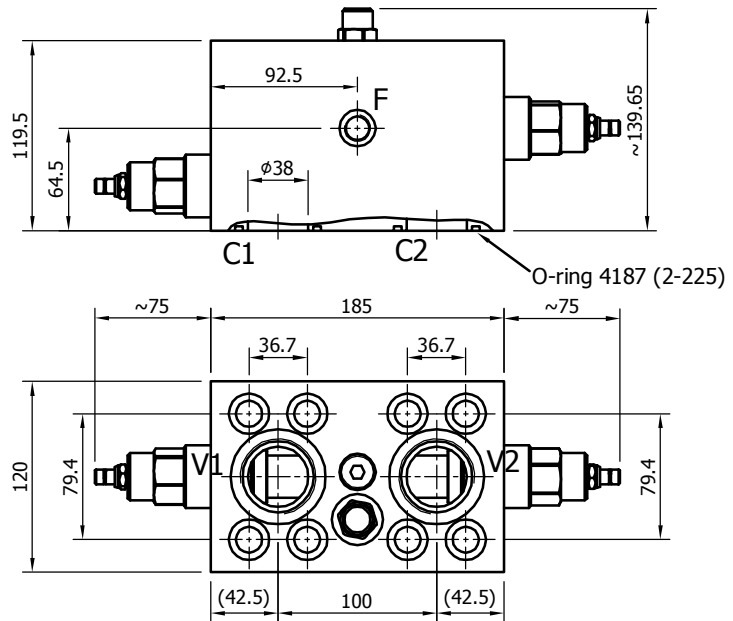
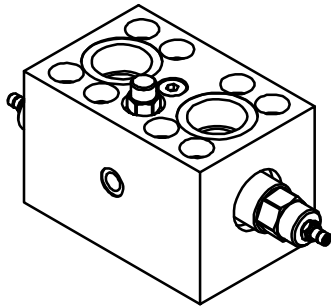

PORTS DIMENSION	
V1, V2	1" BSP
F	3/8" BSP
C1, C2	O-Ring 4187 Parker code 2-225

TECHNICAL DATA

		RVDAP90.C.D90
RELIEF VALVE MAXIMUM FLOW	[l/min]	380
RELIEF VALVE SETTING RANGE	[bar]	C (70-420)
STANDARD RELIEF SETTING	[bar]	70
MAXIMUM FLUSHING FLOW	[l/min]	80
MAXIMUM PRESSURE	[bar]	350
BLOCK MATERIAL	□	steel
DISTRIBUTOR FITTING	□	D90

Hydraulic circuit

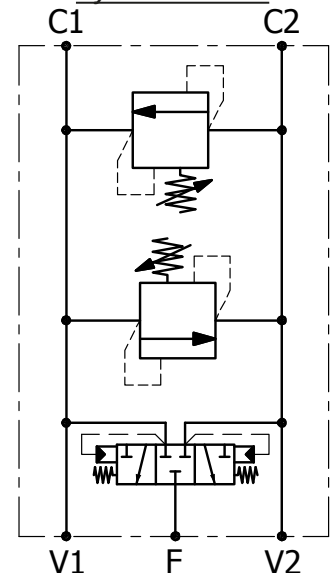

Relief cartridge typical pressure rise

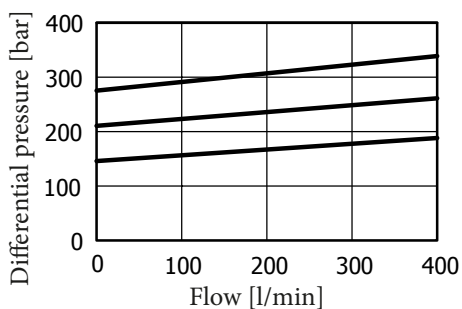

Oil supply flow (from C2 to C1)

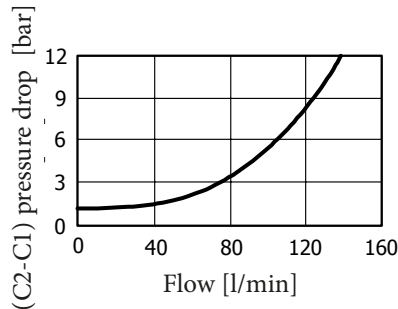

VALVES - ORDERING CODE

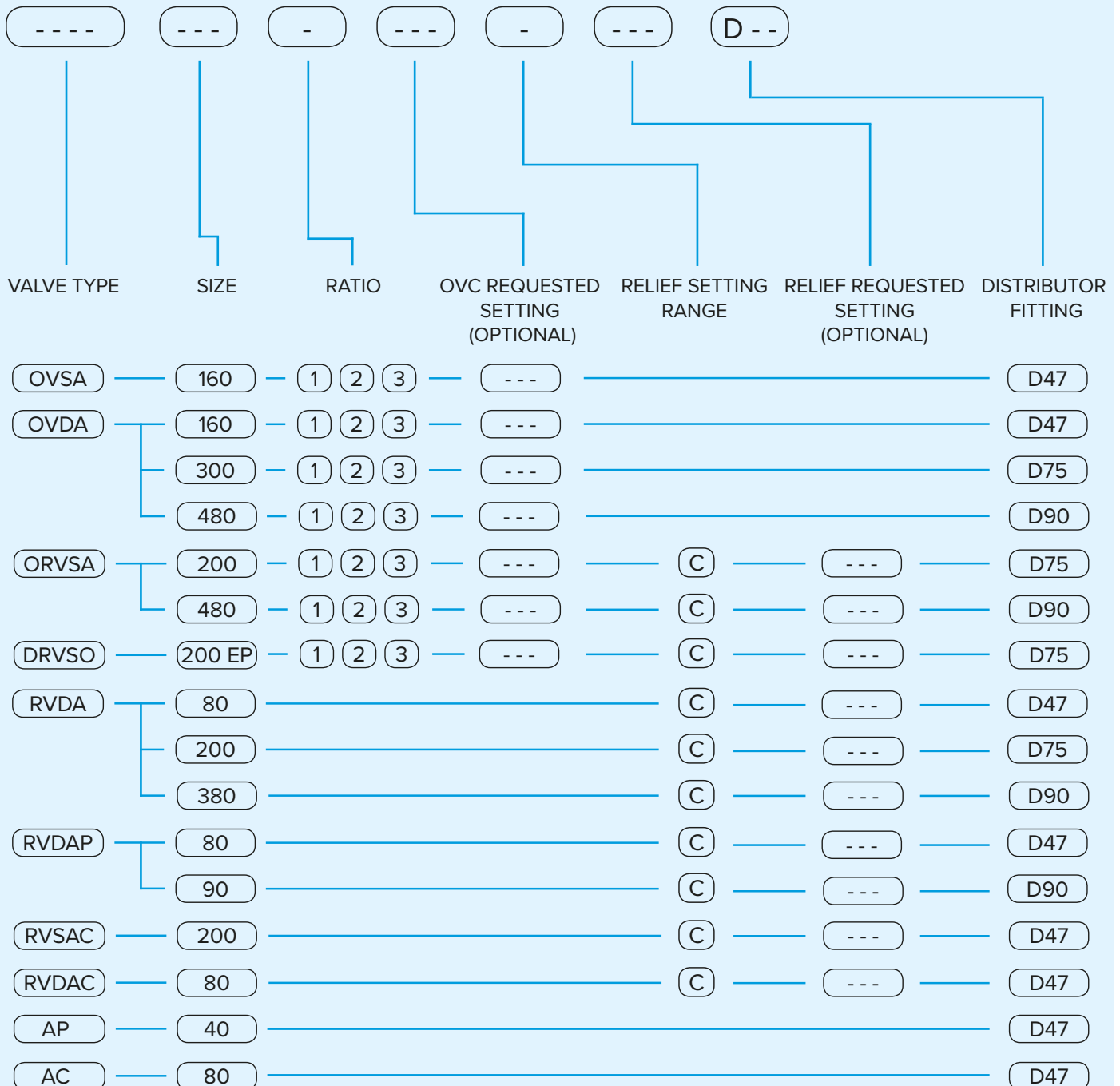

EXAMPLES:

OVDA 160 1 200 D47
 AP 40 D47
 ORVSA 480 3 250 C 200 D90
 ORVSA 200 1 C D75

CONTACT US

CONTACT US

Italgroupp S.r.l.
 Via Pacinotti 20/22
 41010 - Gaggio di Piano (Modena) – Italy

Tel. +39 059 92 42 57
 Fax +39 059 92 01 13
 e-mail: italgroup@italgroup.eu
 internet: <http://www.italgroup.eu>

REACH US



Europe

Austria
Belgium
Croatia
Czech Republic
Cyprus
Denmark
Faroe Islands
France
Finland
Germany
Greece
Iceland
Italy
Netherlands
Norway
Poland
Portugal
Russia
Slovenia
Spain
Sweden
Switzerland
Turkey
Ukraine
United Kingdom

Asia

China
Hong Kong
India
Indonesia
Iran
Israel
Philippines
Russia
Belarus
Singapore
South Korea
Thailand
Taiwan
United Arab Emirates
Vietnam

Africa

Egypt
South Africa
Tunisia

America

Argentina
Brazil
Canada
Chile
Mexico
Peru
USA
Colombia

Oceania

Australia
New Zealand

