

**ULVT
BLVT
ULVTK
BLVTK**

Operating instructions

translation



ULVT

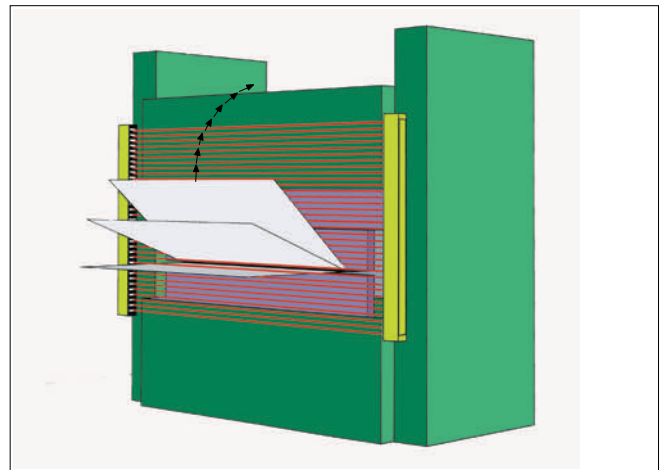

BLVT (with blanking features)

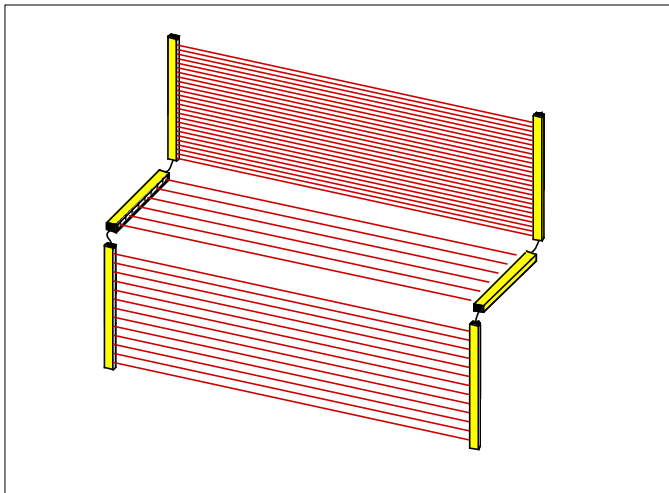

ULVTK / BLVTK (Cascading of Light Curtains)

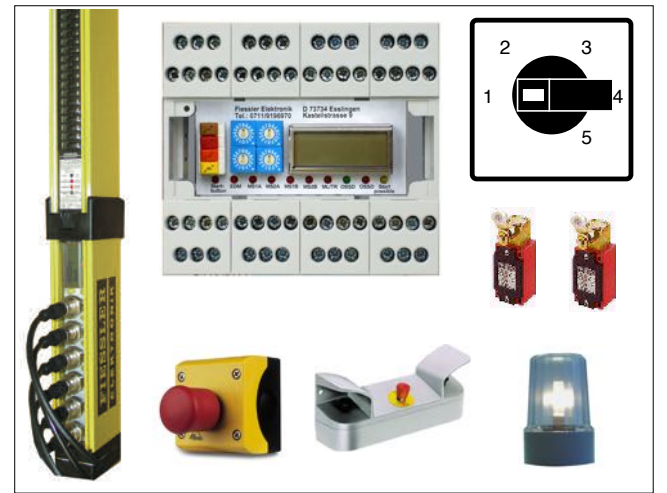

Muting, cycle operation with safety switching units as option

INHALT:

Safety instructions



Application notes

Installation

Electric Connection

Commissioning

Specifications Accessories



For over 50 years,

we have proved to be specialists in the area of optoelectronics.

Our experience is your gain. Tell us your problems, and we will be pleased to advise you.



Safety switching mats

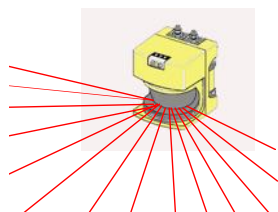

Area laser Scanner

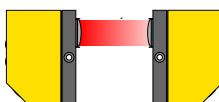

Single-Beam safety light barrier with extended range (up to 150 m)

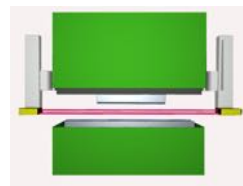

Press Brake Protection System AKAS®

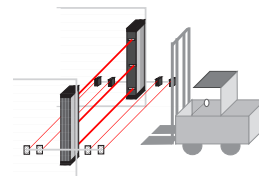

Differentiation between man and machine by the use of the Muting function

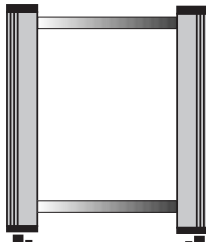

two-beam light grid range until 60 m

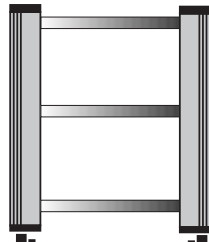

3- and multi-beam light grid range until 60 m

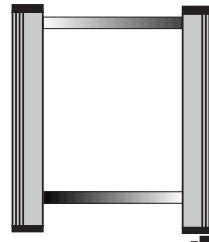

two-beam light grid with transmitter/receiver unit and mirror unit, range up to 10 m

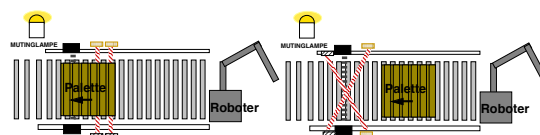

Outgoing muting
Differentiation between man and material

Cross muting
Differentiation between man and machine / material

Fiessler Elektronik GmbH & Co.KG
DE-73773 Aichwald

Phone: ++49(0)711-91 96 97-0
Fax: ++49(0)711-91 96 97-50
Email: info@fiessler.de
Internet: www.fiessler.de

Representations in all major industrial nations.



We also invest in environmental protection

Sector	Contents	Page
1	Safety Instructions 	5
1.1	Prerequisites for the utilisation of the safety light curtains	5
2	Terminology	6
3	System Description and Technical Data	8
3.1	Features	8
3.2	Application Areas	8
3.3	Structure and Function	9
3.4	Tables: Protective fields, constructional lengths, ranges, resolutions, beam spacing, number of beams	9
3.5	LED-displays (in general)	10
3.6	Operating modes selector (with/without restart interlock, with/without contactor check, equivalent/antivalent outputs)	10
3.7	Technical data	11
3.8	Dimensions drawing (Light curtain and standard fastening brackets)	12
4	Installation	13
4.1	Response times ULVT, BLVT, cascaded systems and optional safety switching units	13
4.2	Safety distance from the hazardous areas	14
4.2.1	- vertical protection for hazardous areas (≤ 40 mm resolution)	14
4.2.2	- horizontal protection for hazardous areas	15
4.2.3	- vertical protection for hazardous areas by light grids (> 40 mm resolution and single beams)	16
4.3	Construction requirements	17
4.3.1	- Installation without additional screening	17
4.3.2	- Protection against reaching over or under barriers	17
4.3.3	- Protection against avoiding barriers through cascading or additional screening	17
4.3.4	- Distance from reflective surfaces	18
4.3.5	- Arrangement of two safety light barriers	18
4.4	Mounting and Adjustment	19
4.4.1	Adjustment Instructions with standard fastening brackets / Isolated mounting on EMV disturbances	19
4.4.2	Option: angular brackets (dimension drawing included)	20
4.4.3	Option: rubber-metal connection (to avoid intense vibrations)	21
4.4.4	Option: multi-sided screening by using tilted mirrors (dimension drawing included)	21
4.4.5	Option: Assembly columns / Shock Protection (dimension drawing included)	23
5	Electric Connection ULVT / BLVT	25
5.1	Integrated connector plug	25
5.2	Electric connection ratings	25
5.3	Connectors	25
5.4	Connection examples - without optional safety switching units	26
5.4.1	ULVT 500/2R : connecting advice	26
5.4.2	Safety mode with restart interlock/ with valve or contactor check	26
5.4.3	Safety mode without restart interlock/ without valve or contactor check	26
5.4.4	SPS drive	26
6	Commissioning	27
6.1	Commissioning	27
6.2	Adjustment instructions / LED-displays	27
6.3	Trouble-shooting / LED-displays	28

chapter	contents	Page
7	BLVT-Blanking functions (Blanking)	29
7.1	Safety Advices	29
7.2	Typical applications of the different blanking functions	30
7.3	Important instructions and available resolutions of the different blanking functions	31
7.4	Programmer units for programming the blanking functions	32
7.5	Programming up to 5 different blanking patterns and activating them via selector switch	32
8	Cascading of Light curtains	33
8.1	Additional safety advices for cascaded Light grids	33
8.2	Application examples	33
8.3	How to utilize and to combine the systems (Cat. 4 und Cat. 2)	34
8.4	Order designations	34
8.5	Response time (examples)	35
8.6	Safety distance (example)	35
8.7	Installation	36
8.8	Connection	36
8.8.1	Connection example 1	36
8.8.2	Connection example 2	37
8.9	Commissioning	38
8.10	Commissioning / Protective Field States and LED- Displays	39
9	Additional functions with safety switching units	40
10	Accessories and Spare Parts	41
11	Notes	42
12	Service / Maintenance / Warranty	46
13	Declaration of conformity	47
14	Additional safety products	48



All safety instructions are marked with this symbol and must be observed under all circumstances!



The safe operation of the entire system can only be ensured through adherence to these operating instructions and the corresponding accident prevention regulations. These operating instructions comprise part of the light barrier and must be retained at the installation site.

All specifications of these operating instructions must be observed at all times. These operating instructions provide the user with important information concerning the proper use of the ULVT/BLVT safety light barriers. .

When using safety light barriers, the effective standards and guidelines must be observed! The local authorities or trade associations will provide you with the relevant information. Currently effective conditions and the regulations of the trade associations must also be adhered to.

Qualified personnel. Installation, commissioning and maintenance must only be carried out by qualified personnel.

Danger sign When operating a machine with ULVT/BLVT ... safety light barriers, it must be ensured that nobody is located within a hazardous area. A danger sign to this effect must be attached to the machine.

Light barriers do not provide protection from flying objects resulting from the operation of the machine.

When using the ULVT/ BLVT with an external switching unit or similar succeeding controls, it must be ensured by appropriate, either contructional or organisatorial means, that at least once within 24 hours, a close-down of the light curtain by intentional interruption of testing of the protective field takes place in order to prevent any unnoticed accumulation of mal-functions.

Caution, daily inspection (after 24 hours at the latest): Before the start of a shift, the light barrier must be checked as follows: Using the test rod*, the light barrier is to be interrupted on the transmitting side from start to finish in such a way that the light field is only covered by this part. The green LED (or the yellow LED in the operating mode with restart interlock) must not light up from start to finish.

* The diameter of the test rod must correspond to the obstacle size specified on the nameplate of the receiving side. Acht

When using the BLVT Blanking features, the additional safety advices and all other instructions in chapter 7 must be observed!

When using the Cascading features, the additional safety advices and all other instructions in chapter 8 must be observed!

The **safety distance** between the protective field and the hazardous area must be large enough to ensure that when penetrating the protective field, the hazardous areas cannot be reached before the hazardous movement is interrupted or ended.

Access to the hazardous area must only be possible through the protective field (reaching under, over or around the field must not be possible).

Passing through the light barrier must only be possible if the restart interlock is activated subsequent to the light barrier being interrupted.

A new command to activate the next hazardous movement must only be implemented via a dead-man switch. It must not be possible for this start button to be actuated from within the hazardous area: The switch must be located at a point from which the accessible area can be viewed without obstruction.

The hazardous state of a machine must be interrupted by the sensory function of the ESPE.

The unintentional repetition of a hazardous movement must be prevented by the appropriate safety facilities.

- The **safety category** (Type 4) of the accident-prevention light barrier should be at least the same as safety category of the machine.

Approval:

Approval of the construction and the tests should be carried out by competent personnel who are in possession of all information provided by the supplier of the machine and the BWS.

Annual inspection:

The operator must ensure that a competent person is assigned with the task of inspecting the light barrier on a yearly basis. This person may, for example, comprise an employee of the light barrier manufacturer or of the operator.

Maintenance information: The ULVT/BLVT... system is maintenance-free depending on the construction. (This does not, however, release the obligation to carry out the prescribed **annual inspection pursuant to EN 61496, ZH 1/281 and/or ZH 1/597.**) On request by the customer, the Fiessler Elektronik company will carry out the **initial approval and annual inspection**. In addition, customer-training seminars concerning the implementation of the annual inspection are held at regular intervals.

The protective panels in front of the transmitter and receiver should simply be cleaned at regular intervals with a solvent-free detergent. Solvents can damage the plexiglass panels of the transmitter and receiver. **As an alternative, light barriers with silicate glass are available.**

Start interlock

Subsequent to commissioning and/or a power interruption, the start interlock prevents a "re-release". A re-release is only possible once the protective field has been interrupted and reactivated.

Response time

The time period between penetration of the protective field and the switching process.

Blanking

The Blanking features provide the temporarily "skipping" or "disabling" of selected areas of the the protective field. By doing this, parts of tools or machinery may reach into the protective field without reducing the function of the machine. (please refer top chapter 7 BLVT).

EPSE Type 4

The ULVT/BLVT... safety light barriers comprise photo-electric guards. These devices are characterized by the fact that when the **protective field** generated by the transmitter and receiver is interrupted, a hazardous movement is interrupted or prevented.

One-cycle (two-cycle operating mode)

Subsequent to one (two) penetrations of the protectvie field, the machine automatically performs an operating cycle and then waits for a maximum 30 seconds for one (two) penetrations.

If the time period exceeds 30 seconds, the restart interlock is activated.

Installation range (Fig. 6/1)

The minimum and/or maximum permissible distance between the transmitter and receiver. The permissible detection range is specified on the ULVT receiver.

Obstacle size (Fig. 6/1)

The obstacle size indicates the minimum obstacle diameter that will definitely interrupt a hazardous movement through the safety light barriers.

The following obstacle sizes are provided by the beam distances for the ULVT... safety light barriers:

min./max. detection range	0,3 m / 7 m	0,3 m / 24 m
min. obstacle diameter	14 mm	30 mm
min./max. protection field height	100 mm / 1900 mm	100 mm / 3000 mm

Table 6/1a detection range, obstacle size, protective field height

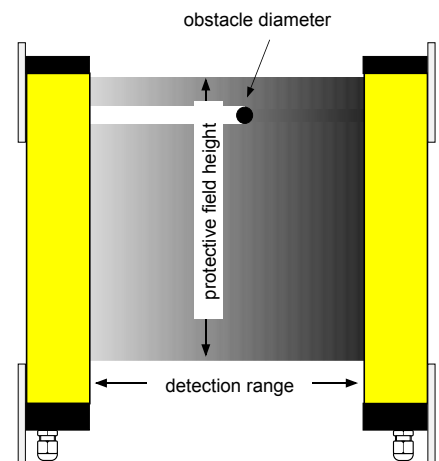

fig 6/1 detection range, obstacle size, protective field height

Muting

Temporary and safe bridging of the ULVT/BLVT safety light barriers during a material movement, e.g. into and out of a manufacturing cell, or in high-bay storage. Reliable differentiation between man and material flow is ensured.

Overrun

The section of hazardous movement which occurs after penetration of the protective field.

Overrun traverse (Fig. 6/2)

The path traversed during the run-on period (e.g. path of a ram, path of a point on a roller surface).

Overrun period

Duration of the run-on period.

Protective field height (Fig. 6/1)

Height of the protective field generated by the transmitter and receiver.



Bild 6/2 Ssafety distance and overrun traverse

Safety mode

When the protective field is interrupted, the switching outputs are blocked, then automatically released subsequent to re-release of the protective field.

Self-monitoring

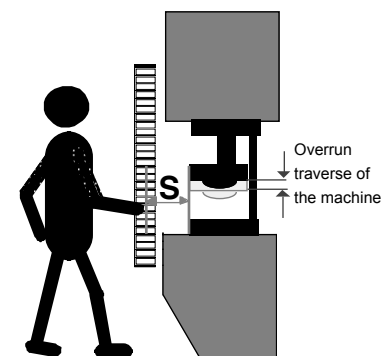
The automatic response of the photo-electric guard in the event of an internal malfunction.

Safety distance (Fig. 30/2)

The minimum distance S between safety light barrier and the nearest hazardous area, required in order to prevent injuries. In order to establish the minimum safe distance, the formulas from standard EN 999 / ISO 13855, the machine-specific EC standards and the effective ZH guidelines are to be used.

Safety category 4

The ULVT safety light barriers belong to safety category 4 as per EN 945-1 and IEC 61496 / EN 61496.

Devices of safety category 4 comprise self-monitoring photo-electric guards and represent the highest safety class for photo-

Beam spacing

The distance (gap) between the centres of the individual lenses on ULVT/BLVT... safety light barriers is called the beam distance/ beam spacing. The ULVT/BLVT... safety light barriers are supplied with a lens grid of 7.5 mm, respective and 14mm.

Valve or contactor control

Prior to each release of the switching outputs, the contactor control identifies whether the connected switching elements (relays, contactors or valves) have fallen. Only when this is so can a new release of the switching inputs be performed. This also prevents the dangerous failure of the switching elements (relays, contactors, valves) of the hazardous movement.

Restart interlock

The restart interlock prevents the automatic release of the switching outputs subsequent to the interruption and reactivation of the protective field (e.g. due to walking through the protective field).

3.1 Features

The ULVT/BLVT safety light curtains are **characterized** by the following:

- **Safety category 4**
4 (EN ISO 13849-1:2008) and EN 61496 or IEC 61496
PL e (EN ISO 13849-1:2008)
SIL3 (EN 62061:2005)
- **contactor check and restart interlock:** Integrated functions activated via DIP switch
- **Direct connection of contactors / valves,** switching capacity of 0.5 A / 24 V
- **beam spacings:** 7,5mm, 14 mm, 100mm, 200mm, 300mm, 400mm, 500mm
- **detection ranges.** 7m, 24, and 60m
- 2 to 247 beams at **protective field heights** of 100 mm to 1900 mm
- Smallest safety distance through **short response times:** 4ms to 37ms, depending on construction length
- **Reverse-read semi-conductor outputs** with line interruption, short-circuit and cross-circuit monitoring
- **11 different blanking patterns** (BLVT only). Blanking of obstacles with reliable safety.
- **cascading:** for protecting a hazardous area on more than one side, up to three light curtains may be connected in series.

3.2 Application areas

The ULVT/BLVT safety light barriers are designed to **protect hazardous areas, for cordoning off areas, and to prevent access.**

Protection of **fingers, hands and body**, for example in

- Presses for the processing of metal, wood, plastic, rubber, leather and glass
- Filter presses
- Folding and bending machines
- Injection moulding machines
- Processing centres and welding presses
- Automatic placement machines
- Robots
- Palletizing machines

Using **tilted mirrors**, the protective field can be "wrapped around" a hazardous area, thus ensuring protection from several sides.

Muting operation and cycle mode are available using safety switching units as option. (see chapter 9).



Bild 8/1 Protecting in hazardous areas



Bild 8/2 cordoning off areas

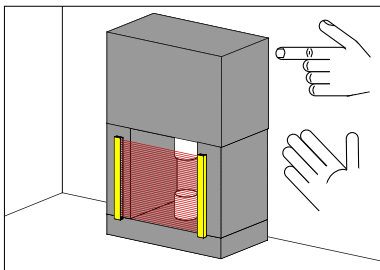

Bild 8/3 Restricting access to areas

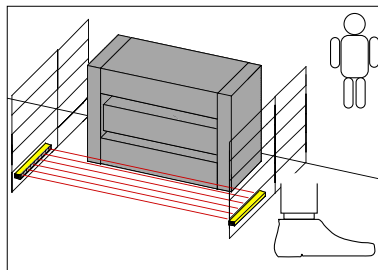

Bild 8/4 Restricting access to areas by wrapping around the protective field by tilted mirrors

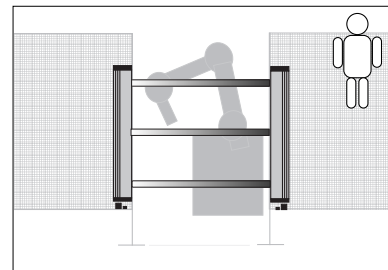

Bild 8/5 Blanking functions

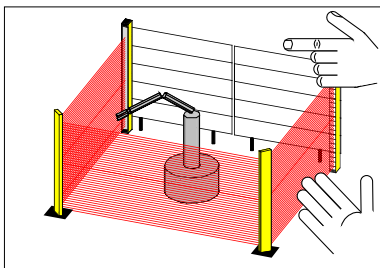

Bild 8/6 Area protection with Muting features

3.3 Structure and function

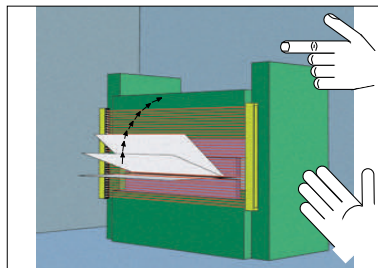
The ULVT/BLVT safety light barriers consist of two components: The light transmitter and receiver. The distance between the two components and the installation height are calculated from the width and height of the protective field (Fig. 9/1).

Due to its modular structure, protective field heights between 100 mm and 1900 mm can be attained (Table 8/1).

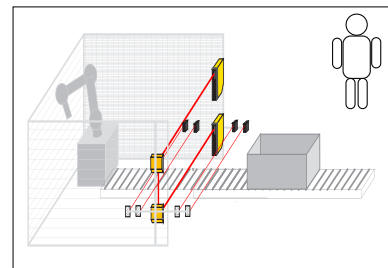
The transmitter and receiver are synchronous, i.e., at any one time, only one light beam and one receiving element are active. Synchronization is implemented by the first light beam and the first receiving element. An electric connection between the transmitter and receiver is therefore not required.

The transmitter generates infrared light beams which are switched on an off in quick succession. The parallel light beams at a distance of 7.5 mm are assessed by two single-chip microcontrollers. The beam distance produces a definition of 14 mm. (see table 9/2).

If an object is located within the protective field, i.e., at least one of the light beams is blocked out, the two outputs of the receiver will stop the hazardous movement of the machine and/or prevent a start. In the operating mode with restart interlock, the machine can only be restarted by actuating the start button when the protective field is free again.

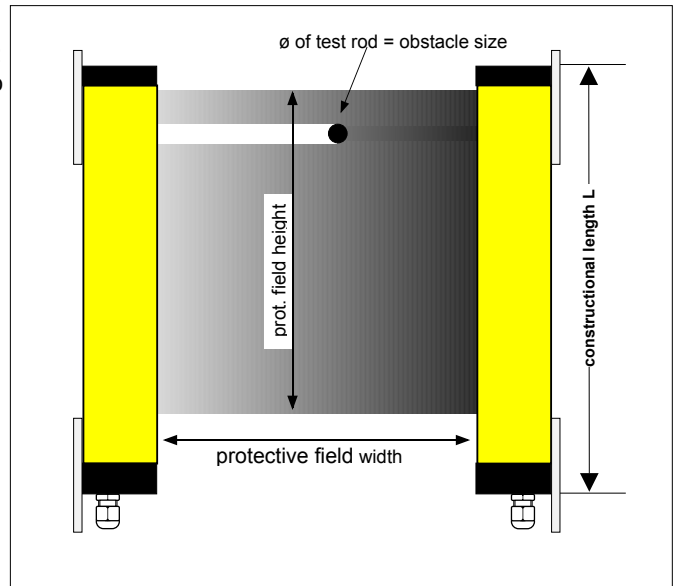

fig. 9/1 transmitter and receiver form the protective field

3.4 Protective field height, constructional length, ranges, resolutions, beam spacings and number of beams

Table		Finger protection resolution 14 mm	Hand protection resolution 30 mm	Pedestrian Access Protection	Pedestrian Access Protection	Pedestrian Access Protection	Pedestrian Access Protection	Pedestrian Access Protection	Pedestrian Access Protection	
		Range 7 m / 10m	Range 24 m / 30m*	Range 24 m / 30m*	Range 24 m / 30m*	Range 24 m / 60 m*	Range 24 m / 60 m*	Range 24 m / 60 m*	Range 8 m	
Protective Field height (mm)	Constr length L (mm)	Beam spacing 7,5 mm No. of beams	Beam spacing 14 mm No. of beams	Beam spacing 100 mm No. of beams	Beam spacing 200 mm No. of beams	Beam spacing 300 mm No. of beams	Beam spacing 400 mm No. of beams	Beam spacing 500 mm No. of beams	Beam spacing 500 mm No. of beams	
100	196	13	7	-	-	-	-	-	-	
200	296	26	14	3	2	-	-	-	-	
300	396	39	21	4	-	2	-	-	-	
400	496	52	28	5	3	-	2	-	-	
500	596	65	35	6	-	-	-	2	-	
500	650	ULVT500/2R: beam deflection via separate passive mirror unit. Wiring required on one side only.							2	-
600	696	78	42	7	4	3	-	-	-	
700	796	91	49	8	-	-	-	-	-	
800	896	104	56	9	5	-	3	-	-	
900	996	117	63	10	-	4	-	-	-	
1000	1096	130	70	11	6	-	-	3	-	
1100	1196	143	77	12	-	-	-	-	-	
1200	1296	156	84	13	7	5	4	-	-	
1300	1396	169	91	14	-	-	-	-	-	
1400	1496	182	98	15	8	-	-	-	-	
1500	1596	195	105	16	-	6	-	4	-	
1600	1696	208	112	17	9	-	5	-	-	
1700	1796	221	119	18	-	-	-	-	-	
1800	1896	234	126	19	10	-	-	-	-	
1900	1996	247	133	20	-	-	-	-	-	

Table 9/2 Available standard sizes



* = At 60m version: Operation of > 15-60m. No operation <15m distance from transmitter to receiver.
* = At 30m version: Operation of > 15-30m. No operation <15m distance from transmitter to receiver.

3.5 LED-displays (also refer to chap. 6.2 and 6.3 Commissioning and Trouble-Shooting)

Several LEDs on the receiver indicate the current operating status (Fig. 10/1). If the system test detects an internal or external fault, the machine will be switched off immediately and the LEDs on the receiver and/or transmitter (if the fault lies within the transmitter) indicate the fault status to the user by quick flashing.

When a fault is present, the flashing LEDs together with a fault code provide visual output of the detected fault and display in the diagnostics device.

Transmitter		Receiver	
Yellow ON	Transmitter active	Green ON	light barrier free
Yellow OFF	Transmitter off	Red ON	light barrier interrupted
Fast Yellow flashing ca. 4 x /s	fault	Orange ON	contamination (no reserve)
Slow Yellow flashing ca. 1 x /s	cascading only: succeeding receiver: interrupted	Yellow ON	Start prompt
		fast orange flashing ca. 4 x /s	fault
		fast yellow flashing ca. 4 x /s	fault
		slow orange flashing ca. 1 x /s	BLVT only: reduced resolution
		slow yellow flashing ca. 1 x /s	BLVT only: reduced resolution

Bild 10/1 LED indicate the operating and/or fault status

3.6 Operating mode switches

The DIP switches in the connector cover enable the following operating modes to be selected:

- Safety mode with / without restart interlock
- With / without contactor check
- equivalent / antivalent outputs (Fig. 9/1)

In the condition when delivered, the preset operating mode comprises safety mode with:

restart interlock,
contactor check and
equivalent outputs.

Caution!

The operating mode may only be selected when no voltage is present. If the DIP switches are actuated during operation, the light barrier will switch off the outputs and go to locking status. This is indicated by flashing of the yellow and orange LEDs. Locking status will only be ended once the power supply has been switched off.



Bild 10/2 The operating modes can be set using the DIP switches. The condition when delivered is shown here.

The switchgears ULSG, LSUW NSR 3-1-K and LSUW N1-Muting K are available for additional functions such as potential-free output contacts or muting (Refer to Section 8 for further information and electric connection).

without contactor control	with contactor control	
		The operating mode with contactor control serves to monitor the driven succeeding contactors. After each interruption of the light path and before each release of the switching outputs, it is checked whether the succeeding contactors have fallen. Only then will a new release be possible. If the contactors do not respond within 300 ms, the light barrier switches off the outputs and goes into locking status.
without restart interlock	with restart interlock	With the operating mode with restart interlock selected, a button must be connected to the start button input for a start release of the operating movement.
		When the protective field is free, the yellow LED lights up on the receiver as a start prompt. Only once the start button has been pressed will the outputs of the ULVT/BLVT be switched to active.
equivalent outputs	antivalent outputs	In the equivalent outputs operating mode , both PNP outputs are failsafe and monitored internally for short-circuits and cross-circuits. With a free light path, both outputs are high (+24 V). In the antivalent outputs operating mode , output 1 is high (+24 V) and output 2 low (0 V) when the light path is free. Output 2 is not failsafe in this operating mode. This operating mode is only permissible in conjunction with the safety switchgears LSUW NSR 3-1K, LSUW N1-Muting K, or another safe sequential phase control device which monitors output 2!
outputs are fail safe	output 2 = not fail-safe!	

Table 10/3 programming of operation modes

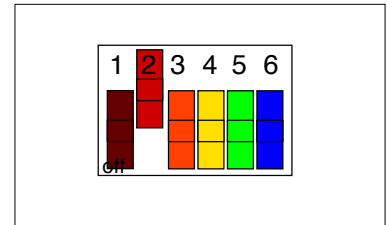
3.7 Technical data
Characteristics
ULVT/ BLVT

Safety Category	4 (EN ISO 13849-1:2008) and EN 61496 or IEC 61496
Performance Level	PL e (EN ISO 13849-1:2008)
Safety Integrity Level	SIL3 (EN 62061:2005)
Protective field heights	100 mm ... 1900 mm (depending on number of beams) refer to table in chapter 3.4 (optional until 3000 mm)
Protective field width (Range)	0,3... 7 m, 0,3...24 m / 60m (depending on design) refer to table in chapter 3.4 (ULVT500/2R:0,3...8m)
Construction lengths	196 mm ... 1996 mm (depending on design) refer to table in chapter 3.4 (optional bis zu 3096 mm)
Strahlabstand	7,5 mm , 14 mm, 100 mm, 200 mm, 300 mm, 400 mm, 500 mm(depending on design) refer to table chapter 3.4
Resolution	14 mm , 30 mm (depending on design and beam spacing) refer to table in chapter 3.4, (higher beam spacing change resolution)
Number of beams	2... 247 beams (depending on number of beams) refer to table in chapter 3.4

Table 11/1

Mechanical data

Housing design	Aluminium profile, plastic-coated RAL 1020, yellow, end pieces made from non-corrosive, spherically reinforced plastic (polyamide). Plexiglass light outlet and inlet, optional with solvent-resistant silicate glass.
Attachment	Shifting fastening brackets on rear side of housing
Weight	Transmitter: 0.45 kg to 4.5 kg depending on construction length Receiver: 0.5 kg to 5.0 kg depending on construction length

Table 11/2

Operating data

Protection category	IP 65
Protection class	III
Operating ambient temperature	-10 bis 55 °C
Storage temperature	-25 bis 70 °C

Table 11/3

Electric Data

	Transmitter ULVTS / BLVTS	Receiver ULVTE / BLVTE
Power supply	24 V DC, + 20 % - 10 %, SELV	24 V DC, ±20%, SELV
Current draw	max. 250 mA	max. 250 mA (no load)
Outputs	-	OSSD 1 and 2: Failsafe PNP outputs, max. 0.5 A, short-circuit and cross-circuit monitoring (in operating mode with antivalent outputs, output 2 is not failsafe, max. 20 mA)
Inputs	-	Contacteur check and start button inputs: 0 V to 24 VDC + 20% / 10 mA
Electric connection	Integrated connector plug with PG9 as strain relief, alternatively conventional connector plug	Integrated connector plug with PG9 as strain relief, alternatively conventional connector plug
Connecting cable	3-pol. max. 0,75 mm ²	5 to 7-pin (depending on operating mode), max. 0,5 mm ²
Connecting cable (UL)	Use UL-certified 60/75°C copper conductors	Use UL-certified 60/75°C copper conductors

Table 11/4

3.8 Dimensional drawings transmitter / receiver ULVT/ BLVT

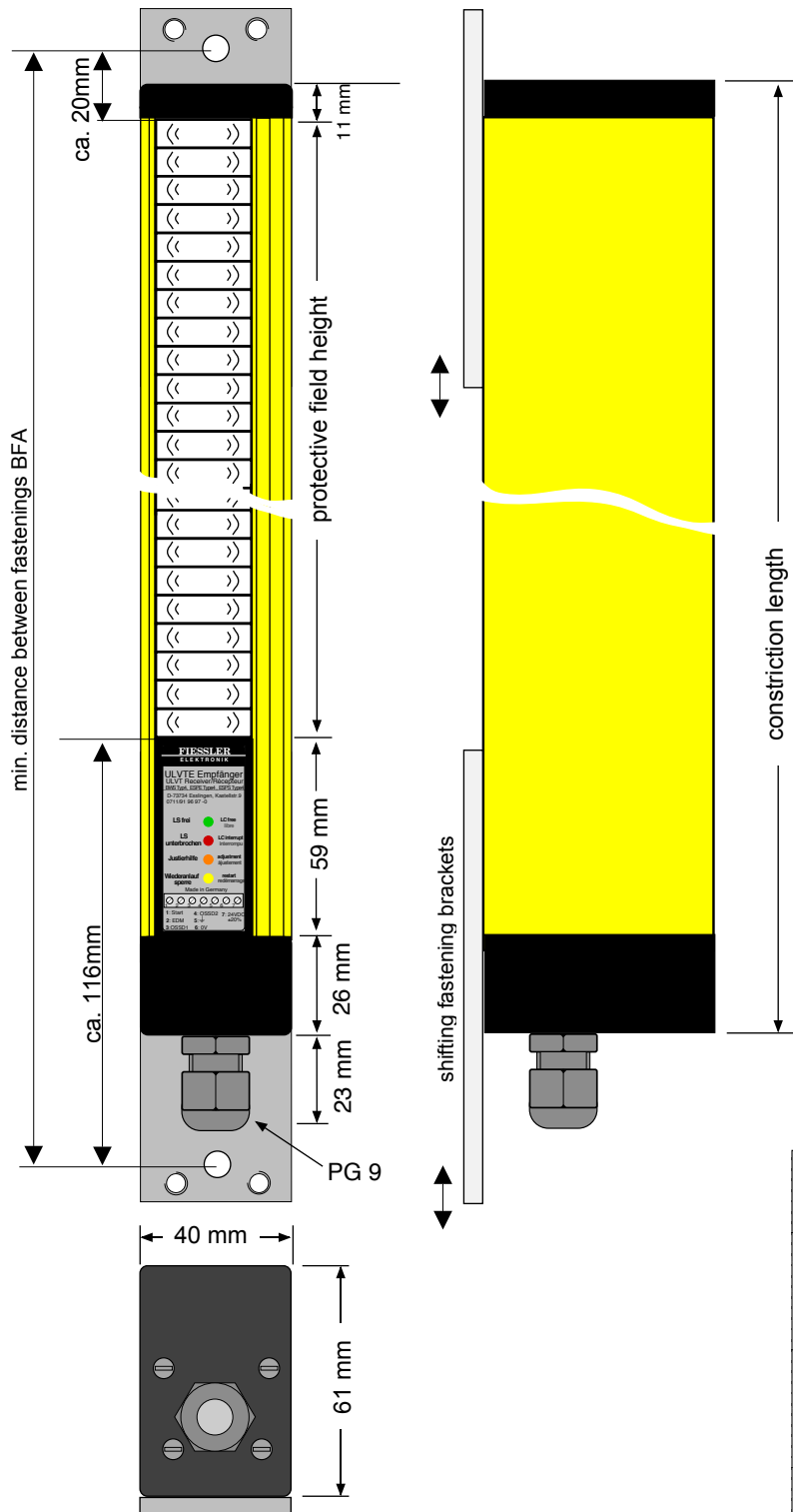

fig. 12/1 dimensions transmitter/receiver

Housing design:

Aluminium profile, plastic-coated RAL 1020, yellow, end pieces made from non-corrosive, spherically reinforced plastic (polyamide). Plexiglass light outlet and inlet, optional with solvent-resistant silicate glass.

Attachment:

Shifting fastening brackets on rear side of housing

Standard fastening brackets

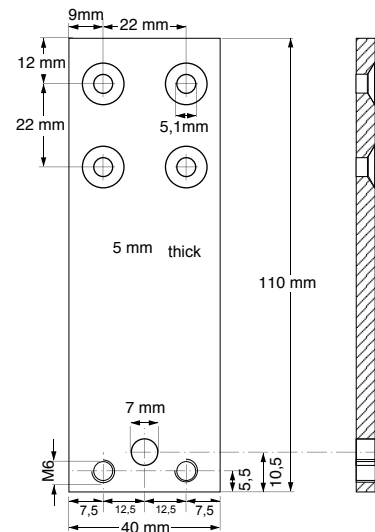

fig. 12/2 Fastening brackets

protective field height (mm)	constr. length (mm)	min. distance between fastenings BFA (mm)
100	196	236
200	296	336
300	396	436
400	496	536
500	596	636
600	696	736
700	796	836
800	896	936
900	996	1036
1000	1096	1136
1100	1196	1236
1200	1296	1336
1300	1396	1436
1400	1496	1536
1500	1596	1636
1600	1696	1736
1700	1796	1836
1800	1896	1936
1900	1996	2036

Table 12/3

4.1 Response time (reaction time)

With ULVT/BLVT light curtains, the response time t_1 of the safety device depends on the number of beams.

The type name contains the construction height and the number of beams (please refer also to table on page 9).
(e.g.: ULVT 500/65 => construction length: 500 mm and 65 beams) .

ULVT (category 4) TLVT (category 2)			
no. of beams	response time (ms)	no. of beams	response time (ms)
2	4	56	9
3	4	63	10
4	4	65	10
5	4	70	10
6	5	77	11
7	5	78	11
8	5	84	12
9	5	91	12
10	5	98	13
11	5	104	13
12	5	105	13
13	6	112	14
14	6	117	14
15	6	119	15
16	6	126	15
17	6	130	15
18	6	133	16
19	6	143	17
20	6	156	18
21	6	169	19
26	7	182	20
28	7	195	21
35	7	208	22
39	8	221	23
42	8	234	24
47	9	247	25
52	9		

Table 13/1 number of beams and response times ULVT

BLVT (category 4 mit Ausblendfunktion) ILVT (category 2 mit Ausblendfunktion)			
no. of beams	response time (ms)	no. of beams	response time (ms)
2	6	56	13
3	6	63	14
4	6	65	14
5	6	70	14
6	6	77	15
7	6	78	15
8	7	84	16
9	7	91	17
10	7	98	18
11	7	104	19
12	7	105	19
13	7	112	20
14	7	117	20
15	8	119	21
16	8	126	21
17	8	130	22
18	8	133	22
19	8	143	24
20	8	156	25
21	8	169	27
26	9	182	28
28	9	195	30
35	10	208	32
39	10	221	33
42	11	234	35
47	11	247	37
52	12		

Table 13/2 number of beams and response times BLVT

cascaded light curtains ULVTK / BLVTK		
System / example	Response time (ms)	notes
Master sensor ULVTK 800/56 = 9 ms	own response time (see table above)	
slave sensor 1 ULVTK 500/35 = 7 ms + 3 ms = 10 ms	own response time (see table above)+ 3 ms	Response time of the slave sensor 1 increases for 3 ms compared to a standard system, due to the fact that the master sensor detects an interruption of the following sensor 1 within 3 ms.
slave sensor 2 ULVT 800/3 = 4 ms + 6 ms = 10 ms	own response time (see table above)+ 6 ms	Response time of the slave sensor 1 increases for 6 ms compared to a standard system, due to the fact that the slave sensor 1 detects an interruption of the slave sensor 2 within 3 ms, and that the master sensor detects an interruption of the slave sensor1 within 3 ms.

Table 13/3 Response time of cascaded systems

optionals safety switching units	
Typ	Response time(ms)
PLSG 1 (Muting switching unit)	3,5
PLSG 2 (Muting switching unit)	3,5
PLSG 3 (Switching unit for machine control)	3,5
ULSG	6
BPSG (BLVT-Programmer-controller)	6
LSUW N1 Muting K	20
LSUW NSR 3-1 K	25

Table 13/4 Response time safety switching units

4.2 Safe distance from hazardous areas



The safe distance (S) between the accident-preventing light barrier and hazardous area must be big enough to ensure that when the protective field is penetrated, the hazardous area cannot be accessed before the hazardous movement has been ended.

In addition, it must be ensured that reaching over, under or around, or walking behind the protective field is prevented by additional mechanical screening or further light barriers. To this end, please also refer to EN 999 / ISO 13855 and other effective national and international safety regulations.

4.2.1 Vertical light barrier protection of hazardous areas

(valid for up to 40 mm resolution)

The safe distance S is calculated as follows:

$$S = (K \times T) + C$$

- **K = Grabbing speed or approach speed**

For the grabbing speed K, a speed of 2000 mm/s is preset. If the calculation for S produces a value greater than 500 mm, the calculation can be repeated with 1600mm/s if this does not lead to a value lower than 500 mm (S min > 100 mm)

- **T = t1 + t2**

t1 = Response time of the safety device

With ULVT light barriers, the response time of the safety device t1 depends on the number of beams (refer to Table on page 13).

When using the ULVT with the optional safety switching units, the response time of the switchgears is added to t1:

For LSUW N1 Muting switchgear:	20 ms
For LSUW NSR 3-1K switchgear:	25 ms
For ULSG switchgear:	6 ms

- **t2 = overrun period of the machine**

The overrun period of the machine t2 must be specified by the machine manufacturer.

- **C = 8 (d - 14 mm)**

d = Definition of the safety device (minimum detectable obstacle size)

The definition capacity d (= 14 mm or 30mm) is specified on the nameplate of the ULVT light barrier,

for d = 14mm => C=0,
for d= 30 0> C= 128mm

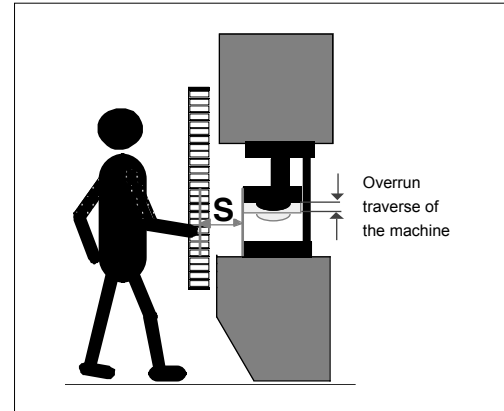

fig. 14/1 Vertical light barrier protection of hazardous areas

Calculation examples for the safe distance with vertical area protection using ULVT light barriers

(valid for up to 40 mm resolution)

for S = 100 mm bis 500 mm:

$$S = (2000 \text{ mm / s} \cdot T) + C$$

for S > 500 mm:

$$S = (1600 \text{ mm / s} \cdot T) + C$$

Example 1:

Safety light curtain ULVT100/13, resolution d = 14mm,
overrun period t2 of the machine from 75 ms

$$S = 2000 \text{ mm/s} \times (0.075\text{s} + 0.006\text{s})$$

$$S = \underline{162 \text{ mm}}$$

Example 2:

Safety light curtain ULVT500/35, resolution D = 30mm, ULSG safety switchgear
Overrun period t2 of the machine from 75 ms

$$S = 2000 \text{ mm/s} \times (0.075\text{s} + 0.007\text{s} + 0.006\text{s}) + 8 \times (30\text{mm}-14\text{mm})$$

$$S = \underline{304 \text{ mm}}$$

4.2.2 Horizontal protection of hazardous areas by light grids (EN 999 / ISO 13855)

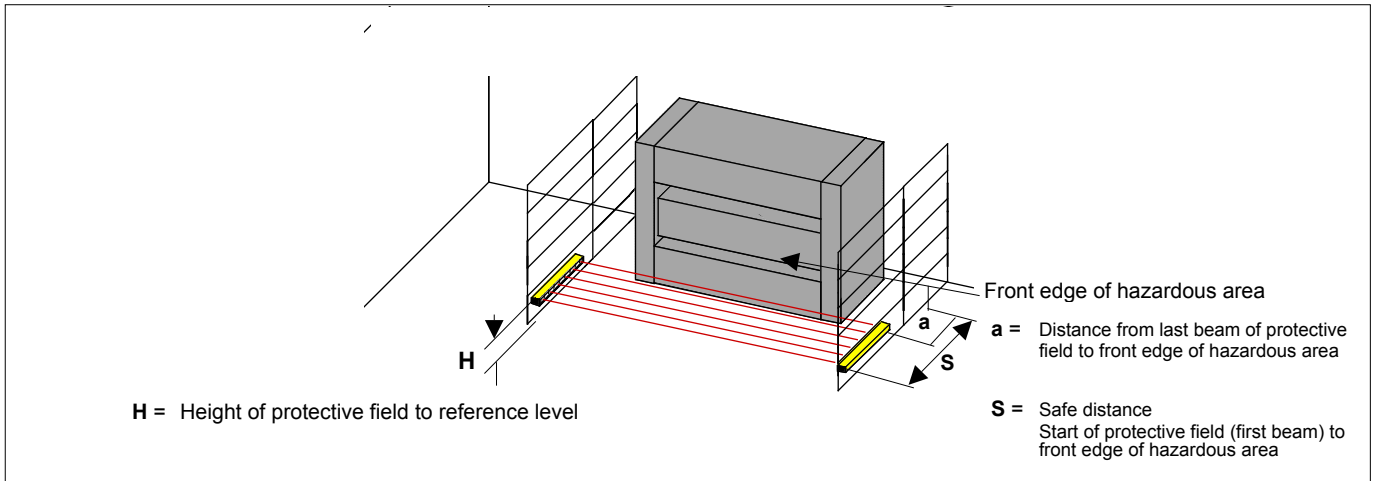

fig 15/1 Horizontal protection

Formula for calculating the safe distance with horizontal protection of hazardous areas using a light curtain:

$$S = (K \times T) + C$$

Here:

$$K = 1600 \text{ mm/s}$$

C = 1200mm-0.4H, but smaller than 850 mm, whereby H is the height in mm of the protective field above the reference level, e.g. floor.

$$T = t1 + t2 \text{ (refer also to page 14)}$$

t1 = response time of the barrier

t2 = Overrun period of the machine

$$S = (1600 \text{ mm} / s \times T) + (1200 \text{ mm} - 0,4 H)$$

With a height H of the protective field above the floor of > 300 mm, a risk of crawling under exists. This must be considered in risk assessment.

The following condition thus applies for H ≥ 300 mm:

$$1200 - 0.4 \times H > 850 \text{ mm}$$

The distance a of the end of the protective field (last beam to front edge of hazardous area) must be no more than:

$$a = H / 15 + 40 \text{ mm}$$

example:
Height 200 mm

$$a_{\text{max}} = 200 / 15 + 40 \text{ mm}$$

$$a_{\text{max}} = 53 \text{ mm}$$

Calculation examples for the safe distance with horizontal protection of hazardous areas using **ULVT** light barrier:

Example:

ULVT1200/156 light barrier

Response time t1 of light barrier: 18 ms

Run-on time t2 of machine: **50 ms**

H = 200 mm

The safe distance is:

$$S = (1600 \text{ mm} / s \times (0.050 \text{ s} + 0.018)) + (1200 \text{ mm} - 0.4 \times 200 \text{ mm})$$

$$S = 1229 \text{ mm}$$

With the ULVT 1200/156, the protective field depth is 1200 mm.

A distance a between the last beam of the protective field and the front edge of the hazardous area must then be 29mm + 7,5mm = 38,5mm

(the last beam must be added).

4.2.3 Vertical protection of hazardous areas by 2-, 3-, 4- beam light grids (EN 999 / ISO 13855)
(valid for more than 40 mm resolution)

Formula for calculating the safe distance with vertical protection of hazardous areas using 2-, 3-, 4-beam light grids:

$$S = (1600 \text{ mm} / \text{s} \cdot T) + 850 \text{ mm}$$

example:
overrun period of the machine : 75 ms

The safe distance for a light grid ULVT... with 2 beams

$$S = (1600 \text{ mm} / \text{s} : 0,075 \text{ s}) + 850 \text{ mm}$$

$$S = 976 \text{ mm}$$

Positioning of the beams

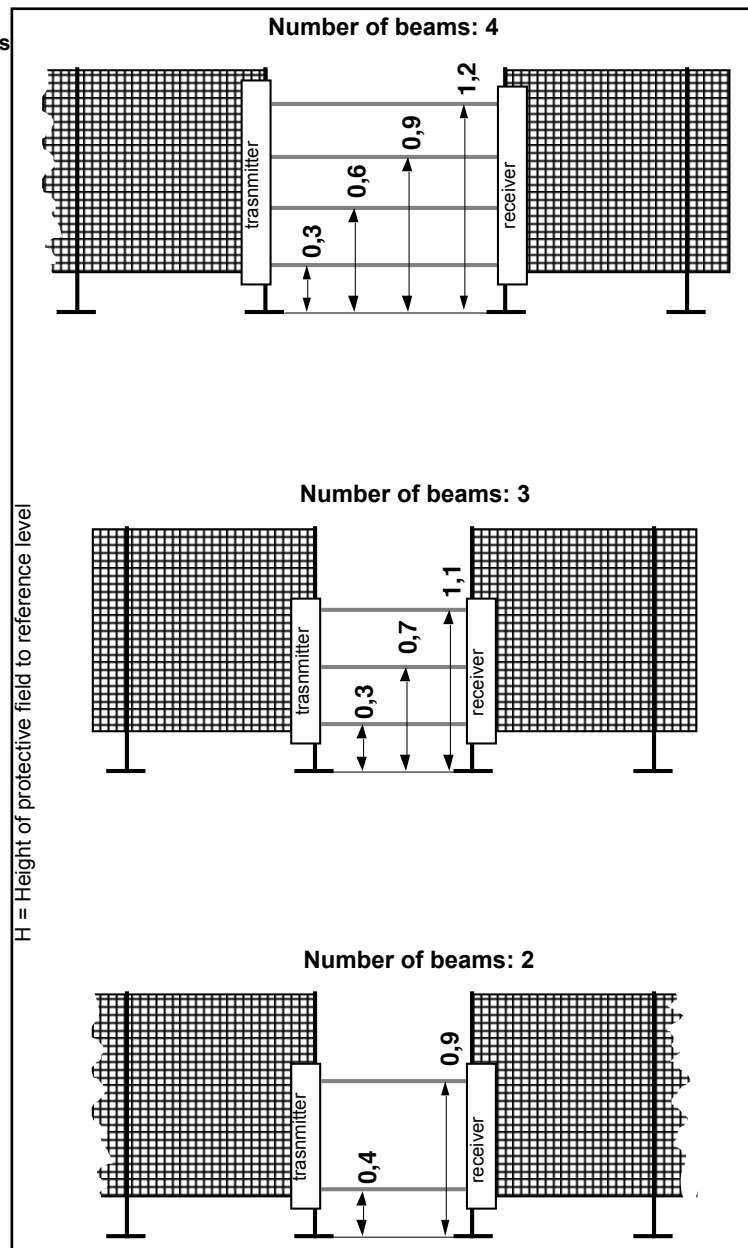

fig 16/1 Vertical protection

4.3.1 Installation without additional screening

The light transmitter (a) (Fig. 17/1) and the light receiver (b) form the light barrier (c). If the light beams are interrupted, e.g. by a hand, a pilot circuit is opened and the closing action is prevented / stopped. In the opposite example, it is not possible to avoid the ULVT light barrier from the working side, which means that additional screening is not required.

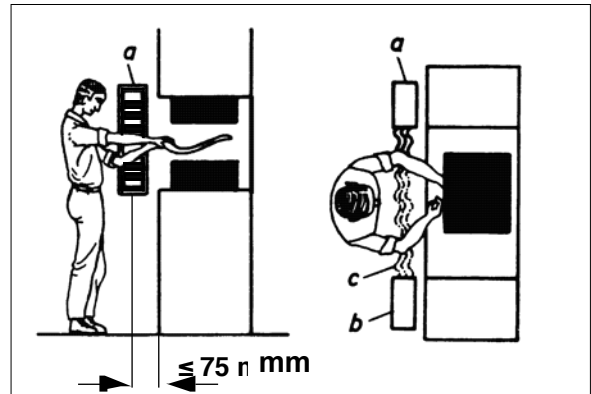

fig. 17/1 Installation without additional screening



In order to prevent the walking behind the protective field, the distance between the ULVT/BLVT safety light barrier and the machine must be ≤ 75 mm.

4.3.2 Protection against reaching under and over



In a normal working process (Fig. 17/2a), the operator inserts the workpiece when sitting down. Due to the over-run period of the machine, the ULVT/BLVT safety light barrier (a) is mounted slightly in front of the hazardous area (refer to chapter 4.2). However, the light barrier height selected here leaves an unprotected gap at the top of the light barrier. Fig. 17/2b shows how reaching over the light barrier can lead to an accident. The proper rectification of this problem is illustrated in Fig. 17/2c, where a ULVT safety light barrier with a larger protective field height has been attached.

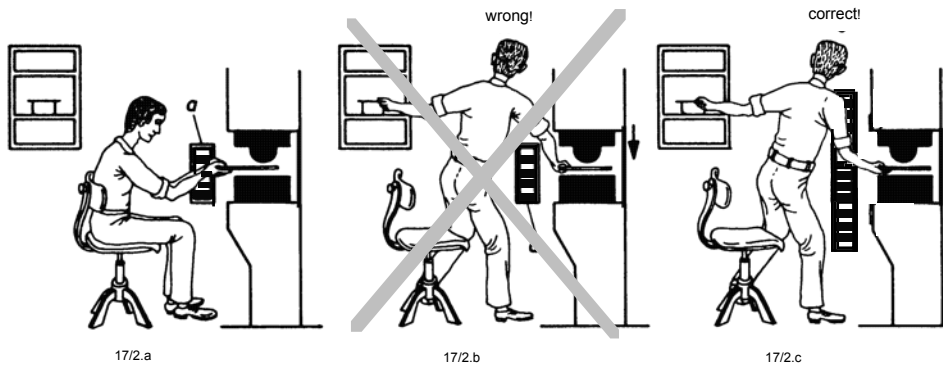

fig 17/2a,b,c Protection against reaching under and over

4.3.3 Protection against walking behind through cascading or additional screening



If the distance between the vertical ULVT/BLVT safety light barrier and the machine needs to be greater than 75 mm (e.g. in order to maintain the safe distance to the hazardous area), the possibility of walking behind the protective field must be eliminated through an additional ULVT safety light barrier and/or cascading of two light barriers (Fig. 17/3 and 17/4) or a protective bar.

In cascading, varying form factors can be combined (e.g. main sensor with 1100 mm protective field height and succeeding sensor with 200 mm protective field).

Please refer to chapter 8.

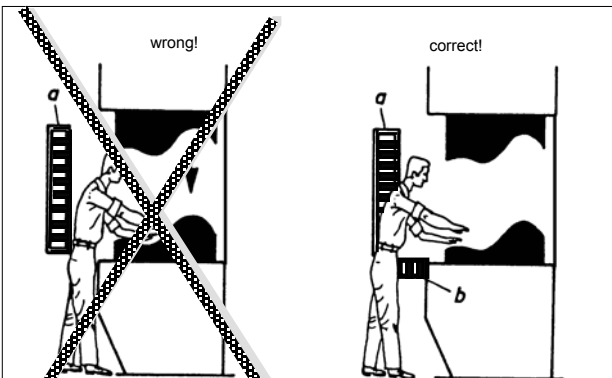

fig 17/3 Protection against walking behind through cascading of two light barriers

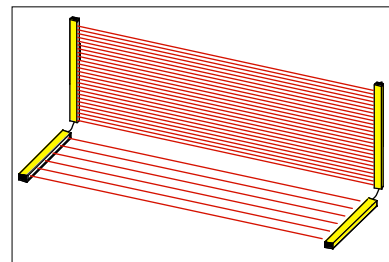



fig 17/4 Cascading of two safety light curtains

4.3.4 Distance from reflective surfaces

 To prevent the avoidance and non-detection of an obstacle due to reflecting objects, the ULVT/BLVT safety light barrier must be assembled with a minimum distance **a** (Fig. 18/1) from the reflective object.

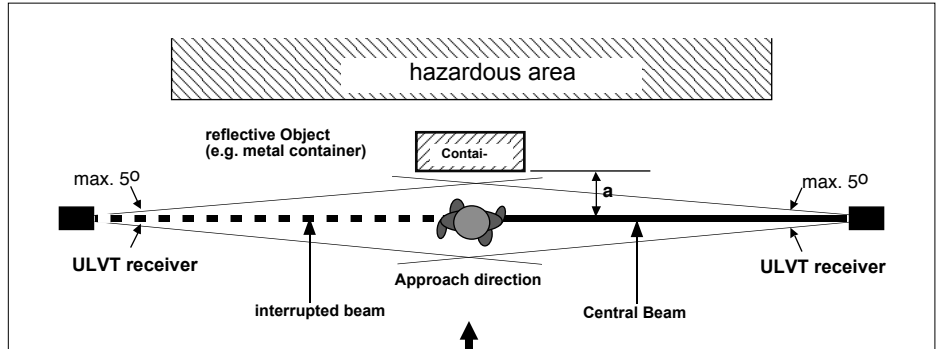



fig 18/1 distance from reflective surfaces

The minimum distance **a** can be established from the table:

installation range in m	up to 3	4	5	6	7
distance a in mm	130	175	219	262	306

Table 18/2 installation ranges and distances

4.3.5 Arrangement of two adjacent safety light barriers ULVT/ BLVT...

 To eliminate the mutual clashing of two adjacent ULVT/BLVT... safety light barriers, the following must be observed when arranging two light barriers:

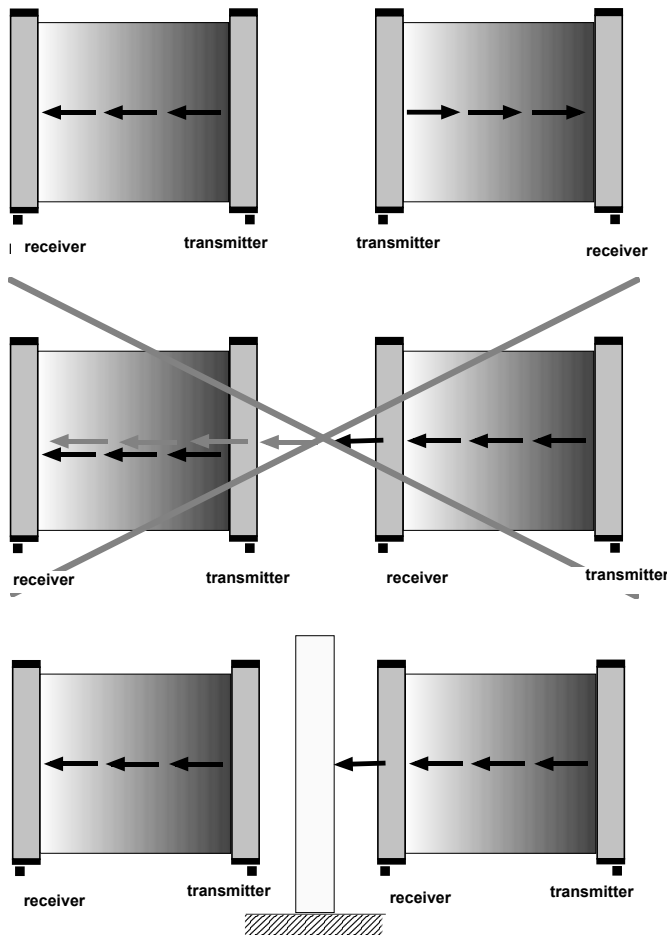

fig. 18/3 Arrangement of 2 adjacent light curtains

4.4 Attachment and adjustment of transmitter and receiver

When installing the transmitter and receiver, it must be ensured that connectors of both devices are located on the same side. The receiver and transmitter must be installed with **parallel faces**.

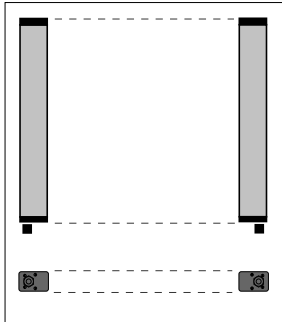

fig19/1 Installation with parallel faces

Important:



In order to ensure an error-free operation, both the light transmitter and light receiver must be attached to stable, distortion-free and face-parallel constructions. Install the fastening brackets so that the adjusting screws remain easily accessible. Make sure that the housing is not distorted. Otherwise a perfect visual adjustment will not be possible. Adjust one fastening bracket whilst the adjusting screws on the other fastening bracket are loose.

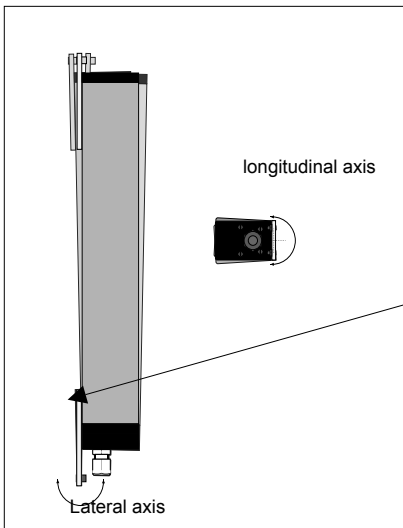
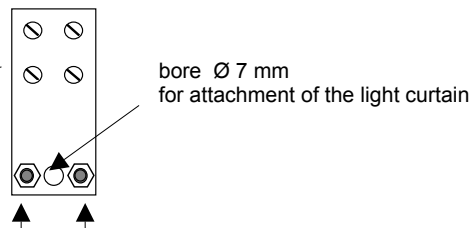

Fig 19/2 Swivelling around longitudinal and lateral axis

The supplied fastening brackets serve for the attachment and the adjustment of the light barrier. Together with the shifting tenon blocks, the brackets enable a universal attachment.

To swivel the longitudinal axis, turn the respective adjusting screw on one of the fastening brackets whilst both screws on the other fastening bracket are loose. To swivel the lateral axis, turn both screws of a fastening bracket at the same time whilst both screws on the other fastening bracket are loose.



Adjusting screws with counter nuts for swivelling along longitudinal and lateral axes. **Further adjustment information is provided in chapter 6.2, "Commissioning".**

Assembled standard mounting brackets at the light curtain

Dimension drawing of these standard brackets see page 12 chapter 3.8

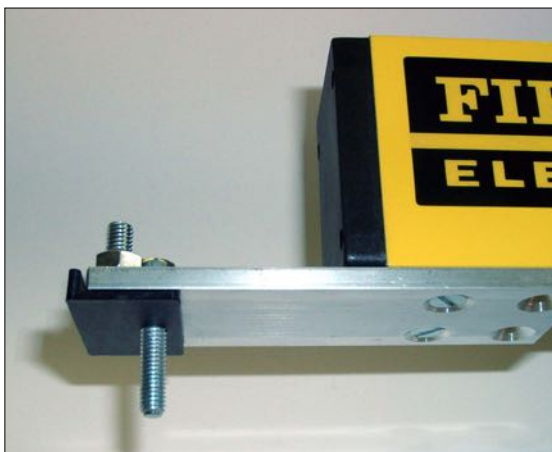

fig 19/3 standard mounting brackets mounted at the light curtain.

Insulating brackets at the receiver unit

These can improve insensitivity to interference clearly during EMV contaminated environment.

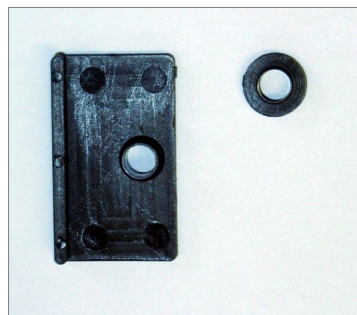

fig 19/4 insulating plastic layers

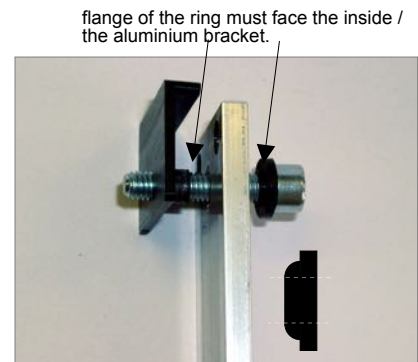

fig 19/5 mounted brackets with insulating plastic layers

4.4.2 Option! Angular Brackets

Angular shaped mounting brackets for attaching the light curtain to already existing holders, or if there is not enough space for the installation at the back

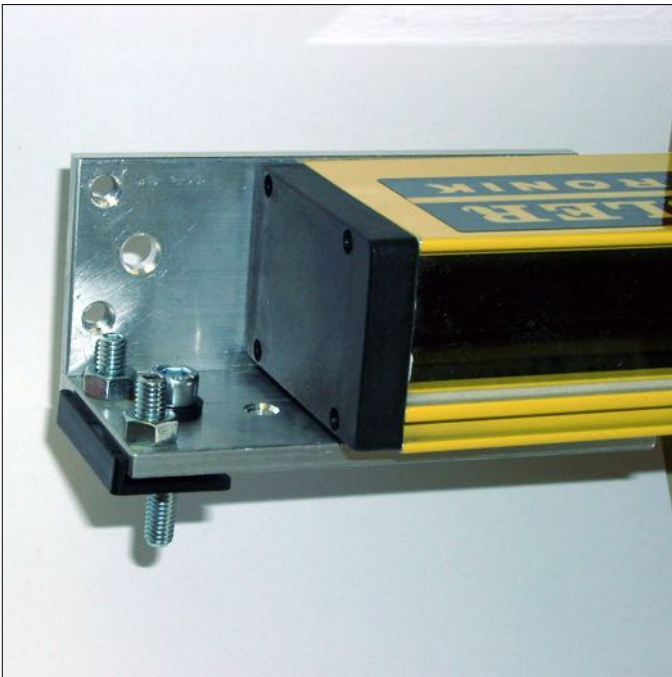

fig 20/1 angular mounting brackets mounted at the light curtain.



fig 20/2 angular brackets

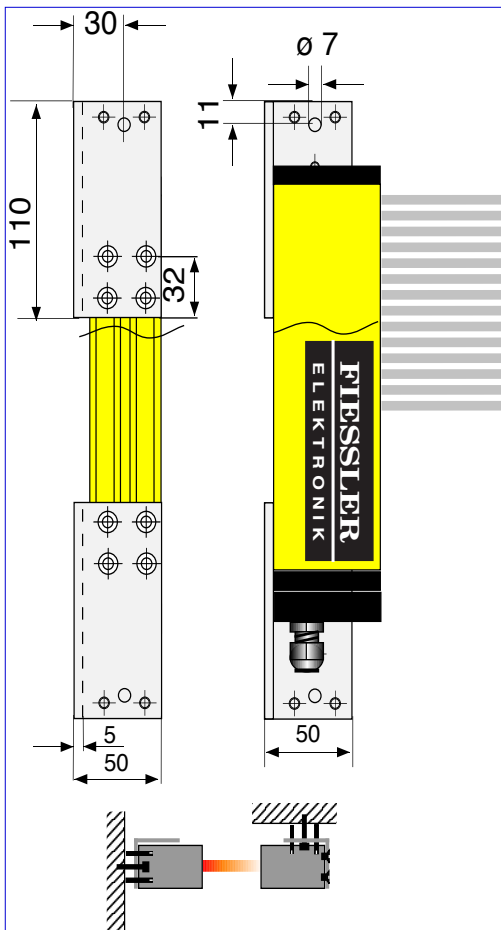
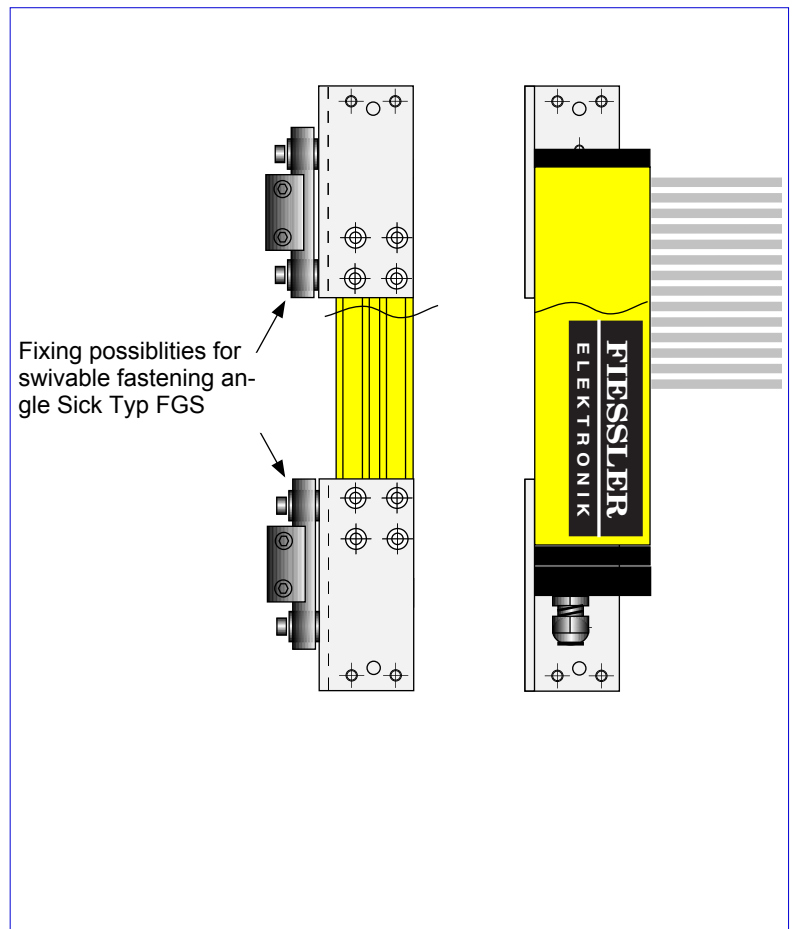

fig 20/3



Fixing possibilities for swivable fastening angle Sick Typ FGS

fig 20/4 angular brackets

4.4.3 Option: Anti-vibration brackets

For installation of the light curtain at vibrating machines



fig 21/1 Anti-vibration brackets

4.4.4 Multi-sided screening through tilted mirrors

Using tilted mirrors, the protective field can be "wrapped around" a hazardous area, thus providing protection from several sides (Fig. 21/1 and Fig. 21/2). Here, the law of reflection applies, whereby the angle of incidence is the same as the angle of reflection. This means for that tilting of 90° requires the mirror to be installed at an angle of 45°. For this purpose, the tilted mirrors for ULVT feature swivelling attachments.

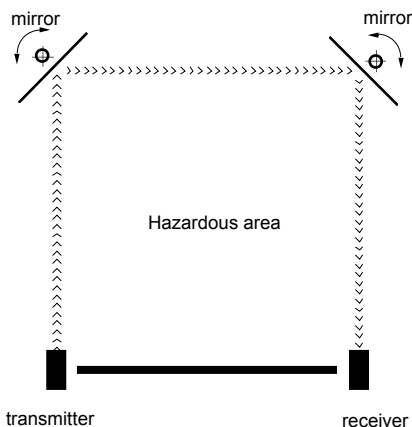

fig 21/2 Arrangement of 2 tilted mirrors

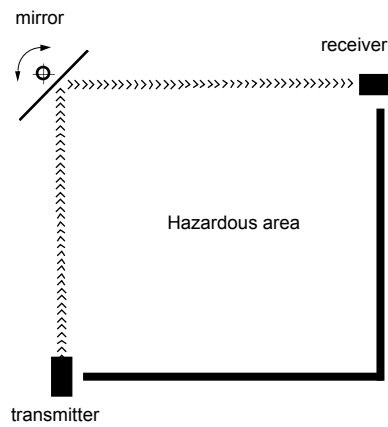

fig 21/3 Arrangement of 3 tilted mirrors

Reflection loss: Each reflection via a mirror weakens the transmitted signal. For this reason, the max. range and number of mirror reflections must be observed when using mirrors. The transmitter, receiver and mirrors must always be assembled vertically and checked using a spirit level. uren.



Operational reliability can only be ensured when the mirrors are assembled in a stable manner.

Refer to chapter 6.2 for precise adjusting information.

Housing design:

Distortion-free aluminium dual-chamber profile, plastic-coated RAL 1021, yellow

Attachment:

Spherical head screw. The mirror can be attached to a holder by using the spherical head screw.

Further installation options are provided by the threaded bores on the mirror profile.

Option ---> threaded screws for hanging or free-standing installation



Dimensions drawing :

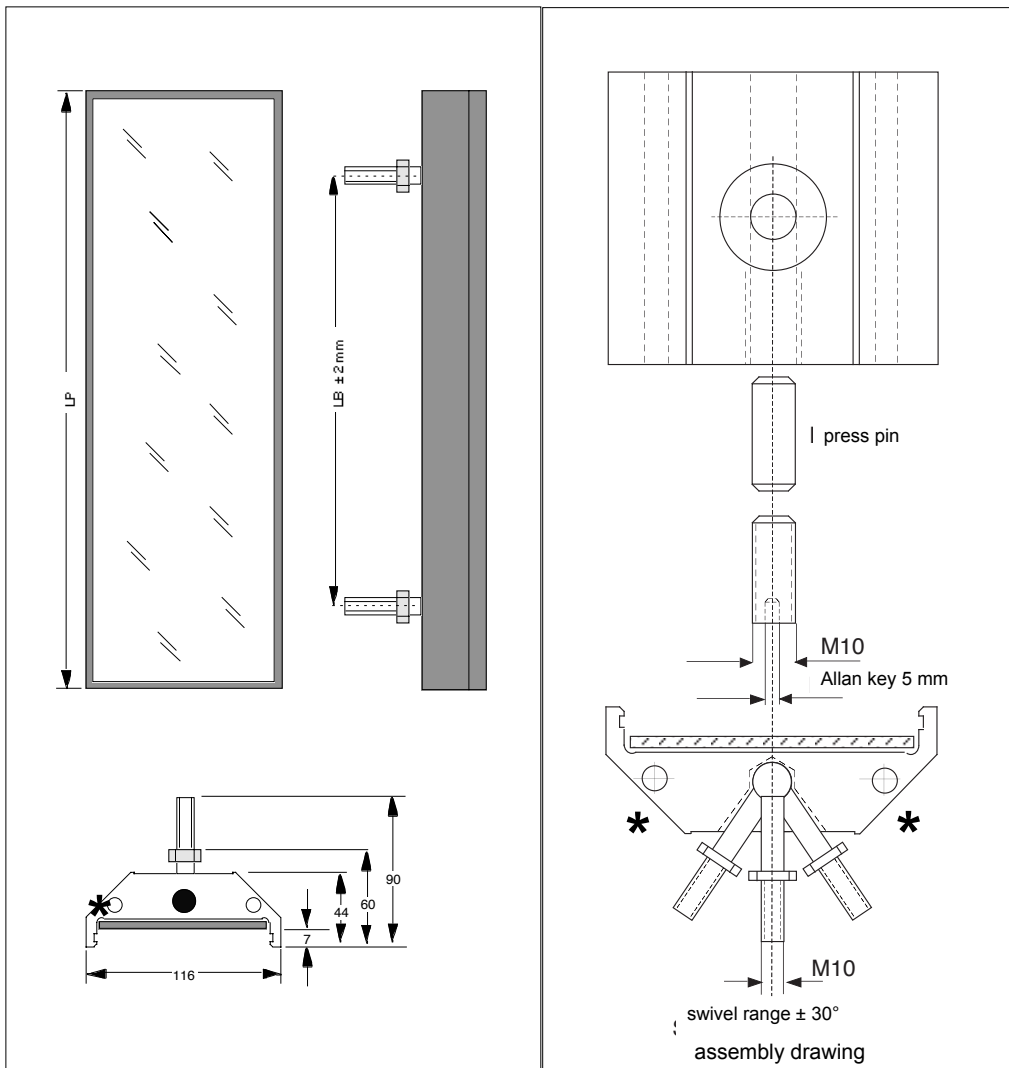

fig. 22/1

Form Factors:

for protective field height	profile length LP	attachment distance LB	weight g	order code
100	200	mittig	1667	usp100
200	300	195	2297	usp200
300	400	295	2927	usp300
400	500	395	3557	usp400
500	600	495	4187	usp500
600	700	595	4817	usp600
700	800	695	5447	usp700
800	900	795	6077	usp800
900	1000	895	6707	usp900
1000	1100	995	7337	usp1000
1100	1200	1095	7967	usp1100
1200	1300	1195	8597	usp1200
1300	1400	1295	9227	usp1300
1400	1500	1395	9857	usp1400
1500	1600	1495	10487	usp1500
1600	1700	1595	11117	usp1600
1700	1800	1695	11747	usp1700
1800	1900	1795	12377	usp1800
1900	2000	1895	13007	usp1900

Table 22/2

Installation information:

1. Insert the spherical head screw into the pocket hole as shown in the drawing.
2. Insert the press pin.
3. Screw in the hexagon screw and tighten using a 5 mm Allan key.

4.4.5 4.5 Assembly columns

For installation in an open area (e.g. for the multi-sided protection of hazardous areas), the ULVT light barriers and titled mirrors can be supplied as premanufactured assembly columns.

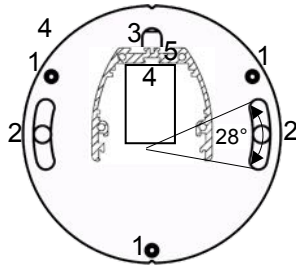

fig 23/1 Base plate

- 1: Three adjustment screws for adjusting the column
- 2: Two elongated mounting holes for fastening the baseplate on the floor and for fine adjustment of the column (max. M12 screws)
- 3: Cable duct
- 4: Groove for fastening the light barrier by using the brackets (brackets are included in delivery)
- 5: Fastening grooves for fastening the column (without base plate) on a machine or on the wall.

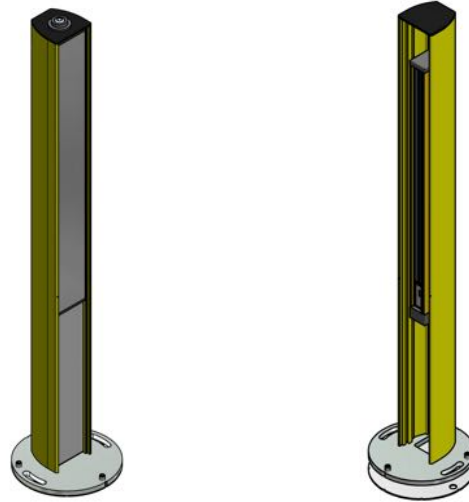

fig 23/2 assembly columns for light curtains and titled mirrors

order codes (examples)

assembly columns for transmitter and receiver including base plate	assembly columns with tilted mirrors inc. Bodenausgleichsplatte	assembly columns for transmitter and receiver no base plate, with 2 end pieces	assembly columns with tilted mirrors no base plate, with 2 end pieces
SAU 100	SASU 100	SDU 100	SDSU 100
SAU 200	SASU 200	SDU 200	SDSU 200
SAU 300	SASU 300	SDU 300	SDSU 300
...
SAU 1700	SASU 1700	SDU 1700	SDSU 1700
SAU 1800	SASU 1800	SDU 1800	SDSU 1800
SAU 1900	SASU 1900	SDU 1900	SDSU 1900
always in 100 mm steps	always in 100 mm steps	always in 100 mm steps	always in 100 mm steps

Table 23/3 order codes

for ULVT with 1700 mm protective field height

for ULVT with 300 mm protective field height

Caution: Shock-protector columns the same as assembly columns without base plate, but with 2 plastic covers at their ends.

Installation of the columns

1. Provide electric connection of transmitter and receiver
2. Optically align the transmitter, receiver and mirrors
3. Check for correct function
4. Drill the holes and attach the columns

The transmitter, receiver and mirror columns are attached vertically at the same height. A precise spirit level must be used to check this. With vertical arrangement, the 3 adjusting screws are used on the respective posts. The columns can be rotated using the elongated assembly slots.

Grooves in the base plate allow to turn the base plate in an angle of exactly 45° to each side.

This feature enables an easier adjustment of the mirror column as well as of the mounted light curtain / light grid.

Fine tuning is carried out as described in Section 6.2, "Commissioning".

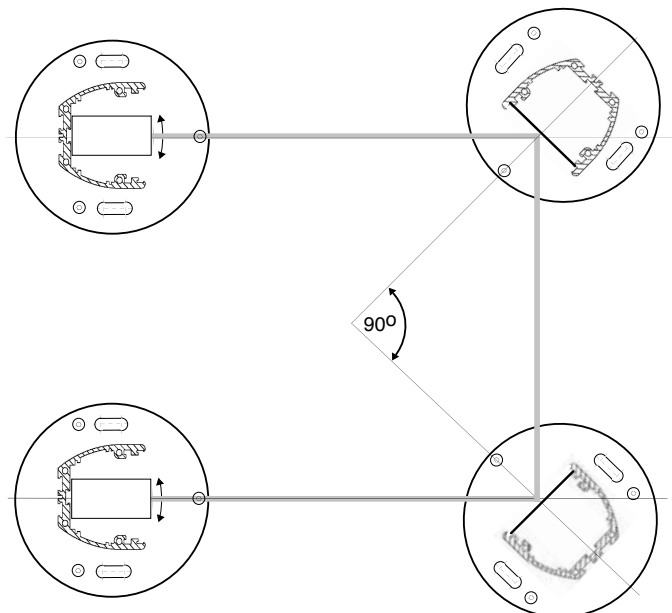

fig 23/4 Installation of the columns

4.4.5.1 dimension drawing : installation of one assembly-column with tilted mirror

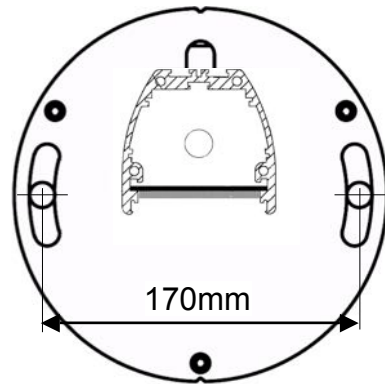

fig 24/1 column with tilted mirror

During installation of the floor plate , please observe that the distance between the drilled holes must be 170 mm.
The elongated mounting holes allow to turn the colum with its floor plate in an angle of 14° to each side.
The three adjustment screws allow a perpendicular adjustment of the column.

During adjustment of the column please observe that the central point of the column is exactly correspond to the central point of the light barrier and to the mirror.

Additional plexiglass front windows are available as option.

4.4.5.2 dimension drawing : installation of the assembly-column with ULVT/BLVT

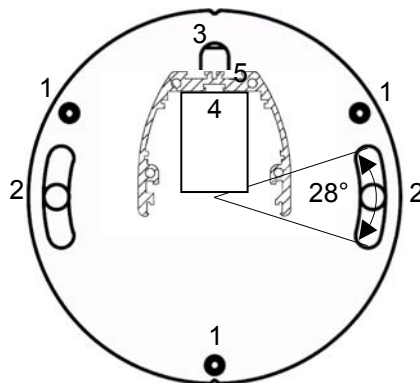

fig 24/2 column assembled wiuth light curtain ULVT/BLVT

- 1: Three adjustment screws for adjusting the column
- 2: Two elongated mounting holes for fastening the baseplate on the floor and for fine adjustment of the column (max. M12 screws)
- 3: Cable duct
- 4: Groove for fastening the light barrier by using the brackets (brackets are included in delivery)
- 5: Fastening grooves for fastening the column (without base plate) on a machine or on the wall.

Dimensions of ULVT/BLVT with e.g. 2, 3 or 4 beams (Height of the columns including base plate)

ULVT / BLVT 500/2	--->	960 mm	(first beam 400 mm above floor level according to EN 999 / ISO 13855)
ULVT / BLVT 800/3	--->	1160 mm	((first beam 300 mm above floor level according to EN 999 / ISO 13855)
ULVT / BLVT 1100/4	--->	1460 mm	(first beam 300 mm above floor level according to EN 999 / ISO 13855)
ULVT 500/2R	--->	1000 mm	((first beam 400 mm above floor level according to EN 999 / ISO 13855)

5.1 Integrated connector plug

The ULVT/BLVT construction series is supplied with PG threaded joints as standard. Various conventional connector plugs can also be obtained as optional accessories.



The electric connection must only be carried out when no voltage is present.

The electric connection is implemented via terminal screws in the connector cover (Fig. 25/1). The cover can be removed once the 4 screws have been loosened.

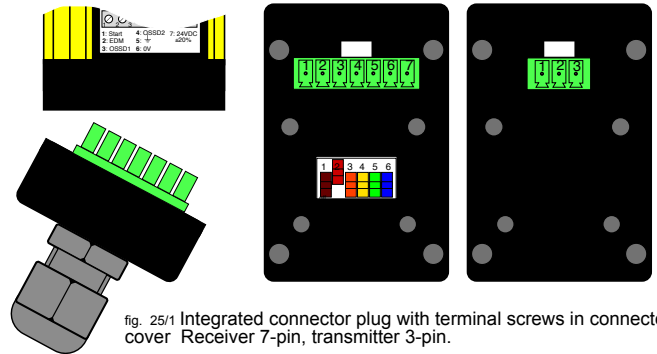

fig. 25/1 Integrated connector plug with terminal screws in connector cover Receiver 7-pin, transmitter 3-pin.

The transmitter and receiver require a power supply of 24 V DC. The ULSG switchgear performs the power failure bridging of 20 ms pursuant to EN 60204 and is thus suitable as the power supply for ULVT/BLVT light barriers. The receiver is equipped with 2 inputs and 2 outputs. The transmitter is connected via one 3-pin cable and the receiver via one 5 to 7-pin cable (depending on operating mode). The permissible cable cross-section is max. 1.5 mm². The cables must be routed separately from power lines.

5.2 Electric connection ratings

	ULVTS/BLVTS transmitter	ULVTE/BLVTE receiver
Power supply	24 V DC, + 20% - 10%, SELV	24 V DC, ±20%, SELV
Current draw	max. 250 mA	max. 250 mA (without load)
Outputs	-	OSSD 1 and 2: Failsafe PNP outputs, max. 0.5 A, short-circuit and cross-circuit monitoring (in operating mode with <i>antivalent outputs</i> , output 2 is a non-failsafe PNP output, max 20 mA)
Inputs	-	Inputs contactor check and start button: 0 V to 24 V DC, + 20%, 10 mA
Electric connection	Integrated connector plug with PG9 as strain relief, alternatively conventional connector plug.	Integrated connector plug with PG9 as strain relief, alternatively conventional connector plug.
Connecting cable	3-pin max. 1.5 mm ²	5 to 7-pin (depending on operating mode) max. 1.5 mm ²

Table 25/2 electric connection ratings

5.3 Connectors

- Outputs 1 and 2 (OSSD 1 and OSSD 2)

The outputs are not potential-free and must not be switched in series or parallel, but must be connected and processed separately!

In the **operating mode with equivalent outputs**, both PNP outputs are failsafe and feature internal short-circuit and cross-circuit monitoring. Both outputs are high (+24 V) when the light path is free.

In the **operating mode with antivalent outputs**, output 1 is high (+24 V) and output 2 low (0 V) when the light path is free. **Output 2 is not failsafe in this operating mode. This operating mode is only permissible in conjunction with the safety switchgears LSUW NSR 3-1K, LSUW N1-Muting K, or another safe sequential phase control device which monitors output 2!**

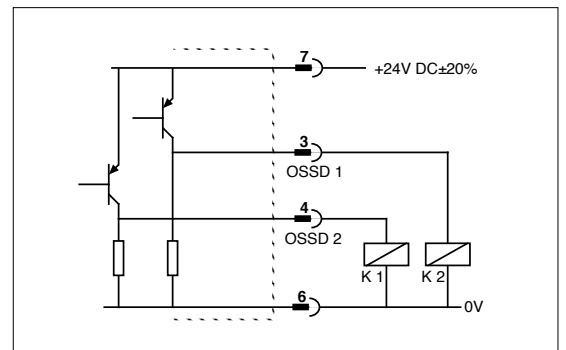

fig 25/3 outputs 1 and 2

- Input contactor check (EDM)

If the **operating mode with contactor check** is set, the auxiliary contacts K1 and K2 of the driven contactors K1 and K2 must be connected to the contactor check input in series and with +24 V as shown in Fig. 25/4.

The OSSD1 and OSSD 2 of the ULVT will only switch on the two contactors when contactor check input has detected the idle status of the contactors (+24 V at contactor check input).

Once the contactors have been driven, both of them must respond within 300 ms. The two auxiliary contacts must then be open (0 V at contactor check input).

If the **operating mode without contactor check** is set, the input contactor check must be unoccupied.

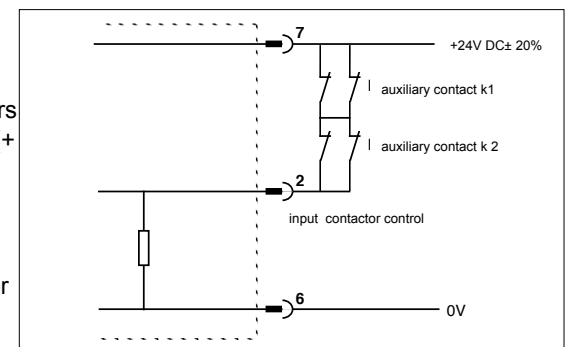

fig 25/4 input contactor control

- Input start button

If the operating mode with **restart interlock** is set, a button must be connected on the start button input for the start release of the operating movement (Fig. 26/1).

With a free protective field, the yellow LED on the receiver lights up as a start prompt. Only once the start button has been pressed will the two outputs OSSD1 and 2 of the ULVTE receiver be switched to active.

If the operating mode **without restart interlock** is set, the start button input (start) must be unoccupied).

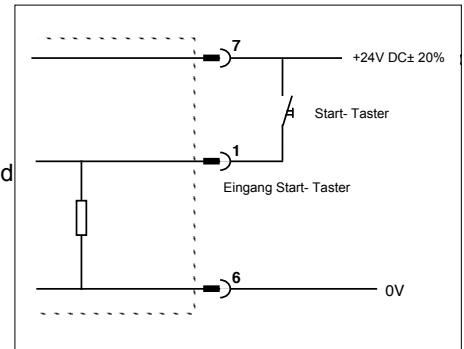

fig. 26/1 input start button

5.4 Connection examples (without the additional function such as Muting or cycle mode, please refer to the operation manual of the respective switching unit)

5.4.1 There is no need of a connection of the light transmitter at the light grid ULVT 500/2R, because the transmitter is integrated in the receiver unit.

Caution! Error-free operation can only be ensured when the safety light barrier is connected according to one of the following connection diagrams and also complies with effective national and international accident prevention regulations! Any deviation from these connection specifications can lead to hazardous conditions and is therefore not permitted.

5.4.2 Operating mode with restart interlock / contactor control

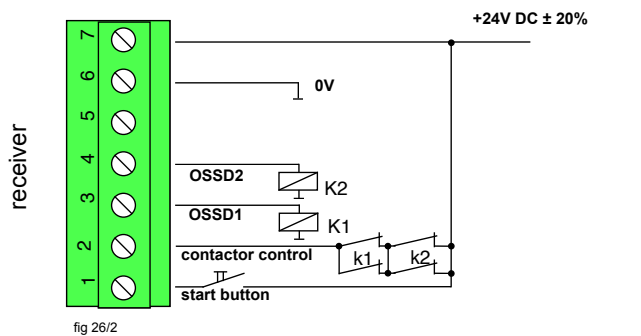

fig 26/2

5.4.3 Operating mode without restart interlock / contactor control

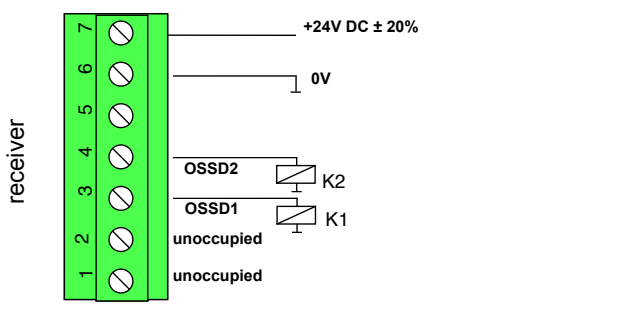

fig 26/3

5.4.4 PLC drive

When connecting to a safe stored program control (PLC) the outputs of the ULVT/BLVT must be connected to separate inputs of the PLC

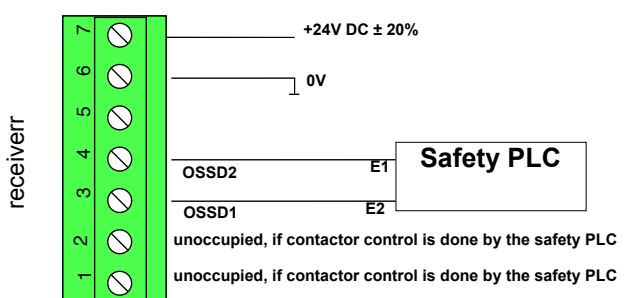

fig 26/4

6.1 Commissioning

Prior to commissioning, the appropriate operating mode for the respective application case must be set via the DIP switches in the terminal strip compartment (refer to Section 3.6). When delivered, the operating mode **with restart interlock, contactor check and equivalent outputs** is pre-set. The electrical connection must be made according to the selected operating mode. (refer to chapter 5).

6.1 Adjustment information

The visual alignment is advantageously carried out with intensely dimmed ambient lighting in order to be able to better detect the LED indications of the receiver even from a long range.

When aligning, it must be ensured that the housings do not become distorted.

An **adjustment laser** can be obtained for the precise alignment of the ULVT/BLVT light barriers, particularly where large distances are involved. The device is attached to the front panel of the transmitter and receiver. When the button is pressed, the laser produces a red light spot which can also be seen from long distances. The light spot must hit the centre of the opposite device. This test should be performed at both ends of the transmitter and receiver. The arrangement must be adjusted if necessary.

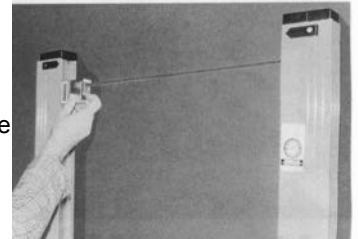

fig 27/1 adjuster laser

Adjustment with operation via tilted mirrors: Place the adjustment laser onto the front panel of the transmitter, switch it on and swivel the transmitter until the light spot hits the centre of the mirror. Then adjust the mirror so that the light spot also hits the centre of the second mirror / receiver.

Adjustment LED: The orange LED extinguishes when sufficient light reserve is present.

Fine tuning

Subsequent to the face-parallel installation and/or to the alignment using the adjustment laser, fine tuning is carried out by means of the adjusting screws on the supplied fastening brackets, provided that the orange LED is lit.

To swivel along the longitudinal axis, the respective adjusting screw on one of the fastening brackets is turned whilst both screws on the other fastening bracket are loose. To swivel the lateral axis, both screws of one fastening bracket are turned at the same time whilst both screws on the other fastening bracket are loose.

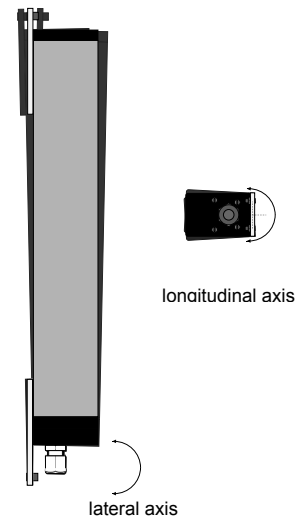

Subsequently, the green or yellow LED on the receiver should light up, and the orange LED must have extinguished.

LED	without restart interlock	LED	with restart interlock
green LED ON	<ul style="list-style-type: none"> LS frei LS unterbrochen Justierhilfe Wiederanlauf sperre <p>LC free libre </p> <p>LC interrupt interrompu </p> <p>adjustment Aide d'ajustement </p> <p>restart interlock interdiction de redémarrage </p> <p>Outputs active, light barrier free and correctly adjusted</p>	green LED ON	<ul style="list-style-type: none"> LS frei LS unterbrochen Justierhilfe Wiederanlauf sperre <p>LC free libre </p> <p>LC interrupt interrompu </p> <p>adjustment Aide d'ajustement </p> <p>restart interlock interdiction de redémarrage </p> <p>Outputs not active, (Prompt for start release with start button) light barrier free and correctly adjusted</p>
orange LED ON	<ul style="list-style-type: none"> LS frei LS unterbrochen Justierhilfe Wiederanlauf sperre <p>LC free libre </p> <p>LC interrupt interrompu </p> <p>adjustment Aide d'ajustement </p> <p>restart interlock interdiction de redémarrage </p> <p>Outputs active, light barrier free, but insufficient reserve To swivel along longitudinal or lateral axis until orange LED extinguishes</p>	orange LED ON	<ul style="list-style-type: none"> LS frei LS unterbrochen Justierhilfe Wiederanlauf sperre <p>LC free libre </p> <p>LC interrupt interrompu </p> <p>adjustment Aide d'ajustement </p> <p>restart interlock interdiction de redémarrage </p> <p>Outputs not active, (Prompt for start release with start button) light barrier free, but insufficient reserve or max. range exceeded Readjust and / or clean system and check range</p>

Table 27/3 Operating modes

Enlarged LED
 small LED

--> Lights up
--> Does not light up

--> ON
--> OFF



Test rod: Using the test rod, the light barrier is to be interrupted on the transmitting side from start to finish in such a way that the light field is only covered by this part. The green LED must not light up from start to finish. The diameter of the test rod must correspond to the obstacle size specified on the nameplate of the receiving side.

6.3 trouble shooting The prerequisite for the troubleshooting process is a correctly adjusted light barrier. (see chapter 6.2)



--> **LED lights up**

--> **LED does not light up**

Transmitter		
LED-display	possible causes	remedy
Yellow LED OFF <small>Sender ein</small> <small>Transmitter on</small>	no power supply	check power supply
Yellow LED flashing quickly (ca 4 x /s) <small>Sender ein</small> <small>Transmitter on</small>	a) internal fault. Transmitter inactive	switch off power supply and then switch on again. If yellow LED still flashes: Transmitter is defective and must be replaced.
Fehlerzustand!	b) voltage surge at the transmitter	reduce voltage
Yellow LED flashing slowly (ca 1 x /s) <small>Sender ein</small> <small>Transmitter on</small>	no fault! following light curtain is interrupted.	please refer to chapter 8.10 on page 39
only with cascaded transmitter		

Tabelle 28/1 Fehlersuche Sender

receiver		
LED-display	possible causes	remedy
no LED illuminated	no power supply	check power supply
Red LED on <small>LS frei</small> <small>LC free</small> Orange LED on <small>LS unterbrochen</small> <small>LC interrupt</small> <small>Justierhilfe</small> <small>Aide d'ajustement</small> <small>Wederanlauf sperre</small> <small>interdiction de redémarrage</small>	a) Transmitter inactive b) Light path interrupted c) Light barrier maladjusted or very dirt d) Max. range exceeded	a) Check transmitter b) Remove obstacle from light path c) Readjust and/or clean system d) Check range
Red LED on <small>LS frei</small> <small>LC free</small> Yellow LED on <small>LS unterbrochen</small> <small>LC interrupt</small> <small>Justierhilfe</small> <small>Aide d'ajustement</small> <small>Wederanlauf sperre</small> <small>interdiction de redémarrage</small>	No Prompt for start release with start button although the yellow LED lights: a) DIP switches are not set as specified in chapter. 3.6. b) DIP switches contact error c) shortcircuit at the start inputline	a) Check the orange Dip-switch 3 and blue Dip-switch 6 (refer page 10) b) Change Dip-switches 3 and 6 and switch back again c) Check connection, wiring at the start inputline
yellow and / or Orange flashing quickly (ca 4 x /s) <small>LS frei</small> <small>LC free</small> Fault! <small>LS unterbrochen</small> <small>LC interrupt</small> <small>Justierhilfe</small> <small>Aide d'ajustement</small> <small>Wederanlauf sperre</small> <small>interdiction de redémarrage</small>	a) short-circuit, overcharge or side-circuit of the outputs OSSD1/OSSD2 b) Operating mode setting does not match the electric wiring and/or DIP switches are not set as specified in chapter. 3.6. c) DIP switches contact error d) External or Internal error e) Electromagnetic interferences	a) check connection, wiring and output charge (max. 0,5A!) b) Check operating mode setting and wiring c) Change all Dip-switches and switch back again d) Switch off power supply and then switch on again. If LED still flashes: Disconnect all connections after having turned of the light curtain except for the power supply, and set the DIP-switches onto the operating mode: no restart interlock, no contactor control and equivalent outputs. If the LED continue flashing, a second emitter was recognized (refer to page 18) or receiver is defect, replace the receiver. e) use insulated brackets.
yellow and / or Orange flashing slowly (ca 1 x /s) <small>LS frei</small> <small>LC free</small> <small>LS unterbrochen</small> <small>LC interrupt</small> <small>Justierhilfe</small> <small>Aide d'ajustement</small> <small>Wederanlauf sperre</small> <small>interdiction de redémarrage</small>	a) In operating mode with contactor check: Contactors not responding or not fallen b) only BLVT: no fault if the green LED is also on and operating mode is floating blanking or reduces resolution	a) check contactor connections and contactor control wiring and connection (EDM) b) -
The green LED and the red LED turn, alternating back and forth operating mode: with contactor control, without restart interlock	OSSDs connect, contactors do not attract or error at the EDM inputline , OSSDs disconnect and connect again after shortly after that and so on	check contactor connections and contactor control wiring and connection (EDM)
for a short time the green LED is on, then Red and Yellow LED is on, operating mode: with contactor control, with restart interlock	OSSDs connect, contactors do not attract or error at the EDM inputline , OSSDs disconnect again	check contactor connections and contactor control wiring and connection (EDM)
just red LED on <small>LS frei</small> <small>LC free</small> <small>LS unterbrochen</small> <small>LC interrupt</small> <small>Justierhilfe</small> <small>Aide d'ajustement</small> <small>Wederanlauf sperre</small> <small>interdiction de redémarrage</small>	! only BLVT / ILVT! No + 24V DC on EDM, although EDM has been selected -- Supply voltage dropped more than 20%?	- check contactor connections and contactor control wiring and connection (EDM) - Or Correct setting modes - check power supply

Table 28/2 troubleshooting receiver

7.1 additional safety advices for the BLVT



all safety advices as stated in chapter 1 and in chapter 8 must be strictly observed!

Any incorrect use of the blanking features, i.e. their inappropriate integration into the function of the machine represent a potential danger. Therefore, the prerequisites for the use of the blanking function that are described in this instruction manual, must be thoroughly understood and strictly observed.

Normally, additional mechanical protective means are required in order to prevent machine operators from reaching into the hazardous area, getting past the blanked machinery parts.

Certain precautions must be taken in order to stop the machine if the additional mechanical protective means are removed from their place.

a. admissibility of the application: The various blanking features and their admissibility to the different operating modes must be thoroughly checked before their application. The light curtain BLVT combined with the programmer BLPG provides the various blanking functions. The admissibility of each application must be individually checked. This check of admissibility must also include if and how protection of the blanked sectors might be possible by additional mechanical protective measures, and the condition of the installation at the machine. The safety of the individual construction must be verified by an expert.

b. mechanical protective measures: additional mechanical protective devices besides the blanked machinery parts must be controlled by position switches as an integrated part of the safety chain, or, they must be fixed so that they cannot be removed by the use of regular tooling.

c. response time: compared to the light curtains ULVT, the response time of the BLVT is slightly longer. See chapter 4.1, page 13.

d. Programming the blanking functions: On special demand, Finessler Elektronik pre-programs each desired blanking pattern before delivery, or the customer himself may program the desired blanking patterns by using the programmers PLSG, BLPG and BPSG. See page 56. Programming of the blanking patterns must be carried out by authorized personnel only. This must be guaranteed by the use of a key-operated switch, provided by the customer. **This key must be kept separately from the installation at a secured place in order to prevent unauthorized personnel from illegal programming.** Having completed the programming procedure, the machine must not go into operation by itself. If the start interlock / restart interlock feature is not present within the light curtain, it must be realised within the next higher control.

e. Location of the key switch: The key switch must be installed at the machine in a position from which there is an unobstructed view onto the whole protective field.

f. After re-programming or after an exchange of the receiver, pass the corresponding test rod through the complete protective field for check. When doing so, make sure that the test rod is moved directly in front of the transmitter window, then close to the receiver window and then right in the middle of the protecting field between transmitter and receiver. (see fig. 29.4). During this test, neither the green LED nor the yellow LED must light up. By doing this, possibilities of the system failing to detect an obstruction as a result of reflection from some reflective objects in the programmed blanked areas are excluded.

g. Indication of the current resolution and of the protective field: The current resolution must be marked on special labels on the light curtain. If the light curtain is cleared, the blanking pattern "Reduced resolution" or "Floating Blanking" is indicated by the flashing of the yellow LED for "restart interlock" and the orange LED for "adjustment" at a frequency of 1Hz. A reduced resolution will effect the safe distance and must be drawn into its calculation accordingly.

h. The Blanking must cover the whole protective field width in order to prevent any reaching into the field by the operator. (see fig. 29.1, 29.2, and 29.3).

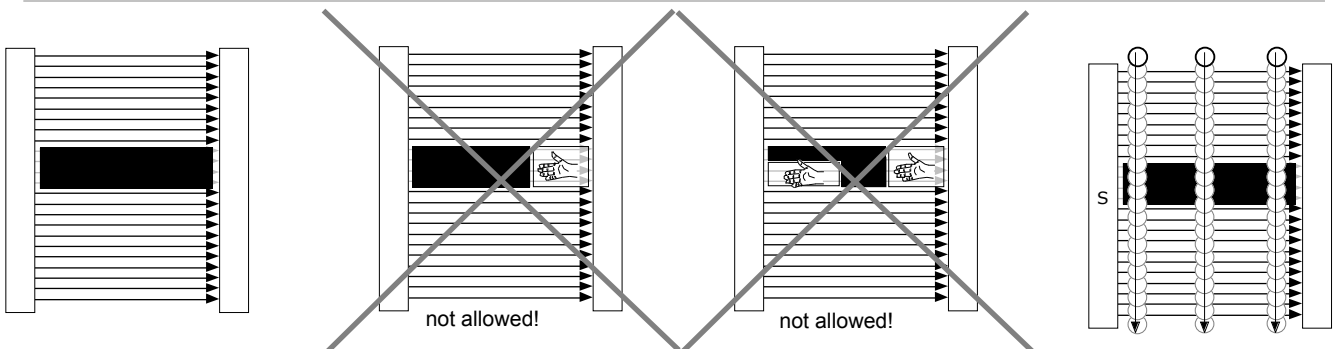

fig 29.1 Fixed Blanking or Floating Blanking with full utilization of the blanked sector of the light curtain.

fig 29.2 Fixed Blanking or Floating Blanking with **only partial utilization** of the blanked sector of the light curtain. Additional covering is required.

fig 29.3 Fixed Blanking or Floating Blanking with **only partial utilization** of the blanked sector of the light curtain. Additional covering is required.

fig 29.4 passage of a corresponding test rod through the whole protective field

7.2 Typical applications of the several blaking patterns

The **Blanking features** provide the "skipping " or "blanking" of parts of the protective field. By doing this, parts of tools or machinery may reach into the protective field without the reducing the function of the machine.

blanking patterns	typical application
1. blanking features OFF	complete protection in the entire protective field. Resolution and application same as ULVT.
2. fixed blanking fig 30/1	This blanking pattern provides stationary blanking of up to 5 light curtain sectors of any height. (e.g. insertion table or material feeder device)
3. fixed blanking with 1-beam reduced resolution fig. 30/2	combination of 2. and 8. Blanking of up to 5 objects which are fixed in the protective field, and additional blanking of thin moving objects (e.g. hoses or cables) that reach into the field occasionally or permanently, and, by doing so, will interrupt max. 1 beam.
4. fixed blanking with 2-beam reduced resolution fig 30/3	combination of 2. and 8. Blanking of up to 5 objects which are fixed in the protective field, and additional blanking of thin moving objects (e.g. hoses or cables) that reach into the field occasionally or permanently, and, by doing so, will interrupt max. 2 beams.
5. floating blanking fig 30/1	blanking of an object that is moving in the protective field . (e.g. vertically adjustable table)
6. floating blanking with 1-beam reduced resolution fig 30/2	combination of 5. and 8. Blanking of an object which is moving in the protective field, and additional blanking of thin moving objects (e.g. hoses or cables) that reach into the field occasionally or permanently, and, by doing so, will interrupt max. 1 beam.
7. floating blanking with 2-beam reduced resolution Bild 30/3	combination of 5. and 9. Blanking of an object which is moving in the protective field, and additional blanking of thin moving objects (e.g. hoses or cables) that reach into the field occasionally or permanently, and, by doing so, will interrupt max. 2 beams.
8. 1-beam reduced resolution fig 30/4	blanking of thin moving objects (e.g. hoses or cables) that reach into the field occasionally or permanently, and, by doing so, will interrupt max. 1 beams.
9. 2-beam reduced resolution fig 30/5	blanking of thin moving objects (e.g. hoses or cables) that reach into the field occasionally or permanently, and, by doing so, will interrupt max. 2 beams.
10. skip only 1 beam fig 30/6	A flat metal sheet may reach at any position (except for the synchronization beam) into the protective field, 1 beam will be skipped once. (i.e. for blanking of thin sheet metal in press brakes).
11. skip only 2 beams fig 30/7	A flat metal sheet may reach at any position (except for the synchronization beam) into the protective field, 2 beam will be skipped once. (i.e. for blanking of thicker sheet metal in press brakes).

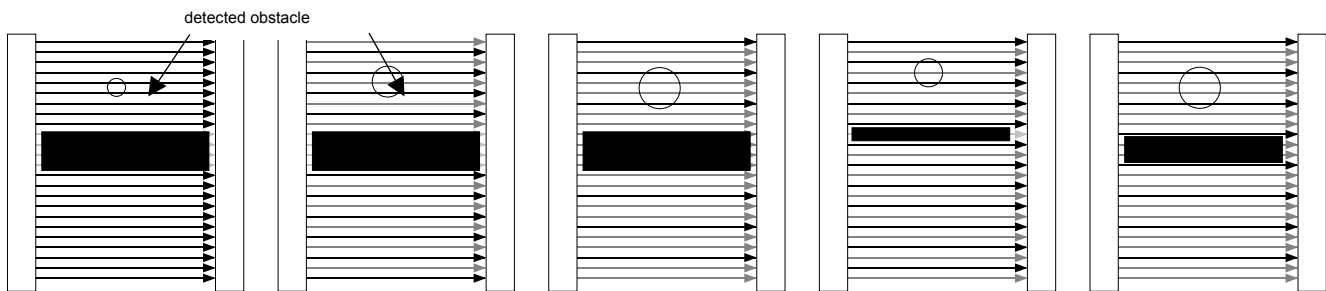

fig 30/1 fixed or floating blanking

fig 30/2 fixed or floating blanking, resolution reduced by 1 beam

fig 30/3 floating blanking with resolution reduced by two beams

fig 30/4 one beam reduced resolution as often as needed

fig 30/5 two beams reduced resolution, as often as needed

Green LED is on

Yellow and / or

Orange LEDs are flashing

slowly (ca 1 x /s) if the Op-mode is reduced resolution or floating blanking (rever to page 31)

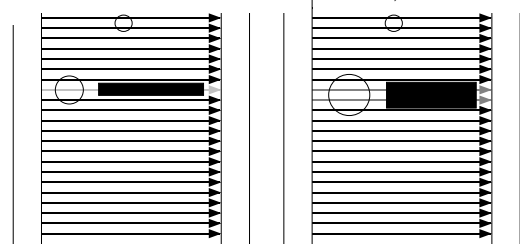

fig 30/6 skip one beam once

fig 30/7 skip 2 beams once

7.3 Important advices, restrictions and explanations of the resolutions of the different blanking patterns

Caution, synchronizing beam: The first beam (seen from the plug end) must never be masked, because this first beam serves as a synchronization means for transmitter and receiver. If this first beam is masked during the teaching/programming procedure, the light curtain will turn into error mode. Both orange and yellow LEDs on the receiver will start to flash quickly (ca. 4 x /s). If during operation, the synchronizing beam is interrupted, the outputs of the BLVT will be shut off.

The blanked sectors must cover the whole length of the protective field between transmitter and receiver in order to prevent any reaching into the field from the side.

Missing obstacles in the blanked sectors or obstacles with diameters others than programmed will deactivate the outputs of the BLVT light curtain.

blinking patterns	important advices and restrictions	resolution at beam spacing 7,5 mm / 14 mm	LED-display
1. blanking features OFF	the slightly longer response time of the BLVT compared to the ULVT applies here too (refer to tables on page 13)	full resolution, same as standard ULVT : 14 mm / 30 mm	no flickering
2. fix blanking fig 30/1	Blanking of up to 5 objects which are fixed in the protective field During operation, the position of the blanked sectors may be swaying ± 1 beam upwards and downwards. During operation, the number (extent) of the programmed blanked beams must never increase, but can be only reduced by only one beam. You should program only the sectors in those positions where the blanking will mask as many receiver elements as possible, otherwise problems caused by vibrations might occur. However, if only 1 beam is blanked, this one must not be cleared. During programming, at least three beams must remain cleared between the sectors.	full resolution outside the blanked sectors: 14 mm / 30 mm	no flickering
3. fix blanking resolution reduced by 1 beam fig 30/3	same as no. 2, but: During programming, between the blanked sectors, at least 5 beams must be free. Additionally, only 1 beam may be interrupted at any number of positions. (except for the synchronization beam)	reduced resolution outside of the blanked sectors: 22 mm / 42 mm	yellow/orange LED flicker at ca. 1 Hz
4. fix blanking resolution reduced by 2 beams fig 30/3	same as no. 2, but During programming, between the blanked sectors, at least 7 beams must be free. One, or max. 2 adjacent beams may be additionally be interrupted at any number of positions.) (except for the synchronization beam)	reduced resolution outside of the blanked sectors: 29 mm / 56 mm	yellow/orange LED flicker at ca. 1 Hz
5. floating blanking fig 30/1	1 sector (at least 2 adjacent beams) , that is permitted to move within the protective field during operation, can be blanked . During the programming, this sector must not move. The number of the programmed beams of the blanked sector must not increase by the vibrations of the machine during operation, but it may decrease by one beam.	full resolution outside the blanked sectors: 14 mm / 30 mm	yellow/orange LED flicker at ca. 1 Hz
6. Ortsvariable Ausblendung resolution reduced by 1 beam fig 30/2	same as no. 5, but: The blanked sector must interrupt at least 3 adjacent beams. Additionally, every one beam may additionally be interrupted at any number of positions. (except for the synchronization beam)	reduced resolution outside of the blanked sectors: 22 mm / 42 mm	yellow/orange LED flicker at ca. 1 Hz
7. Ortsvariable Ausblendung resolution reduced by 2 beams fig 30/3	same as no. 5, but: The blanked sector must interrupt at least 4 adjacent beams. Additionally, every one beam, but max. 2 beams may additionally be interrupted at any number of positions. (except for the synchronization beam)	reduced resolution outside of the blanked sectors: 29 mm / 56 mm	yellow/orange LED flicker at ca. 1 Hz
8. resolution reduced by 1 beam fig 30/4	Every one beam may be interrupted at any number of positions. (except for the synchronization beam) If there is more than one object within the protective field, there must be at least one beam in-between that remains free.	reduced resolution : 22 mm / 42 mm	yellow/orange LED flicker at ca. 1 Hz
9. resolution reduced by 2 beams Bild 30/5	One beam or max. 2 beams may be interrupted at any number of positions. (except for the synchronization beam) If there is more than one object within the protective field, there must be at least one beam in-between that remains free.	reduced resolution : 29 mm / 56 mm	yellow/orange LED flicker at ca. 1 Hz
10. skip 1 beam only once fig 30/6	1 beam may be interrupted at any one position within the protective field. (except for the synchronization beam)	no obstacle: 22 mm / 42 mm with obstacle: full resolution of the remaining protective field 14 mm / 30 mm	yellow/orange LED flicker at ca. 1 Hz
11. Skip 2 beams only once fig 30/7	2 beams may be interrupted at any one position within the protective field. (except for the synchronization beam)	no obstacle: 29 mm / 56 mm with obstacle: full resolution of the remaining protective field 14 mm	yellow/orange LED flicker at ca. 1 Hz

7.4 Programmiers for programming the blanking functions.

For detailed directions please refer to the instruction manuals for the respective Programmiers!

The programming remains permanently stored within the BLVT-Light curtains even after a voltage interruption.

7.4.1 PLSG3/K: Universal switching unit and Programmer for BLVT blanking functions.

Simple programming procedure (for more detailed instructions please refer to the operating instructions PLSG)

The programmer PLSG3 simply snaps onto the light curtain or can be connected by an adaptor cable.

1. The programming of the blanking function is realized by 4 HEX switches.
2. The objects to be blanked must be located within the protecting field.
3. then, just connect the operating voltage. The selected blanking function and the blanking position will be saved permanently by the BLVT-light curtain.

The programmer is not necessarily required for the operation of the BLVT and may be removed after having terminated the programming.



Bild 32/1

7.4.2 BLPG: Blanking-Programmer.

The programming of the blanking function is realized by 4 HEX switches. The programmer is not necessarily required for the operation of the BLVT and may be removed after having terminated the programming.

7.4.3 BPSG: Blanking-Programmer and switching unit

same as BLPG, but provides additional power supply and positively driven relays with potential-free outputs. Programming is made by activating a key-switch.

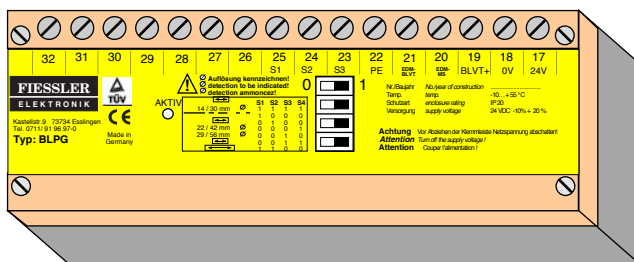

fig 32/2

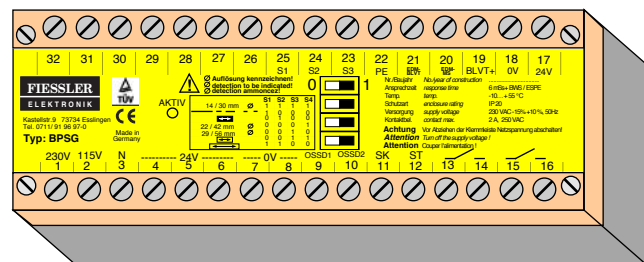

fig 32/3

Easy and simple programming procedure: (valid only for the switching units BLPG und BPSG) (please refer to the detailed instructions in the operating instructions BPLG/BPSG)

1. Enter the desired blanking function via the DIP-switches.
2. The objects to be blanked must be located within the protecting field.
3. Turn the key switch into the "Programming"-position. Wait until the green LED at the switching unit indicates that the switching unit is now ready to be programmed.
4. Remove the key switch from its lock. When the green LED "AKTIV" is off, the programming procedure is terminated.

7.5 How to save up to 5 different blanking patterns and how to activate them via selector switch

The BLVT in connection with the programmiers BLPG or BPSG and an external selector switch is able to save up to 5 different blanking patterns, which can be activated via this selector switch.

For this function, please refer to the detailed instructions in the operating instructions of the programmiers!

8.1 additional safety instructions for cascaded light curtains



All safety advices as stated in chapter 1 and in chapter 7 must be strictly observed!

Mix of category 4 and category 2: The admissability of a combination of systems belonging to category 4 and category 2 always depends on the results of the risk assessment of the installation! Any light curtain of category 2 will not be automatically upgraded to a category 4 light grid! It must be made sure that the main sensor (Master sensor) is a light curtain of category 4 in order prevent the system to be completely downgraded to category 2!

Arrangement of the light curtains: It must be made sure that the mutual clashing of the light curtains is prevented. (refer alsot o chapter 4.3.5 page 18)

length of cables: The cable length between the cascaded light curtains must not exceed 10 m.

Response times / Safe distance : In case of any interruption of a cascaded light curtain, the response time will increase for 3 ms per preceding light curtain. This must be drawn into the calculation of the safe distance.

Arrange only **protective fields by using compatible components** (i.e. Master sensor receiver with master sensor transmitter)

8.2 Application examples:

a) Protection at the 3 sides of a C-press without the obstacles of vertical tilted mirrors .

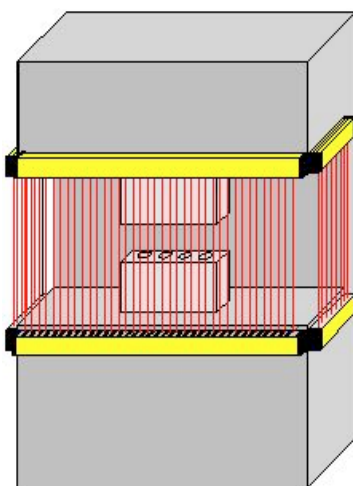

fig 33/1 Protection at a C-Press

b) Protection against walking behind the light curtain

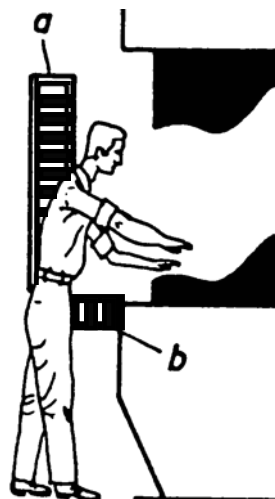

fig 33/2 Protection against walking behind

c) Protection at the rear side of the press

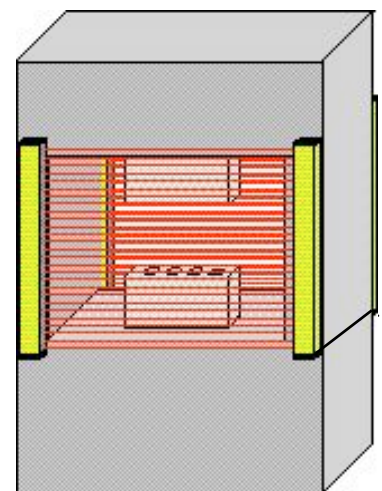

fig 33/3 protection at the rear of the press

8.3 How to utilize and combine the light grids

All standard sizes and resolution types of the light grids of the ULVT and BLVT series (category 4) as well as those of the TLVT and ILVT (category 2) series are available as cascading light grids and can be combined with each other. If you combine categories 2 and 4: please refer to the safety instructions.

Cascading light grids are slightly modified light grids with an additional connector for a secondary light curtain. They are characterized by the letter "K" in their order code (e.g. ULVTK).

Up to 3 light curtains may be connected in series (cascaded). The cascading of the light curtains considerably reduces the wiring expenditure. Only the master-sensor receiver is connected to the machine control and stops the dangerous movement. Only the master sensor transmitter is connected to the main power supply.

The Master sensor and the light grid in the middle must each be **cascadable** light grids. **Cascadable** light grids always require a secondary ("slave sensor") light grid, therefore the **cascadable** light grids are not to be used as stand-alone light grids.

In the cascade, the last secondary light grid is always a standard light grid. This can also be used as a stand-alone light grid.

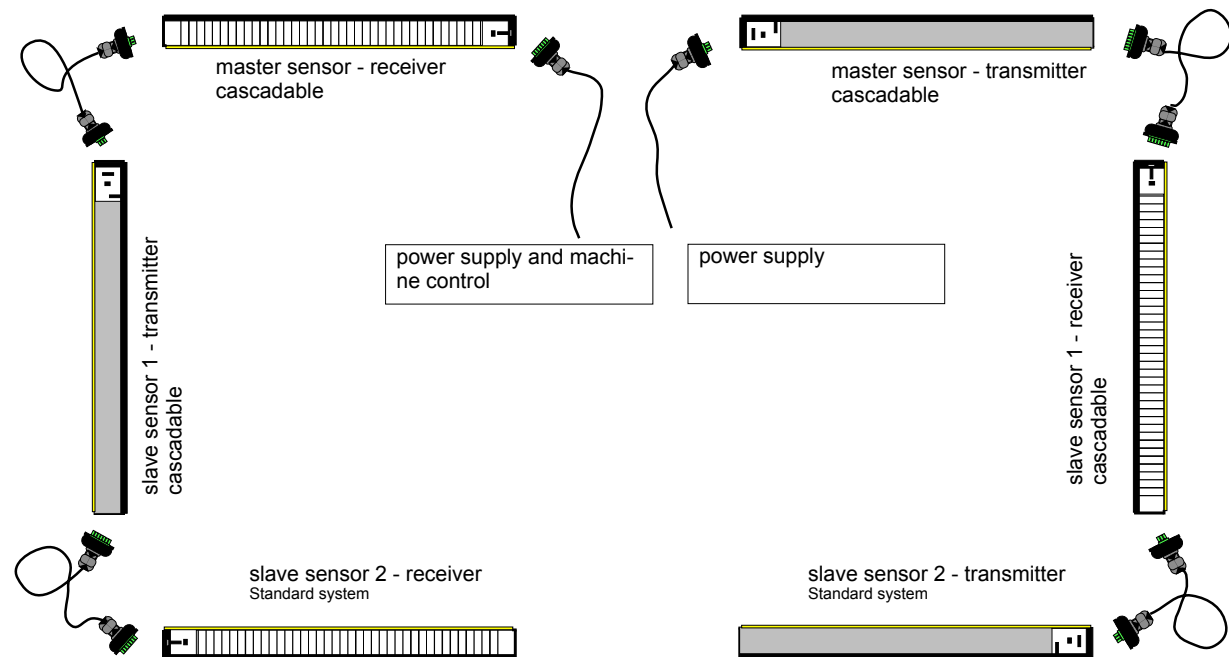

fig 34/1

8.4 order codes: (examples)

a. Cascading of 2 light curtains

Safety light grid with protection height 1300 mm, 14 mm resolution
 Safety light grid with protection height 400 mm, 30 mm resolution

Master sensor: cat. 4
 slave sensor: cat. 4

	System	Protective height	number of beams
master sensor:	ULVT-K	1300	/169
slave sensor:	ULVT	400	/28

b. Cascading of 3 light curtains

Safety light grid with protection height 800 mm, 400 mm resolution
 Safety light grid with protection height 1200 mm, 14 mm resolution
 Safety light grid with protection height 400 mm, 30 mm resolution

Master sensor: cat. 4
 slave sensor 1: cat. 4
 slave sensor 2: cat. 4

	System	Protective height	number of beams
master sensor:	ULVT-K	800	/3
slave sensor 1:	ULVT-K	1200	/156
slave sensor 2:	ULVT	400	/28

8.5 Response times of cascaded light grids

The cascaded light grids detect any interruption of the protection field of the secondary ("slave") sensor within 3ms. The response time of the respective light grids is obtained by adding the individual response time to 3ms for each preceding light grids.

Master sensor individual response time (as shown on the type plate)

Slave sensor1 individual response time + 3 ms

Slave sensor2 individual response time + (2 x 3 ms = 6 ms)

The own response time is stated on the type plate of the respective light grid.

The table on page 13 shows the individual response times for all standard light grids.

example:	response times
Master sensor ULVTK 500/65	9 ms
Slave sensor1 ULVTK 500/35	7 ms + 3 ms = 10 ms
Slave sensor2 ULVT 800/3	4 ms + 6 ms = 10 ms

Table 35/1 response times cascaded light curtains

8.6 safe distance of cascaded light grids

When calculating the safe distance of the light grids (refer to chapter 4.2), it must be considered that each preceding light grid will increase the response time of the cascaded light grid by 3ms.

Calculation example:

	Resolution see tables page 13	individual response time of the light grid, see tables page 13	calculated response time	safe distance (Formula: refer to chapter 4.2.1)
Master sensor ULVTK 500/65	14 mm (C= 0 mm)	10 ms	same as individual re- sponse time= 10 ms	S = 170 mm
slave sensor 1 ULVTK 1500/195	14 mm (C= 0 mm)	21 ms	21 ms + 3 ms = 24 ms	S = 198 mm
slave sensor 2 ULVT 500/35	30 mm (C= 128 mm)	7 ms	7 ms + 6 ms = 13 ms	S = 176 mm + 128 mm = 304 mm

Tabelle 35/2 calculation example safe distance of cascaded light grids

Table for calculating of the respective response times of your utilized cascaded light grids :

	resolution s. tables S. 13	individual response time of the light grid, see tables page 13	calculated response time	safe distance (Formula: refer to chap- ters 4.2.1, 4.2.2, or 4.2.3)
Master sensor				S =mm
Slave sensor 1		 +3 ms =	S = mm
Slave sensor 2		 +6 ms =	S =mm

Tabelle 35/3

8.8.2 connection example 2: Master sensor **ULVTK** (category 4), Slave sensor **TLVT** (category 2)
Operating mode: with restart interlock, with contactor control.

The connection of the master sensor to the voltage supply and to the machine control system ist made as described in chapter 5 **Electrical connection**. The cable length between the cascaded light grids must not exceed 10m.

The desired operating mode is set only at the master sensor. (refer to chapter 3.6 **operating modes selector**.) On the slave sensors, the operating mode must be set onto: **no restart interlock, no contactor control, equivalent** outputs !

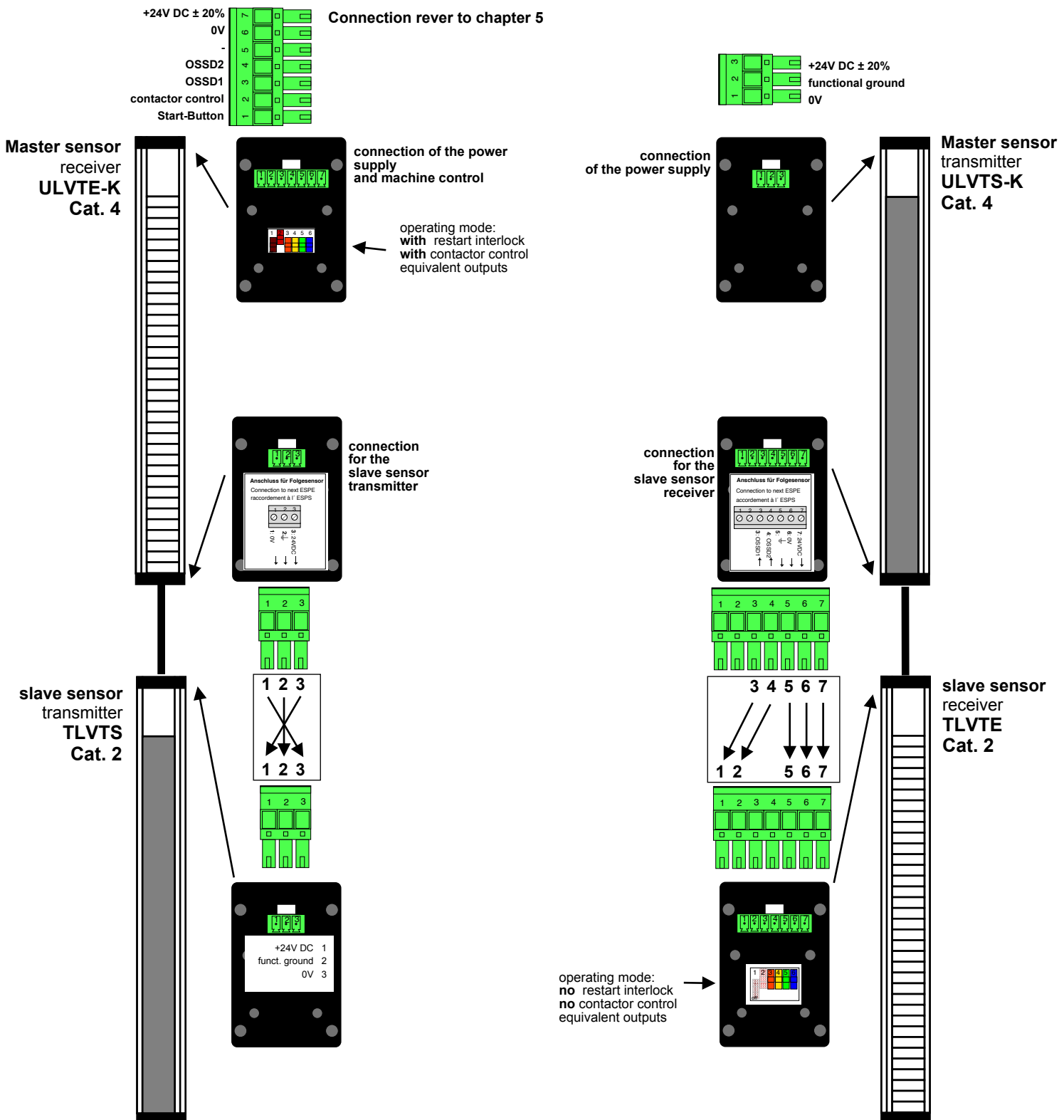

fig 37/1

8.9 Commissioning of cascading light grids (All instructions in chapter 6 Commissioning are strictly to be observed).

Adjustment of the light grids: --> **Caution:** The correct adjustment of the transmitters onto their receivers must always start with the last light curtain of the cascade, as the preceding light curtains only go into "free" state after the succeeding (last one) light curtains are have switched to "free" state.

The cascading transmitters indicate the interruption in the protective field of the connected receiver by short flickering (once per second) of the yellow LED. If the protective field of the connected receiver is free, the yellow LED will light up permanently and the transmitter is in transmitting state.

- LEDs on the receiver**
- OSSD's on (aktivated)
 - OSSD's off (deaktivated)
 - insufficient reserve
 - restart interlock

adjustment order:
step 1:

slave sensor 2 adjust at first

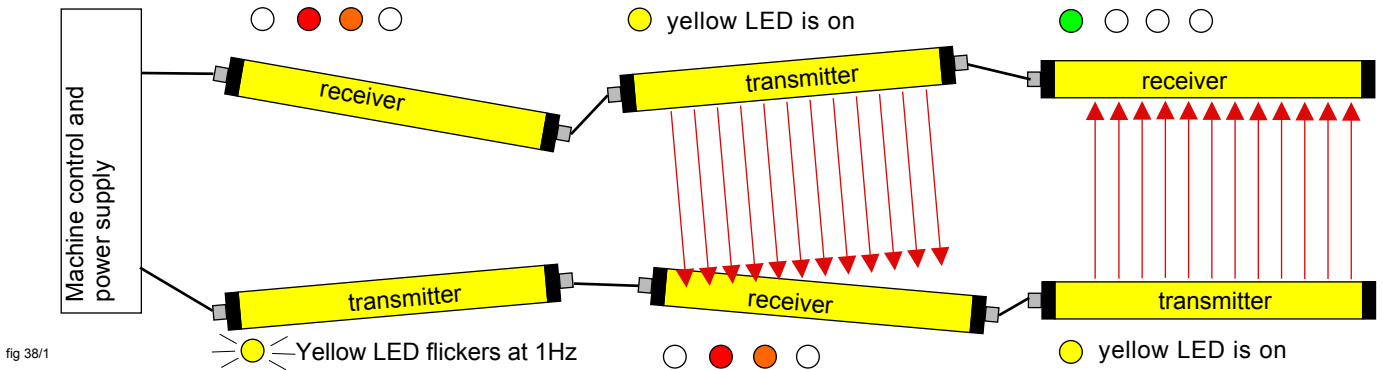

fig 38/1

step 2:

slave sensor 1 second to be adjusted

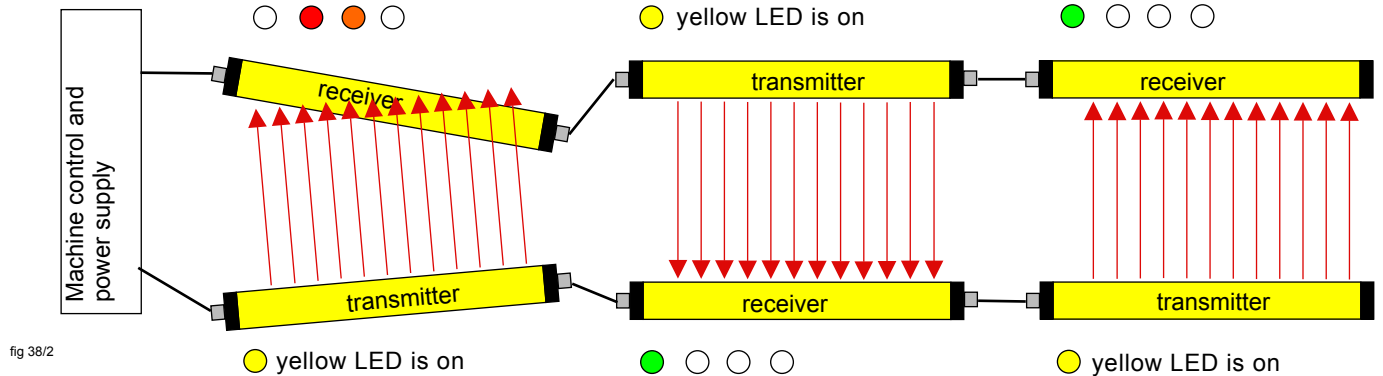

fig 38/2

step 3: master sensor last to be adjusted

the green or yellow LED will be on (depending on operating mode), if the master sensor is correctly adjusted

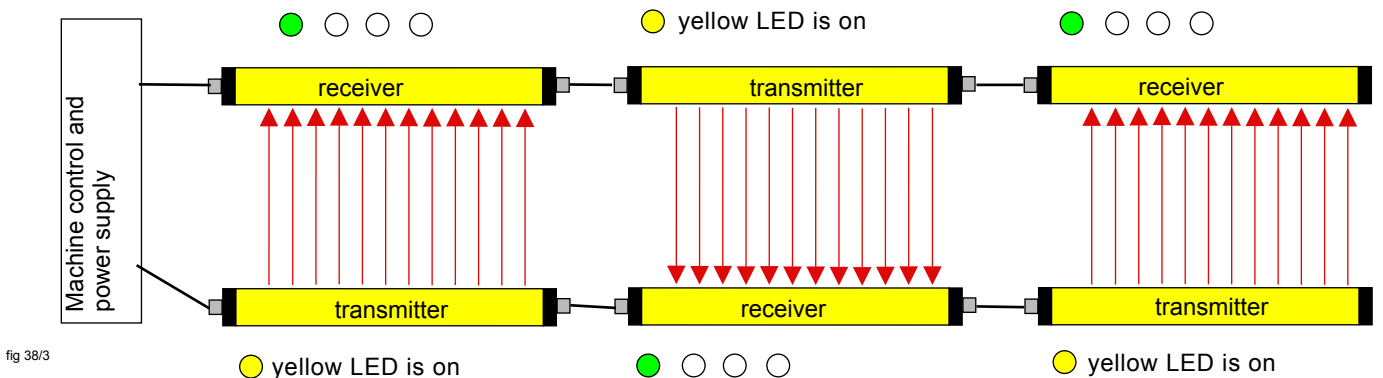
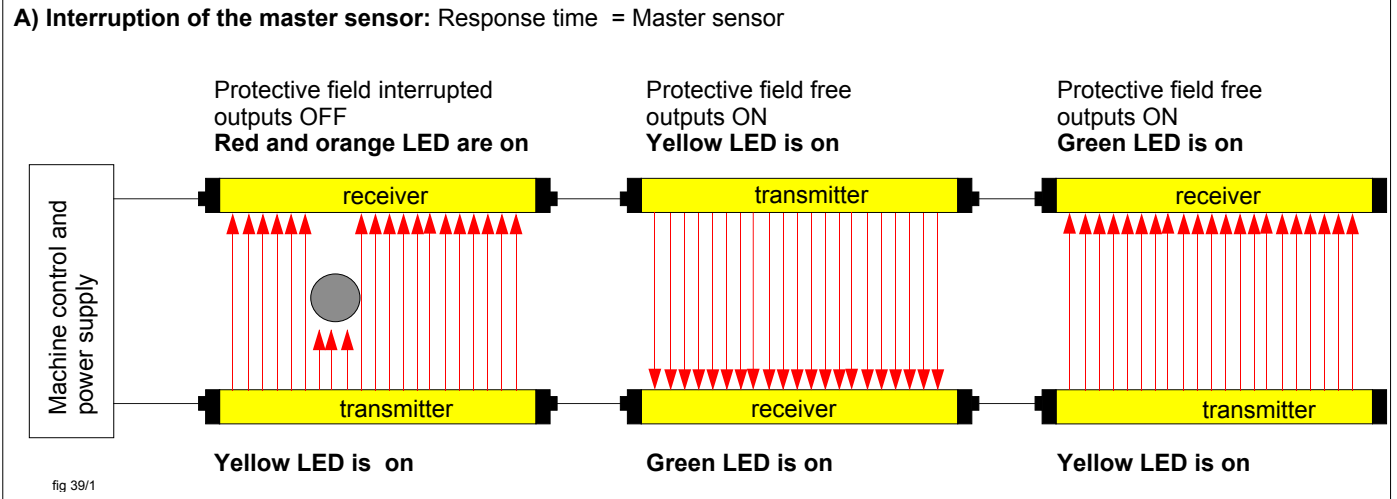

fig 38/3

8.10 Protective Field States / LED-displays

A) Interruption of the master sensor: Response time = Master sensor



B) Interruption of the slave sensor 1: Response time = slave sensor 1 + 3

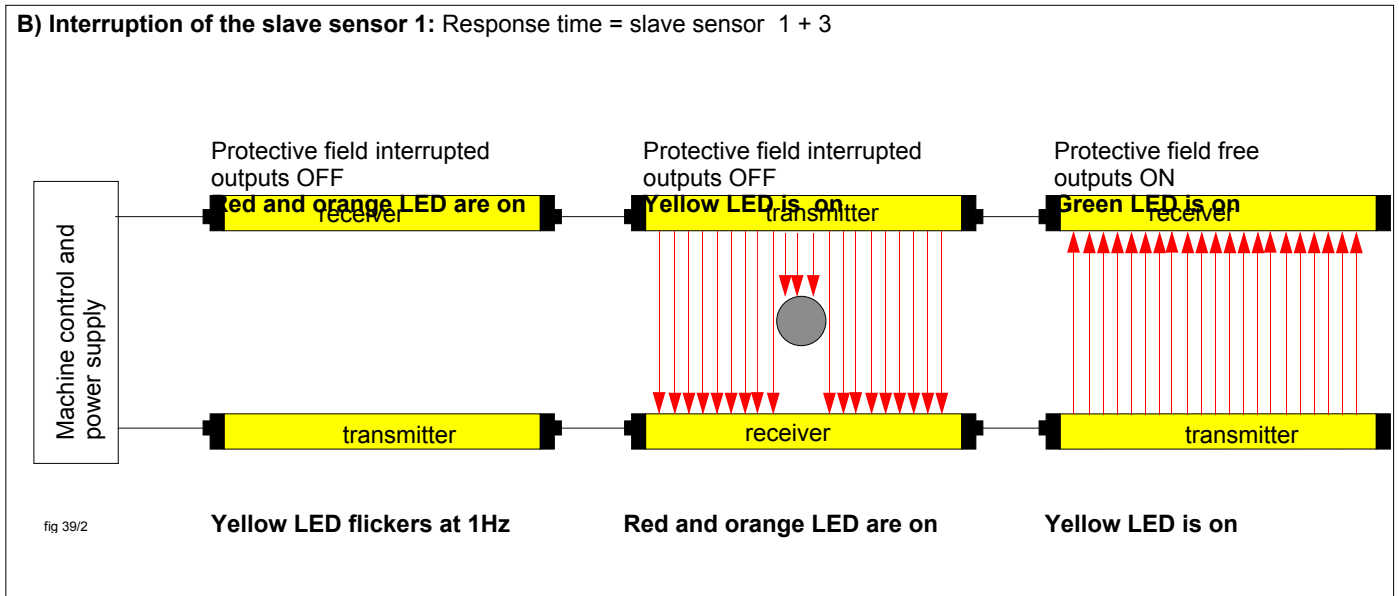

C) Interruption of the slave sensor 2: Response time = slave sensor 2 + 6 ms

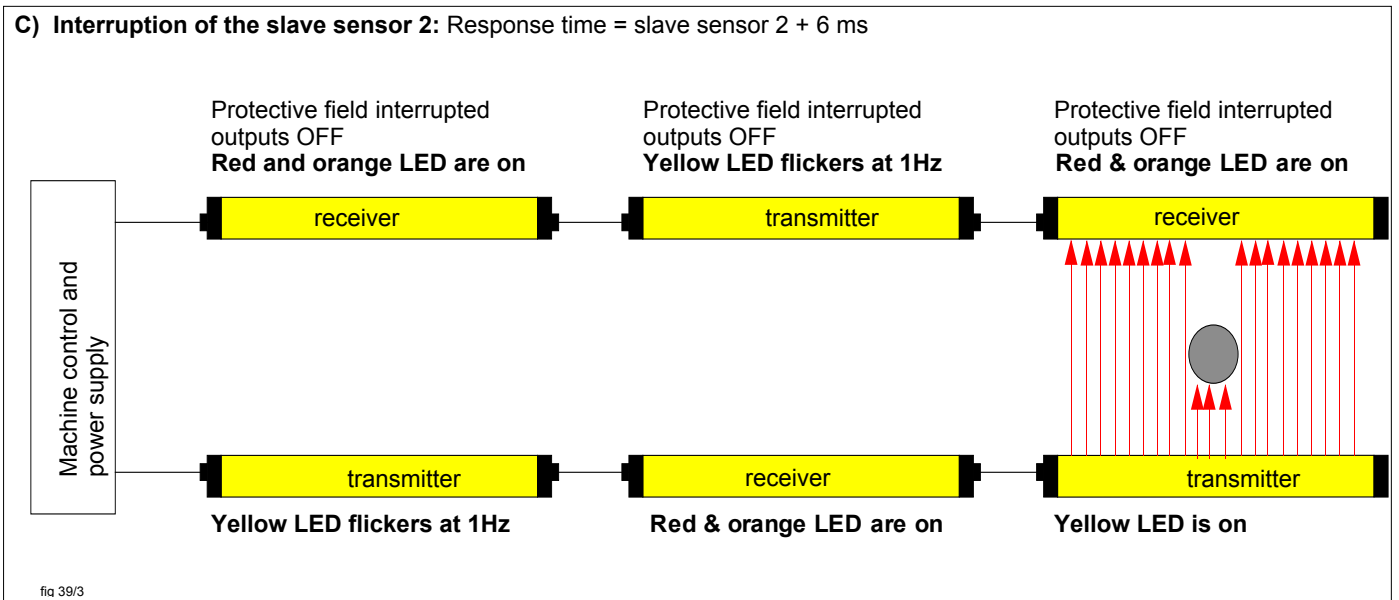

For additional functions such as **Muting**, **Cycle mode**, **Emergency-OFF-circuit** - or **potential free output contacts etc.**, safety switching units are available as option.

For detailed information and description of the functions as well as for further information, please refer to the operating instructions of the safety switching units.



fig 40/1

PLSG...

ULVT
or
BLVT

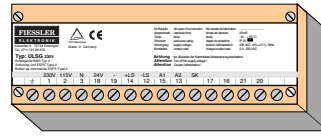

ULSG

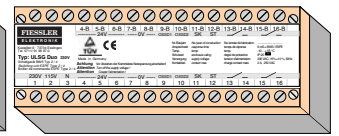

ULSGDUO

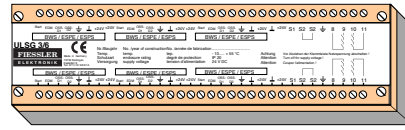

ULSG3/6



PLSG...K

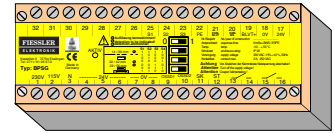

BPSG

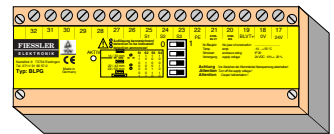

BLPG

Safety switching unit additional function	PLSG1 Muting switching unit	PLSG2 Muting switching unit	PLSG3 Universal switching unit / con- troller	PLSG1K Muting switch- ing unit	PLSG2K Muting switch- ing unit	PLSG3K Universal switching unit / con- troller	BLPG BLVT-Pro- grammer	BPSG BLVT-Pro- grammer	ULSG ULSGDUO ULSG3 ULSG6 switching unit
Muting (short bridging / disabling of the light curtain)	●	●	●	●	●	●	-	-	-
cycle mode protection and control mode in case of cyclic entering into the protective field (e.g. inserting work)	-	-	1-cycle, 2-cycle, 3-cycle or 4- cycle mode	-	-	1-cycle, 2-cycle, 3-cycle or 4- cycle mode	-	-	-
Potentialfree Switching contacts	-	-	-	optional ...1KR	optional ...2KR	optional ...3KR	-	●	●
selector mode switching between operating modes and / or blanking modes	-	-	in connection with BLPG or BPSG: (see columns to the right)	-	optional ...2KP	optional ...3KP	up to 5 PLSG-operating modes / BLVT-blanking patterns	up to 5 PLSG-operating modes / BLVT-blanking patterns	-
connection of 2 to 6 light curtains	-	-	-	-	-	-	-	-	ULSGDUO: 2 ULSG3: 3 ULSG6: 6
restart interlock only during the work movement	-	-	●	-	-	●	-	-	-
BLVT-blanking functions program 11 blanking patterns	-	-	●	-	-	●	●	●	-
Emergency-OFF-circuit -connection and -monitoring	-	-	●	-	-	●	-	-	-
2-Hand-Start button -connection and monitoring	-	-	●	-	-	●	-	-	-
Override after an unscheduled Stop	●	●	●	●	●	●	-	-	-
Voltage supply	24 VDC	24 VDC	24 VDC	24 VDC	24 VDC	24 VDC	24 VDC	24 VDC, 115 VAC, 230 VAC	24 VDC, ULSG/...DUO: 115 VAC, 230 VAC
aluminium profile housing, snap-on fastening onto light grids (ULVT/BLVT only)	●	●	●	-	-	-	-	-	-
Display 2 x 8 digits LCD	-	●	●	-	●	●	-	-	-

Accessories	weight	order code	
Anti-Vibration brackets, for individual fastening point (in the case of vibrations of the machine)	110g	SM	refer to page 21
angular-shaped brackets	150g	BW-K	refer to page 20
test rod 14 mm diam. with fastening clips (for carrying out the daily inspection)	30g	PS 14	-
test rod 30 mm with chain (for carrying out the daily inspection)	210g	PS 30	-
tilted mirrors	dependig on constructional height	USP 100 ... USP 2000	refer to page 21 & 22
assebly columns for transmitter/receiver	dependig on constructional height	SAU 100 ...SAU 1900	refer to page 23 & 24
assebly columns with tilted mirrors	dependig on constructional height	SASU 100 ...SASU 1900	refer to page 23 & 24
Shock-protection columns for transmitter/receiver	dependig on constructional height	SDU 100 ...SDU 1900	refer to page 23 & 24
Shock-protection columns with tilted mirrors	dependig on constructional height	SDSU 100 ...SDSU 1900	refer to page 23 & 24
Laser adjustment device	400g	JL2	refer to page 27
Spare parts			
Standard aluminium fastening brackets, with plastic parts enabling an insulated installation	80g	BLAL	refer to page 19
Set of plastic parts enabling an insulated installation of the brackets	10g	-	refer to page 19
connection lid, with terminal screws, transmitter	50g	AD/S	-
connection lid, with terminal screws, receiver	50g	AD/E	-
Available equipment modification			
front window pane made of silicate glass (solvent-resistant)	depending on con- structional height	UGL 100 ... UGL 2000	-
protection in EX-zones	-	EXP	-

Service

If you have questions that cannot be answered by reading this operation instruction manual, please contact us directly.

When calling, please have the following data ready:

- Exact unit type and model
- Serial number(s)
- Symptom of the malfunction and/or fault description

Fiessler Elektronik GmbH & Co. KG
Buchenteich 14
D-73773 Aichwald

Phone: ++49(0)711-91 96 97-0
Fax: ++49(0)711 / 91 96 97 - 50
E-mail info@fiessler.de

Maintenance

The devices of the series of ...LVT are maintenance-free.

On request by the customer, Fiessler Elektronik GmbH & Co. KG carries out the acceptance test and annual inspections.

In addition, seminars providing customers with training in annual inspections are held at regular intervals.

Warranty

The company Fiessler Elektronik GmbH & Co. KG refuses to accept any warranty claims if the device has been opened or if it has been modified.

Returning a unit

If, in the case of default, the necessity of returning the unit to Fiessler Elektronik arises, it will be very advantageous for a fast default diagnosis if the following topics are observed and observed:

- exact description of malfunction:
 - did you frequently notice malfunctions at the machine where the light curtains are installed?
 - any defaults or malfunctions in the past?
 - etc..
- which operating mode has been used with this unit?

The more exactly the malfunction is described, the more accurate and faster we can determine it and repair it.

Download site

Please visit our homepage. Here you will find the most recent operating instructions, appliance descriptions, data sheets etc. ready for download at no charge.

<http://www.fiessler.de>

GESCHÄFTSLEITUNG

Konformitätserklärung

(gemäß Anhang II 1 A 2006/42/EG)

Wir

**Fiessler Elektronik
GmbH & Co. KG
Kastellstr. 9
D-73734 Esslingen,**erklären in alleiniger Verantwortung,
daß die Produkte**Sicherheits-Lichtvorhänge
ULVT/BLVT mit der
Register Nr. 01/205/0670/09,
(TÜV Rheinland)**auf die sich diese Erklärung bezieht,
mit den folgenden Normen oder norma-
tiven Dokumenten übereinstimmen:**EN 61496-1,
IEC 61496-2,
EN 61496-1/-2
EN 62061:2005
EN ISO 13849 -1
EN 954**Gemäß den Bestimmungen
der Richtlinie**2006/42/EG
2004/108/EG**Die Schutzziele der Niederspannungs-
richtlinie (2006/95/EG) wurden gemäß
Anhang I, Nr. 1.5.1 der Maschinenricht-
linie eingehalten.**Declaration of conformity déclaration de conformité**

(according appendix II 1 A 2006/42/EG)

We

**Fiessler Elektronik
GmbH & Co. KG
Kastellstr. 9
D-73734 Esslingen,**declare under our sole responsibility that
the products**Infrared accident prevention
safety barriers ULVT/BLVT with the
certificate no. 01/205/0670/09,
(TÜV Rheinland)**to which this declaration relates is in con-
formity with the following standards or ot-
her normative documents**EN 61496-1,
IEC 61496-2,
EN 61496-1/-2
EN 62061:2005
EN ISO 13849 -1
EN 954**

following the provisions of Directive

**2006/42/EG
2004/108/EG**The protection goals of the Low Voltage
Directive (2006/95/EC) have been compli-
ed with in accordance of Annex I
No.1.5.1 of the Machinery Directive.

(conforme appendice II 1 A 2006/42/EG)

Nous

**Fiessler Elektronik
GmbH & Co. KG
Kastellstr. 9
D-73734 Esslingen,**déclarons sous notre seule
responsabilité que le produit**Barrière de sécurité
ULVT/BLVT avec le numéro de
certificat 01/205/0670/09,
(TÜV Rheinland)**auquel se réfère cette déclaration est
conforme aux normes ou autres docu-
ments normatifs**EN 61496-1,
IEC 61496-2,
EN 61496-1/-2
EN 62061:2005
EN ISO 13849 -1
EN 954**conformément aux dispositions de
Directive**2006/42/EG
2004/108/EG**Les objectifs de protection de la
directive "basse tension" (2006/95/CE)
ont été respectées conformément à l'an-
nexe I n ° 1.5.1 de la directive Machines.**Folgende benannte Stelle hat eine positive Erklärung ausgestellt.**Kennnummer der benannten Stelle NB 0035
Prüfbescheinigung N° 01/205/0670/09
Name:
TÜV Rheinland

Esslingen, den / the / le 01.12.2010

Götz Fiessler / Geschäftsführer / Dokumentationsbevollmächtigter
/ managing director / authorized for documentation / gérant / mandataire de la
documentation

Additional safety products

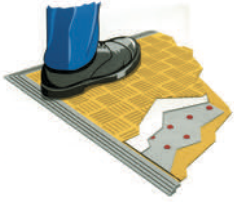

Safety switching mats



Safety Footpedal



Parametrizable safety controller **FPSC**

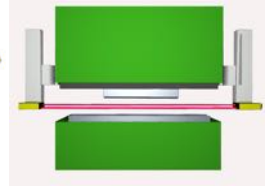

press brakes protection system **AKAS**



Light curtains for safety, control and measurement

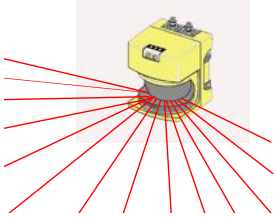

Laser scanners



Single-beam safety light barriers

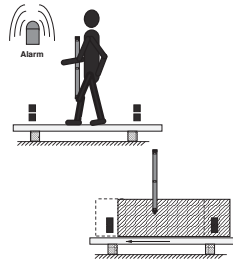

Safety light bars with muting function

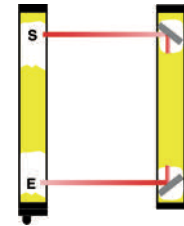

Safety light grids

Service

Safety seminars and integration support by our service team.

Certification

A quality management system was introduced at an early stage to guarantee the high quality of Fiessler safety equipment. Fiessler Elektronik is certified according to DIN ISO EN 9001. The company's own electromagnetic compatibility laboratory tests products on a regular basis. All safety equipment complies with national and European standards. Development takes place in consultation with the relevant trade associations. Certification is received followed rigorous tests by the Technical Inspection Board.



Recognition

by Baden Württemberg's ministry of economy of outstanding performance by the innovative AKAS safety system.



**Fiessler Elektronik
GmbH & Co. KG
D-73773 Aichwald**

Phone: ++49(0)711-91 96 97-0
Fax: ++49(0)711-91 96 97-50
Email: info@fiessler.de
Internet: www.fiessler.de

Represented in all major countries

