

# 3-PCS PREMIUM BALL VALVE

**TYPE 1211: STEEL**  
**TYPE 1311: STAINLESS STEEL**



## GENERAL

SIZE/PRESSURE:	1/4" - 1" FB = 125 BAR 1 1/4" - 1 1/2" FB = 100 BAR 2" - 4" FB = 64 BAR
TEMPERATUR:	-28°C TIL 220°C (STEEL - TYPE 1211) -38°C TIL 220°C (STAINLESS - TYPE 1311)
ISO TOP FLANGE:	EN ISO 5211
THREAD ENDS:	BSPP - EN ISO 228-1
BUTT WELD ENDS:	TYPE 1211 - EN 12627 TYPE 1311 - DIN 2463 / EN ISO 1127 LINE 1 - DIN 11850-2 (FB) - SMS 3008
BALL SURFACE HARDENING:	300HV
<b>OPTION</b>	
SIZE/PRESSURE:	5" - 6" FB = 25 BAR (EN ISO 1127)
EDITION:	FIRE SAFE API 607 AND ISO 10497
CONNECTION:	VARIOUS. BSPT, NPT, ANSI B 2.1, JISPT, SCH. 10 & 40, SOCKET WELD ENDS ANSI B 16.11
SEAT/PACKING:	PEEK, 50%SS/PTFE, DELRIN, CAVITY FILLER *FDA (PTFE+GLASS FIBRE / PTFE) SS
BALL HARDENING:	1200HV +/- 100HV

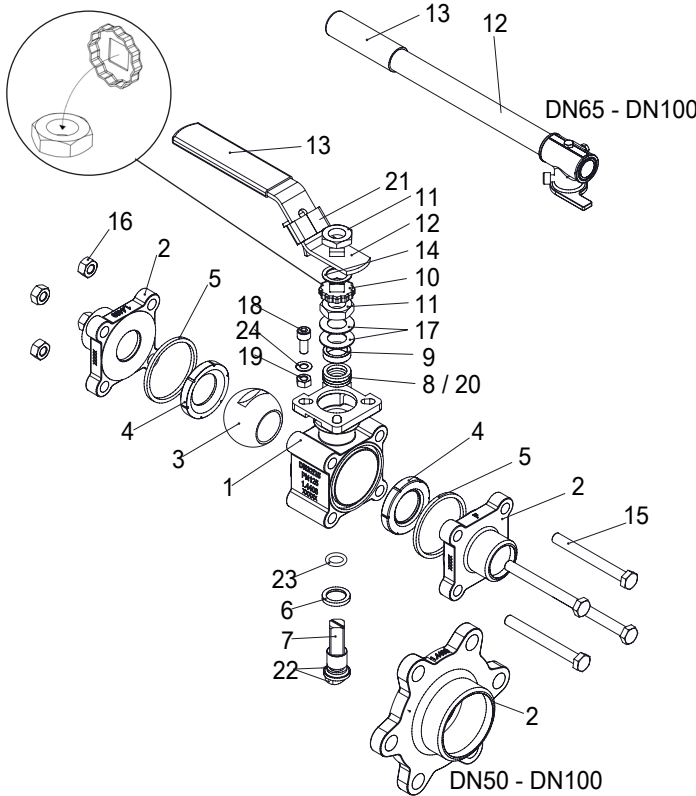

POS	DESCRIPTION	MATERIAL
1	BODY *	STAINLESS STEEL CF8M
2	CONNECTION *	STAINLESS STEEL CF3M/CF8M (THREAD)
3	BALL	STAINLESS STEEL AISI 316
4	SEAT PACKING	PTFE WITH 25% CARBON
5	JOINT GASKET	PTFE WITH 15% GLASS FIBRE
6	CONIC PACKING RING	PTFE WITH 25% CARBON
7	STEM	STAINLESS STEEL AISI 316
8	STEM SEAL	PTFE WITH 25% CARBON
9	GLAND	STAINLESS STEEL AISI 304
10	LOCK SADDLE	STAINLESS STEEL AISI 304
11	STEM NUT	STAINLESS STEEL AISI 304
12	HANDLE	STAINLESS STEEL AISI 304
13	HANDLE SLEEVE	VINYL
14	WASHER	STAINLESS STEEL AISI 304
15	BOLT	STAINLESS STEEL AISI 304
16	NUT	STAINLESS STEEL AISI 304
17	BELLEVILLE WASHER	STAINLESS STEEL AISI 301
18	STOP BOLT	STAINLESS STEEL AISI 304
19	NUT	STAINLESS STEEL AISI 304
20	BUSHING	75% PTFE/20% GLASS FIBRE/5% GRAPHITE
21	LOCKING DEVICE	STAINLESS STEEL AISI 304
22	ANTI-STATIC DEVICE	STAINLESS STEEL AISI 304
23	O-RING	FPM
24	WASHER	STAINLESS STEEL AISI 304

≥DN65FB includes backup for seat ring in stainless steel  
 \* Type 1211 A216 Gr. WCB

## DESCRIPTION

- Solid ball valve for high performance tasks.** All ball valves are pressure tested. Can on demand be delivered with certificate EN10204/3.1.
- PTFE with 25% carbon filled** are used for seats and pyramid segment. This material is very suitable for high pressure and temperature and it's even more resistant to wear than traditional PTFE.
- Antistatic stem with dynamic stuffing box.** Stem with 45° face of contact. This means larger contact area together with reinforced stem seat and a surface quality on Ra 0.2 ~ 0.3 um. These advantages provides the possibility of a very long lifetime.
- Approvals:** TA-Luft, EC1935 on stainless steel, ATEX, SIL3, TR TS 032/2013, 012/2011, 010/2011. Option: FDA

## SUITABLE FOR



DS-1211/1311-UK-09-2023-REV. J  
 We reserve the right for changes.

## DIMENSIONS

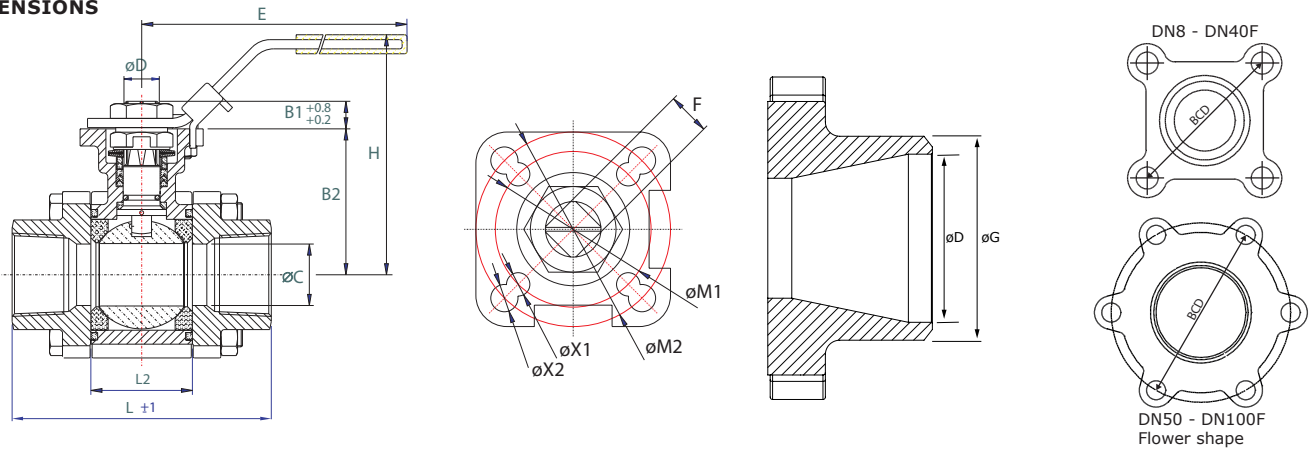

DIMENSION [MM]	VALVE WITH HANDLE									ISO TOP FLANGE				STEM		
	L [MM]			L2	B2	ØC	E	H	BCD	ISO 5211	ØM1	ØM2	ØX1X4	ØX2X4	F	B1
	THREAD	BW	SMS													
DN08FB	75.0	75.0	75.0	24.5	42.6	10.0	140	76.6	54.0	F03/F04	36	42	6.0	6	9	7.6
DN10FB/DN15RB	75.0	75.0	75.0	24.5	42.6	10.0	140	76.6	54.0	F03/F04	36	42	6.0	6	9	7.6
DN15FB/DN20RB	73.0	75.0	75.0	24.5	42.6	15.0	140	76.6	54.0	F03/F04	36	42	6.0	6	9	7.6
DN20FB/DN25RB	86.0	90.0	90.0	31.4	46.8	20.0	140	81.7	62.5	F03/F04	36	42	6.0	6	9	8.6
DN25FB/DN32RB	106.0	110.0	110.0	41.3	59.3	25.0	165	98.3	71.0	F04/F05	42	50	6.0	7	11	10.4
DN32FB/DN40RB	111.0	115.0	115.0	48.4	62.6	32.0	165	101.6	80.9	F04/F05	42	50	6.0	7	11	10.4
DN40FB/DN50RB	130.0	130.0	130.0	56.3	79.0	38.0	217	128.0	94.2	F05/F07	50	70	7.5	9	14	13.4
DN50FB/DN65RB	143.0	143.0	143.0	71.4	87.7	50.0	217	137.0	114.0	F05/F07	50	70	7.5	9	14	13.4
DN65FB/DN80RB	185.0	185.0	185.0	86.6	108.7	65.0	380	167.5	139.0	F07/F10	70	102	10.0	12	17	16.8
DN80FB/DN100RB	205.0	205.0	205.0	99.0	117.7	80.0	450	176.5	160.0	F07/F10	70	102	10.0	12	17	17.8
DN100FB	240.0	240.0	240.0	127.0	133.7	100.0	450	192.5	193.0	F07/F10	70	102	10.0	12	17	16.8

DIM		*)TORQUE		**)WEIGHT		KV-VALUE		BUTT WELD ENDS [R=REDUCE BORE] [F=FULL BORE]							
[MM]	[INCH]	FB [NM]	RB [NM]	FB [KG]	RB [KG]	90° M³/H		TYPE 1211		TYPE 1311		TYPE 1311		TYPE 1311	
						FB	RB	EN 12627		ISO 1127		SMS 3008		DIN 11850-2	
								ØG/ØD [MM]		ØG/ØD [MM]		ØG/ØD [MM]		ØG/ØD [MM]	
DN08	1/4"	9	-	0.8	-	8	-	14/11.5 (1.25)	F	13.5/10.3 (1.6)	F	-	-	-	-
DN10	3/8"	9	-	0.8	-	8	-	17.2/12.6 (2.3)	F	17.2/14.0 (1.6)	F	12.0/10.0 (1.0)	F	13.0/10.0 (1.5)	F
DN15	1/2"	11	9	0.8	0.8	11	8	21.7/15 (3.35)	R/F	21.3/18.1 (1.6)	R/F	18.0/16.0 (1.0)	R/F	19.0/16.0 (1.5)	F
DN20	3/4"	12	11	1.3	0.8	28	11	27.2/20.5 (3.35)	R/F	26.9/23.7 (1.6)	R/F	25.0/22.6 (1.2)	R/F	23.0/20.0 (1.5)	F
DN25	1"	19	12	2.0	1.3	50	28	34/25.7 (4.15)	R/F	33.7/29.7 (2.0)	R/F	32.0/29.6 (1.2)	R	29.0/26.0 (1.5)	F
DN32	1 1/4"	28	19	2.8	2.0	71	50	42.7/34.4 (4.15)	R/F	42.4/38.4 (2.0)	R/F	33.7/31.3 (1.2)	R	35.0/32.0 (1.5)	F
DN40	1 1/2"	37	28	4.3	2.8	102	71	48.6/40.3 (4.15)	R/F	48.3/44.3 (2.0)	R/F	38.0/35.6 (1.2)	R	41.0/38.0 (1.5)	F
DN50	2"	52	37	5.7	4.4	205	102	60.5/51.3 (4.6)	R/F	60.3/55.1 (2.6)	R/F	51.0/48.6 (1.2)	R	53.0/50.0 (1.5)	F
DN65	2 1/2"	68	52	11.4	6.1	275	205	76.3/67.1 (4.6)	R/F	76.1/70.9 (2.6)	R/F	63.5/60.3 (1.6)	R	70.0/66.0 (2.0)	F
DN80	3"	100	68	15.1	13.0	500	275	88.9/80 (4.45)	R/F	88.9/83.7 (2.6)	R/F	76.1/72.9 (1.6)	R	85.0/81.0 (2.0)	F
DN100	4"	112	100	24.3	16.3	867	500	116/103.1 (6.45)	R/F	114.3/109.1 (2.6)	R/F	101.6/97.6 (2.0)	R	104.0/100.0 (2.0)	F

\*) Torque figures include 30% safety factor. (TEST: 0bar diff. pressure, ambient temperature, non-lubricating)

Torque is based on standard seats packing PTFE with 25% carbon.

Torque on request: Seat packing PTFE TFM1600, PEEK, PTFE with 50% SS, DELRIN, PTFE with 15% glass fibre.

\*\*) Weight is based on flower shaped (DN50-100F) welding ends ISO 1127.

## PRESSURE/TEMPERATURE

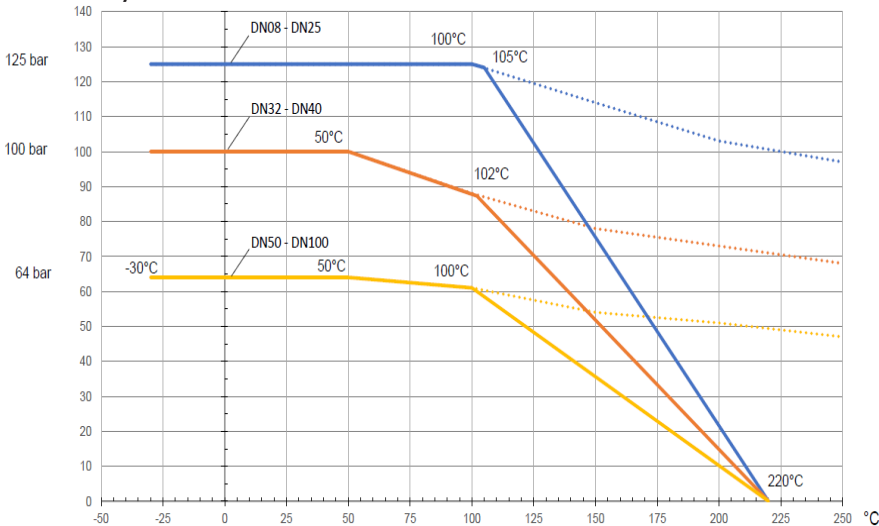

### Helium leakage test

performed by German laboratory

Two tests have been executed with vacuum inside valve – spray with helium on the outside:

- 1 x closed position, tightness on seats (flow direction)
- 1 x half open position, tightness on stem and body sealings

Test result leakage rate:  $10^{-7}$  mbar \* l \* s<sup>-1</sup>

Further details can be seen on the test certificate.