

# DRS 60: Incremental Encoders with Zero-Pulse-Teach



- Long LED lifetime as a result of automatic light regulation
- Maximum reliability as a result of opto-ASICs with Chip-on-Board technology
- Interchangeable collets for hollow shaft diameters from 6 to 15 mm and 1/4, 3/8, 1/2 inch.

Whether with face mount flange, servo flange, blind or through hollow shaft with connector or cable outlet, TTL or HTL interface - DRS 60 encoders will meet virtually any application profile.

 <p><b>Number of lines 1 up to 8192</b></p>
<p><b>Incremental Encoder</b></p>

**CoreTech**<sup>®</sup>  
by **SICK** | **STEGMANN**

**C**oreTech technology permits tailor-made solutions for every application, due to its modular design. DRS 60 incremental encoders are available with any desired number of lines between 1 and 8,192. Further highlights of this generation of encoders:

- Simple zero-pulse-teach by pressing a button located under a cap on the rear of the encoder
- Excellent price/performance ratio

Thanks to this wide variety of products, there are numerous possible uses, for example in:

- machine tools
- textile machines
- woodworking machines
- packaging machines

**Number of lines**  
**1 up to 8192**

Incremental Encoder

- Connector or cable outlet
- Protection class up to IP 66
- Electrical Interfaces  
TTL and HTL
- Zero-Pulse-Teach via pressing a button

## Dimensional drawing face mount flange radial

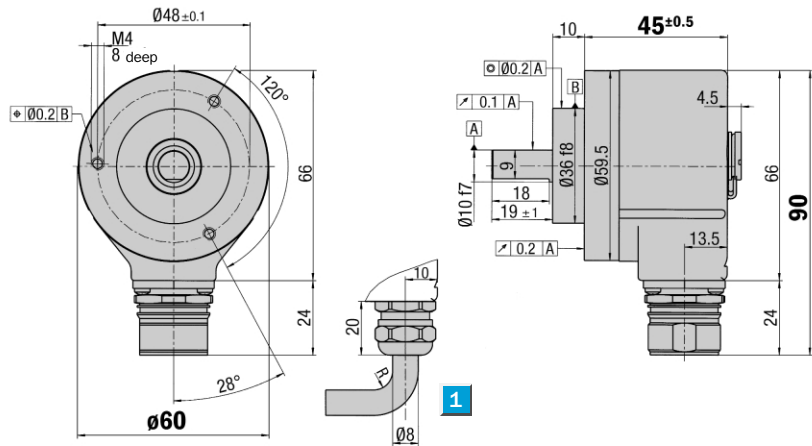

**1** R = bending radius min. 40 mm      General tolerances according to DIN ISO 2768-mk

## Dimensional drawing face mount flange axial

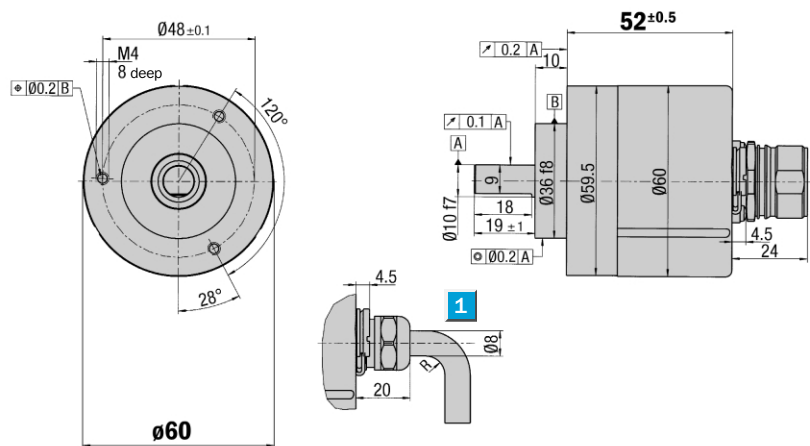

**1** R = bending radius min. 40 mm      General tolerances according to DIN ISO 2768-mk



## PIN- and wire allocation

PIN	Signal	Wire colour (Cable outlet)	Explanation
1	$\bar{B}$	black	Signal line
2	Sense +	grey	Connected internally to Us
3	Z	lilac	Signal line
4	$\bar{Z}$	yellow	Signal line
5	A	white	Signal line
6	$\bar{A}$	brown	Signal line
7	N.C.		Not connected
8	B	pink	Signal line
9	Screen		Housing potential
10	GND	blue	Zero volt connected to the encoder
11	Sense -	green	Connected internally to GND
12	Us	red	Supply voltage to the encoder <sup>1)</sup>



### Accessories

- Connection systems
- Mounting systems

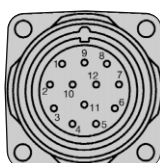

View of the connector M 23 fitted to the encoder body

<sup>1)</sup> Potential free to housing

Technical Data		DRS 60 face mount flange	Flange type											
			face m.											
<b>Solid shaft</b>	10 mm													
<b>Number of lines per revolution</b>	00001 up to 08192 see order info													
<b>Electrical Interface</b>	TTL / RS 422, 6-channel													
	HTL / push-pull, 6-channel													
<b>Mass <sup>1)</sup></b>	approx. 0.3 kg													
<b>Moment of inertia of the rotor</b>	54 gcm <sup>2</sup>													
<b>Measuring step</b>	90° / number of lines													
<b>Reference signal</b>														
Number	1													
Position <sup>2)</sup>	90° or 180°													
<b>Error limits</b>														
binary number of lines	0.035°													
non-binary number of lines	0.046°													
<b>Measuring step deviation</b>														
binary number of lines	0.005°													
non-binary number of lines	0.016°													
<b>Max. output frequency</b>														
TTL	820 kHz													
HTL	200 kHz													
<b>Operating torque max.</b>														
with shaft seal	6,000 min <sup>-1</sup>													
without shaft seal <sup>3)</sup>	10,000 min <sup>-1</sup>													
<b>Max. angular acceleration</b>	5 x 10 <sup>5</sup> rad/s <sup>2</sup>													
<b>Operating torque</b>	typ. 0.3 Ncm													
<b>Start up torque</b>	typ. 0.4 Ncm													
<b>Permissible shaft loading</b>														
Radial	20 N													
Axial	10 N													
<b>Bearing lifetime</b>	3.6 x 10 <sup>9</sup> Revolutions													
<b>Working temperature range</b>	- 20° ... + 85° C													
<b>Storage temperature range</b>	- 40° ... + 100° C													
<b>Permissible relative humidity <sup>4)</sup></b>	90 %													
<b>EMC <sup>5)</sup></b>														
<b>Resistance</b>														
to shocks <sup>6)</sup>	50 / 11 g/ms													
to vibration <sup>7)</sup>	20 / 10 ... 150 g/Hz													
<b>Protection class IEC 60529</b>														
Connector outlet <sup>8)</sup>	IP 65													
Cable outlet	IP 66													
<b>Operating voltage range</b>														
Load current TTL / RS 422, 4.5 ... 5.5V	max. 20 mA													
TTL / RS 422, 10 ... 32V	max. 20 mA													
HTL / push-pull, 10 ... 32V	max. 60 mA													
<b>No-load operating current</b>														
at 10 ... 32 V	typ. 100 mA													
at 5 V	typ. 120 mA													
<b>Operation of zero-set <sup>9)</sup></b>	≥ 100 ms													
<b>Initialisation time after power on</b>	40 ms													

<sup>1)</sup> Concerning encoder with connector

<sup>2)</sup> electrical, logically linked to A and B

<sup>3)</sup> In case, that shaft seal has been removed by customer

<sup>4)</sup> Condensation not permitted

<sup>5)</sup> to DIN EN 61000-6-4 and DIN EN 61000-6-1

<sup>6)</sup> to DIN IEC 68 part 2-27

<sup>7)</sup> to DIN IEC 68 part 2-6

<sup>8)</sup> With mating connector fitted

<sup>9)</sup> only with shaft stationary

 **Number of lines**  
**1 up to 8192**

Incremental Encoder

- Connector or cable outlet
- Protection class up to IP 66
- Electrical Interfaces  
TTL and HTL
- Zero-Pulse-Teach via pressing a button



### Incremental pulse diagram

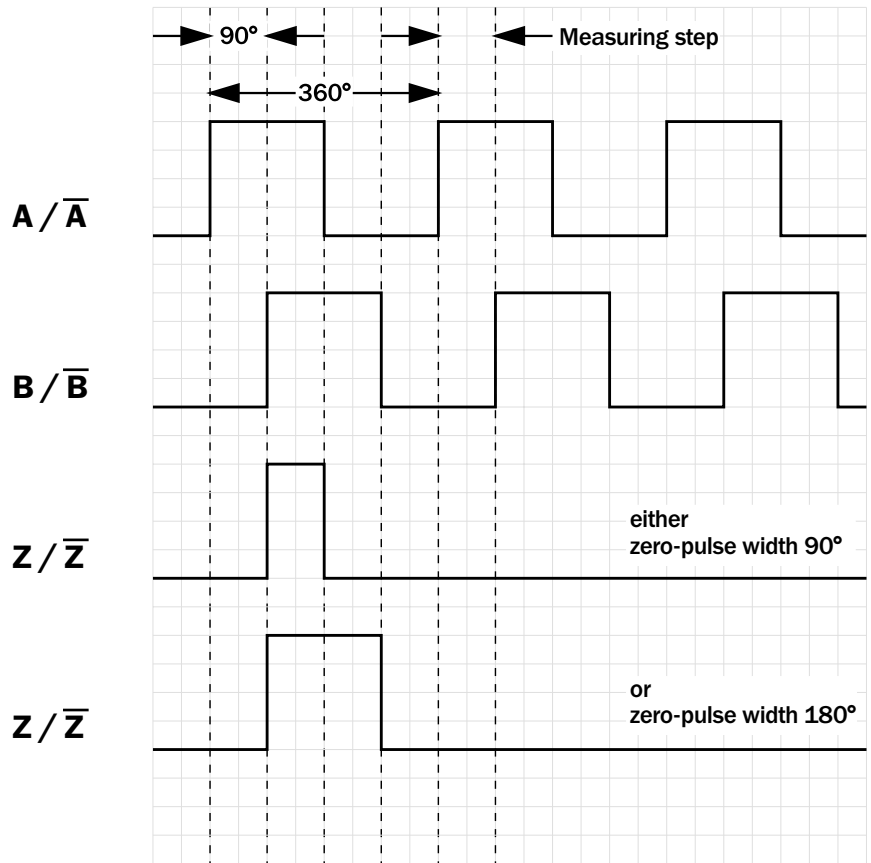

### Electrical Interface

Supply voltage	4.5 ... 5.5 V	10 ... 32 V	10 ... 32 V
Interfaces/drivers	TTL (RS 422)	TTL (RS 422)	HTL (push-pull)

### Connection type

- Cable radial   
  Cable axial   
  Connector radial   
  Connector axial

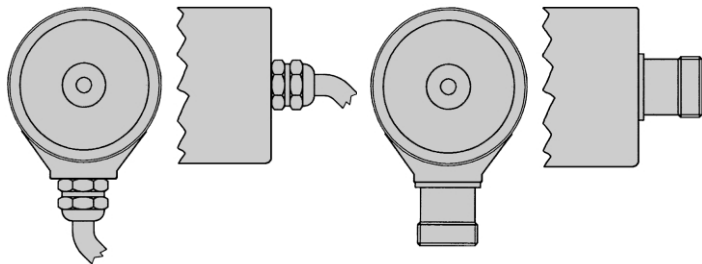

<b>Accessories</b>
Connection systems
Mounting systems



**Order Information**

**Incremental Encoder DRS 60, face mount flange, solid shaft**

Point 1	Point 2	Point 3	Point 4	Point 5	Point 6	Point 7	Point 8	Point 9	Point 10	Point 11	Point 12	Point 13	Point 14
<b>D</b>	<b>R</b>	<b>S</b>	<b>6</b>	<b>0</b>	<b>-</b>								

Electrical Interface	Mechanical Interface	Connection type	Number of lines
4.5 ... 5.5 V, TTL/RS 422 Zero-pulse width 90° = <b>A</b>	Face mount flange, solid shaft 10 mm = <b>4</b>	Connector M23, 12 pin, radial = <b>A</b>	Each number of lines from 00001 up to 08192 possible. Always 5 characters in clear text
4.5 ... 5.5 V, TTL/RS 422 Zero-pulse width 180° = <b>B</b>		Connector M23, 12 pin, axial = <b>B</b>	
10 ... 32 V, TTL/RS 422 Zero-pulse width 90° = <b>C</b>		Cable 11 core, radial 1.5 m = <b>K</b>	
10 ... 32 V, TTL/RS 422 Zero-pulse width 180° = <b>D</b>		Cable 11 core, radial 3 m = <b>L</b>	
10 ... 32 V, HTL/push-pull Zero-pulse width 90° = <b>E</b>		Cable 11 core, radial 5 m = <b>M</b>	
10 ... 32 V, HTL/push-pull Zero-pulse width 180° = <b>F</b>		Cable 11 core, axial 1.5 m = <b>R</b>	
		Cable 11 core, axial 3 m = <b>S</b>	
		Cable 11 core, axial 5 m = <b>T</b>	

**Order example Incremental Encoder DRS 60**

**4.5 ... 5.5 Volt, TTL/RS 422 zero-pulse width 90°; face mount flange; connector M23, 12 pin, radial; number of lines: 360**

Point 1	Point 2	Point 3	Point 4	Point 5	Point 6	Point 7	Point 8	Point 9	Point 10	Point 11	Point 12	Point 13	Point 14
<b>D</b>	<b>R</b>	<b>S</b>	<b>6</b>	<b>0</b>	<b>-</b>	<b>A</b>	<b>4</b>	<b>A</b>	<b>0</b>	<b>0</b>	<b>3</b>	<b>6</b>	<b>0</b>

**Please enter your individual encoder here**

Point 1	Point 2	Point 3	Point 4	Point 5	Point 6	Point 7	Point 8	Point 9	Point 10	Point 11	Point 12	Point 13	Point 14
<b>D</b>	<b>R</b>	<b>S</b>	<b>6</b>	<b>0</b>	<b>-</b>								

Point 1	Point 2	Point 3	Point 4	Point 5	Point 6	Point 7	Point 8	Point 9	Point 10	Point 11	Point 12	Point 13	Point 14
<b>D</b>	<b>R</b>	<b>S</b>	<b>6</b>	<b>0</b>	<b>-</b>								

Point 1	Point 2	Point 3	Point 4	Point 5	Point 6	Point 7	Point 8	Point 9	Point 10	Point 11	Point 12	Point 13	Point 14
<b>D</b>	<b>R</b>	<b>S</b>	<b>6</b>	<b>0</b>	<b>-</b>								

**Number of lines**  
**1 up to 8192**

Incremental Encoder

- Connector or cable outlet
- Protection class up to IP 66
- Electrical Interfaces  
TTL and HTL
- Zero-Pulse-Teach via pressing a button

### Dimensional drawing servo flange radial

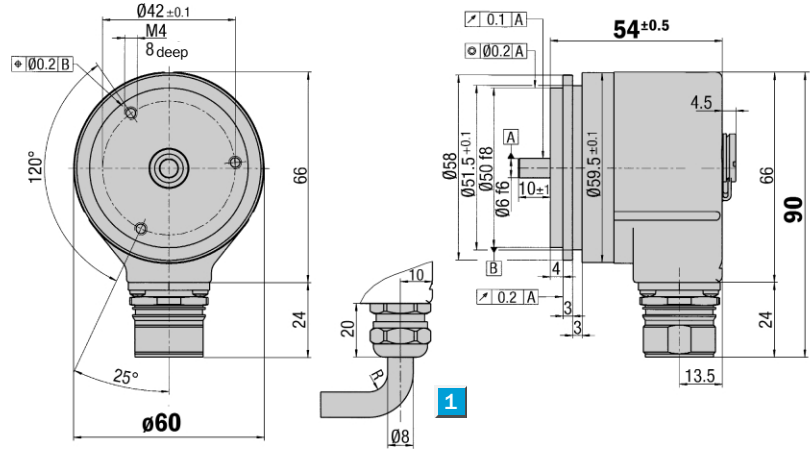

1 R = bending radius min. 40 mm

General tolerances according to DIN ISO 2768-mk

### Dimensional drawing servo flange axial

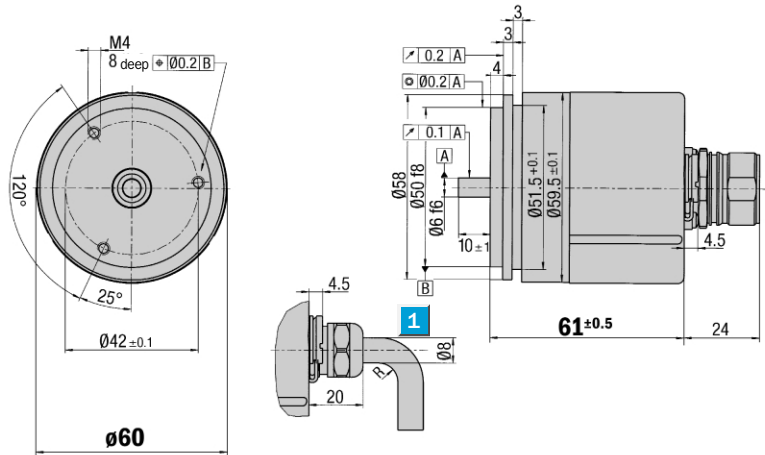

1 R = bending radius min. 40 mm

General tolerances according to DIN ISO 2768-mk

### PIN- and wire allocation

PIN	Signal	Wire colour (Cable outlet)	Explanation
1	$\bar{B}$	black	Signal line
2	Sense +	grey	Connected internally to Us
3	Z	lilac	Signal line
4	$\bar{Z}$	yellow	Signal line
5	A	white	Signal line
6	$\bar{A}$	brown	Signal line
7	N.C.		Not connected
8	B	pink	Signal line
9	Screen		Housing potential
10	GND	blue	Zero volt connected to the encoder
11	Sense -	green	Connected internally to GND
12	Us	red	Supply voltage to the encoder <sup>1)</sup>

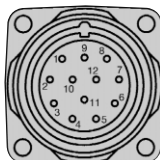

View of the connector M 23 fitted to the encoder body

<sup>1)</sup> Potential free to housing



Accessories
Connection systems
Mounting systems

Technical Data		DRS 60 servo flange	Flange type											
			servo											
<b>Solid shaft</b>	6 mm													
<b>Number of lines per revolution</b>	00001 up to 08192 see order info													
<b>Electrical Interface</b>	TTL / RS 422, 6-channel													
	HTL / push-pull, 6-channel													
<b>Mass <sup>1)</sup></b>	approx. 0.3 kg													
<b>Moment of inertia of the rotor</b>	48 gcm <sup>2</sup>													
<b>Measuring step</b>	90° / number of lines													
<b>Reference signal</b>														
Number	1													
Position <sup>2)</sup>	90° or 180°													
<b>Error limits</b>														
binary number of lines	0.035°													
non-binary number of lines	0.046°													
<b>Measuring step deviation</b>														
binary number of lines	0.005°													
non-binary number of lines	0.016°													
<b>Max. output frequency</b>														
TTL	820 kHz													
HTL	200 kHz													
<b>Operating torque max.</b>														
with shaft seal	6.000 min <sup>-1</sup>													
without shaft seal <sup>3)</sup>	10.000 min <sup>-1</sup>													
<b>Max. angular acceleration</b>	5 x 10 <sup>5</sup> rad/s <sup>2</sup>													
<b>Operating torque</b>	typ. 0.2 Ncm													
<b>Start up torque</b>	typ. 0.25 Ncm													
<b>Permissible shaft loading</b>														
Radial	20 N													
Axial	10 N													
<b>Bearing lifetime</b>	3.6 x 10 <sup>9</sup> Revolutions													
<b>Working temperature range</b>	- 20° ... + 85° C													
<b>Storage temperature range</b>	- 40° ... + 100° C													
<b>Permissible relative humidity <sup>4)</sup></b>	90 %													
<b>EMC <sup>5)</sup></b>														
<b>Resistance</b>														
to shocks <sup>6)</sup>	50 / 11 g/ms													
to vibration <sup>7)</sup>	20 / 10 ... 150 g/Hz													
<b>Protection class IEC 60529</b>														
Connector outlet <sup>8)</sup>	IP 65													
Cable outlet	IP 66													
<b>Operating voltage range</b>														
Load current TTL / RS 422, 4.5 ... 5.5V	max. 20 mA													
TTL / RS 422, 10 ... 32V	max. 20 mA													
HTL / push-pull, 10 ... 32V	max. 60 mA													
<b>No-load operating current</b>														
at 10 ... 32 V	typ. 100 mA													
at 5 V	typ. 120 mA													
<b>Operation of zero-set <sup>9)</sup></b>	≥ 100 ms													
<b>Initialisation time after power on</b>	40 ms													

<sup>1)</sup> Concerning encoder with connector

<sup>2)</sup> electrical, logically linked to A and B

<sup>3)</sup> In case, that shaft seal has been removed by customer

<sup>4)</sup> Condensation not permitted

<sup>5)</sup> to DIN EN 61000-6-4 and DIN EN 61000-6-1

<sup>6)</sup> to DIN IEC 68 part 2-27

<sup>7)</sup> to DIN IEC 68 part 2-6

<sup>8)</sup> With mating connector fitted

<sup>9)</sup> only with shaft stationary

**Number of lines**  
**1 up to 8192**

Incremental Encoder

- Connector or cable outlet
- Protection class up to IP 66
- Electrical Interfaces  
TTL and HTL
- Zero-Pulse-Teach via pressing a button



### Incremental pulse diagram

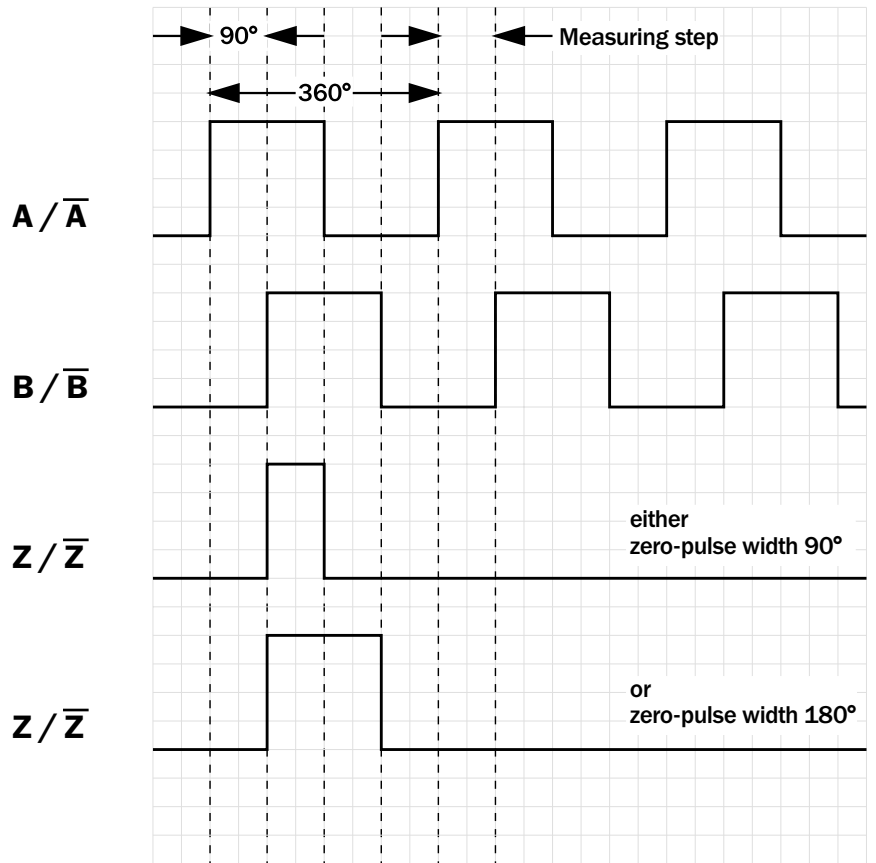

### Electrical Interface

Supply voltage	4.5 ... 5.5 V	10 ... 32 V	10 ... 32 V
Interfaces/drivers	TTL (RS 422)	TTL (RS 422)	HTL (push-pull)

### Connection type

Cable radial	Cable axial	Connector radial	Connector axial
--------------	-------------	------------------	-----------------

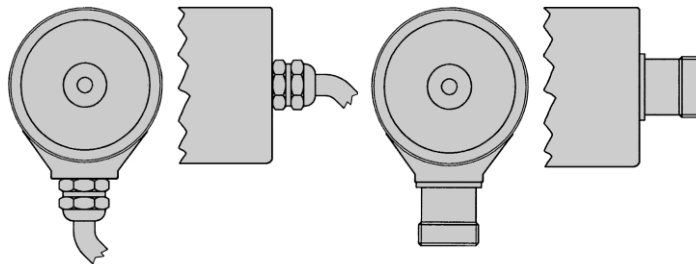

### Accessories

- Connection systems
- Mounting systems





**Order information**

**Incremental Encoder DRS 60, servo flange, solid shaft**

Point 1	Point 2	Point 3	Point 4	Point 5	Point 6	Point 7	Point 8	Point 9	Point 10	Point 11	Point 12	Point 13	Point 14
<b>D</b>	<b>R</b>	<b>S</b>	<b>6</b>	<b>0</b>	<b>-</b>								

Electrical Interface	Mechanical Interface	Connection type	Number of lines
4.5 ... 5.5 V, TTL/RS 422 Zero-pulse width 90° = <b>A</b>	Servo flange, solid shaft 6 mm = <b>1</b>	Connector M23, 12 pin, radial = <b>A</b>	Each number of lines from 00001 up to 08192 possible. Always 5 characters in clear text
4.5 ... 5.5 V, TTL/RS 422 Zero-pulse width 180° = <b>B</b>		Connector M23, 12 pin, axial = <b>B</b>	
10 ... 32 V, TTL/RS 422 Zero-pulse width 90° = <b>C</b>		Cable 11 core, radial 1.5 m = <b>K</b>	
10 ... 32 V, TTL/RS 422 Zero-pulse width 180° = <b>D</b>		Cable 11 core, radial 3 m = <b>L</b>	
10 ... 32 V, HTL/push-pull Zero-pulse width 90° = <b>E</b>		Cable 11 core, radial 5 m = <b>M</b>	
10 ... 32 V, HTL/push-pull Zero-pulse width 180° = <b>F</b>		Cable 11 core, axial 1.5 m = <b>R</b>	
		Cable 11 core, axial 3 m = <b>S</b>	
		Cable 11 core, axial 5 m = <b>T</b>	

**Order example Incremental Encoder DRS 60**

**4.5 ... 5.5 Volt, TTL/RS 422 zero-pulse width 90°; servo flange; connector M23, 12 pin, radial; number of lines: 360**

Point 1	Point 2	Point 3	Point 4	Point 5	Point 6	Point 7	Point 8	Point 9	Point 10	Point 11	Point 12	Point 13	Point 14
<b>D</b>	<b>R</b>	<b>S</b>	<b>6</b>	<b>0</b>	<b>-</b>	<b>A</b>	<b>1</b>	<b>A</b>	<b>0</b>	<b>0</b>	<b>3</b>	<b>6</b>	<b>0</b>

**Please enter your individual encoder here**

Point 1	Point 2	Point 3	Point 4	Point 5	Point 6	Point 7	Point 8	Point 9	Point 10	Point 11	Point 12	Point 13	Point 14
<b>D</b>	<b>R</b>	<b>S</b>	<b>6</b>	<b>0</b>	<b>-</b>								

Point 1	Point 2	Point 3	Point 4	Point 5	Point 6	Point 7	Point 8	Point 9	Point 10	Point 11	Point 12	Point 13	Point 14
<b>D</b>	<b>R</b>	<b>S</b>	<b>6</b>	<b>0</b>	<b>-</b>								

Point 1	Point 2	Point 3	Point 4	Point 5	Point 6	Point 7	Point 8	Point 9	Point 10	Point 11	Point 12	Point 13	Point 14
<b>D</b>	<b>R</b>	<b>S</b>	<b>6</b>	<b>0</b>	<b>-</b>								

**Number of lines**  
**1 up to 8192**

Incremental Encoder

- Connector or cable outlet
- Protection class up to IP 66
- Electrical Interfaces  
TTL and HTL
- Zero-Pulse-Teach via pressing a button

## Dimensional drawing blind hollow shaft radial

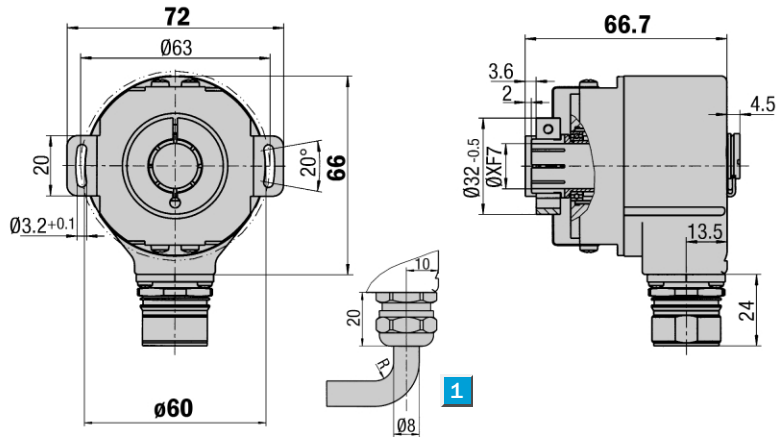

1 R = bending radius min. 40 mm

General tolerances according to DIN ISO 2768-mk

## Dimensional drawing blind hollow shaft axial

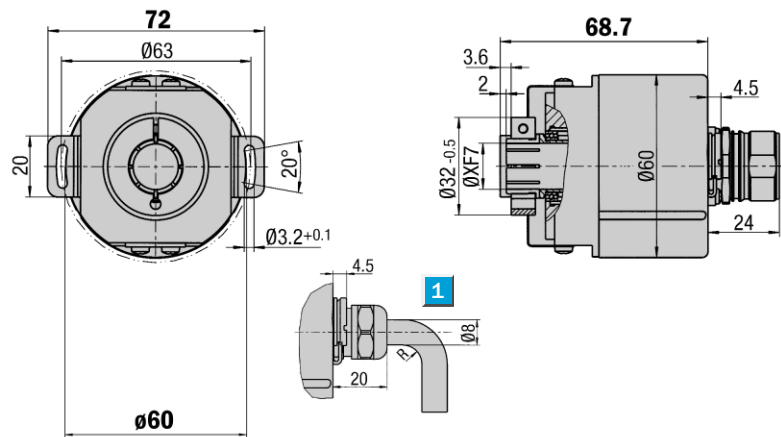

1 R = bending radius min. 40 mm

General tolerances according to DIN ISO 2768-mk

## PIN- and wire allocation

PIN	Signal	Wire colour (Cable outlet)	Explanation
1	$\bar{B}$	black	Signal line
2	Sense +	grey	Connected internally to Us
3	Z	lilac	Signal line
4	$\bar{Z}$	yellow	Signal line
5	A	white	Signal line
6	$\bar{A}$	brown	Signal line
7	N.C.		Not connected
8	B	pink	Signal line
9	Screen		Housing potential
10	GND	blue	Zero volt connected to the encoder
11	Sense -	green	Connected internally to GND
12	Us	red	Supply voltage to the encoder <sup>1)</sup>

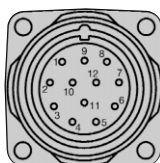

View of the connector M 23 fitted to the encoder body

<sup>1)</sup> Potential free to housing



### Accessories

- Connection systems
- Mounting systems
- Collets

Technical Data		DRS 60 blind hollow shaft										Flange type									
		blind																			
<b>Hollow shaft diameter</b>	6, 8, 10, 12, 15 mm, 1/4", 3/8", 1/2"																				
<b>Number of lines per revolution</b>	00001 up to 08192 see order info																				
<b>Electrical Interface</b>	TTL / RS 422, 6-channel																				
	HTL / push-pull, 6-channel																				
<b>Mass <sup>4)</sup></b>	approx. 0.3 kg																				
<b>Moment of inertia of the rotor</b>	see Fig. 1																				
<b>Measuring step</b>	90° / number of lines																				
<b>Reference signal</b>																					
Number	1																				
Position <sup>2)</sup>	90° or 180°																				
<b>Error limits</b>																					
binary number of lines	0.035°																				
non-binary number of lines	0.046°																				
<b>Measuring step deviation</b>																					
binary number of lines	0.005°																				
non-binary number of lines	0.016°																				
<b>Max. output frequency</b>																					
TTL	820 kHz																				
HTL	200 kHz																				
<b>Operating torque max.</b>	3.000 min <sup>-1</sup>																				
<b>Max. angular acceleration</b>	5 x 10 <sup>5</sup> rad/s <sup>2</sup>																				
<b>Operating torque</b>	typ. 0.4 Ncm																				
<b>Start up torque</b>	typ. 0.6 Ncm																				
<b>Permissible movement of the drive element</b>																					
Radial static / dynamic movement	± 0.3 / ± 0.1 mm																				
Axial static / dynamic movement	± 0.5 / ± 0.2 mm																				
<b>Bearing lifetime</b>	3.6 x 10 <sup>9</sup> Revolutions																				
<b>Working temperature range</b>	- 20° ... + 85° C																				
<b>Storage temperature range</b>	- 40° ... + 100° C																				
<b>Permissible relative humidity <sup>4)</sup></b>	90 %																				
<b>EMC <sup>4)</sup></b>																					
<b>Resistance</b>																					
to shocks <sup>6)</sup>	50 / 11 g/ms																				
to vibration <sup>7)</sup>	20 / 10 ... 150 g/Hz																				
<b>Protection class IEC 60529</b>																					
Connector outlet <sup>7)</sup>	IP 65																				
Cable outlet	IP 66																				
<b>Operating voltage range</b>																					
Load current TTL / RS 422, 4.5 ... 5.5V	max. 20 mA																				
	TTL / RS 422, 10 ... 32V	max. 20 mA																			
	HTL / push-pull, 10 ... 32V	max. 60 mA																			
<b>No-load operating current</b>																					
at 10 ... 32 V	typ. 100 mA																				
at 5 V	typ. 120 mA																				
<b>Operation of zero-set <sup>9)</sup></b>	≥ 100 ms																				
<b>Initialisation time after power on</b>	40 ms																				

<sup>1)</sup> Concerning encoder with connector  
<sup>2)</sup> electrical, logically linked to A and B  
<sup>3)</sup> Condensation not permitted

<sup>4)</sup> to DIN EN 61000-6-4 and DIN EN 61000-6-1  
<sup>5)</sup> to DIN IEC 68 part 2-27  
<sup>6)</sup> to DIN IEC 68 part 2-6  
<sup>7)</sup> With mating connector fitted  
<sup>8)</sup> only with shaft stationary

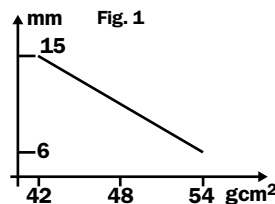

 **Number of lines**  
**1 up to 8192**

Incremental Encoder

- Connector or cable outlet
- Protection class up to IP 66
- Electrical Interfaces  
TTL and HTL
- Zero-Pulse-Teach via pressing a button



### Incremental pulse diagram

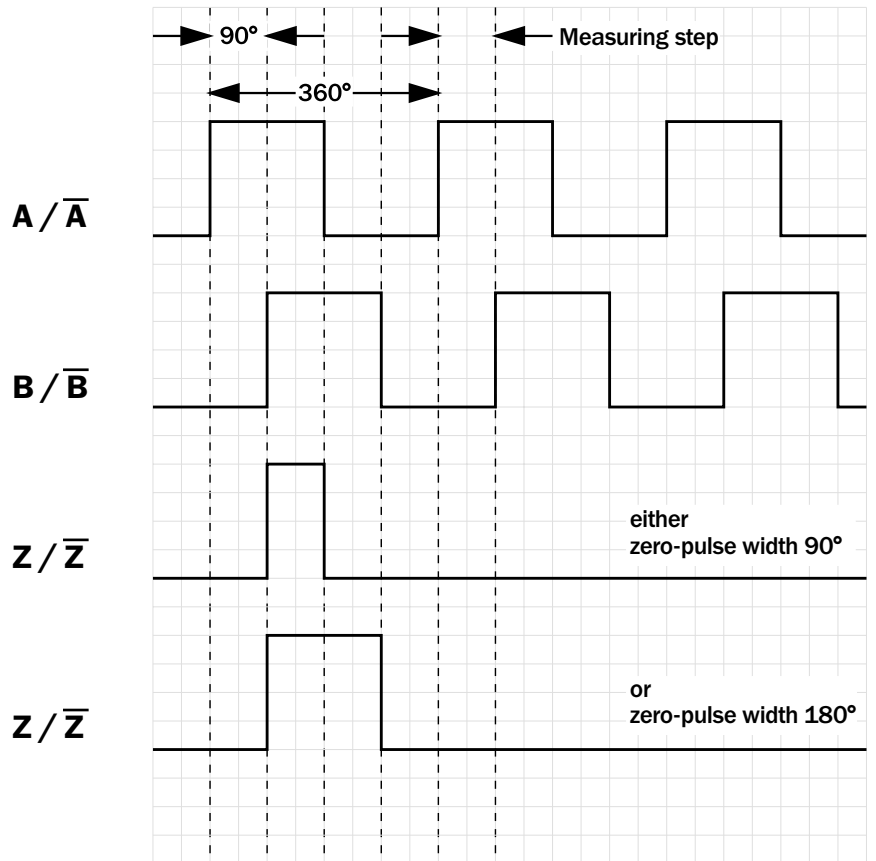

### Electrical Interface

Supply voltage	4.5 ... 5.5 V	10 ... 32 V	10 ... 32 V
Interfaces/drivers	TTL (RS 422)	TTL (RS 422)	HTL (push-pull)

### Connection type

Cable radial	Cable axial	Connector radial	Connector axial
--------------	-------------	------------------	-----------------

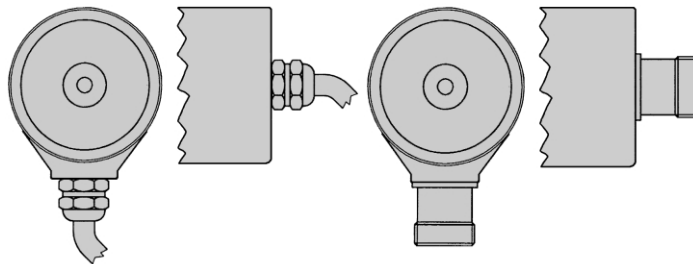

<b>Accessories</b>
Connection systems
Mounting systems
Collets



**Order information**

**Incremental Encoder DRS 60, blind hollow shaft**

Point 1	Point 2	Point 3	Point 4	Point 5	Point 6	Point 7	Point 8	Point 9	Point 10	Point 11	Point 12	Point 13	Point 14
<b>D</b>	<b>R</b>	<b>S</b>	<b>6</b>	<b>0</b>	<b>-</b>								

Electrical Interface	Mechanical Interface	Connection type	Number of lines
4.5 ... 5.5 V, TTL/RS 422 Zero-pulse width 90° = <b>A</b>	Blind hollow shaft <sup>1)</sup> = <b>A</b>	Connector M23, 12 pin, radial = <b>A</b>	Each number of lines from 00001 up to 08192 possible. Always 5 characters in clear text
4.5 ... 5.5 V, TTL/RS 422 Zero-pulse width 180° = <b>B</b>	<sup>1)</sup> Collets for 6, 8, 10, 12 mm and 1/4", 3/8" and 1/2" as accessories, separate order item (see below). For 15mm shaft diameter, collet is not needed.	Connector M23, 12 pin, axial = <b>B</b>	
10 ... 32 V, TTL/RS 422 Zero-pulse width 90° = <b>C</b>		Cable 11 core, radial 1.5 m = <b>K</b>	
10 ... 32 V, TTL/RS 422 Zero-pulse width 180° = <b>D</b>		Cable 11 core, radial 3 m = <b>L</b>	
10 ... 32 V, HTL/push-pull Zero-pulse width 90° = <b>E</b>		Cable 11 core, radial 5 m = <b>M</b>	
10 ... 32 V, HTL/push-pull Zero-pulse width 180° = <b>F</b>		Cable 11 core, axial 1.5 m = <b>R</b>	
		Cable 11 core, axial 3 m = <b>S</b>	
		Cable 11 core, axial 5 m = <b>T</b>	

**Order example Incremental Encoder DRS 60**

**4.5 ... 5.5 Volt, TTL/RS 422 zero-pulse width 90°; blind hollow shaft; connector M23, 12 pin, radial; number of lines: 360**

Point 1	Point 2	Point 3	Point 4	Point 5	Point 6	Point 7	Point 8	Point 9	Point 10	Point 11	Point 12	Point 13	Point 14
<b>D</b>	<b>R</b>	<b>S</b>	<b>6</b>	<b>0</b>	<b>-</b>	<b>A</b>	<b>A</b>	<b>A</b>	<b>0</b>	<b>0</b>	<b>3</b>	<b>6</b>	<b>0</b>

**Please enter your individual encoder here**

Point 1	Point 2	Point 3	Point 4	Point 5	Point 6	Point 7	Point 8	Point 9	Point 10	Point 11	Point 12	Point 13	Point 14
<b>D</b>	<b>R</b>	<b>S</b>	<b>6</b>	<b>0</b>	<b>-</b>								

Point 1	Point 2	Point 3	Point 4	Point 5	Point 6	Point 7	Point 8	Point 9	Point 10	Point 11	Point 12	Point 13	Point 14
<b>D</b>	<b>R</b>	<b>S</b>	<b>6</b>	<b>0</b>	<b>-</b>								

Point 1	Stelle 2	Point 3	Point 4	Point 5	Point 6	Point 7	Point 8	Point 9	Point 10	Point 11	Point 12	Point 13	Point 14
<b>D</b>	<b>R</b>	<b>S</b>	<b>6</b>	<b>0</b>	<b>-</b>								

**Blind hollow shaft collets**

Type	Part no.	Shaft diameter
SPZ-006-AD-A	2 029 174	6 mm
SPZ-1E4-AD-A	2 029 175	1/4"
SPZ-008-AD-A	2 029 176	8 mm
SPZ-3E8-AD-A	2 029 177	3/8"
SPZ-010-AD-A	2 029 178	10 mm
SPZ-012-AD-A	2 029 179	12 mm
SPZ-1E2-AD-A	2 029 180	1/2"

**Number of lines**  
**1 up to 8192**

Incremental Encoder

- Connector or cable outlet
- Protection class up to IP 64
- Electrical Interfaces  
TTL and HTL
- Zero-Pulse-Teach via pressing  
a button

## Dimensional drawing through hollow shaft radial

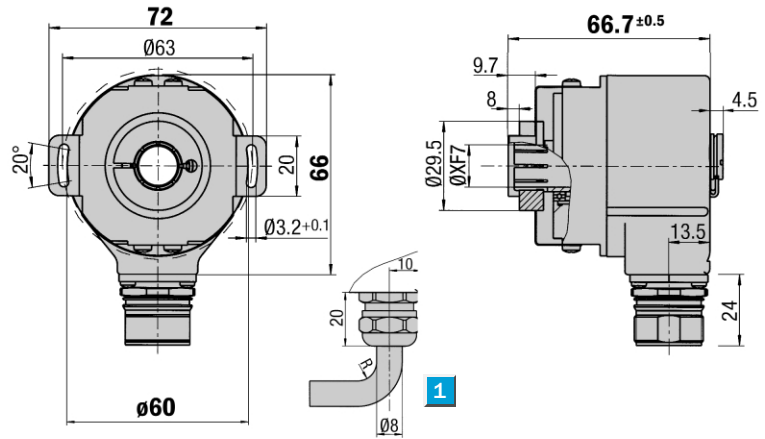

1 R = bending radius min. 40 mm

General tolerances according to DIN ISO 2768-mk



## PIN- and wire allocation

PIN	Signal	Wire colour (Cable outlet)	Explanation
1	$\bar{B}$	black	Signal line
2	Sense +	grey	Connected internally to Us
3	Z	lilac	Signal line
4	$\bar{Z}$	yellow	Signal line
5	A	white	Signal line
6	$\bar{A}$	brown	Signal line
7	N.C.		Not connected
8	B	pink	Signal line
9	Screen		Housing potential
10	GND	blue	Zero volt connected to the encoder
11	Sense -	green	Connected internally to GND
12	Us	red	Supply voltage to the encoder <sup>1)</sup>



### Accessories

- Connection systems
- Mounting systems
- Collets

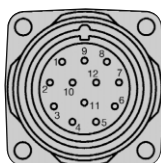

View of the connector M 23 fitted to the encoder body

<sup>1)</sup> Potential free to housing

Technical Data		DRS 60 through hollow shaft		Flange type									
				through									
<b>Hollow shaft diameter</b>		6, 8, 10, 12 mm sowie 1/4", 3/8", 1/2"											
<b>Number of lines per revolution</b>		00001 up to 08192 see order info											
<b>Electrical Interface</b>		TTL / RS 422, 6-channel											
		HTL / push-pull, 6-channel											
<b>Mass <sup>4)</sup></b>		approx. 0.3 kg											
<b>Moment of inertia of the rotor</b>		see Fig. 1											
<b>Measuring step</b>		90° / number of lines											
<b>Reference signal</b>													
Number		1											
Position <sup>2)</sup>		90° or 180°											
<b>Error limits</b>													
binary number of lines		0.035°											
non-binary number of lines		0.046°											
<b>Measuring step deviation</b>													
binary number of lines		0.005°											
non-binary number of lines		0.016°											
<b>Max. output frequency</b>													
TTL		820 kHz											
HTL		200 kHz											
<b>Operating torque max.</b>		3.000 min <sup>-1</sup>											
<b>Max. angular acceleration</b>		5 x 10 <sup>5</sup> rad/s <sup>2</sup>											
<b>Operating torque</b>		typ. 1.6 Ncm											
<b>Start up torque</b>		typ. 2.2 Ncm											
<b>Permissible movement of the drive element</b>													
Radial static / dynamic movement		± 0.3 / ± 0.1 mm											
Axial static / dynamic movement		± 0.5 / ± 0.2 mm											
<b>Bearing lifetime</b>		3.6 x 10 <sup>9</sup> Revolutions											
<b>Working temperature range</b>		- 20° ... + 85° C											
<b>Storage temperature range</b>		- 40° ... + 100° C											
<b>Permissible relative humidity <sup>4)</sup></b>		90 %											
<b>EMC <sup>4)</sup></b>													
<b>Resistance</b>													
to shocks <sup>6)</sup>		50 / 11 g/ms											
to vibration <sup>7)</sup>		20 / 10 ... 150 g/Hz											
<b>Protection class IEC 60529</b>													
Connector outlet <sup>7)</sup>		IP 64											
Cable outlet		IP 64											
<b>Operating voltage range</b>													
Load current TTL / RS 422, 4.5 ... 5.5V		max. 20 mA											
		TTL / RS 422, 10 ... 32V											
		HTL / push-pull, 10 ... 32V											
		max. 60 mA											
<b>No-load operating current</b>													
at 10 ... 32 V		typ. 100 mA											
at 5 V		typ. 120 mA											
<b>Operation of zero-set <sup>9)</sup></b>		≥ 100 ms											
<b>Initialisation time after power on</b>		40 ms											

<sup>1)</sup> Concerning encoder with connector  
<sup>2)</sup> electrical, logically linked to A and B  
<sup>3)</sup> Condensation not permitted

<sup>4)</sup> to DIN EN 61000-6-4 and DIN EN 61000-6-1  
<sup>5)</sup> to DIN IEC 68 part 2-27  
<sup>6)</sup> to DIN IEC 68 part 2-6  
<sup>7)</sup> With mating connector fitted  
<sup>8)</sup> only with shaft stationary

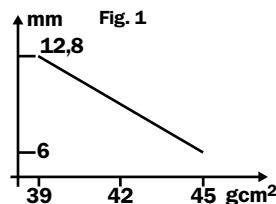

 **Number of lines**  
**1 up to 8192**

Incremental Encoder

- Connector or cable outlet
- Protection class up to IP 64
- Electrical Interfaces  
TTL and HTL
- Zero-Pulse-Teach via pressing  
a button



## Incremental pulse diagram

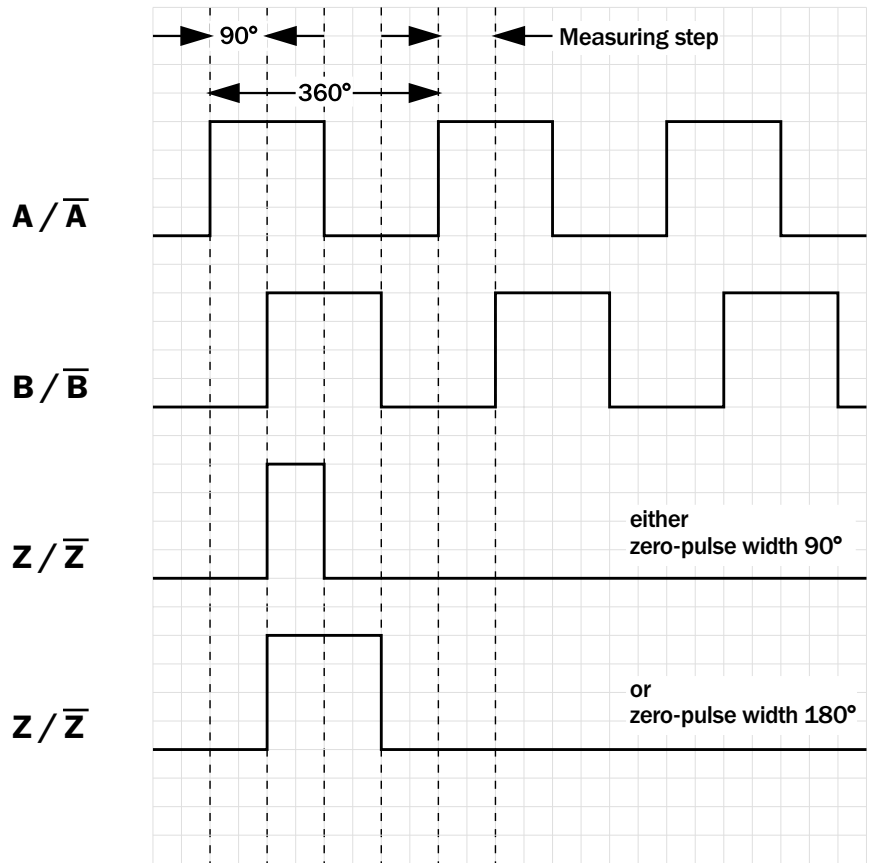

## Electrical Interface

Supply voltage	4.5 ... 5.5 V	10 ... 32 V	10 ... 32 V
Interfaces/drivers	TTL (RS 422)	TTL (RS 422)	HTL (push-pull)

## Connection type

Cable radial

Connector radial

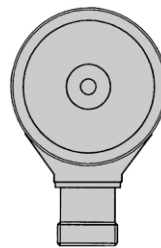
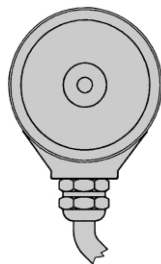

<b>Accessories</b>
Connection systems
Mounting systems
Collets



**Order information**

**Incremental Encoder DRS 60, through hollow shaft**

Point 1	Point 2	Point 3	Point 4	Point 5	Point 6	Point 7	Point	Point 9	Point 10	Point 11	Point 12	Point 13	Point 14
<b>D</b>	<b>R</b>	<b>S</b>	<b>6</b>	<b>0</b>	<b>-</b>								

<p><b>Electrical Interface</b></p> <p>4.5 ... 5.5 V, TTL/RS 422 Zero-pulse width 90° = <b>A</b></p> <p>4.5 ... 5.5 V, TTL/RS 422 Zero-pulse width 180° = <b>B</b></p> <p>10 ... 32 V, TTL/RS 422 Zero-pulse width 90° = <b>C</b></p> <p>10 ... 32 V, TTL/RS 422 Zero-pulse width 180° = <b>D</b></p> <p>10 ... 32 V, HTL/push-pull Zero-pulse width 90° = <b>E</b></p> <p>10 ... 32 V, HTL/push-pull Zero-pulse width 180° = <b>F</b></p>	<p><b>Mechanical Interface</b></p> <p>Through hollow shaft<sup>1)</sup> = <b>D</b></p> <p><sup>1)</sup> Collets for 6, 8, 10, 12 mm and 1/4", 3/8" and 1/2" as accessories, separate order item (see below).</p>	<p><b>Connection type</b></p> <p>Connector M23, 12 pin, radial = <b>A</b></p> <p>Cable 11 core, radial 1.5 m = <b>K</b></p> <p>Cable 11 core, radial 3 m = <b>L</b></p> <p>Cable 11 core, radial 5 m = <b>M</b></p>	<p><b>Number of lines</b></p> <p>Each number of lines from 00001 up to 08192 possible.</p> <p>Always 5 characters in clear text</p>
---	--	---	---

**Order example Incremental Encoder DRS 60**

**4.5 ... 5.5 Volt, TTL/RS 422 Zero-pulse width 90°; through hollow shaft; connector M23, 12 pin, radial; number of lines: 360**

Point 1	Point 2	Point 3	Point 4	Point 5	Point 6	Point 7	Point 8	Point 9	Point 10	Point 11	Point 12	Point 13	Point 14
<b>D</b>	<b>R</b>	<b>S</b>	<b>6</b>	<b>0</b>	<b>-</b>	<b>A</b>	<b>D</b>	<b>A</b>	<b>0</b>	<b>0</b>	<b>3</b>	<b>6</b>	<b>0</b>

**Please enter your individual encoder here**

Point 1	Point 2	Point 3	Point 4	Point 5	Point 6	Point 7	Point 8	Point 9	Point 10	Point 11	Point 12	Point 13	Point 14
<b>D</b>	<b>R</b>	<b>S</b>	<b>6</b>	<b>0</b>	<b>-</b>								

Point 1	Point 2	Point 3	Point 4	Point 5	Point 6	Point 7	Point 8	Point 9	Point 10	Point 11	Point 12	Point 13	Point 14
<b>D</b>	<b>R</b>	<b>S</b>	<b>6</b>	<b>0</b>	<b>-</b>								

Point 1	Point 2	Point 3	Point 4	Point 5	Point 6	Point 7	Point 8	Point 9	Point 10	Point 11	Point 12	Point 13	Point 14
<b>D</b>	<b>R</b>	<b>S</b>	<b>6</b>	<b>0</b>	<b>-</b>								

**Through hollow shaft collets**

Type	Part no.	Shaft diameter
SPZ-006-AD-D	2 029 192	6 mm
SPZ-1E4-AD-D	2 029 193	1/4"
SPZ-008-AD-D	2 029 194	8 mm
SPZ-3E8-AD-D	2 029 195	3/8"
SPZ-010-AD-D	2 029 196	10 mm
SPZ-012-AD-D	2 029 197	12 mm
SPZ-1E2-AD-D	2 029 198	1/2"

Dimensional drawings and order information

Screw-in system M 23, 12 pin

Cable connector M 23 female, 12-pin, straight, screened

Type	Part no.	Contacts
DOS-2312-G	6 027 538	12

Cable connector M 23, 12 pin, straight, screened

Type	Part no.	Contacts
STE-2312-G	6 027 537	12

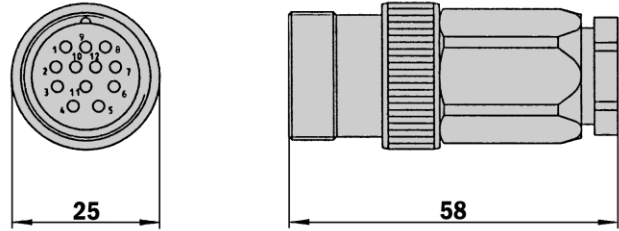
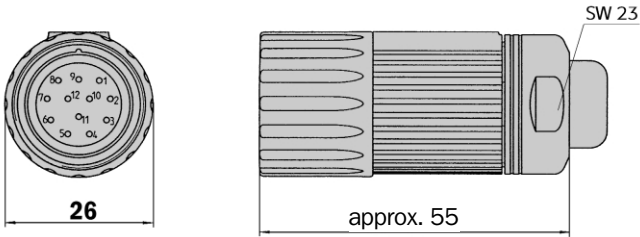

General tolerances according to DIN ISO 2768-mk

General tolerances according to DIN ISO 2768-mk

Connector M 23 female, 12-pin, straight, cable 12-cores, 4x2x0.25 + 2x0.5 + 2x0.14 mm<sup>2</sup> with screening, capable of being dragged, cable diameter 7,8 mm

Type	Part no.	Contacts	Cable length
DOL-2312-G1M5MA3	2 029 212	12	1.5 m
DOL-2312-G03MMA3	2 029 213	12	3.0 m
DOL-2312-G05MMA3	2 029 214	12	5.0 m
DOL-2312-G10MMA3	2 029 215	12	10.0 m
DOL-2312-G20MMA3	2 029 216	12	20.0 m
DOL-2312-G30MMA3	2 029 217	12	30.0 m

Cable 8 core, per meter, 4 x 2 x 0.15 mm<sup>2</sup> with screening, cable diameter 5.6 mm

Type	Part no.	Wires
LTG-2308-MW	6 027 529	8

Cable 11-core, per meter, 4 x 2 x 0.25 + 2 x 0.5 + 1 x 0.14 mm<sup>2</sup> with screening, cable diameter 7.5 mm

Type	Part no.	Wires
LTG-2411-MW	6 027 530	11

Cable 12 core, per meter, 4 x 2 x 0.25 + 2 x 0.5 + 2 x 0.14 mm<sup>2</sup> with screening, capable of being dragged, cable diameter 7.8 mm

Type	Part no.	Wires
LTG-2512-MW	6 027 531	12

**Dimensional drawings and order information**

**Couplings**

**Bellows coupling, max. shaft offset radial  $\pm 0.3$  mm, axial 0.4 mm, angle  $\pm 4$  degrees, torsion spring stiffness 120 Nm/rad, bellows of stainless steel, hubs of aluminium.**

Type	Part no.	Shaft diameter
KUP-0606-B	5 312 981	6 mm - 6 mm
KUP-0610-B	5 312 982	6 mm - 10 mm
KUP-1010-B	5 312 983	10 mm - 10 mm
KUP-1012-B	5 312 984	10 mm - 12 mm

cheese-head screw  
M2,5x8 DIN912 A2

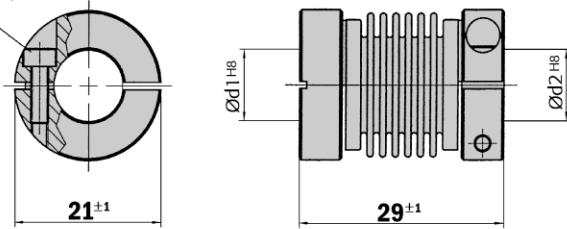

General tolerances according to DIN ISO 2768-mk

**Spring-disc coupling, max. shaft offset radial  $\pm 0.3$  mm, axial 0.4 mm, angle  $\pm 2.5$  degrees, torsion spring stiffness 50 Nm/rad, flange of aluminium, spring-discs of glass-fibre-reinforced plastic**

Type	Part no.	Shaft diameter
KUP-0610-F	5 312 985	6 mm - 10 mm
KUP-1010-F	5 312 986	10 mm - 10 mm

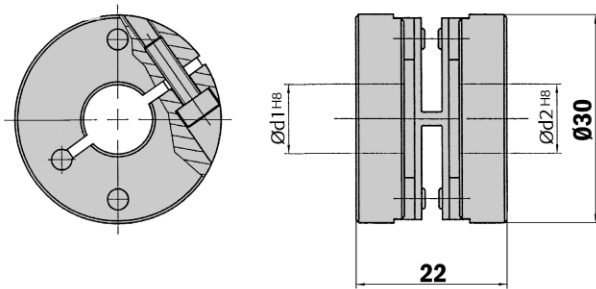

General tolerances according to DIN ISO 2768-mk

## Dimensional drawings and order information

### Mechanical Adaptors

#### Adaptor flange of aluminium for face mount flange, spigot 36 mm

Type	Part no.	Adaption
BEF-FA-036-050	2 029 160	to 50 mm servo flange

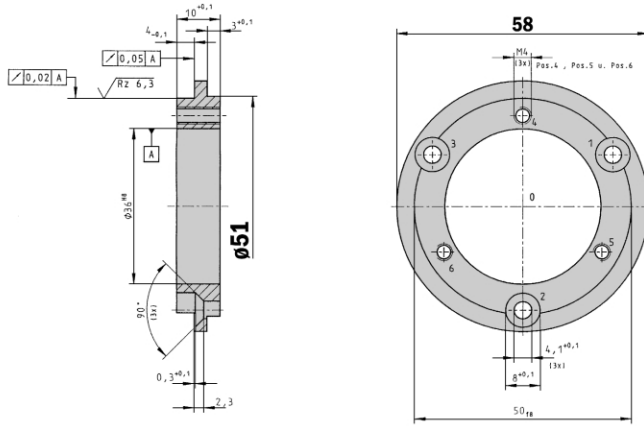

General tolerances according to DIN ISO 2768-mk

#### Adaptor flange of aluminium for face mount flange, spigot 36 mm

Type	Part no.	Adaption
BEF-FA-036-060REC	2 029 162	to 60 mm square mounting plate

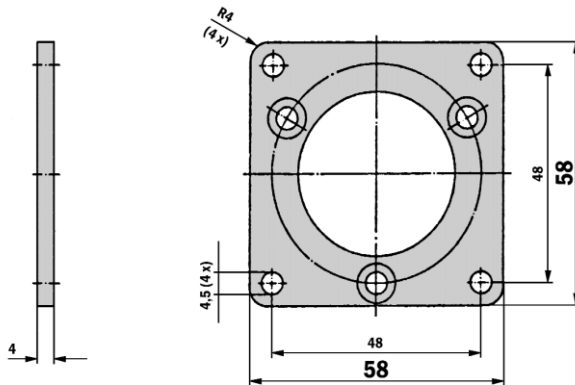

General tolerances according to DIN ISO 2768-mk

#### Adaptor flange of aluminium for face mount flange, spigot 36 mm

Type	Part no.	Adaption
BEF-FA-036-060RSA	2 029 163	to 60 mm square mounting plate with shock absorbers

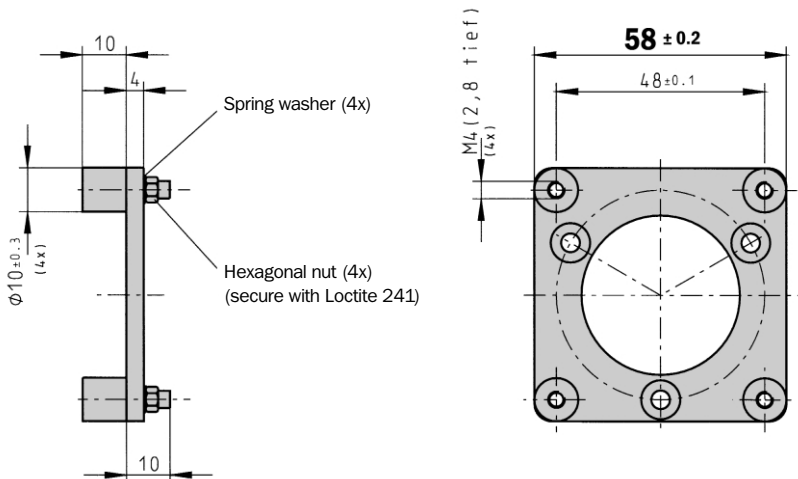

General tolerances according to DIN ISO 2768-mk

**Dimensional drawings and order information**

**Mechanical Adaptors**

**Mounting bell incl. fixing set for encoder with servo flange**

Type	Part no.	Flange spigot
BEF-MG-50	5 312 987	Diameter 50 mm

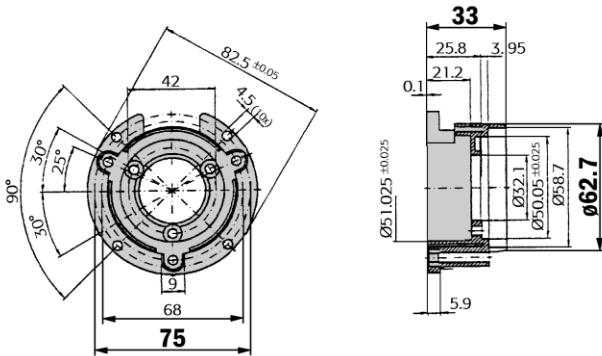

**Mounting angle incl. fixing set for encoder with face mount flange**

Type	Part no.	Flange spigot
BEF-WF-36	2 029 164	Diameter 36 mm

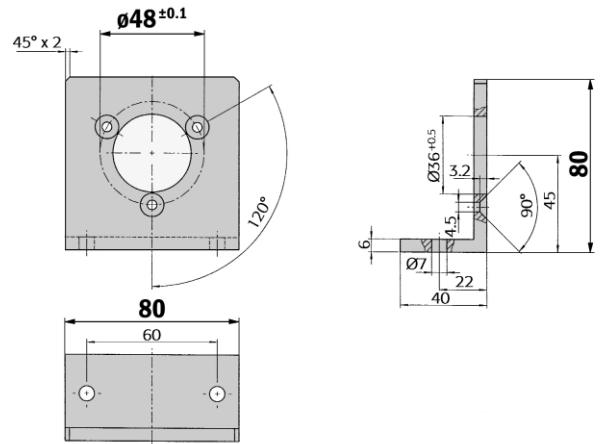

General tolerances according to DIN ISO 2768-mk

General tolerances according to DIN ISO 2768-mk

**Servo clamps half ring, Set (comprises 2 pieces) for servo flanges with spigot diameter 50 mm**

Type	Part no.
BEF-WG-SF050	2 029 165

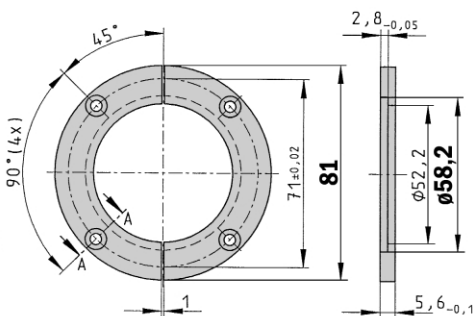

General tolerances according to DIN ISO 2768-mk

**Servo clamps small, Set (comprises 3 pieces) for servo flanges**

Type	Part no.
BEF-WK-SF	2 029 166

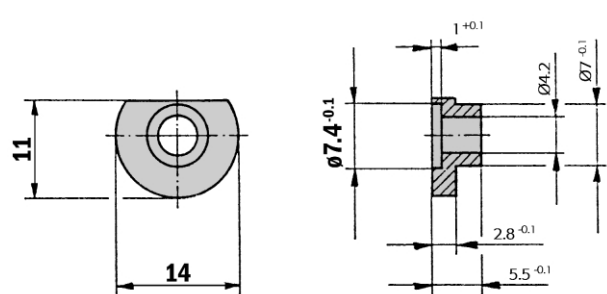

General tolerances according to DIN ISO 2768-mk

Dimensional drawings and order information

Mechanical Adaptors

Measuring wheel for encoder shafts with diameter 10 mm, type material plastic (Hytrel), wheel material plastic with aluminium hub.

Type	Part no.	Circumference
BEF-MR-010020	5 312 988	0.2 m

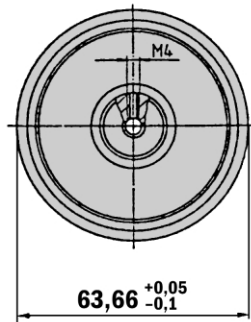

General tolerances according to DIN ISO 2768-mk

Measuring wheel for encoder shafts with diameter 10 mm, type material plastic (Hytrel), wheel material plastic with aluminium hub.

Type	Part no.	Circumference
BEF-MR-010050	5 312 989	0.5 m

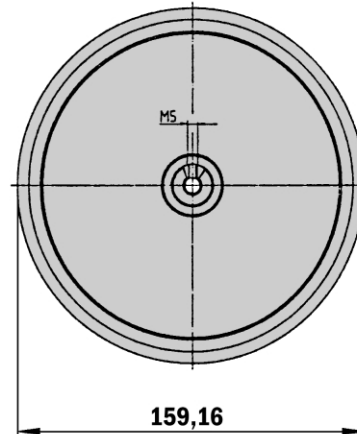

General tolerances according to DIN ISO 2768-mk

Collets

Collets for blind hollow shaft encoder

Type	Part no.	Shaft diameter
SPZ-006-AD-A	2 029 174	6 mm
SPZ-1E4-AD-A	2 029 175	1/4"
SPZ-008-AD-A	2 029 176	8 mm
SPZ-3E8-AD-A	2 029 177	3/8"
SPZ-010-AD-A	2 029 178	10 mm
SPZ-012-AD-A	2 029 179	12 mm
SPZ-1E2-AD-A	2 029 180	1/2"

Collets for through hollow shaft encoder

Type	Part no.	Shaft diameter
SPZ-006-AD-D	2 029 192	6 mm
SPZ-1E4-AD-D	2 029 193	1/4"
SPZ-008-AD-D	2 029 194	8 mm
SPZ-3E8-AD-D	2 029 195	3/8"
SPZ-010-AD-D	2 029 196	10 mm
SPZ-012-AD-D	2 029 197	12 mm
SPZ-1E2-AD-D	2 029 198	1/2"



**Australia**

Phone +61 3 94 97 41 00  
1800 33 48 02 – toll free  
Fax +61 3 94 97 11 87

**Austria**

Phone +43 (0)22 36 62 28 8-0  
Fax +43 (0)22 36 62 28 85

**Belgium/Luxembourg**

Phone +32 (0)24 66 55 66  
Fax +32 (0)24 63 31 04

**Brazil**

Phone +55 11 55 61 26 83  
Fax +55 11 55 35 41 53

**China**

Phone +8 52 27 63 69 66  
Fax +8 52 27 63 63 11

**Czech Republic**

Phone +420 2 57 91 18 50  
Fax +420 2 57 81 05 59

**Denmark**

Phone +45 45 82 64 00  
Fax +45 45 82 64 01

**Finland**

Phone +3 58 9-25 15 800  
Fax +3 58 9-25 15 8055

**France**

Phone +33 1 64 62 35 00  
Fax +33 1 64 62 35 77

**Germany**

Phone +49 (0)2 11 53 01-0  
Fax +49 (0)2 11 53 01-1 00

**Great Britain**

Phone +44 (0)17 27-83 11 21  
Fax +44 (0)17 27-85 67 67

**Italy**

Phone +39 02 92 14 20 62  
Fax +39 02 92 14 20 67

**Japan**

Phone +81 (0)3 33 58 13 41  
Fax +81 (0)3 33 58 90 48

**Korea**

Phone +82-2 786 63 21/4  
Fax +82-2 786 63 25

**Netherlands**

Phone +31 (0)30 229 25 44  
Fax +31 (0)30 229 39 94

**Norway**

Phone +47 67 81 50 00  
Fax +47 67 81 50 01

**Poland**

Phone +48 22 8 37 40 50  
Fax +48 22 8 37 43 88

**Singapore**

Phone +65 67 44 37 32  
Fax +65 68 41 77 47

**Spain**

Phone +34 93 4 80 31 00  
Fax +34 93 4 73 44 69

**Sweden**

Phone +46 86 80 64 50  
Fax +46 87 10 18 75

**Switzerland**

Phone +41 4 16 19 29 39  
Fax +41 4 16 19 29 21

Representatives and agencies  
in all major industrial nations.

**SICK | STEGMANN**