

Features:

- Acts as a gateway or interface between CAN buses with different baud rates and protocols (SAE J1939- SAE J1939 or SAE J1939-CANopen®)
- Fast data exchange between a CAN network (SAE J1939 or CANopen®) and a RS-485 bus (SAE J1587 or Modbus RTU)
- 2 Isolated CAN ports (CAN 2.0B)
- 1 Isolated RS-485 serial port
- Operational from 9 to 36 Vdc (12 Vdc, 24 Vdc nominal)
- Integrated Deutsch IPD 12-pin connector
- Fully sealed enclosure with a rugged IP67 protection rating
- Compact size
- CE mark, BV and DNV-GL type approvals
- User configurable using Axiomatic Electronic Assistant



Applications:

- Mobile (Off-Highway) Equipment
- Transport Vehicles
- Power Genset Control Systems – Control Panels for Power Generation, Marine and Oil & Gas Applications

Ordering Part Numbers:

Protocol Converter, 2 SAE J1939, Modbus RTU - P/N: **AX140100**

Protocol Converter, 2 SAE J1939, Modbus RTU, Extended Inputs - P/N: **AX140100-100**

Protocol Converter, SAE J1939, CANopen®, Modbus RTU - P/N: **AX140200**
with EDS File

Protocol Converter, SAE J1939, SAE J1939, J1587 - P/N: **AX140400**

Configuration Tool: Electronic Assistant P/N: **AX070502**

Accessories:

Mating Plug KIT (DT06-12SA, W12S, 12 0462-201-16141 contacts, 3 sealing plugs) P/N: **AX070105**

Technical Specifications:

Typical at nominal input voltage and 25 degrees C unless otherwise specified

Power

Power Supply Input - Nominal	12 V or 24 Vdc nominal; 9...36 Vdc The minimum allowable supply voltage for the power pin is 8 Vdc.
Surge Protection	95 Vdc
Reverse Polarity Protection	Provided

Control Software

Software Platform	<p>The Protocol Converter comes pre-programmed with standard protocol conversion logic for data exchange between 2 CAN networks and RS-485. The following protocols are available in the standard control logic of model AX140100.</p> <ul style="list-style-type: none"> • SAE J1939 (CAN 1 port) • SAE J1939 (CAN 2 port) • Modbus RTU (RS_485 port) <p>The AX140100-100 allows for +100 input messages.</p> <p>The following protocols are available in the standard control logic of model AX140200.</p> <ul style="list-style-type: none"> • CANopen® (CAN 2 port) • SAE J1939 (CAN 1 port) • Modbus RTU (RS_485 port) <p>The following protocols are available in the standard control logic of model AX140400.</p> <ul style="list-style-type: none"> • SAE J1939 (CAN 1 port) • SAE J1939 (CAN 2 port) • SAE J1587 (RS_485 port) <p>Custom programming for other applications is available on request.</p>
-------------------	--

General Specifications

Memory	STM32F205 32-bit, 512 Kbytes Flash Program Memory
RS-485 Port	1 Isolated RS-485
CAN Ports	2 Isolated CAN 2.0B
Isolation	300 Vrms
Quiescent Current Draw	36 mA @12 V; 19 mA @24 V
Operating Conditions	-40 to 75°C (-40 to 167°F)
Storage Temperature	-55 to 85°C (-67 to 185°F)
Enclosure and Dimensions	Aluminum enclosure, Integral TE Deutsch connector, Encapsulation Refer to dimensional drawing.

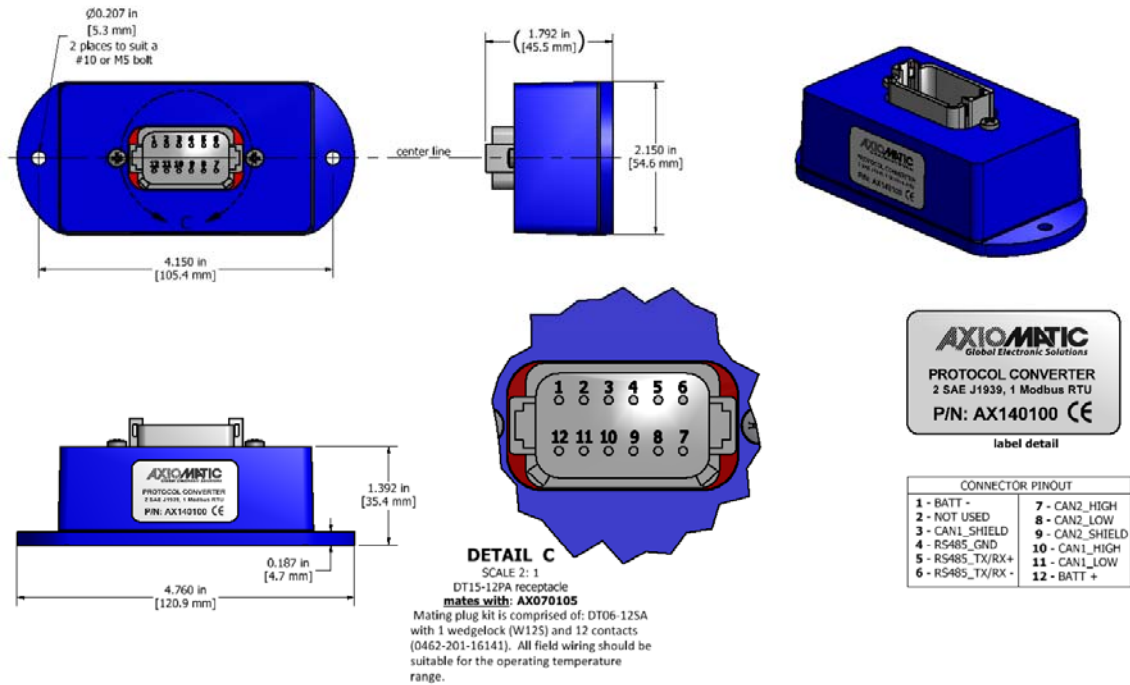

Figure 1.0 – Dimensional Drawing for AX140100, AX140200, AX140400

Electrical Connections	12 pin Deutsch IPD connector P/N: DT15-12PA A mating plug kit is available as Axiomatic P/N: AX070105 .																											
	<table border="1"> <thead> <tr> <th colspan="2">CAN and I/O Connector</th> </tr> <tr> <th>Pin #</th> <th>Description</th> </tr> </thead> <tbody> <tr> <td>1</td> <td>BATT-</td> </tr> <tr> <td>2</td> <td>NOT USED</td> </tr> <tr> <td>3</td> <td>CAN1_SH</td> </tr> <tr> <td>4</td> <td>RS485_GND (J1587 GND)</td> </tr> <tr> <td>5</td> <td>RS485_TX/RX+ (J1587 +)</td> </tr> <tr> <td>6</td> <td>RS485_TX/RX- (J1587 -)</td> </tr> <tr> <td>7</td> <td>CAN2_H</td> </tr> <tr> <td>8</td> <td>CAN2_L</td> </tr> <tr> <td>9</td> <td>CAN2_SH</td> </tr> <tr> <td>10</td> <td>CAN1_H</td> </tr> <tr> <td>11</td> <td>CAN1_L</td> </tr> <tr> <td>12</td> <td>BATT+</td> </tr> </tbody> </table>	CAN and I/O Connector		Pin #	Description	1	BATT-	2	NOT USED	3	CAN1_SH	4	RS485_GND (J1587 GND)	5	RS485_TX/RX+ (J1587 +)	6	RS485_TX/RX- (J1587 -)	7	CAN2_H	8	CAN2_L	9	CAN2_SH	10	CAN1_H	11	CAN1_L	12
CAN and I/O Connector																												
Pin #	Description																											
1	BATT-																											
2	NOT USED																											
3	CAN1_SH																											
4	RS485_GND (J1587 GND)																											
5	RS485_TX/RX+ (J1587 +)																											
6	RS485_TX/RX- (J1587 -)																											
7	CAN2_H																											
8	CAN2_L																											
9	CAN2_SH																											
10	CAN1_H																											
11	CAN1_L																											
12	BATT+																											
Weight	0.70 lbs. (0.32 kg)																											
Protection Rating	IP67; Unit is encapsulated within the housing.																											
CE marking	Compliant to the EMC Directive Compliant to the RoHS Directive																											
Vibration	4 g IEC publication 60068-2-6, Test Fc																											
Marine Type Approvals	DNG-GL and Bureau Veritas (BV)																											

Installation	<p>Mounting holes sized for #10 or M4.5 bolts. The bolt length will be determined by the end-user's mounting plate thickness. The mounting flange of the controller is 0.19 inches (4.75 mm) thick.</p> <p>If the module is mounted without an enclosure, it should be mounted to reduce the likelihood of moisture entry. Install the unit with appropriate space available for servicing and for adequate wire harness access (6 inches or 15 cm) and strain relief (12 inches or 30 cm).</p> <p>The CAN wiring is considered intrinsically safe. The power wires are not considered intrinsically safe and so in hazardous locations, they need to be located in conduit or conduit trays at all times. The module must be mounted in an enclosure in hazardous locations for this purpose.</p> <p>All field wiring should be suitable for the operating temperature range of the module.</p> <p>All chassis grounding should go to a single ground point designated for the machine and all related equipment.</p>
User Interface – SAE J1939 models	<p>For SAE J1939 models, parameters are configurable using the Electronic Assistant®.</p> <p>Axiomatic Electronic Assistant P/N: AX070502</p> <p>The Electronic Assistant for <i>Windows</i> operating systems comes with a royalty-free license for use on multiple computers. It requires an Axiomatic USB-CAN converter to link the device's CAN port to a <i>Windows</i>-based PC.</p> <p>The functionality of the Electronic Assistant includes but is not limited to the following.</p> <ul style="list-style-type: none"> • Specify CAN message filters • Allow J1939 PGN's to be transmitted over CANopen • Link J1587 bus to J1939 • Link Modbus to CAN bus • Link CANopen to J1939 • Define CANnode ID, and baud rate • Facilitate dynamic decoupling of 2 CAN networks • Monitor CAN data
User Interface – CANopen® models	.EDS provided to interface to standard CANopen ® tools

Notes:

CANopen® is a registered community trademark of CAN in Automation e.V.

Specifications are indicative and subject to change. Actual performance will vary depending on the application and operating conditions. Users should satisfy themselves that the product is suitable for use in the intended application. All our products carry a limited warranty against defects in material and workmanship. Please refer to our Warranty, Application Approvals/Limitations and Return Materials Process as described on www.axiomatic.com/service.html.

Form: TDAX140X00-08/27/21