

Gate Valve

AKG-A/AKGS-A

Type Series Booklet



Legal information/Copyright

Type Series Booklet AKG-A/AKGS-A

All rights reserved. The contents provided herein must neither be distributed, copied, reproduced, edited or processed for any other purpose, nor otherwise transmitted, published or made available to a third party without the manufacturer's express written consent.

Subject to technical modification without prior notice.

© KSB SE & Co. KGaA, Frankenthal 2022-12-07

Contents

Gate Valves.....	4
Gate valves to DIN/EN in pressure seal design.....	4
AKG-A/AKGS-A.....	4
Main applications.....	4
Fluids handled.....	4
Operating data.....	4
Valve body materials.....	4
Design details.....	4
Product benefits.....	5
Product information.....	5
Related documents.....	5
Purchase order specifications.....	5
Pressure/temperature ratings.....	6
Materials.....	7
Variants.....	8
Dimensions and weights.....	10
Installation instructions.....	13

Gate Valves

Gate valves to DIN/EN in pressure seal design

AKG-A/AKGS-A



Main applications

- Fossil-fuelled power stations
- Process engineering
- Boiler feed applications
- Boiler recirculation
- Chemical industry
- Petrochemical industry
- Sugar industry
- Mining
- Descaling units
- Paper industry / pulp industry
- Shipbuilding
- Snow-making systems
- Nuclear power stations

Fluids handled

- Water
- Steam
- Other non-aggressive fluids such as gas or oil on request.

Operating data

Table 1: Operating properties

Characteristic	Value
Nominal pressure	PN 63 - 160
Nominal size	DN 65 - 300
Max. permissible pressure [bar]	160
Min. permissible temperature [°C]	≥ -10
Max. permissible temperature [°C]	≤ +550

Selection as per pressure/temperature ratings (⇒ Page 6)

Valve body materials

Table 2: Overview of available materials

Material	Material number	Temperature limit
P 250 GH	1.0460	≤ 450 °C
13 CrMo 4-5	1.7335	≤ 550 °C

Design details

Design

- Pressure seal design
- Non-rotating stem
- Split wedge
- Yoke head suitable for mounting electric and pneumatic actuators (DIN ISO 5210)

Variants

- Body made of forged steel
- Position indicator
- Limit switch(es)
- Drain branch
- Hard-faced back seat
- Disc spring supported yoke head
- Parallel discs
- Bypass
- Spur gear
- Bevel gear
- Electric actuators
- Pneumatic actuators
- Actuating bush for remote actuation
- Other flange designs
- Other butt weld end versions
- Inspections to technical codes such as TRD/TRB/AD2000 – German Steam Boiler / Pressure Vessel Regulations – or to customer specification

Product benefits

- Additional features ensure safe sealing to atmosphere:
 - Pressure seal bonnet. Low risk of leakage, particularly at high pressures and temperatures.
 - Graphite gland packing with packing end rings.
- Reliable, tight shut-off and service-friendly design
 - Wedge holder with flexibly mounted split wedge. Precise alignment of wedge discs with body; wedge discs are easy to replace.
 - Actuating moments are absorbed by the wedge holder guided in the body. No additional loads on the wedge discs and the seat/disc interface.
 - Standard DIN/ISO top flange at the yoke head simplifies actuator mounting.
- Additional safety and blow-out protection by standard back seat.
- Long service life and high functional reliability
 - Stop nut as standard. Limited wedge action prevents jamming in closed position and ensures reliable opening of the gate valve even in the event of temperature transients.
 - Of the gland packing due to non-rotating stem with burnished shank.
 - Threaded bush runs in ball bearings for smooth actuation.
 - Hard-faced seat/disc interface made of wear-resistant and corrosion-proof 17 % chrome steel or Stellite.

Product information

Product information as per Regulation No. 1907/2006 (REACH)

For information as per European chemicals regulation (EC) No. 1907/2006 (REACH) see <https://www.ksb.com/en-global/company/corporate-responsibility/reach>.

Product information as per Directive 2014/34/EU (ATEX)

The valves do not have a potential internal source of ignition and can be used in potentially explosive atmospheres, Group II, category 2 (zones 1+21) and category 3 (zone 2+22) to ATEX 2014/34/EU.

Product information as per Pressure Equipment Directive 2014/68/EU (PED)

The valves satisfy the safety requirements of Annex I of the European Pressure Equipment Directive 2014/68/EU (PED) for fluids in Groups 1 and 2.

Product information as per UK Equipment and Protective Systems Intended for Use in Potentially Explosive Atmospheres Regulations 2016

The valves do not have a potential internal source of ignition and can be used in accordance with the UK's Equipment and Protective Systems Intended for Use in Potentially Explosive Atmospheres Regulations 2016 in potentially explosive atmospheres, Group II, category 2 (zones 1+21) and category 3 (zone 2+22).

Product information as per UK Pressure Equipment (Safety) Regulations 2016

The valves satisfy the safety requirements of the UK Pressure Equipment (Safety) Regulations 2016 (PER) for fluids in Groups 1 and 2.

Related documents

Table 3: Information/documents

Document	Reference number
AKR/AKRS type series booklet (swing check valves with pressure seal cover)	7373.1
UGS/UGSV/UGSVA type series booklet (body pressure relief valve)	7300.1
Operating manual	0570.81

Purchase order specifications

Please specify the following information in all enquiries or purchase orders:

1. Type
2. Nominal pressure
3. Nominal size
4. Operating pressure
5. Differential pressure
6. Operating temperature
7. Material
8. Fluid handled
9. Flow rate
10. Pipe connection
11. Variants
12. Reference number

Always indicate the original serial number and the year of construction when ordering spare parts.

Pressure/temperature ratings

Flanged (AKG-A) or machined butt weld ends (AKGS-A)

**Table 4: Permissible operating pressures [bar]¹⁾
(to EN 1092-1)²⁾**

PN	Material		[°C]																			
	Designation	Number	RT ³⁾	100	150	200	250	300	350	400	450	460	470	480	490	500	510	520	530	540	550	
63	P 250 GH	1.0460	63,0	58,5	55,5	52,5	48,0	43,5	40,5	37,5	20,7	-	-	-	-	-	-	-	-	-	-	-
	13 CrMo 4-5	1.7335	63,0	63,0	63,0	63,0	63,0	63,0	60,0	56,7	53,1	50,5	47,9	45,4	42,8	41,1	34,8	28,2	23,4	18,3	14,7	
100	P 250 GH	1.0460	100,0	92,8	88,0	83,3	76,1	69,0	64,2	59,5	32,8	-	-	-	-	-	-	-	-	-	-	-
	13 CrMo 4-5	1.7335	100,0	100,0	100,0	100,0	100,0	100,0	95,2	90,0	84,2	80,2	76,1	72,0	68,0	65,2	55,2	44,7	37,1	29,0	23,3	
160	P 250 GH	1.0460	160,0	148,5	140,9	133,3	121,9	110,4	102,8	95,2	52,5	-	-	-	-	-	-	-	-	-	-	-
	13 CrMo 4-5	1.7335	160,0	160,0	160,0	160,0	160,0	160,0	152,3	144,0	134,8	128,3	121,8	115,3	108,8	104,3	88,3	71,6	59,4	46,4	37,3	

Table 5: Unmachined butt weld ends, type AKGS-A
Permissible operating pressures [bar]¹⁾

PN	Material		[°C]																
	Designation	Number	RT ³⁾	100	200	250	300	350	400	425	450	475	500	510	520	530	540	550	
160	P 250 GH	1.0460	160	160	160	140	120	100	80	72	60	-	-	-	-	-	-	-	
	13 CrMo 4-5	1.7335	160	160	160	160	160	160	150	147	145	140	118	100	80	67	52	42	

1 The valves are suitable for temperatures down to -10 °C.
 2 Operating pressures to DIN 2401 are also permissible.
 3 RT: room temperature (-10 °C to +50 °C)

Materials

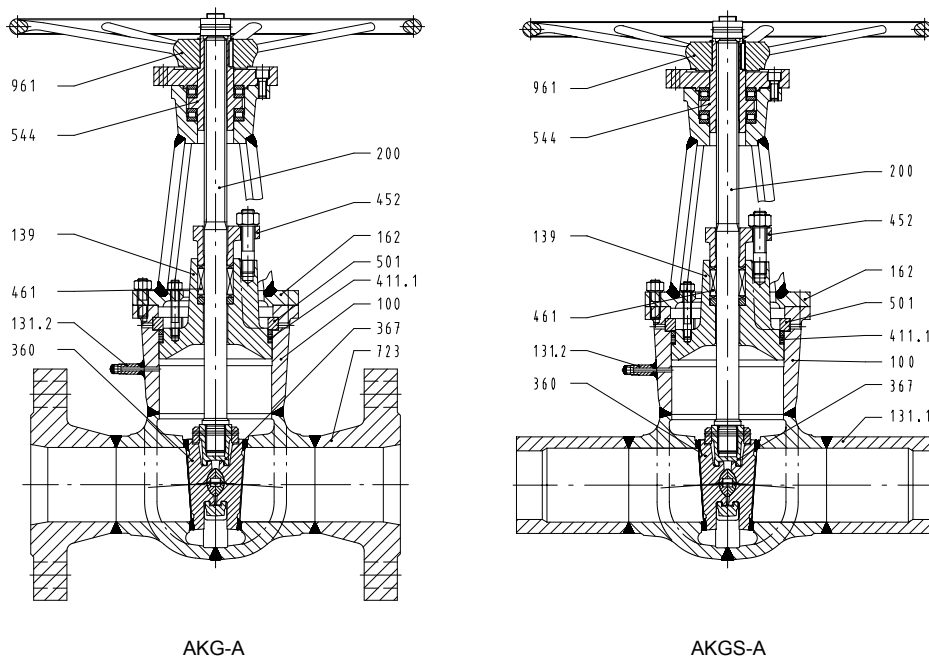

Fig. 1: Sectional drawings of AKG-A/AKGS-A

Table 6: Parts list DN 65/80 - 300/250

Part No.	Description	Temperature [°C]	Material	Material number	Note
100	Body	≤ 450	P 250 GH	1.0460	Body die-forged and welded
		≤ 550	13 CrMo 4-5	1.7335	
723	Flange	≤ 450	P 250 GH	1.0460	-
		≤ 550	13 CrMo 4-5	1.7335	-
131.1	Connection branch	≤ 450	P 250 GH	1.0460	Material can be matched to piping material
		≤ 550	13 CrMo 4-5	1.7335	
139	Bonnet	≤ 450	P 250 GH	1.0460	-
		≤ 550	13 CrMo 4-5	1.7335	
360 ⁴⁾	Wedge discs	≤ 450	P 250 GH	1.0460	-
		≤ 550	13 CrMo 4-5	1.7335	
367 ⁴⁾	Disc/wedge holder	≤ 450	P 250 GH	1.0460	-
		≤ 550	13 CrMo 4-5	1.7335	
162	Yoke bonnet	≤ 550	C 22 N	1.0402	Welded design
131.2	Connection branch	≤ 450	P 250 GH	1.0460	-
		≤ 550	13 CrMo 4-5	1.7335	
Seat/disc interface	Body	≤ 450	Hard-faced	1.4115	Hard-faced
	Wedge discs	≤ 550	Stellite hard-faced	-	
200 ⁴⁾	Stem	≤ 550	X 39 CrMo 17-1	1.4122	-
411.1 ⁴⁾	Joint ring		Pure graphite	-	-
452	Gland follower		13 CrMo 4-5	1.7335	-
461 ⁴⁾	Gland packing		Pure graphite	-	With packing end rings
501	Segmental ring		13 CrMo 4-5	1.7335	-
544 ⁴⁾	Threaded bush		Cu Zn 35 Ni 2	2.0540	On cylindrical roller bearings
961 ⁴⁾	Handwheel		EN-GJL-250	5.1301	≥ DN 150 made of steel (welded)

7338.1/23-EN

⁴ Recommended spare parts

Variants

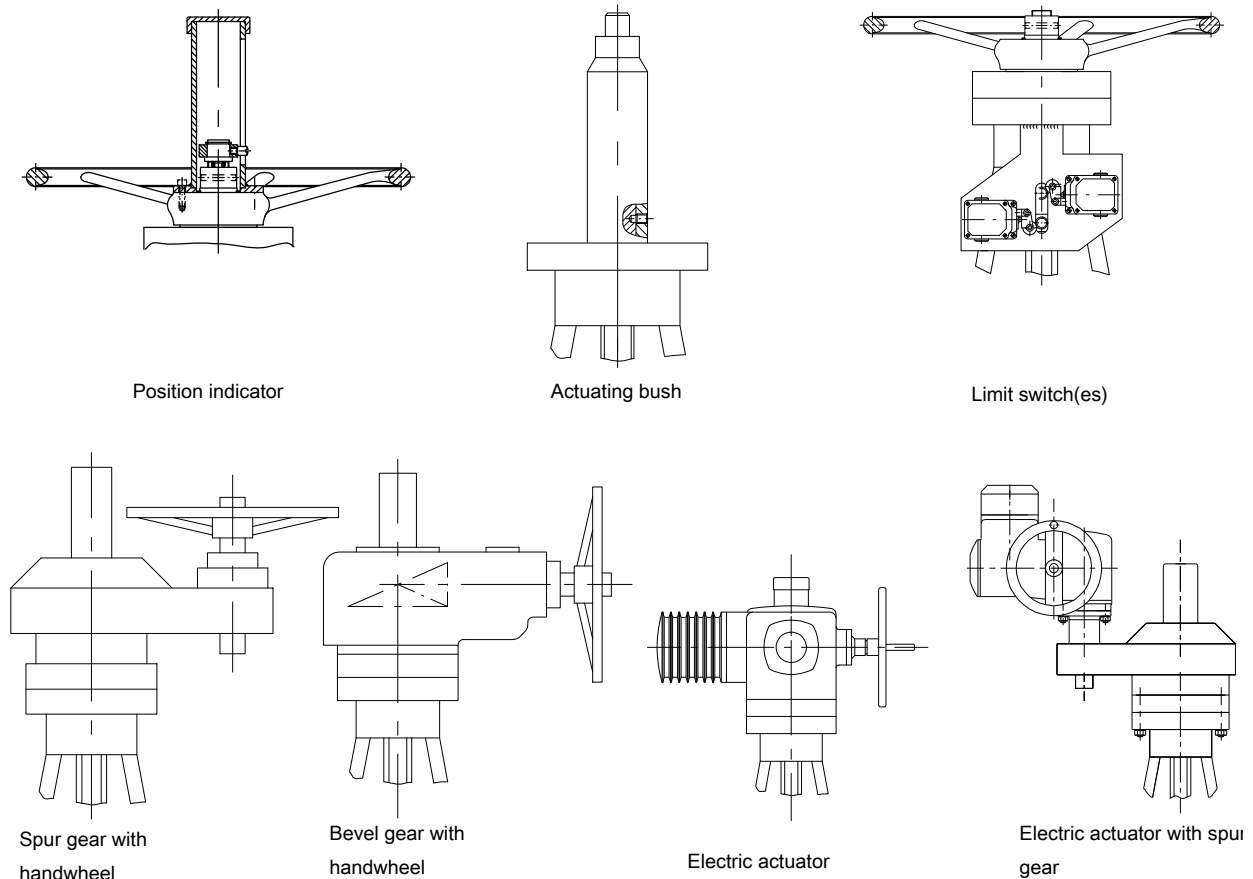

Fig. 2: Variants

Body pressure relief valve

Also refer to type series booklet 7300.1.

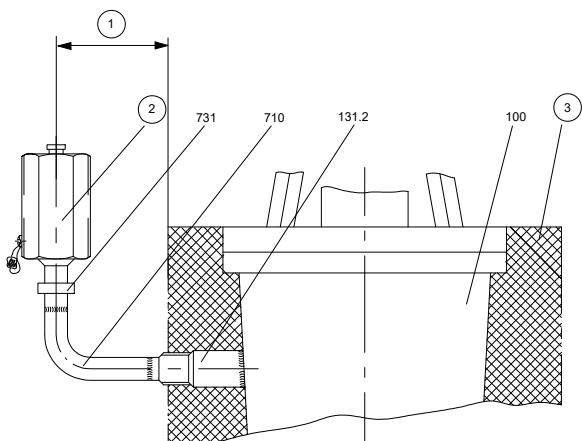

Fig. 3: UGS/UGSV body pressure relief valve on gate valve in pressure seal design

①	200 mm minimum distance	②	Body pressure relief valve for both flow directions
③	Insulation	100	Body
131.2	Connection branch	710	Pipe, not included in KSB's scope of supply
731	Pipe union		

A body pressure relief valve is necessary if, with the gate valve closed, there is a danger of the liquid trapped inside the valve body heating up and causing an unacceptable pressure increase inside the valve. A warning sign is affixed to the yoke arm near the name plate.

All gate valves with pressure seal bonnet are factory-supplied with a closed connection branch 131.2 with connection dimensions $\varnothing 22 \text{ mm} / \varnothing 14.1 \text{ mm}$ suitable for pipe $\varnothing 21.3 \text{ mm} \times 3.6 \text{ mm}$.

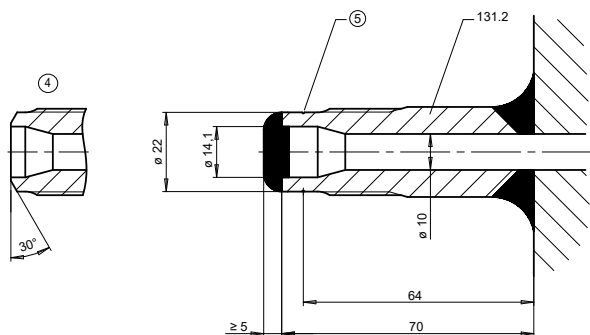

Fig. 4: Closed connection branch for body pressure relief valve

④	Welding groove	⑤	When connecting to pipe 710, cut here and bevel the face to obtain a welding groove.
131.2	Connection branch		

When ordering please state whether a pressure relief valve is to be provided, or whether excess pressure is to be released via a bypass and/or a relief hole in the inlet-side seat ring 515. In those cases, the gate valves can be used for one flow direction only.

i The pressure relief valve must not be welded directly to connection branch 131.2 but must be connected to it via an intermediate pipe 710 in a vertical, upright position outside the insulating material. The minimum distance to the insulation is 200 mm.

Dimensions and weights

Dimensions and weights of AKG-A

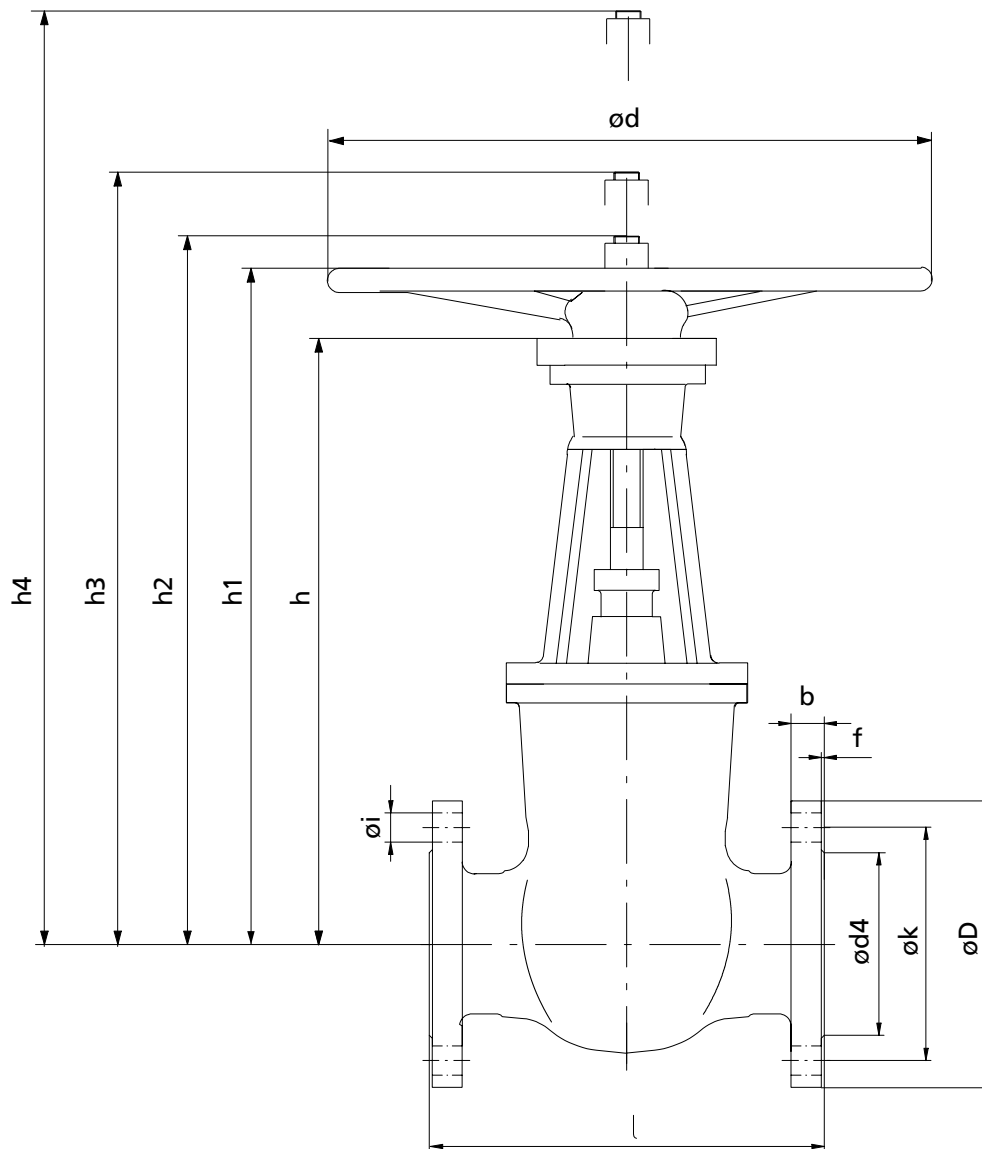

Fig. 5: AKG-A

Table 7: Dimensions and weights

PN	DN/S ⁵⁾⁶⁾	l	ø D	ø k	No. of bolt holes z	Bolt hole ø i	ø d ₄ × f	b	h	h ₁	h ₂	h ₃ ⁷⁾	h ₄ ⁸⁾	Travel	ø d	[kg]
63	80/80	310	215	170	8	22	138 × 3	28	455	520	530	610	800	80	400	65
	100/100	350	250	200	8	26	162 × 3	30	515	585	605	705	900	100	400	95
	125/125	400	295	240	8	30	188 × 3	34	570	640	650	775	1050	125	500	140
	150/150	450	345	280	8	33	218 × 3	36	680	765	775	925	1250	150	640	155
	200/200	550	415	345	12	36	285 × 3	42	840	930	945	1135	1550	190	800	280
	250/250	650	470	400	12	36	345 × 3	46	1065	1110	1110	1350	1950	240	800	660
100	80/80	310	230	180	8	26	138 × 3	32	455	520	530	560	800	80	400	70

5 Nominal size / seat diameter
6 Model with reduced bore on request
7 Open
8 Vertical clearance for removal

PN	DN/S ⁵⁾⁶⁾	l	ø D	ø k	No. of bolt holes z	Bolt hole ø i	ø d ₄ × f	b	h	h ₁	h ₂	h ₃ ⁷⁾	h ₄ ⁸⁾	Travel	ø d	[kg]
		[mm]	[mm]	[mm]		[mm]	[mm]	[mm]	[mm]	[mm]	[mm]	[mm]	[mm]	[mm]	[mm]	[mm]
100	100/100	350	265	210	8	30	162 × 3	36	515	585	605	705	900	100	400	100
	125/125	400	315	250	8	33	188 × 3	40	570	640	650	775	1050	125	500	150
	150/150	450	355	290	12	33	218 × 3	44	680	765	775	925	1250	150	640	210
	200/200	550	430	360	12	36	285 × 3	52	840	930	945	1135	1550	190	800	320
	250/250	700 ⁹⁾	505	430	12	39	345 × 3	60	1065	1110	1110	1350	1950	240	800	720
160	80/80	390	230	180	8	26	138 × 3	36	455	520	530	560	800	80	400	75
	100/100	450	265	210	8	30	162 × 3	40	515	585	605	705	900	100	400	105
	125/125	525	315	250	8	33	188 × 3	44	570	640	650	775	1050	125	500	160
	150/150	600	355	290	12	33	218 × 3	50	680	765	775	925	1250	150	640	220
	200/200	750	430	360	12	36	285 × 3	60	840	930	945	1135	1550	190	800	380
250/250	900	515	430	12	42	345 × 3	68	1065	1110	1110	1350	1950	240	800	740	

Mating dimensions as per standard

Face-to-face lengths: PN 63 and PN 100 to EN 558-1/26
PN 160, see table

Flanges: Mating dimensions to EN 1092-1

Flange facing: Type B

Other flange designs

- For example, undrilled with groove (type D) or recess (type F) to EN 1092-1 at both ends
- Flanges to DIN
- Other flange designs on request

⁹ Contrary to EN 558-1/26

Dimensions and weights of AKGS-A

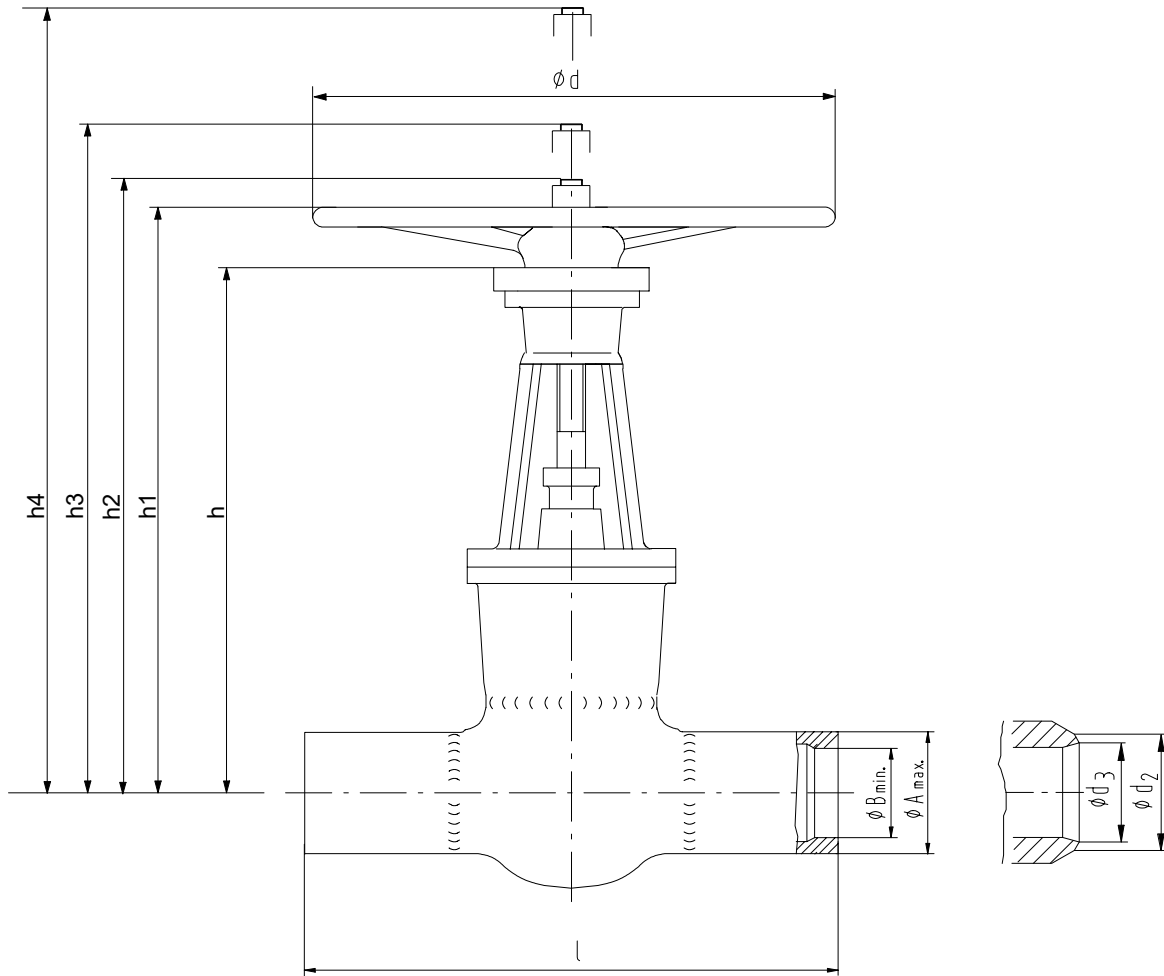

Fig. 6: AKGS-A

Table 8: Dimensions and weights

PN	DN/ S ^(10/11)	I	Butt weld ends, unmachined			Butt weld ends, machined									h	h ₁	h ₂	h ₃ ⁽¹²⁾	h ₄ ⁽¹³⁾	Travel	ø d	[kg]
			ø A _{max.}	ø B _{min.}	PN 63			PN 100			PN 160											
					ø d ₂	ø d ₃	Pipe dimensions	ø d ₂	ø d ₃	Pipe dimensions	ø d ₂	ø d ₃	Pipe dimensions									
			[mm]	[mm]	[mm]	[mm]	[mm]	[mm]	[mm]	[mm]	[mm]	[mm]	[mm]	[mm]								
63/160	65/80	390	95	50	76,1	69,0	76,1 × 3,6	77,0	68,0	76,1 × 4,0	77,0	64,5	76,1 × 5,6	455	520	530	610	800	80	400	60	
	80/80	390	95	65	90,0	81,0	88,9 × 4,0	90,0	80,0	88,9 × 4,5	90,0	76,0	88,9 × 6,3	455	520	530	610	800	80	400	60	
	100/80	450	120	89	115,0	104,0	114,3 × 5,0	115,0	103,0	114,3 × 5,6	115,5	98,0	114,3 × 8,0	455	520	530	610	800	80	400	65	
	100/100	450	120	92	115,0	104,0	114,3 × 5,0	115,0	103,0	114,3 × 5,6	115,5	98,0	114,3 × 8,0	515	585	605	705	900	100	400	85	
	125/100	525	145	105	141,0	130,0	139,7 × 5,0	141,5	127,0	139,7 × 6,3	141,0	120,0	139,7 × 10,0	515	585	605	705	900	100	400	100	
	125/125	525	145	98	141,0	130,0	139,7 × 5,0	141,5	127,0	139,7 × 6,3	141,0	120,0	139,7 × 10,0	570	640	650	775	1050	125	500	125	
	150/125	600	175	138	170,0	156,5	168,3 × 5,6	170,5	152,0	168,3 × 8,0	170,5	143,0	168,3 × 12,5	570	640	650	775	1050	125	500	130	
	150/150	600	175	138	170,0	156,5	168,3 × 5,6	170,5	152,0	168,3 × 8,0	170,5	143,0	168,3 × 12,5	680	765	775	925	1250	150	640	175	
	175/150	675	200	150	195,0	180,5	193,7 × 6,3	197,0	176,0	193,7 × 8,8	196,0	165,0	193,7 × 14,2	680	765	775	925	1250	150	640	190	
	200/150	750	225	165	222,0	204,5	219,1 × 7,1	222,0	199,0	219,1 × 10,0	222,0	187,0	219,1 × 16,0	680	765	775	925	1250	150	640	200	
	200/200	750	225	180	222,0	204,5	219,1 × 7,1	222,0	199,0	219,1 × 10,0	222,0	187,0	219,1 × 16,0	840	930	945	1135	1550	190	800	255	
	250/200	900	280	225	276,0	255,0	273,0 × 8,8	276,0	247,5	273,0 × 12,5	276,0	229,0	273,0 × 22,2	840	930	945	1135	1550	190	800	315	
	250/250	900	280	225	276,0	255,0	273,0 × 8,8	276,0	247,5	273,0 × 12,5	276,0	229,0	273,0 × 22,2	1065	1110	1110	1350	1950	240	800	630	
	300/250	1050	330	260	325,0	301,0	323,9 × 11,0	327,0	292,0	323,9 × 16,0	325,0	274,0	323,9 × 25,0	1065	1110	1110	1350	1950	240	800	680	

- 10 Nominal size / seat diameter
- 11 Model with reduced bore on request
- 12 Open
- 13 Vertical clearance for removal

Mating dimensions as per standard

Face-to-face lengths: See table
 Butt weld ends: See table
 Weld groove form: DIN EN ISO 9692-1 (1.3 + 1.5)

Different designs of butt weld ends and weld groove forms are possible, but only within the dimensions $A_{max.}$ and $B_{min.}$.
 Butt weld ends to EN 12627 are possible.

Installation instructions

The gate valves are designed for a max. differential pressure equal to the permissible operating pressure.

If a bypass is necessary or requested for other reasons, a NORI 320 ZXS globe valve as per type series booklet 7640.1 is fitted as bypass valve. The nominal size of the globe valve depends on the nominal size of the gate valve (see table).

Table 9: Nominal size of bypass valve

Gate valve seat diameter	Nominal size of bypass valve
S 80 - 150	DN 15
S 200 - 250	DN 25



KSB SE & Co. KGaA
Bahnhofplatz 1 • 91257 Pegnitz (Germany)
Tel. +49 9241 71-0
www.ksb.com