

# Data and signal protection

## ESP H Series

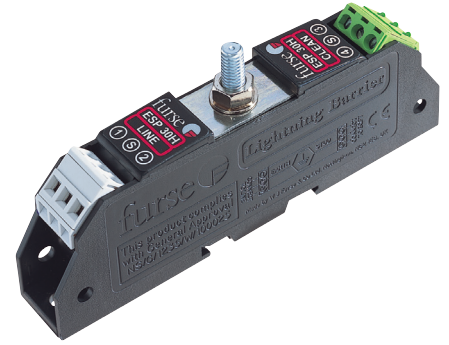

Combined Category D, C, B tested protector (to BS EN 61643) suitable for twisted pair signalling applications which require either a lower in-line resistance or an increased current than the ESP D or E Series. Also suitable for DC power applications less than 4 Amps. Available for working voltages of up to 6, 15, 30, 50 and 110 Volts. For use at boundaries up to LPZ 0 to protect against flashover (typically the service entrance location) through to LPZ 3 to protect sensitive electronic equipment.

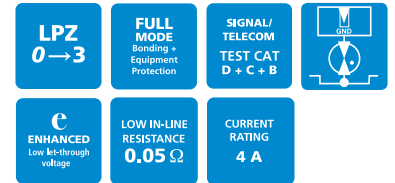

### Features & benefits

- Very low let-through voltage (enhanced protection to IEC/BS EN 62305) between all lines - Full Mode protection
- Full Mode design capable of handling partial lightning currents as well as allowing continual operation of protected equipment
- Repeated protection in lightning intense environments
- Ultra-low (< 0.05 Ω) in-line resistance allows resistance critical applications (e.g. alarm loops) to be protected
- Very high (4 A) maximum running current
- Strong, flame retardant ABS housing
- Supplied ready for flat mounting on base or side
- Built-in DIN rail foot for simple clip-on mounting to top hat DIN rails
- Colour coded terminals give a quick and easy installation check - grey for the dirty (line) end and green for clean
- Screen terminal enables easy connection of cable screen to earth
- Substantial earth stud to enable effective earthing
- Integral earth plate enables enhanced connection to earth via CME kit

### Installation

Connect in series with the data communication or signal line either near where it enters or leaves the building or close to the equipment being protected (e.g. within its control panel). Either way, it must be very close to the system's earth star point. Install protectors either within an existing cabinet/cubicle or in a separate enclosure.

### Application

Use these applications to protect resistance sensitive or higher running current systems, e.g. systems with long signal lines, or DC power applications.

### Accessories

Combined Mounting/Earthing kits:

- CME 4** Mount & earth up to 4 protectors
- CME 8** Mount & earth up to 8 protectors
- CME 16** Mount & earth up to 16 protectors
- CME 32** Mount & earth up to 32 protectors

Weatherproof enclosures:

- WBX 2/G**  
For use with up to 2 protectors
- WBX 3, WBX 3/G**  
For use with up to 3 protectors
- WBX 4, WBX 4/GS**  
For use with a CME 4 and up to 4 protectors
- WBX 8, WBX 8/GS**  
For use with a CME 8 and up to 8 protectors
- WBX 16/2/G**  
For use with one or two CME 16 and up to 32 protectors

### Install in series (in-line)

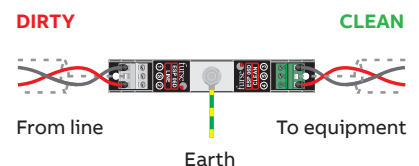

**NOTE:** For some data and signal applications with lower current, higher in-line resistance or higher bandwidth requirements, the ESP D or E Series protectors or the Slim Line ESP SL Series may be more suitable. If the protector is to be mounted directly onto a PCB, use the ESP PCB/\*\*D or ESP PCB/\*\*E protectors.

**ESP H Series - Technical specification**

Electrical specification	ESP 06H	ESP 15H	ESP 30H	ESP 50H	ESP 110H
<b>ABB order code</b>	7TCA085400R0003	7TCA085400R0009	7TCA085400R0011	7TCA085400R0012	7TCA085400R0008
Nominal voltage <sup>(1)</sup>	6 V	15 V	30 V	50 V	110 V
Maximum working voltage U <sub>c</sub> (RMS/DC) <sup>(2)</sup>	5 V / 7.79 V	11 V / 16.7 V	25 V / 36.7 V	40 V / 56.7 V	93 V / 132 V
Current rating (signal)	4 A				
In-line resistance (per line ±10%)	0.05 Ω				
Bandwidth (-3 dB 50 Ω system)	160 KHz	140 KHz	130 KHz	120 KHz	120 KHz
Transient specification	ESP 06H	ESP 15H	ESP 30H	ESP 50H	ESP 110H
<b>Let-through voltage (all conductors)<sup>(3)</sup> Up</b>					
C2 test 4 kV 1.2/50 μs, 2 kA 8/20 μs to BS EN/EN/IEC 61643-21	12.0 V	27.5 V	46.0 V	67.0 V	150 V
C1 test 1 kV, 1.2/50 μs, 0.5 kA 8/20 μs to BS EN/EN/IEC 61643-21	11.0 V	26.5 V	45.0 V	66.5 V	145 V
B2 test 4 kV 10/700 μs to BS EN/EN/IEC 61643-21	10.5 V	25.5 V	43.5 V	65.0 V	140 V
5 kV, 10/700 μs <sup>(4)</sup>	10.8 V	26.2 V	44.3 V	65.8 V	145 V
<b>Maximum surge current</b>					
D1 test 10/350 μs to BS EN/EN/IEC 61643-21:	- Per signal wire - Per pair	2.5 kA 5 kA			
8/20 μs to ITU-T K.45:2003, IEEE C62.41.2:2002:	- Per signal wire - Per pair	10 kA 20 kA			
Mechanical specification	ESP 06E	ESP 15E	ESP 30E	ESP 50E	ESP 110E
Temperature range	-40 to +80 °C				
Connection type	Screw terminal - maximum torque 0.5 Nm				
Conductor size (stranded)	2.5 mm <sup>2</sup>				
Earth connection	M6 stud - maximum torque 0.5 Nm				
Case material	FR Polymer UL-94 V-0				
Weight: - Unit	0.08 kg				
Dimensions	See diagram below				

- <sup>(1)</sup> Nominal voltage (RMS/DC or AC peak) measured at < 10 μA (ESP 15H, ESP 30H, ESP 50H, ESP 110H) and < 200 μA (ESP 06H)
- <sup>(2)</sup> Maximum working voltage (RMS/DC or AC peak) measured at < 5 mA leakage (ESP 15H, ESP 30H, ESP 50H, ESP 110H) and < 10 mA (ESP 06H)
- <sup>(3)</sup> The maximum transient voltage let-through of the protector throughout the test (±10%), line to line & line to earth, both polarities. Response time < 10 ns
- <sup>(4)</sup> Test to IEC 61000-4-5:2006, ITU-T (formerly CCITT) K.20, K.21 and K.45, Telcordia GR-1089-CORE, Issue 2:2002, ANSI TIA/EIA/IS-968-A:2002 (formerly FCC Part 68)

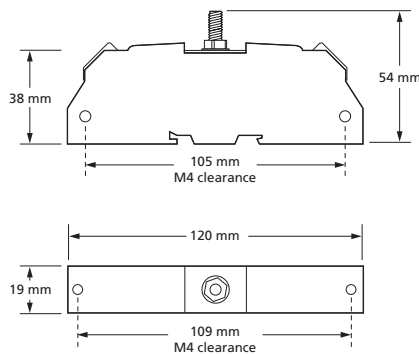

**ABB order codes**

Part	ABB order code	Part	ABB order code	Part	ABB order code
<b>CME4</b>	7TCA085400R0001	<b>CME8</b>	7TCA085400R0002	<b>CME16</b>	7TCA085410R0002
<b>CME32</b>	7TCA085410R0003	<b>WBX 2/G</b>	7TCA085410R0022	<b>WBX 3</b>	7TCA085410R0023
<b>WBX 3/G</b>	7TCA085410R0024	<b>WBX 4</b>	7TCA085410R0027	<b>WBX 4/GS</b>	7TCA085410R0028
<b>WBX 8</b>	7TCA085410R0030	<b>WBX 8/GS</b>	7TCA085410R0031	<b>WBX 16/2/G</b>	7TCA085410R0020