

DATASHEET

Magnetically coupled pump

RM 4.5 – 27/750

Motor output

5,5kW / 7,5kW / 11,0kW
2900 or 3450 rpm [2-pol.]



Magnetically coupled, centrifugal pumps, single-stage, horizontal, non self-priming, made in monobloc design.

				RM4.5 - 27/750					
Motor output	[kW]	5,5		7,5		11,0			
Rated current @ 400V 50Hz 3ph.	[A]	10,5		13,5		22,0			
Head max.	[mWS]	29		29		29			
Capacity max.	[l/min.]	800		900		900			
Density max. @ Qmax	[g/cm³]	1,0		1,25		1,8			
Length „L“	IE2	IE3	[mm]	630	700	700	735	785	785

Materials:



Technical data

Medium-temperature max.	PP PVDF Edelstahl	80 °C 95 °C 100 °C	<h3>Flow curves RM4.5 - 27/750</h3> <p>Speed: 2900 rpm @ 50Hz or 3450 rpm @ 60Hz</p> <p>Values based on water at 20 °C (68 °F) / Measured value +/- 10%</p> <p>Subject to technical alterations !</p>
System-pressure max.	PP PVDF Edelstahl	5,0 bar 6,0 bar 10,0 bar	
Viscosity	< 160 Pa s		
Electrical motor	3-ph. motors, 50 and 60Hz, IE2, IE3 or IE4 Protection IP55, Isolationclass F , Chemical resistant 2K- painting RAL5011		
Options	<i>Thermal protection, other voltages / frequencies, UL, CSA, Special paintings and colors</i>		

DATASHEET

Magnetically coupled pump

RM 4.5 – 27/750

Motor output
5,5kW / 7,5kW / 11,0kW
2900 or 3450 rpm [2-pol.]



Dimensional drawings [mm]

Motor output 5,5kW IE2

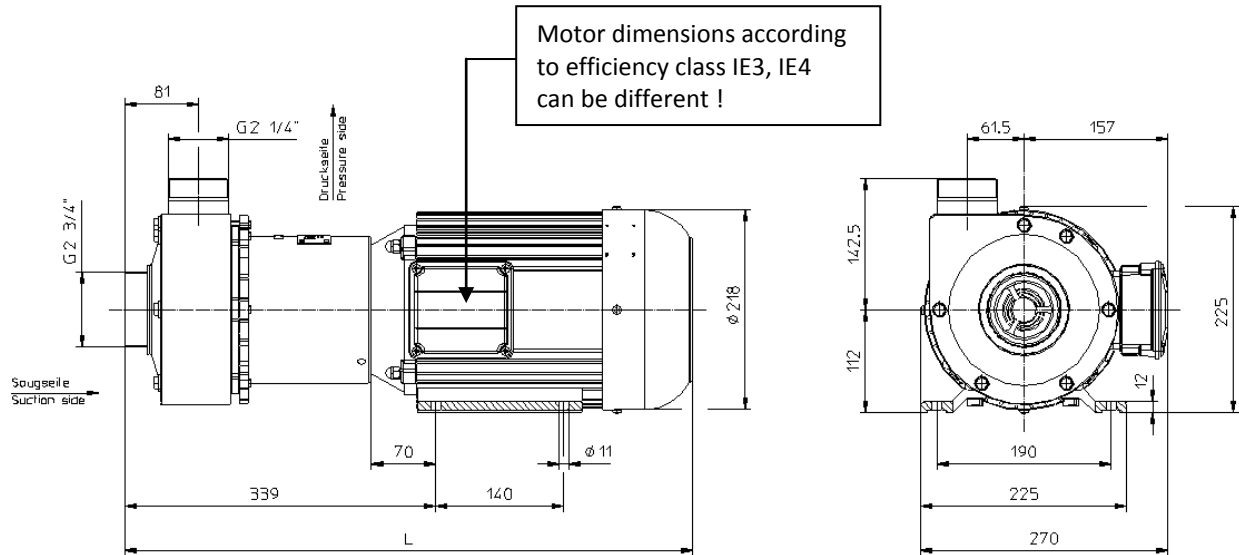

Motor output 7,5kW IE2 + IE3

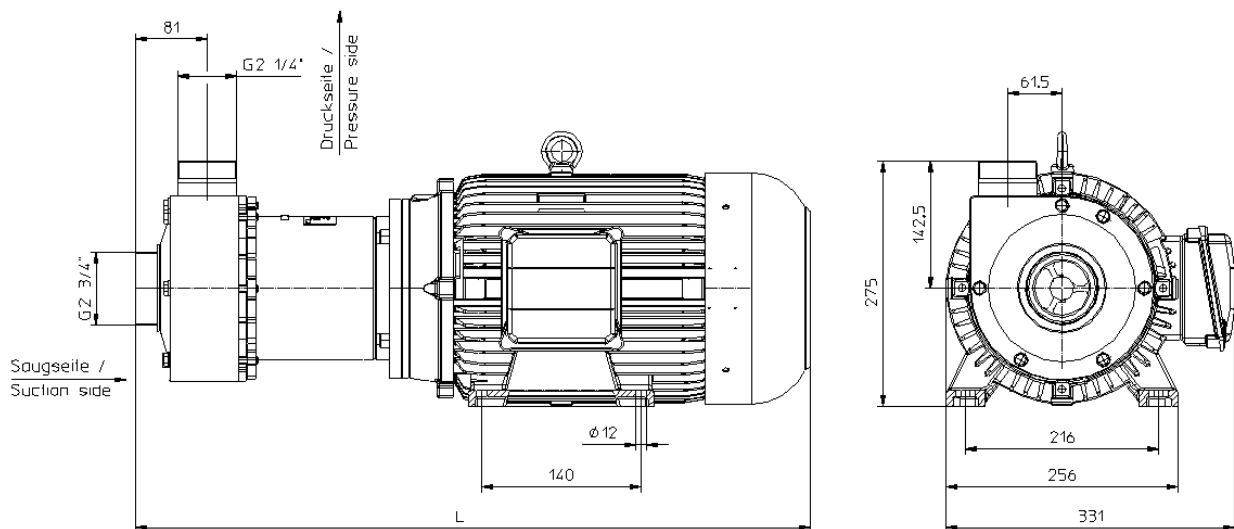

Motor dimensions can be different ! • Subject to technical alterations !

DATASHEET

Magnetically coupled pump

RM 4.5 – 27/750

Motor output
5,5kW / 7,5kW / 11,0kW
2900 or 3450 rpm [2-pol.]

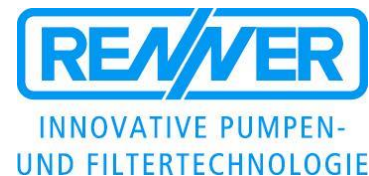

Motor output 11,0kW IE3

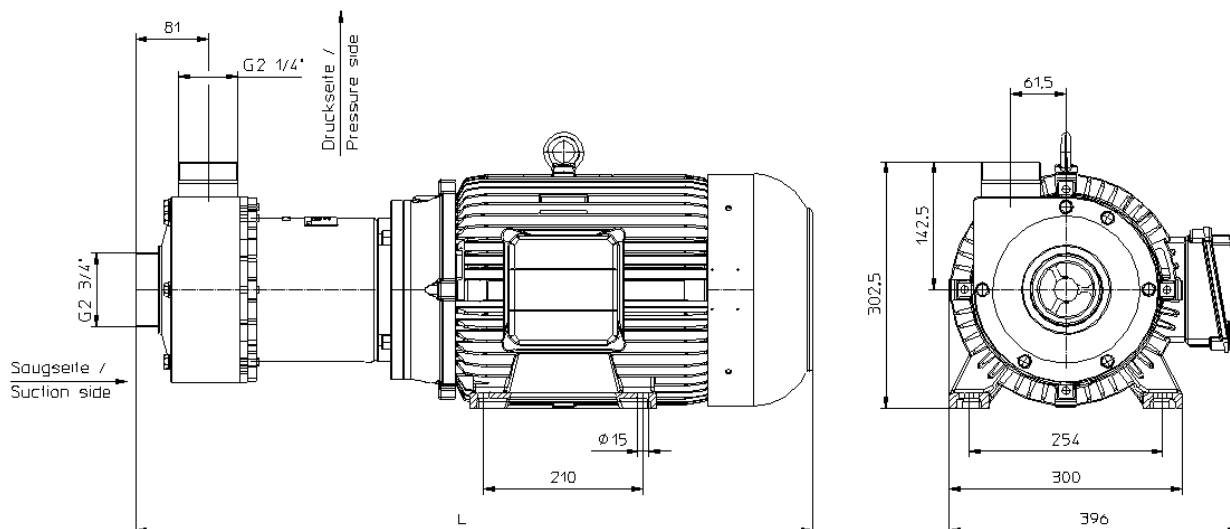

Motor dimensions can be different ! • Subject to technical alterations !

Accessories / Options

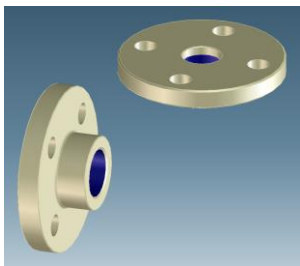
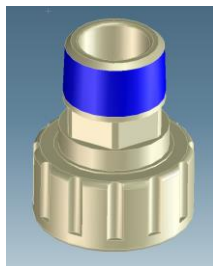
Hose connection	Flange (DIN, ANSI)	NPT - Adapter
 <p>40mm 50mm 63mm</p>	 <p>DN50 PN10 (DIN EN 1092-3) DN65 PN10 (DIN EN 1092-3) 2.5" (ANSI Class 150) 2" (ANSI Class 150)</p>	 <p>NPT (M) 2.5" NPT (M) 3"</p>

DATASHEET

Magnetically coupled pump

RM 4.5 – 27/750

Motor output

5,5kW / 7,5kW / 11,0kW
2900 or 3450 rpm [2-pol.]



Monitor and protect your pump and your process !

Electronic process monitoring -> RPR-Control



- Monitoring the filter fouling
- Dry running
- Overheating
- Overload

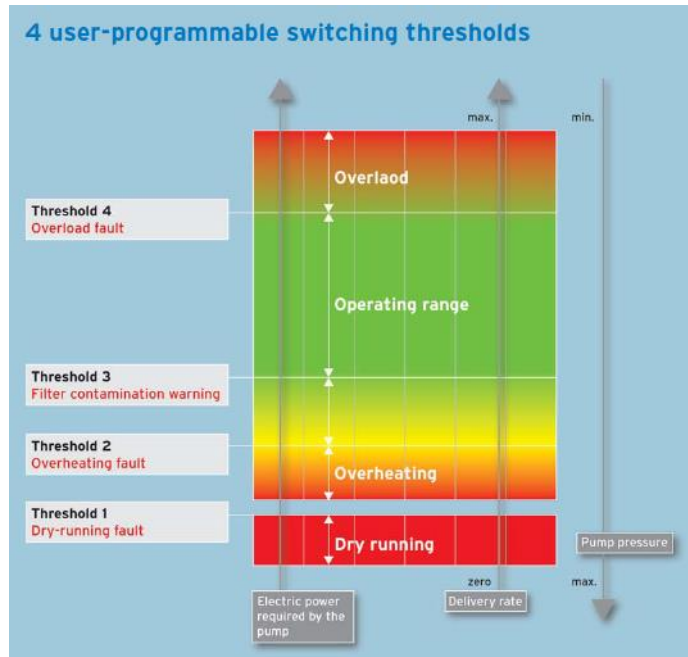

Subject to technical alterations !

