

G16

Smoke Density Monitor

Continuous smoke density monitoring

Advanced monitoring system for emission and process control



Maritime

 Green
Instruments



The G16 Smoke Density Monitor is designed for use in stacks on board vessels. The system provides the crew with precise combustion data for legal reporting requirements, reducing the risk of potential fines not complying with local regulations.

Continuous smoke density monitoring

Key features

- Ensures environmental compliance
- Simple installation – minimal footprint
- Robust design with low maintenance cost
- Configurable number of detectors per monitor
- Displays opacity (0-100%)
- Simple and fast on-site validation with audit module
- Low cost of ownership – no consumable parts
- Low energy consumption
- ATEX/IECEx version available
- US EPA compliant
- 36-month warranty
- Global service and support

Certificates



The G16 Smoke Density Monitor is an advanced monitoring system that measures the particles of smoke and dust in stacks. Smoke is generated by diesel engines, boilers, incinerators, etc. The system determines the level of particles in the smoke to provide precise combustion data for legal and financial reporting requirements. The G16 Smoke Density Monitor also ensures environmental compliance and measures the full range of opacity (0-100%). It is compact and simple to install in newbuilds and retrofits.

Reliable monitoring

The G16 Smoke Density Monitor is designed for installation in stacks on board vessels. The robust transceiver consists of

a solid green laser, an optical system, and electronics. To provide precise data, a light beam with specific spectral characteristics is projected across the space inside the stack. The amount of light reflected back to the instrument from an installed reflector is compared with the maximum possible return when there is nothing obstructing the beam. The strength of the return signal thus indicates whether smoke and dust or other particulate matters are present in the stack. This double-pass measurement method ensures a high level of performance and reliability.

Simple operation

The system includes an HMI module and is available with

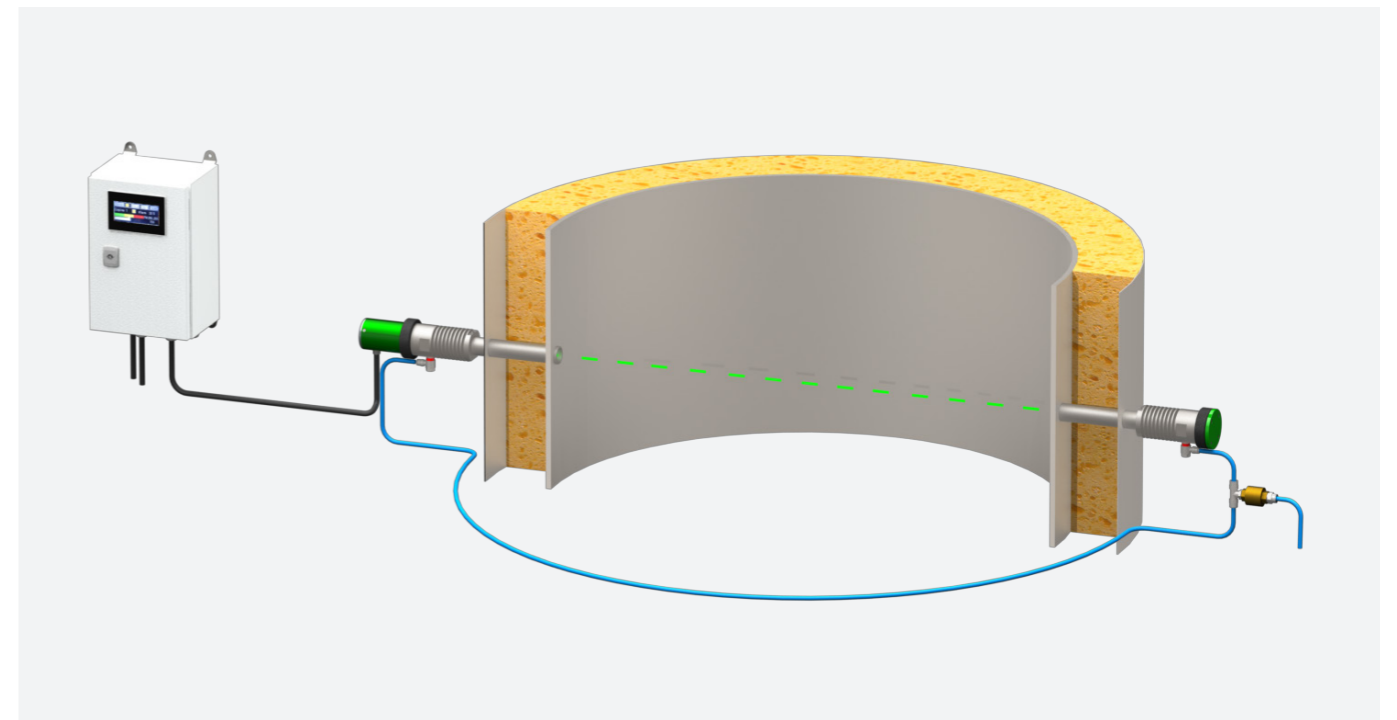

different interface options. The home screen provides an immediate overview of smoke and dust density inside the stack. This means the crew will be provided with precise combustion data, which they need to report for legal requirements. The opacity monitoring system provides multiple functions for control, graphic, and data logging and can be installed with an audit module for easy verification.

Low maintenance cost

The robust opacity monitoring system is designed to resist heat and vibrations and can be used in extreme environments in stacks on board vessels. It does not require much maintenance expect occasional cleaning of the lenses and in-situ calibration. The optical parts can be cleaned easily without the need for special tools, and the purge air system will keep the optical lenses clear of soot contamination.

ATEX/IECEx certified version

The G16 Smoke Density Monitor is available as an ATEX/IECEx certified version called G16 Ex. The G16 Ex is designed for use in hazardous areas.

Service, support, and warranty

The G16 Smoke Density Monitor is compact and simple to install. The detector's lens only requires occasional cleaning using a dry cloth, and calibration can easily

be carried out by a member of the crew. Green Instruments provides full service and support to ensure optimal operation throughout the entire product lifetime. The G16 Smoke Density Monitor comes with a 36-month warranty.

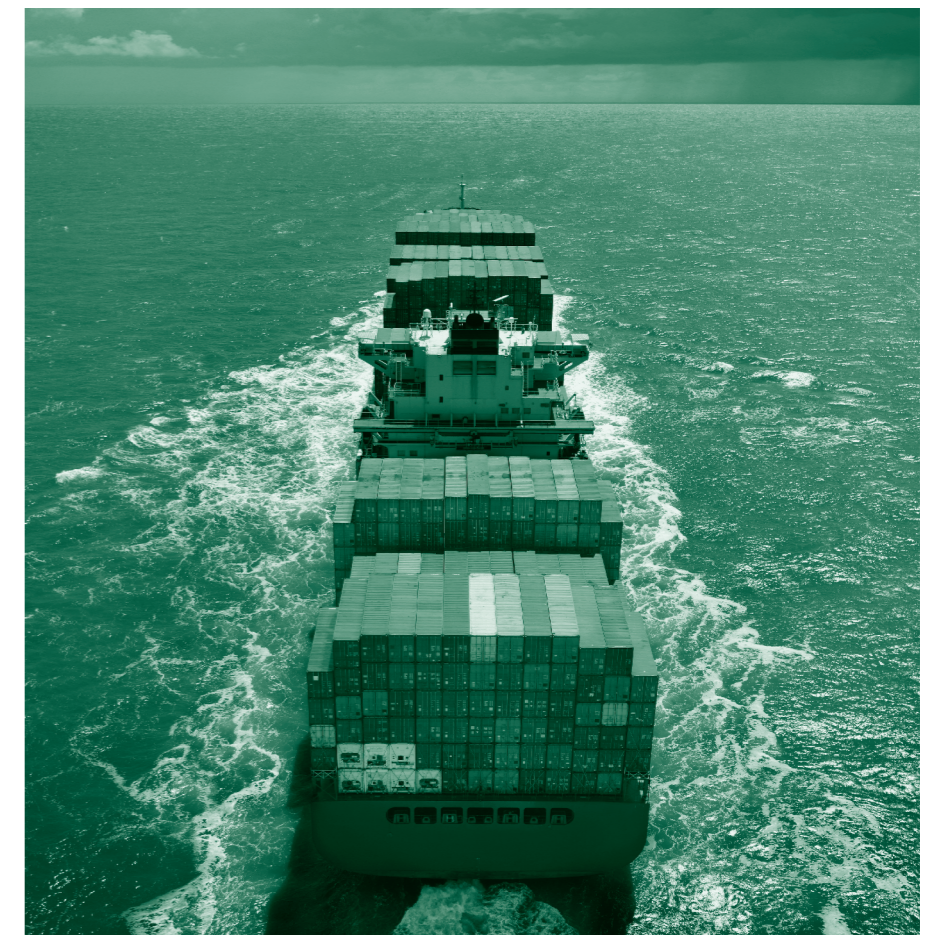

Specifications – G16

CONTROL AND MONITORING UNIT

Power supply

Standard	20 – 30 VDC - 2 A
Optional	100 – 240 VAC - 50/60 Hz - 1.4 A
Ambient temperature	0 – 55 °C

Communication

Analog output	2 x 4 - 20 mA max 500 Ω - active and linearized
Digital output	4 x alarm relays
Bus	Modbus TCP/IP
Alarm level	Alarm level is configurable Warning level is automatic set at 50 % of the alarm level
Alarm delay	Default 0 s / programmable (0 - 1800 s)

Material/enclosure

Enclosure	IP 65 steel box
-----------	-----------------

Dimensions/weight

Dimensions	300 x 200 x 150 mm
Weight	5.5 kg

TRANSCEIVER INCL. REFLECTOR AND AIR MODULE

Measuring range	0 – 100 % opacity
Measuring principle	Transmission dual pass
Flue gas temperature	Above dewpoint up to 400 °C
Flue gas pressure	-500 to +500 hPa
Ambient temperature	0 – 55 °C
Purge air supply	5 – 10 NLPM. Air quality to meet ISO 8573-1:2010 Class 3:3:3
Enclosure	IP 66 steel box
Dimensions/weight	OD 75 mm, length 220 mm / 1.8 kg
Scanning distance	1 – 15 m

ACCESSORIES AND OPTIONAL

Welding sockets	1" mild steel tubes
Brackets	Support and alignment brackets to support welding sockets
Audit module	Audit module and audit targets for easy on-site validation
Others	Sealing / purge air compressor Visualization, recorder, and data logging Ex version

Specifications subject to changes without notice

EUROPE

Green Instruments A/S

Erhvervsparken 29
9700 Brønderslev, Denmark
Tel: +45 96 45 45 00

sales@greeninstruments.com

AMERICA

Green Instruments USA, Inc.

6750 N. Andrews Avenue Suit 200
Fort Lauderdale, FL-33309, USA
Tel: +1 954 613 0400

usa@greeninstruments.com

ASIA

Green Instruments (S) Pte. Ltd.

4008 Ang Mo Kio Avenue 10
#01-09/10 Techplace I, Singapore 569625
Tel: +65 3100 0577

sales.sg@greeninstruments.com



For more information, please visit us at www.greeninstruments.com.