



# Brevini<sup>®</sup> Evolution<sup>™</sup> Series Hoisting Winches

The new Winch Series for Mobile and Industrial Markets



## Hoisting solutions

Nine sizes of winches with line pull from 1,5 tons to 16 tons at first layer, designed for cranes used in Mobile and Industrial market. The winches are equipped with High Speed Brevini<sup>®</sup> Hydraulic Motor and a wide range of controls ensure safety, avoid damage to the winch, the crane, and most importantly, people on job site.



# Brevini<sup>®</sup> Evolution<sup>™</sup> Series **Hoisting Winches**

The new Winch Series for Mobile and Industrial Markets





**BREVINI<sup>®</sup>**

*Motion Systems*

© 2022 Dana Limited. All rights reserved.

The product images and drawings shown are for illustration purposes only and may not be an exact representation of the product. We reserve the right to change or modify our product specifications, configurations, or dimensions at any time without notice.



## Brevini® Evolution™ Series Hoisting Winches

The brand new series of high-performance Brevini® Evolution™ Series winches for construction and material-handling vehicles, marine, off-shore and many other mobile or stationary applications are the result of years of experience in Engineering and Manufacturing of winches.

With 9 sizes available, BWE015, BWE025, BWE035, BWE055, BWE070, BWE085, BWE105, BWE125 and BWE160 which offer a lifting capacity from 1,5 ton to 16 ton (3,300 lbf to 35,200 lbf) we will enhance the product range and give us the opportunity to better serve our customers.

Brevini® Evolution™ Series Winches feature the Brevini® high-speed piston motor, fixed or variable displacement.

Introducing the nine piston motor technology as a standard option we are able to provide ideal balance and smooth control even at very low speed keeping high performance level. Electric motor are also available on request.

The new winch series has a strong modular design that makes the winch able to meet customer specification in terms of performances as well as customer needs in term of accessories.

For all sizes are available grooved drum made by the special groove profile which improve the spooling performances, rope capacity as well as rope lifetime.

A wide range of accessories are available to improve safety and control of all winch function.

For all sizes are available pressure roller, hydraulic or electric limit switch as last safety wraps indicator, electric or hydraulic rotary limit switch as minimum and maximum rope capacity indicator, speed sensor, torque/overload sensor to have better control on spooling and other winch operation.

For all sizes is available the “Personnel Lifting” version due to a secondary brake directly connected to the drum which assure safety and control in all working condition.

Other accessories like rope, hook and shackle are available to meet customer requirements.

The new winch series are suitable for marine environment due to many technical features which makes the winch the perfect solution for this application, drum and frame in steel, pressure roller made in stainless steel, marine painting.

The winches are designed to meet safety certification standards for major international organizations governing these applications. Brevini® winches are suitable for ambient working Temperature between -20°C to +40°C. In case of ambient working temperature lower than -20°C has to be approved by Engineering.

Different working condition on request.

More than 40 years of winches experience makes this new winch series an innovative and high-performance products ideal for the new generation of machine.



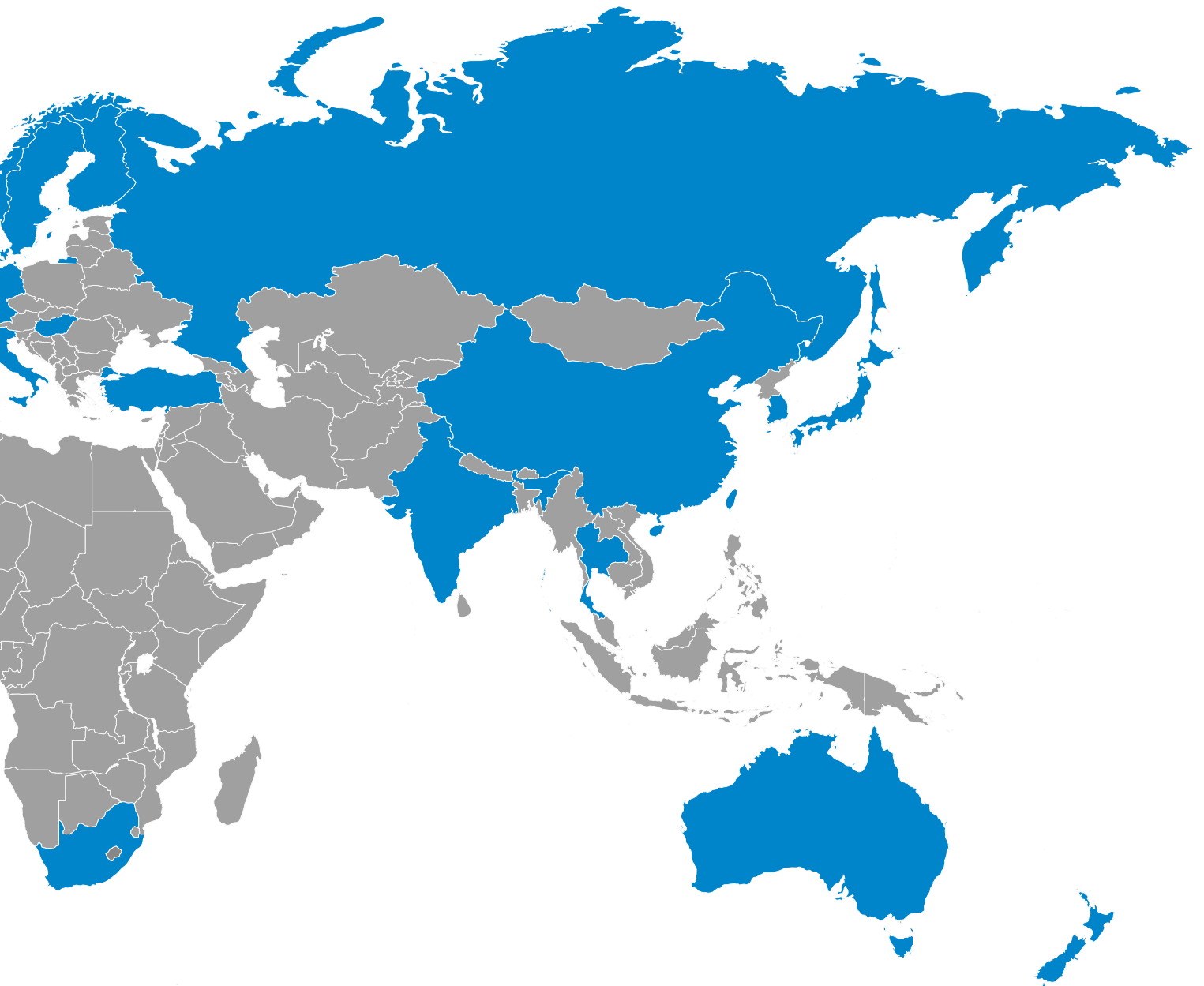



<b>A</b>	Main Mobile Applications	<b>A8</b>
	Main Industrial Applications	<b>A9</b>
	F.E.M. Tables	<b>A10</b>
	What We Supply	<b>A11</b>
	Winches Designation	<b>A12</b>
	Rope Description	<b>A14</b>
	Rope Accessories Description	<b>A15</b>
	Symbology	<b>A16</b>
	BWE Series Winch Family	<b>A17</b>
<b>Technical Data and Dimensional</b>		
<b>W015</b>	BWE015	<b>.1</b>
	Dimensions	<b>.2</b>
	Performance Tables	<b>.5</b>
	Performance Graphs	<b>.7</b>
<b>W025</b>	BWE025	<b>.1</b>
	Dimensions	<b>.2</b>
	Performance Tables	<b>.5</b>
	Performance Graphs	<b>.7</b>
<b>W035</b>	BWE035	<b>.1</b>
	Dimensions	<b>.2</b>
	Performance Tables	<b>.5</b>
	Performance Graphs	<b>.7</b>
<b>W055</b>	BWE055	<b>.1</b>
	Dimensions	<b>.2</b>
	Performance Tables	<b>.5</b>
	Performance Graphs	<b>.7</b>
<b>W070</b>	BWE070	<b>.1</b>
	Dimensions	<b>.2</b>
	Performance Tables	<b>.5</b>
	Performance Graphs	<b>.7</b>





<b>W085</b>	BWE085	.1
	Dimensions	.2
	Performance Tables	.5
	Performance Graphs	.7
<b>W105</b>	BWE105	.1
	Dimensions	.2
	Performance Tables	.5
	Performance Graphs	.7
<b>W125</b>	BWE125	.1
	Dimensions	.2
	Performance Tables	.5
	Performance Graphs	.7
<b>W160</b>	BWE160	.1
	Dimensions	.2
	Performance Tables	.4
	Performance Graphs	.7
<b>B</b>	Accessories	<b>B2</b>
	Torque Sensor	<b>B4</b>
	Universal Input Flange 00	<b>B5</b>
	Control Valve	<b>B10</b>
	Certifications	<b>B12</b>
	Installation Advice	<b>B13</b>
	Lubrication	<b>B14</b>
	Selection Winch Technical Sheet	<b>B17</b>

Dana has introduced the introductive index, page symbols and bookmarks, which allow you to arrive and print the relevant section faster.

Clicking the Dana logo at the bottom page, you'll come back to the index.

# MAIN MOBILE APPLICATIONS

**Rough-Terrain Crane**



**Crawler Telescopic boom Crane**



**Piling Rig**



**All Terrain Crane**



**Stacker and Reclaimer**



**Off-Shore Cranes**



**Drill Rig**



**Marine Cranes**



**Harbor Crane**

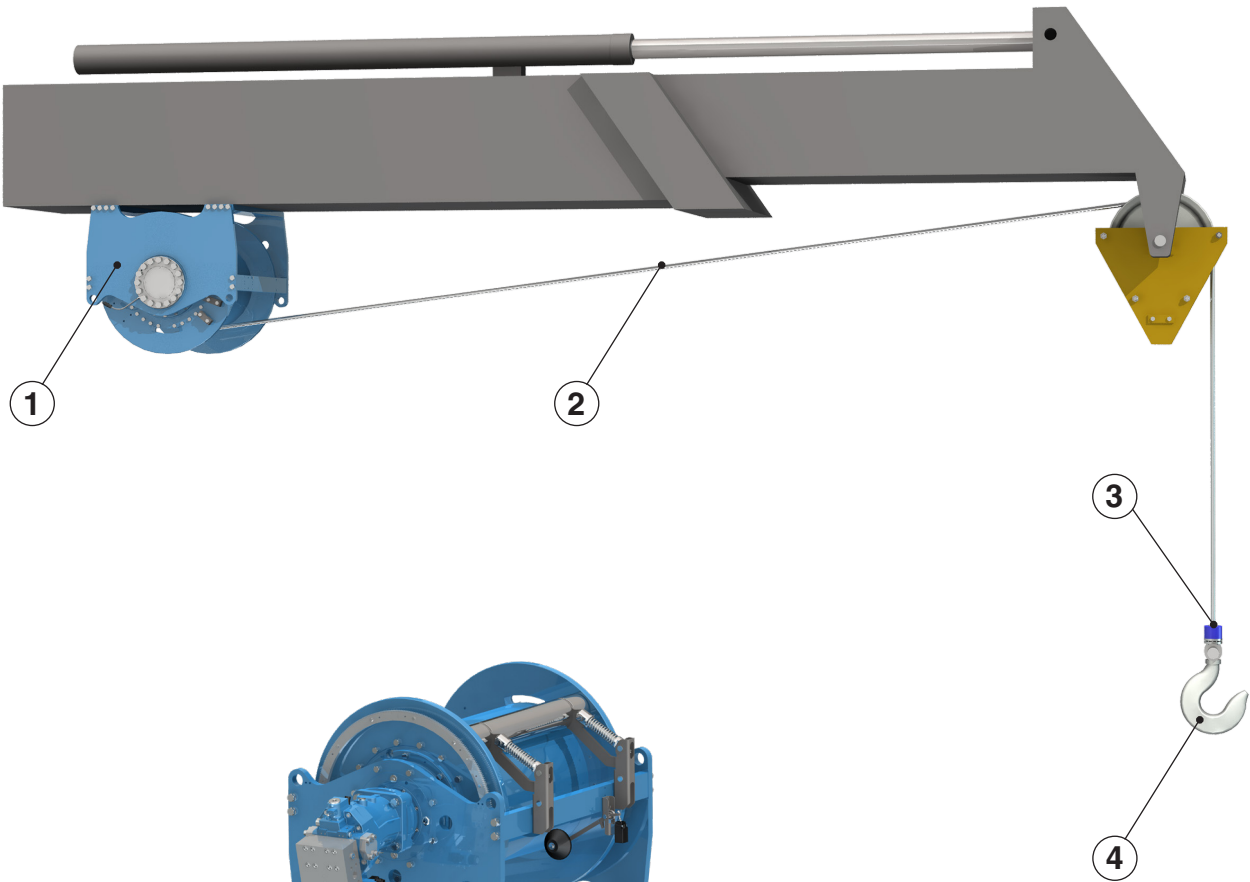

Table N° 1

Crane type classification guide		According to FEM section I, 3rd edition, Table T.2.1.3.5	
Type of crane	Type of duty	Type of mechanism	
		Hoisting	Lifting
Erection cranes		M2 - M3	M1 - M2
Loading bridge cranes	Hook duty	M5 - M6	-
	Grab or magnet duty	M7 - M8	-
Workshop cranes		M6	-
Overhead travelling cranes, pig-breaking cranes, scrapyards cranes	Grab or magnet duty	M8	-
Bridge cranes for unloading, bridge cranes for containers Other bridge cranes (with crab, and/or slewing jib)	a) Hook or spreader duty	M6 - M7	M3 - M4
	b) Hook duty	M4 - M5	-
Bridge cranes for unloading, bridge cranes (with crab, and/ or slewing jib)	Grab or magnet duty	M8	M3 - M4
Dry dock cranes, shipyard jib cranes, jib ceanes for dismantling	Hook duty	M5 - M6	M4 - M5
Dockside cranes (slewing, on ganty, etc.), floating cranes and pontoon derricks	Hook duty	M6 - M7	M5 - M6
	Grab or magnet duty	M7 - M8	M6 - M7
Floating cranes and pontoon derricks for very heavy loads (usually greater than 100 t)	Hook duty	M3 - M4	M3 - M4
Deck cranes	Hook duty	M4	M3 - M4
	Grab or magnet duty	M5 - M6	M3 - M4
Tower cranes for building		M4	M4
Derricks		M2 - M3	M1 - M2
Railway cranes allowed to run in a train		M3 - M4	M2 - M3
Mobile cranes	Hook duty	M3 - M4	M2 - M3

Table N° 2

Classes of utilization (Table T.2.1.3.4.)		Class of utilization						
		T2	T3	T4	T5	T6	T7	T8
		400 < T2 800	800 < T3 1600	1600 < T4 3200	3200 < T5 6300	6300 < T6 12500	12500 < T7 25000	25000 < T8 50000
L1	0 > Km 0.125		M2	M3	M4	M5	M6	M7
L2	0.125 > Km 0.250	M2	M3	M4	M5	M6	M7	M8
L3	0.250 > Km 0.500	M3	M4	M5	M6	M7	M8	-
L4	0.500 > Km 1000	M4	M5	M6	M7	M8	-	-



1 Winch

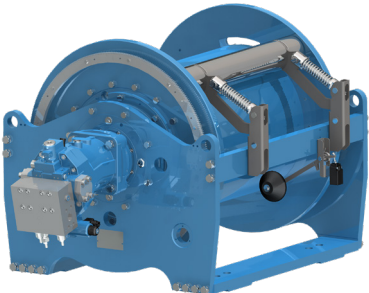

2 Rope



3 Shackle



4 Hook



# WINCHES DESIGNATION

**BWE085**    **SD24**    **01**    **\_s**    **49.4**    **APV085**    **\_0**    **P**

Size	SD24 Drum Configuration SD24 Rope Diameter	Drum Rotation Sense	Sprag Clutch	Ratio	APV085 Motor APV085 Displacement	Overcenter valve	Pressure Roller
------	---	---------------------	--------------	-------	-------------------------------------	------------------	-----------------

BWE015  
BWE025  
BWE035  
BWE055  
BWE070  
BWE085  
BWE105  
BWE125  
BWE160

**SDØ**  
Smooth Drum

**GDØLL** <sup>(1)</sup>  
Special Grooved Left

**GDØLR** <sup>(2)</sup>  
Special Grooved Right

**01** \*  
Clock Wise

**02** \*  
Counter Clock Wise

**\_s**  
w/ Sprag clutch

-  
No Sprag Clutch

49.4

81.0

**APV**  
Axial Pistons Variable

**APF**  
Axial Pistons Fixed

**ORB**  
Orbital

**00**  
Universal Input

**FI** <sup>(2)</sup>  
Female Input

**MI** <sup>(2)</sup>  
Male Input

**ELM** <sup>(2)</sup>  
Electric Motor

**\_0**  
NO Overcenter

**\_1**  
1 Overcenter

**\_2**  
2 Overcenter

**P**  
Present

-  
None

\* From motor side view  
<sup>(1)</sup> Available with sense of rotation counter clockwise 02 only  
<sup>(2)</sup> Available on request with sense of rotation clockwise 01 only

EL	RE	TS	E1	AR	LP	Others	L606	Q601
----	----	----	----	----	----	--------	------	------

Limit Switch	Rotary limit Switch	Torque Sensor	Encoder	Rope Mounted	Lifting of Personnel Winch	Other	Drum Length	Certification
--------------	---------------------	---------------	---------	--------------	----------------------------	-------	-------------	---------------

**EL**  
Electric Switch  
**HY**<sup>(3)</sup>  
Hydraulic Switch  
-  
None

**RS**  
Rotary Shaft  
(Predisposition for Rotary Switch or Encoder)

**RE**  
Rotary Electric Switch

**RH**  
Rotary Hydraulic Switch  
-  
None

**TS**<sup>(3)(4)</sup>  
Torque Sensor  
-  
None

**E1**  
Proximity Sensor

**E2**  
Absolute Encoder

**E3**  
Speed sensor on the motor  
-  
None

**R**  
Rope  
**AR**  
Rope with Accessories  
-  
None

**LP**  
Lifting of Personnel  
-  
None

**Other Characteristics**  
-  
None

**L606**  
Drum Length [mm]

**Qxxx**  
Certification  
-  
None

<sup>(3)</sup> Available with single overcenter valve only (pag.B10)

<sup>(4)</sup> Not available for lifting of personnel application

ROPE	18x7	D14x100	RL	G	CT	NoR	2160	A02	DNV GL
------	------	---------	----	---	----	-----	------	-----	--------

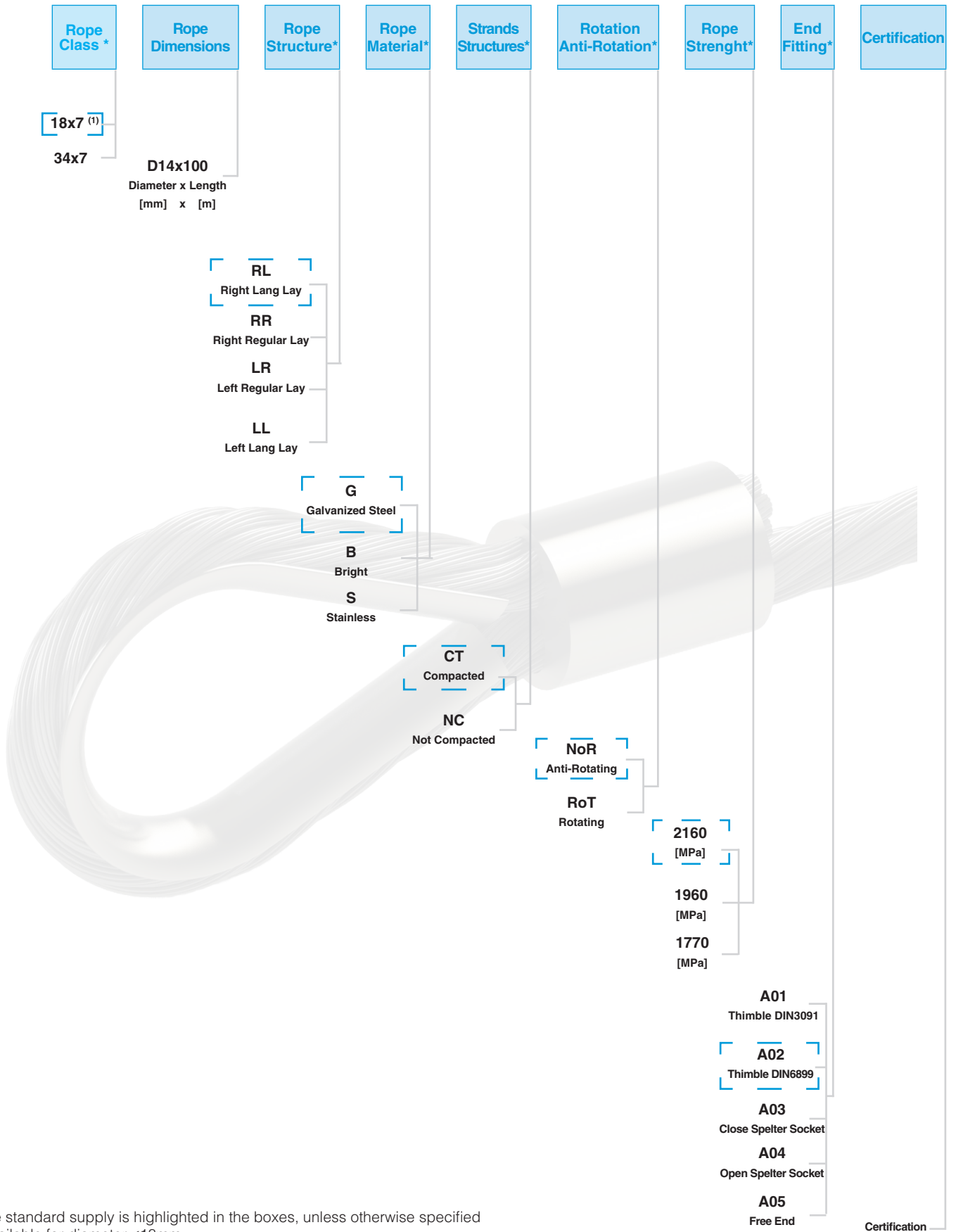

\* The standard supply is highlighted in the boxes, unless otherwise specified  
 (1) Available for diameter ≤18mm



# ROPE ACCESSORIES DESCRIPTION



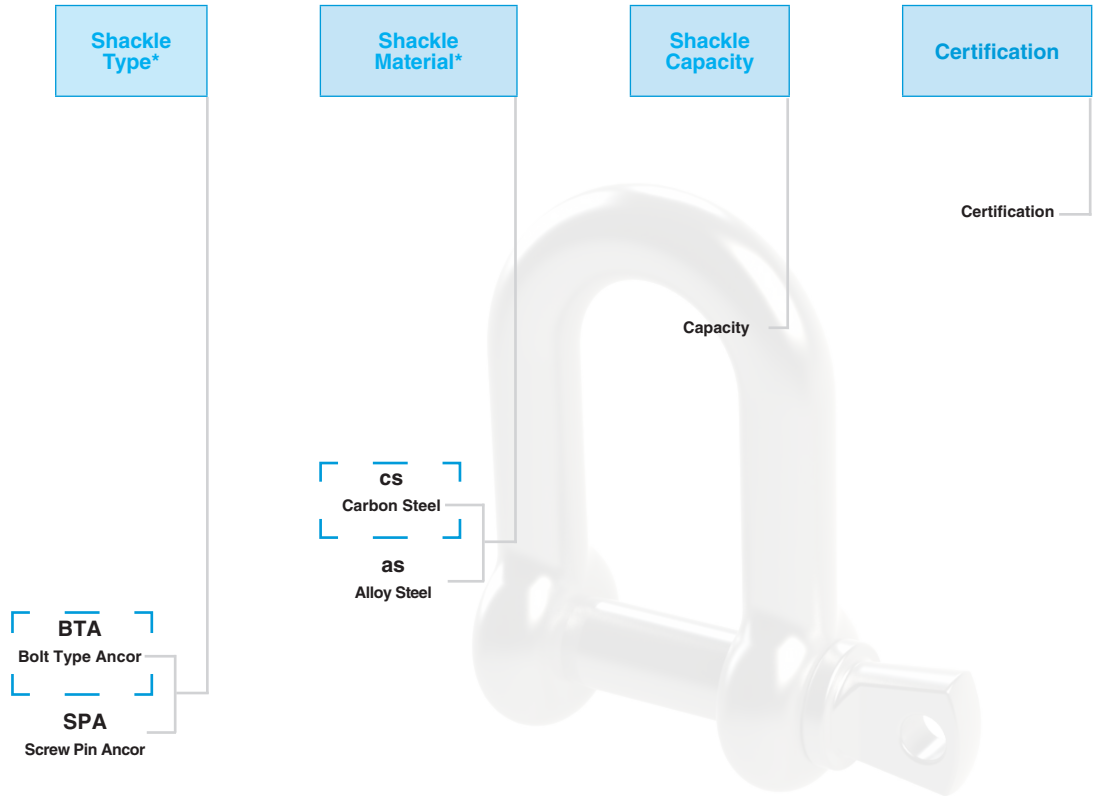



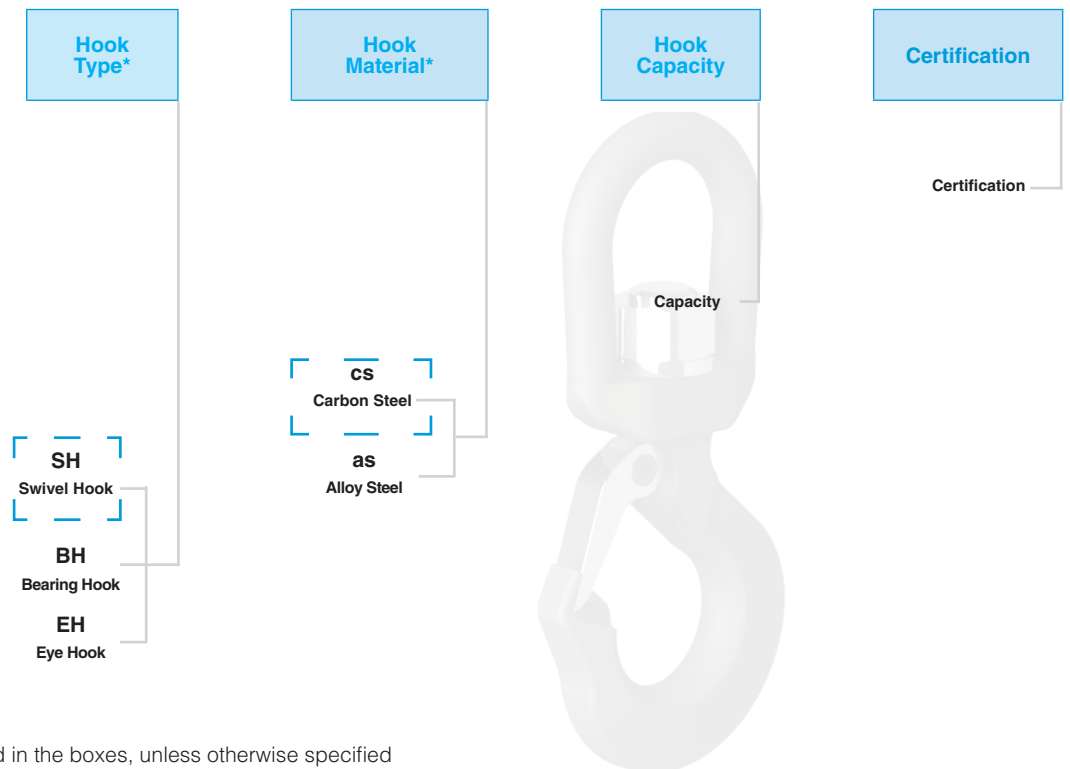

<b>SHACKLE</b>		<b>BTA</b>		<b>CS</b>		<b>3Ton</b>		<b>DNV GL</b>
----------------	--	------------	--	-----------	--	-------------	--	---------------



<b>HOOK</b>		<b>SH</b>		<b>CS</b>		<b>3Ton</b>		<b>ABS</b>
-------------	--	-----------	--	-----------	--	-------------	--	------------



\* The standard supply is highlighted in the boxes, unless otherwise specified

Description	Units		Symbol
	SI	USC	
Minimum Geometrical Displacement	cm <sup>3</sup> /rev	in <sup>3</sup> /rev	<b>Vg<sub>min</sub></b>
Maximum Geometrical Displacement	cm <sup>3</sup> /rev	in <sup>3</sup> /rev	<b>Vg<sub>max</sub></b>
Speed	rpm	rpm	<b>n<sub>2</sub></b>
Filling Plug	-	-	
Oil Level Plug	-	-	
Magnetic Drain Plug	-	-	
Motor Drain Plug	-	-	<b>DR</b>
Brake Filling Plug	-	-	
Brake Oil Level Plug	-	-	
Brake Drain Plug	-	-	
Brake Releasing Plug	-	-	
Motor Service Ports	-	-	
	-	-	
Drum Rotation	-	-	



**BREVINI**<sup>®</sup>

*Motion Systems*

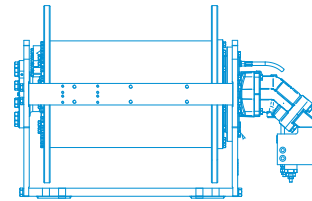

Size	Line Pull at first Layer [kg]	Line Pull at first Layer [lbf]
<b>BWE015</b>	1.500	3.300
<b>BWE025</b>	2.500	5.500
<b>BWE035</b>	3.500	7.700
<b>BWE055</b>	5.500	12.100
<b>BWE070</b>	7.000	15.400
<b>BWE085</b>	8.500	18.700
<b>BWE105</b>	10.500	23.100
<b>BWE125</b>	12.500	27.500
<b>BWE160</b>	16.000	35.200





**BREVINI<sup>®</sup>**

*Motion Systems*

**Line Pull at first Layer up to:**  
**1.500 [kg]**  
**3.300 [lbf]**

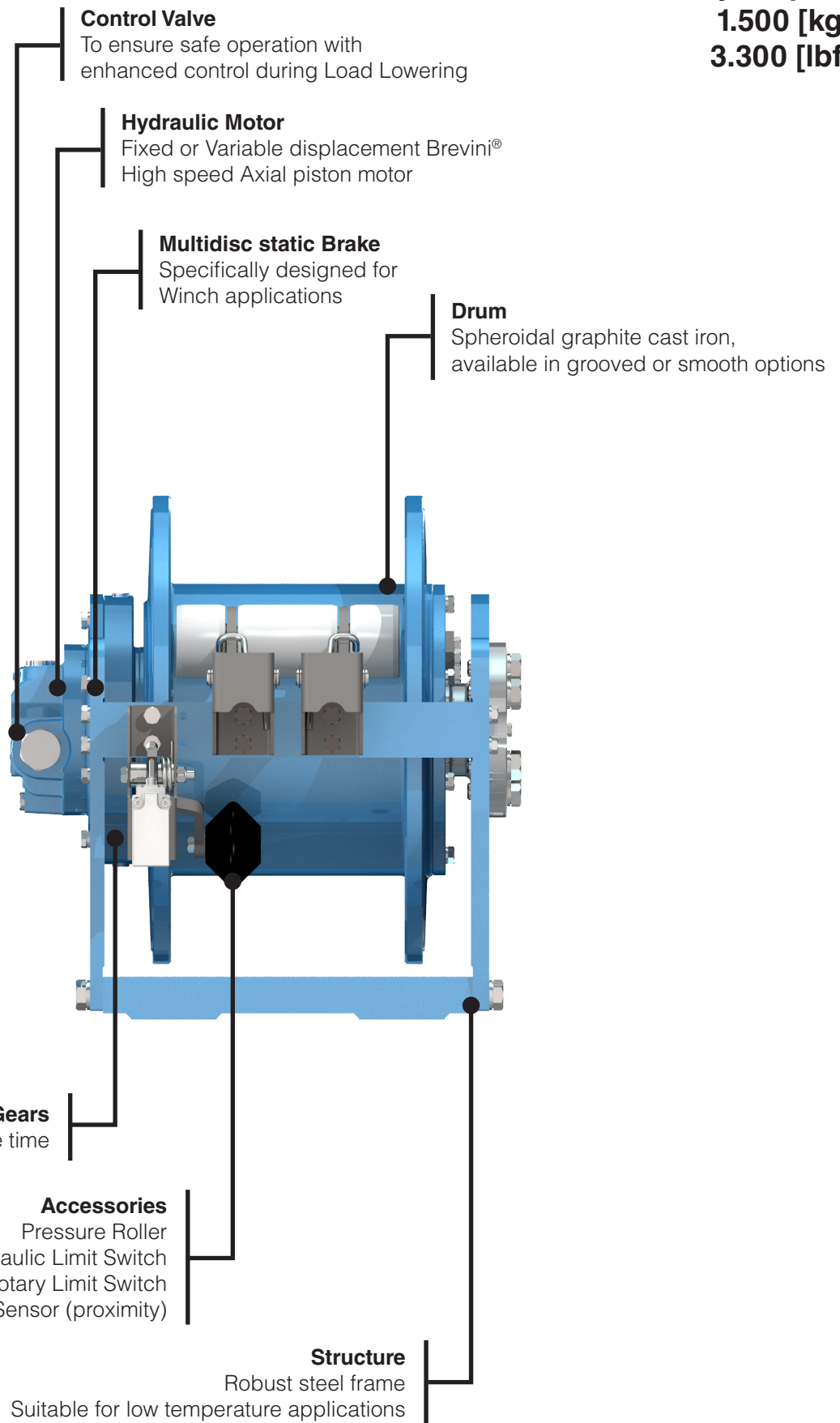

Brevini® Hydraulic Motor

	Motor type	Displacement	L
Fixed Displacement	B5VA021 <sup>(1)</sup>	21 cm <sup>3</sup> /rev [1.28 in <sup>3</sup> /rev]	64.0 mm [2.519 in]
Fixed Displacement	BRZV160 <sup>(1)</sup>	160 cm <sup>3</sup> /rev [9.76 in <sup>3</sup> /rev]	89.5 mm [3.523 in]
With NO Motor	Universal Input Flange 00	-	22.5 mm [0.886 in]

Winch - standard <sup>(2)</sup>

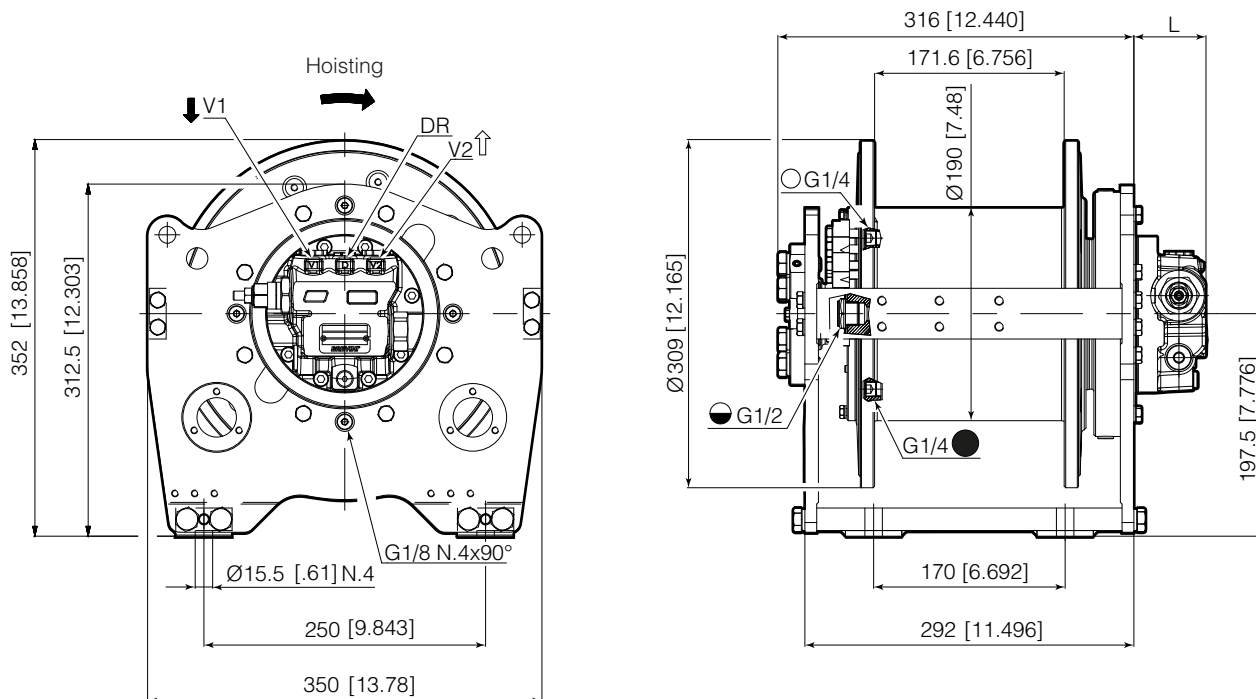

Winch - extended drum <sup>(2)</sup>

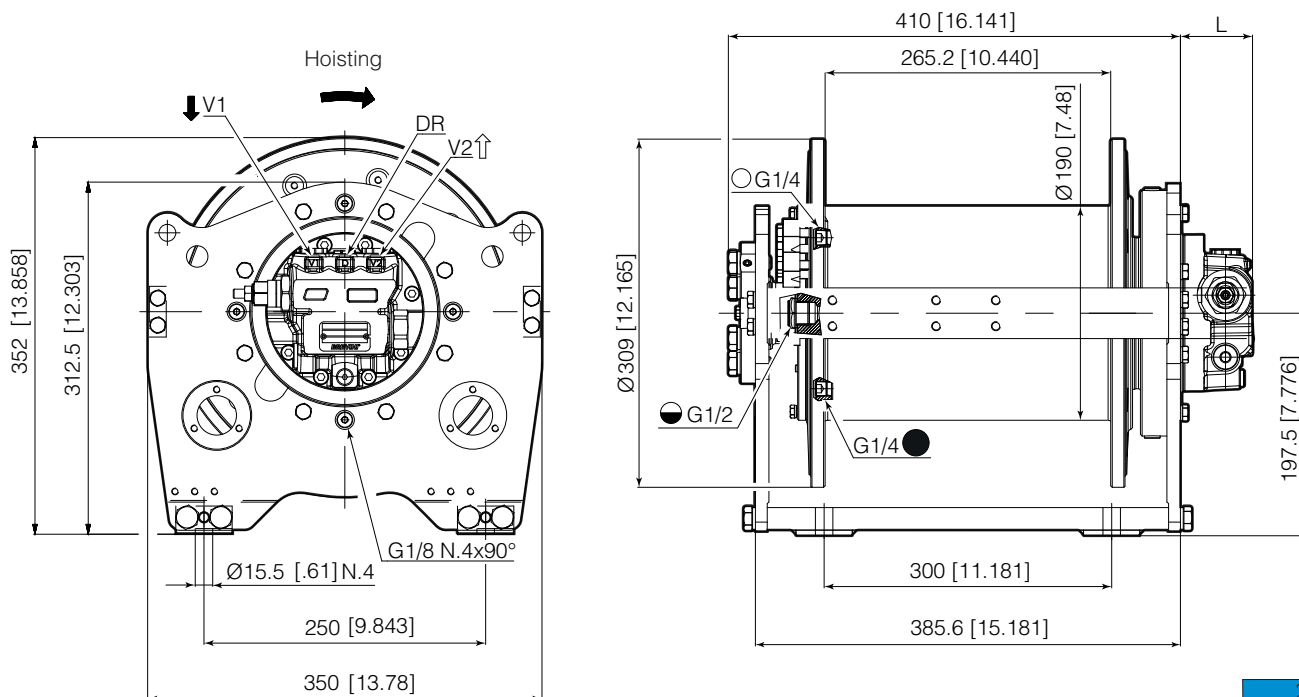

<sup>(1)</sup> As Standard with single overcenter valve, double overcenter valve available on request.

<sup>(2)</sup> Catalogue dimensions only for reference, see dimensional drawing for detailed information

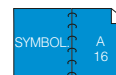

Brevini® Hydraulic Motor for Lifting of Personnel Winches

	Motor type	Displacement	L
Fixed Displacement	B5VA021 <sup>(1)</sup>	21 cm <sup>3</sup> /rev [1.28 in <sup>3</sup> /rev]	64.0 mm [2.519 in]
Fixed Displacement	BRZV160 <sup>(1)</sup>	160 cm <sup>3</sup> /rev [9.76 in <sup>3</sup> /rev]	89.5 mm [3.523 in]
With NO Motor	Universal Input Flange 00	-	22.5 mm [0.886 in]

Lifting of Personnel Winch - standard <sup>(3)</sup>

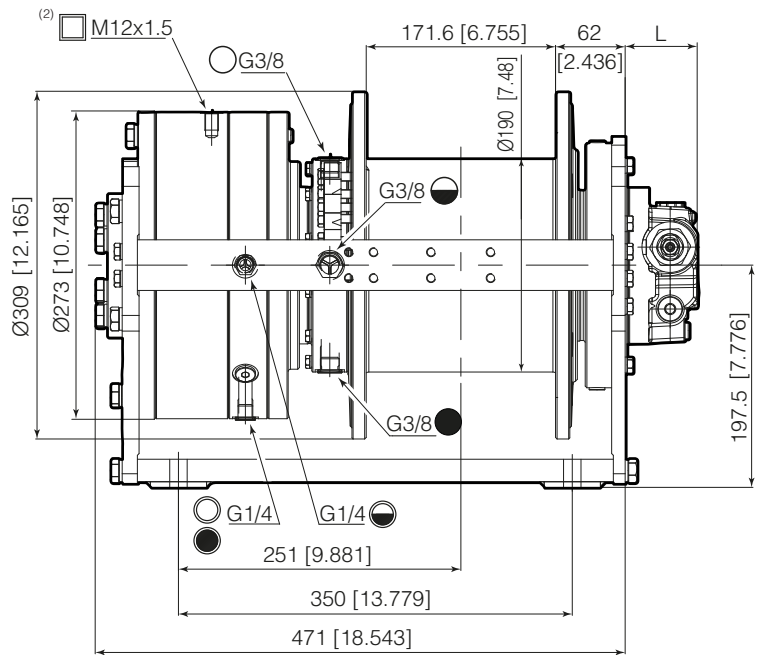
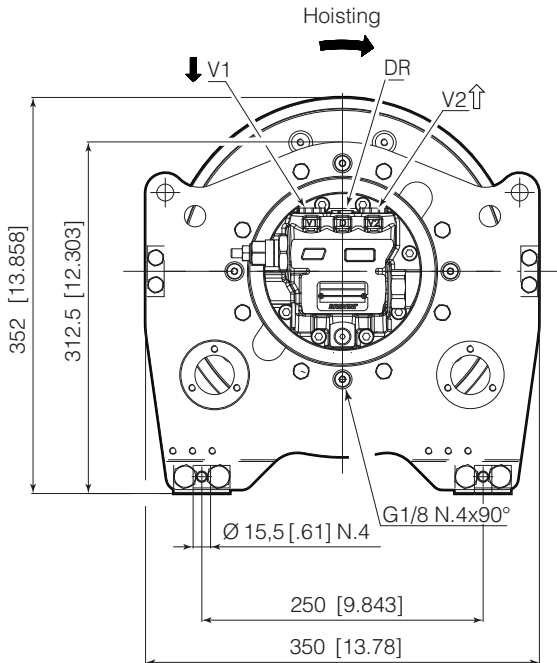

Lifting of Personnel Winch - extended drum <sup>(3)</sup>

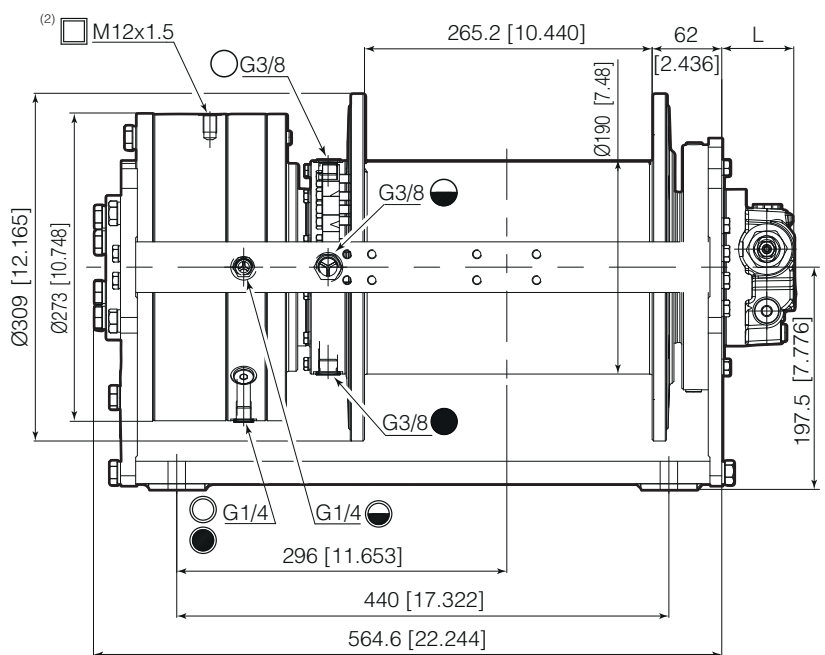
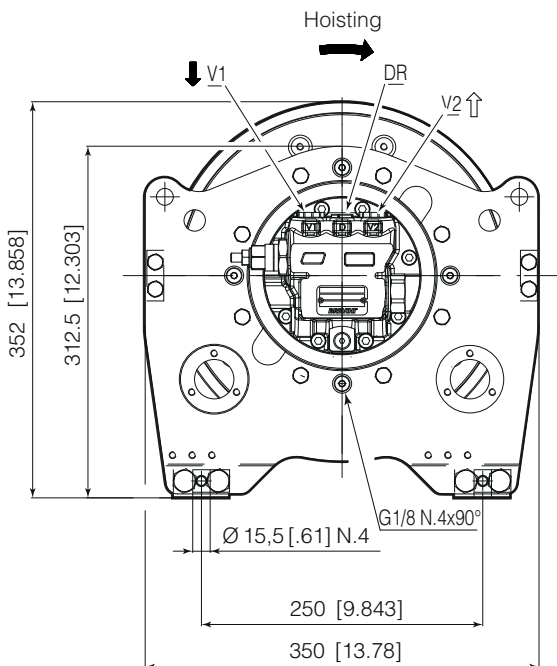

<sup>(1)</sup> As Standard with single overcenter valve, double overcenter valve available on request.

<sup>(2)</sup> Lifting of personnel brake release pressure (Release/Max) 27/315 bar [392/4570 psi]

<sup>(3)</sup> Catalogue dimensions only for reference, see dimensional drawing for detailed information



### Motor Drum Winch

Available on request .

- with or without motor
- smooth or grooved drum
- customized drum length
- different rope diameter

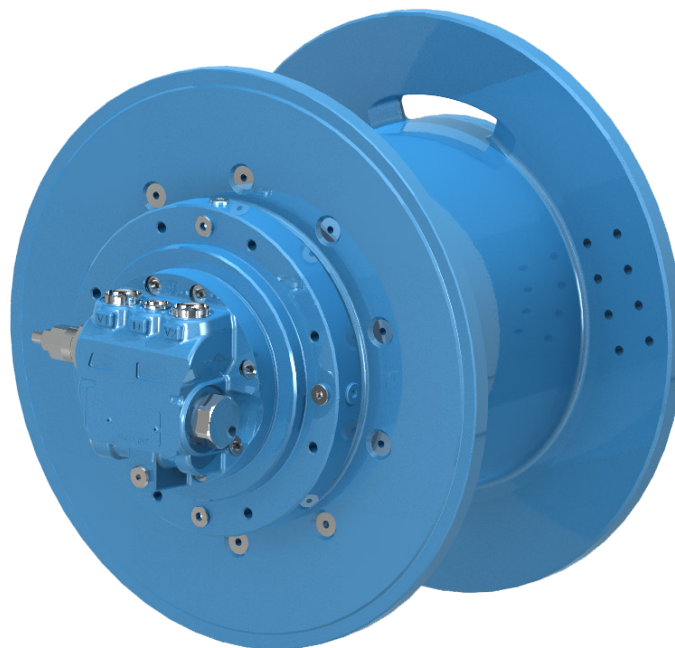

### Our Standard Configurations

<b>Hydraulic Motor Fixed Displacement</b>	<b>B5VA021</b>	21 [cm <sup>3</sup> /rev]	1.28 [in <sup>3</sup> /rev]
	<b>BRZV160</b>	160 [cm <sup>3</sup> /rev]	9.75 [in <sup>3</sup> /rev]
<b>Ratio</b>		19.1	
		3.95	
<b>Drum</b>	<b>standard</b>	Smooth Drum Special Grooved Drum <sup>(1)</sup>	
	<b>extended</b>	Smooth Drum Special Grooved Drum <sup>(1)</sup>	
<b>Rope</b>		Ø 8 [mm] Ø 10 [mm] Ø 12 [mm]	Ø 0.31 [in] Ø 0.39 [in] Ø 0.47 [in]

<sup>(1)</sup> Left hand grooving as Standard only with rope diameter Ø 10 mm [0.39 in]. Right hand grooving on request. Other rope diameter available on request.



## International System of Units: SI

BWE015-SD10..-01-19.1-APF021

Working layer			1	2	3	4	5	6	
			<b>Storage length</b>						
Line pull	[kg]		1500	1380	1280	1190	1120	-	
Rope speed	[m/min]		73	79	86	92	98	-	
Rope length	[m]		10	20	33	45	59	73	
Brevini® Motor	B5VA021		Advised rope diameter		10	[mm]			
Starting lifting pressure	320	[bar]	Oil fill/drain plug		G1/4	T			
Operating pressure	270	[bar]	Lifting / Lowering port		G1/2	V1 / V2			
Operating oil flow at the motor	50	[l/min]	Motor drain port		G1/4	DR			
Minimum oil flow at the motor	5.0	[l/min]	Static braking torque <sup>(1)</sup>		180	[Nm]			
Gear ratio	19.1	[i]	Brake release pressure (Release / Max)		34 / 350	[bar]			
Winch mechanisms classification in agreement with F.E.M. (1.001) (Third edition revised on 01.10.1998)							M5 (T5-L2)	n <sub>2</sub> =15 [rpm]	

		Weight [kg]		Oil [l]	
		Cargo	LoP	Cargo	LoP
<b>BWE015/B5VA021</b>	Standard	76	127	0.85	1.5
	Extended drum	84	135	1.75	2.4

## United States Customary Units: USC

BWE015-SD10..-01-19.1-APF021

Working layer			1	2	3	4	5	6	
			<b>Storage length</b>						
Line pull	[lbf]		3300	3050	2830	2630	2470	-	
Rope speed	[fpm]		241	262	282	303	324	-	
Rope length	[ft]		34	68	108	148	194	239	
Brevini® Motor	B5VA021		Advised rope diameter		0.39	[in]			
Starting lifting pressure	4640	[psi]	Oil fill/drain plug		G1/4	[gal]			
Operating pressure	3870	[psi]	Lifting / Lowering port		G1/2	V1 / V2			
Operating oil flow at the motor	13	[gpm]	Motor drain port		G1/4	DR			
Minimum oil flow at the motor	1.32	[gpm]	Static braking torque <sup>(1)</sup>		132	[ft·lbf]			
Gear ratio	19.1	[i]	Brake release pressure (Release / Max)		495 / 5080	[psi]			
Winch mechanisms classification in agreement with F.E.M. (1.001) (Third edition revised on 01.10.1998)							M5 (T5-L2)	n <sub>2</sub> =15 [rpm]	

		Weight [lbs]		Oil [gal]	
		Cargo	LoP	Cargo	LoP
<b>BWE015/B5VA021</b>	Standard	168	280	0.22	0.40
	Extended drum	185	298	0.46	0.63

**Note:**

- For safety reasons always keep at least 3 wraps of rope wrapped on the drum.
- Technical features may change with no previous notice from the manufacturer.
- The MBL of the Rope must be verified according to the requested Safety Factors.
- All data shown in this page are ONLY FOR INFORMATION. The actual data will be issued according to Customer application and Duty Cycle.

<sup>(1)</sup> Static braking torque does not affect the winch maximum static line pull which must be considered 125% of the nominal line pull at first layer.

## Line pull for Certified Winch Version: SI

Rope Diameter	Line Pull (according to DNVGL) [kg]				Line Pull (according to ABS) [kg]			
	Cargo Winch		Lifting of Personnell Winch		Cargo Winch		Lifting of Personnell Winch	
	Last Layer	First Layer	Last Layer	First Layer	Last Layer	First Layer	Last Layer	First Layer
Ø 8 [mm]	862 (5) <sup>(1)</sup>	1100	313 (5) <sup>(1)</sup>	400	862 (5) <sup>(1)</sup>	1100	392 (5) <sup>(1)</sup>	500
Ø 10 [mm]	1035 (4) <sup>(1)</sup>	1300	318 (4) <sup>(1)</sup>	400	955 (4) <sup>(1)</sup>	1200	398 (4) <sup>(1)</sup>	500
Ø 12 [mm]	1081 (3) <sup>(1)</sup>	1300	333 (3) <sup>(1)</sup>	400	998 (3) <sup>(1)</sup>	1200	416 (3) <sup>(1)</sup>	500

## Line pull for Certified Winch Version: USC

Rope Diameter	Line Pull (according to DNVGL) [lbf]				Line Pull (according to ABS) [lbf]			
	Cargo Winch		Lifting of Personnell Winch		Cargo Winch		Lifting of Personnell Winch	
	Last Layer	First Layer	Last Layer	First Layer	Last Layer	First Layer	Last Layer	First Layer
Ø 0.31 [in]	1900 (5) <sup>(1)</sup>	2445	690 (5) <sup>(1)</sup>	890	1900 (5) <sup>(1)</sup>	2445	864 (5) <sup>(1)</sup>	1112
Ø 0.39 [in]	2281 (4) <sup>(1)</sup>	2890	701 (4) <sup>(1)</sup>	890	2105 (4) <sup>(1)</sup>	2667	877 (4) <sup>(1)</sup>	1112
Ø 0.47 [in]	2383 (3) <sup>(1)</sup>	2890	734 (3) <sup>(1)</sup>	890	2200 (3) <sup>(1)</sup>	2667	917 (3) <sup>(1)</sup>	1112

The line pull listed above are just for reference, for this application is strongly recommended to fill up the Winch Application Data Form available at the end of this catalogue and consult the Dana area contact person for final selection and validation.

## Other Ropes available - standard

Working layer			1	2	3	4	5	6
Rope Diameter Ø 8 [mm]	Rope length	[m]	12	25	40	55	71	88
Rope Diameter Ø 12 [mm]	Rope length	[m]	8	17	28	38	-	-

Working layer			1	2	3	4	5	6
Rope Diameter Ø 0,31 [in]	Rope length	[ft]	42	84	132	181	234	288
Rope Diameter Ø 0,47 [in]	Rope length	[ft]	28	57	92	126	-	-

Last indicated Layer is intended only as Storage

## Other Ropes available - extended

Working layer			1	2	3	4	5	6
Rope Diameter Ø 8 [mm]	Rope length	[m]	19	40	62	86	111	137
Rope Diameter Ø 10 [mm]	Rope length	[m]	16	32	51	70	92	114
Rope Diameter Ø 12 [mm]	Rope length	[m]	13	27	43	60	-	-

Working layer			1	2	3	4	5	6
Rope Diameter Ø 0,31 [in]	Rope length	[ft]	65	132	206	282	365	450
Rope Diameter Ø 0,39 [in]	Rope length	[ft]	52	107	168	232	302	374
Rope Diameter Ø 0,47 [in]	Rope length	[ft]	44	90	143	198	-	-

Last indicated Layer is intended only as Storage

<sup>(1)</sup> Last working layer

Axial Piston Motor Fixed Displacement

Maximum Line pull at first layer

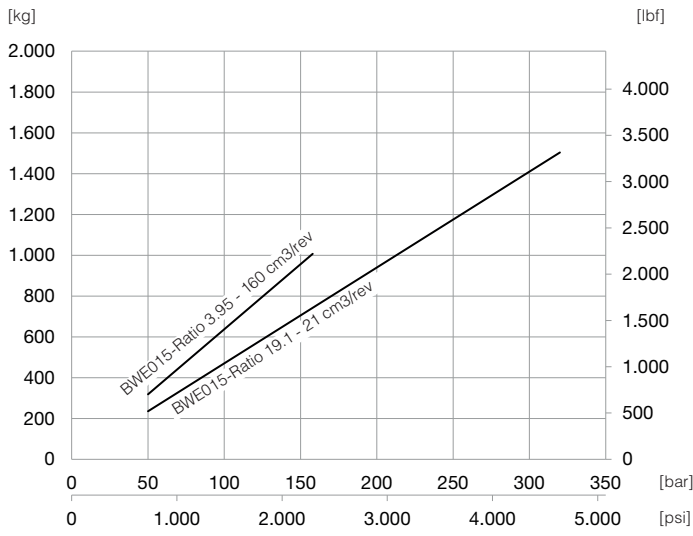

Maximum Speed at first layer

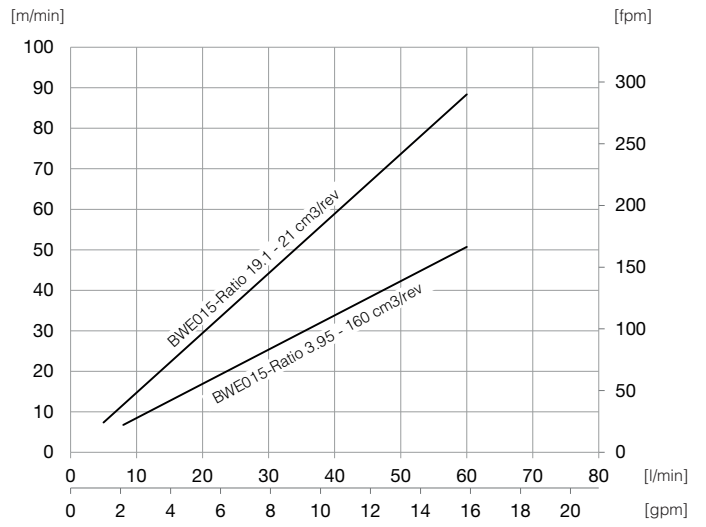

**Note:**

- All data shown in this page are ONLY FOR INFORMATION. The actual data will be issued according to Customer application and Duty Cycle.



**BREVINI<sup>®</sup>**

*Motion Systems*

**Line Pull at first Layer up to:**  
**2.500 [kg]**  
**5.500 [lbf]**

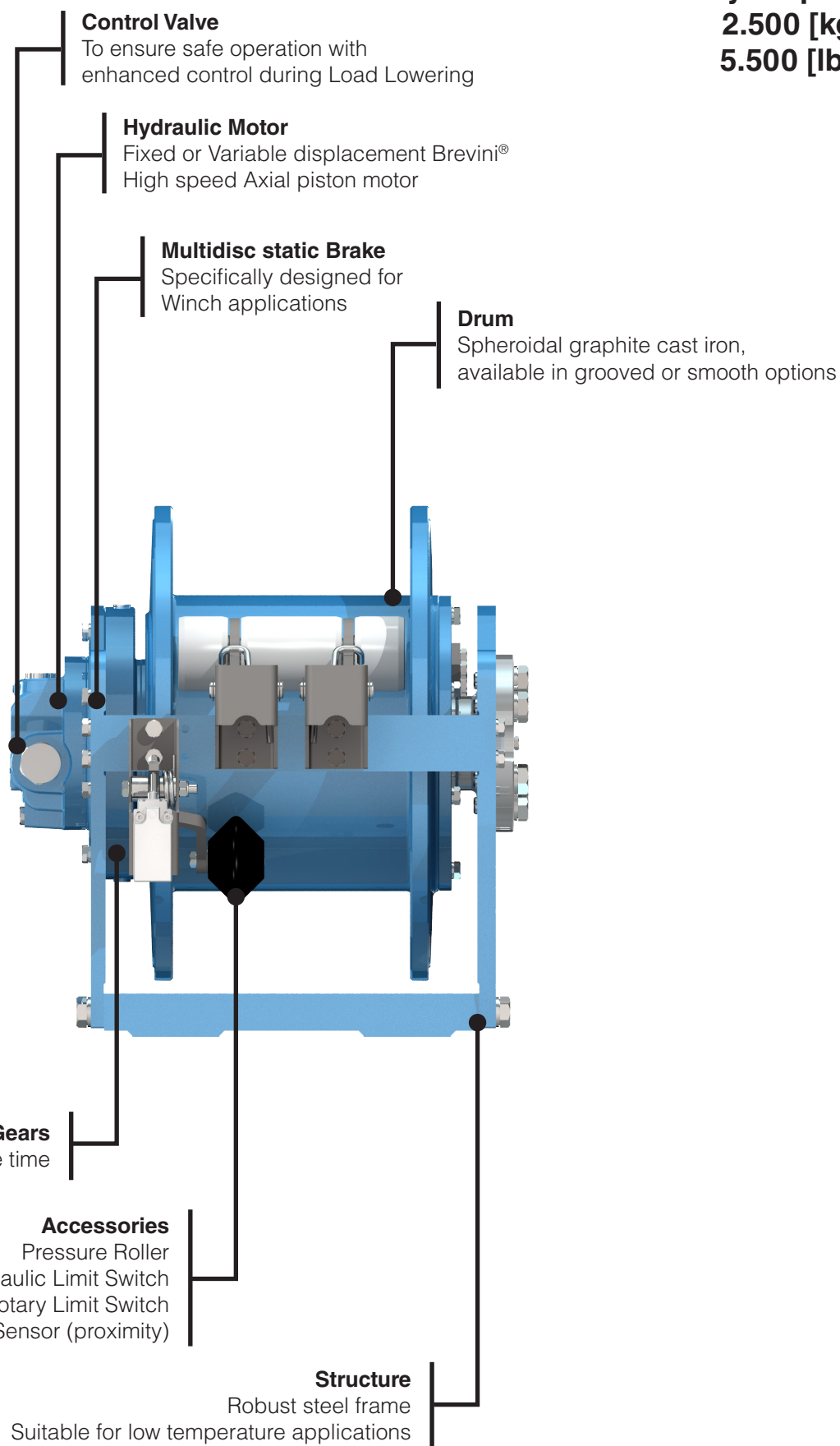

Brevini® Hydraulic Motor

	Motor type	Displacement	L
Fixed Displacement	B5VA021 <sup>(1)</sup>	21 cm <sup>3</sup> /rev [1.28 in <sup>3</sup> /rev]	64.0 mm [2.519 in]
Fixed Displacement	BRZV250 <sup>(1)</sup>	250 cm <sup>3</sup> /rev [15.24 in <sup>3</sup> /rev]	105 mm [4.133 in]
With NO Motor	Universal Input Flange 00	-	22.5 mm [0.886 in]

Winch - standard <sup>(3)</sup>

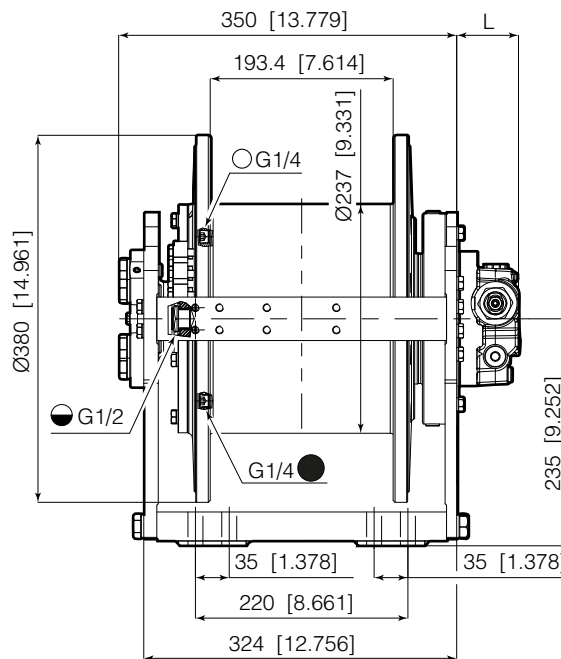
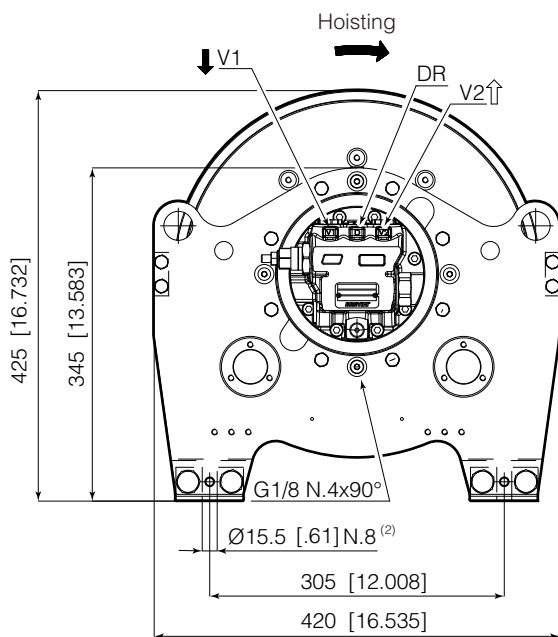

Winch - extended drum <sup>(3)</sup>

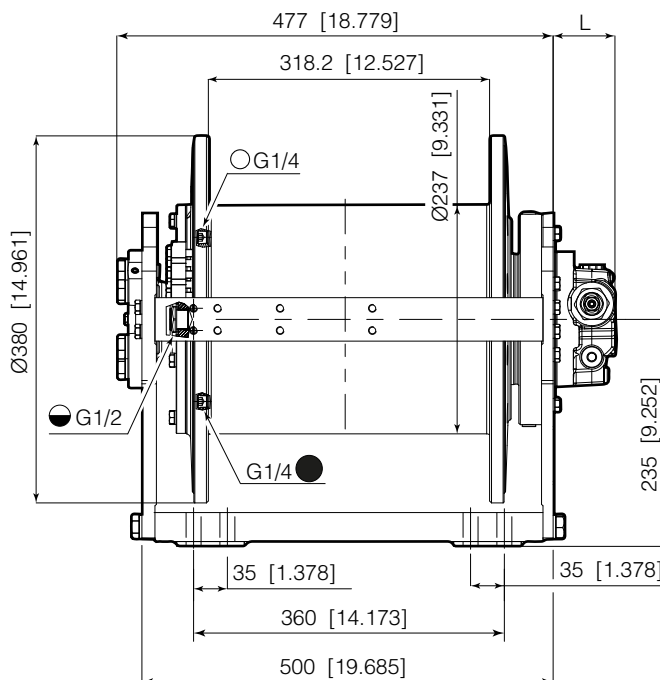
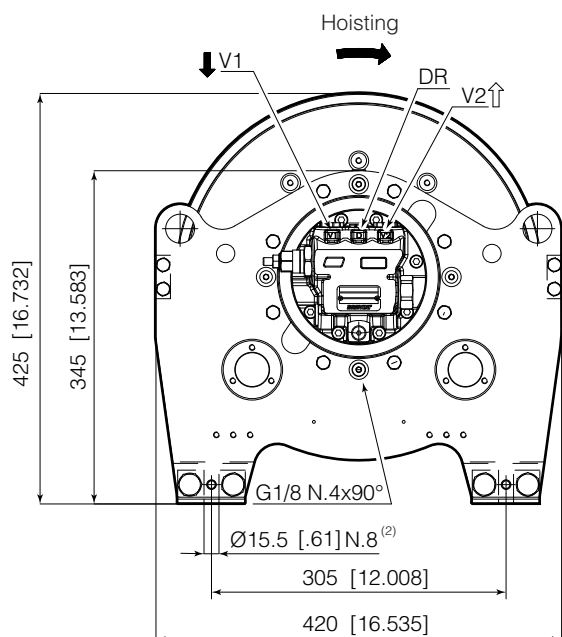

<sup>(1)</sup> As Standard with single overcenter valve, double overcenter valve available on request.

<sup>(2)</sup> N. 8 bolts for ABS certified version only. N. 4 bolts for other versions.

<sup>(3)</sup> Catalogue dimensions only for reference, see dimensional drawing for detailed information

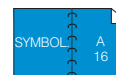

Brevini® Hydraulic Motor for Lifting of Personnel Winches

	Motor type	Displacement	L
Fixed Displacement	B5VA021 <sup>(1)</sup>	21 cm <sup>3</sup> /rev [1.28 in <sup>3</sup> /rev]	64.0 mm [2.519 in]
Fixed Displacement	BRZV250 <sup>(1)</sup>	250 cm <sup>3</sup> /rev [15.24 in <sup>3</sup> /rev]	105 mm [4.133 in]
With NO Motor	Universal Input Flange 00	-	22.5 mm [0.886 in]

Lifting of Personnel Winch - standard <sup>(4)</sup>

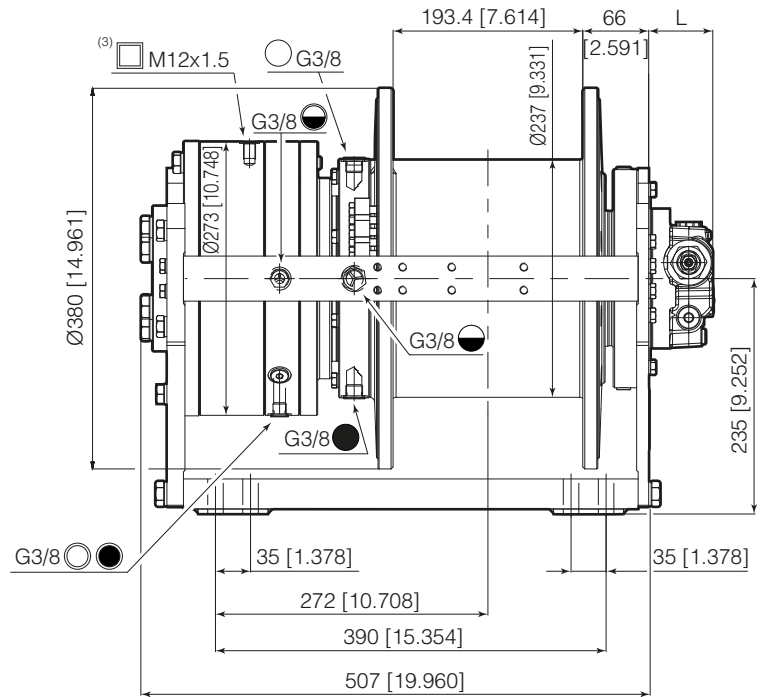
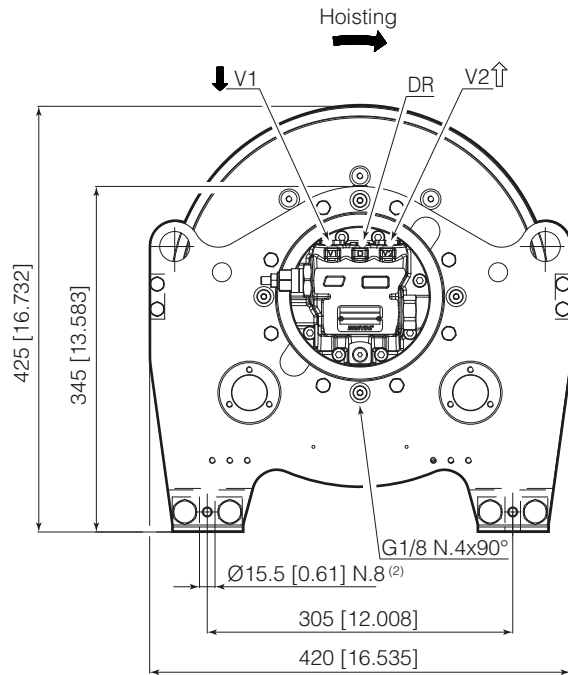

Lifting of Personnel Winch - extended drum <sup>(4)</sup>

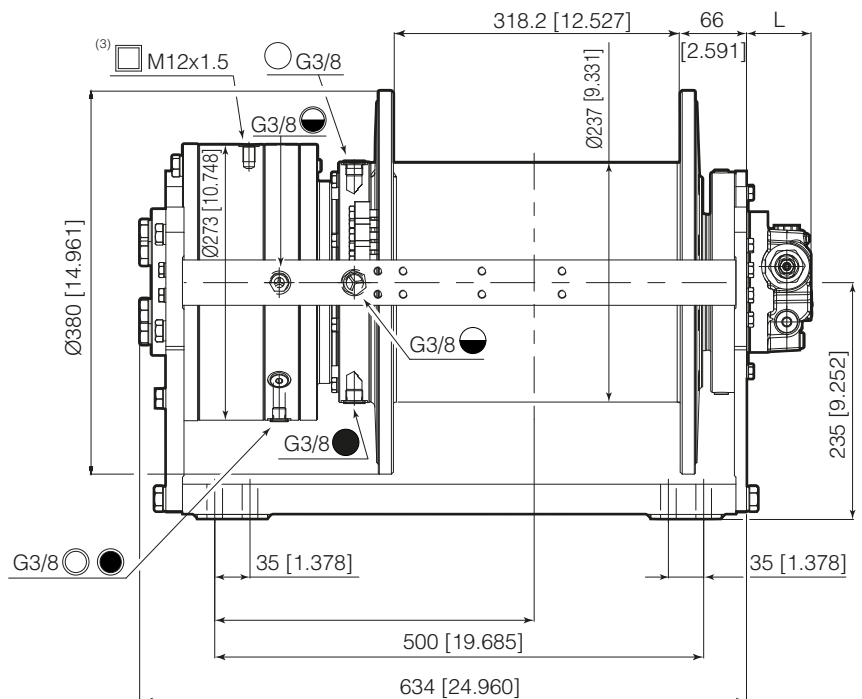
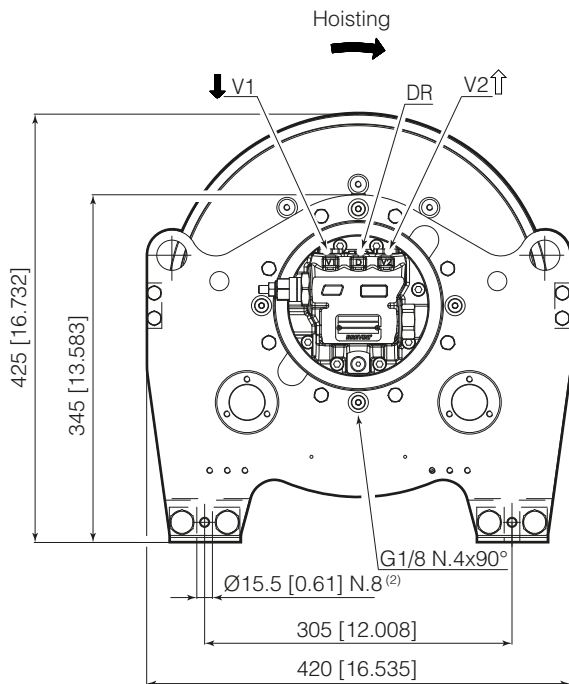

<sup>(1)</sup> As Standard with single overcenter valve, double overcenter valve available on request.

<sup>(2)</sup> N. 8 bolts for ABS certified version only. N. 4 bolts for other versions.

<sup>(3)</sup> Lifting of personnel brake release pressure (Release / Max) 27/315 bar [392/4570 psi]

<sup>(4)</sup> Catalogue dimensions only for reference, see dimensional drawing for detailed information

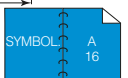

### Motor Drum Winch

Available on request .

- with or without motor
- smooth or grooved drum
- customized drum length
- different rope diameter

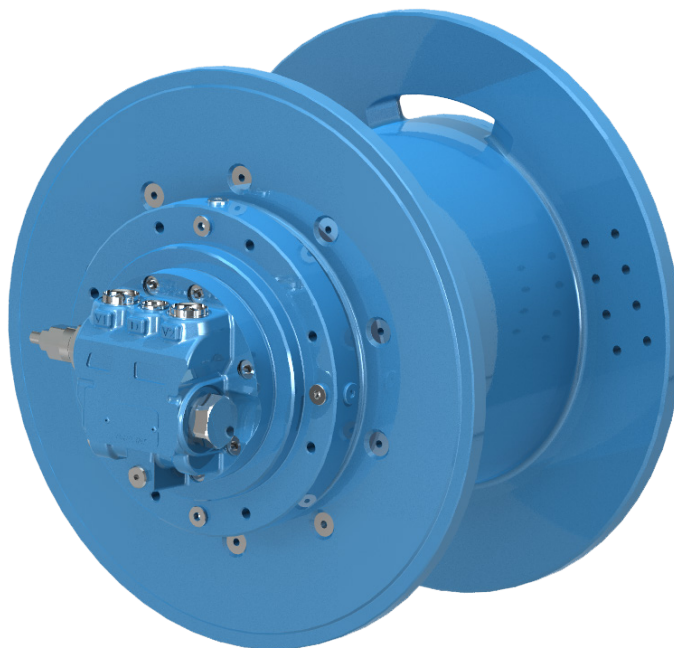

### Our Standard Configurations

<b>Hydraulic Motor Fixed Displacement</b>	<b>B5VA021</b>	21 [cm <sup>3</sup> /rev]	1.28 [in <sup>3</sup> /rev]
	<b>BRZV250</b>	250 [cm <sup>3</sup> /rev]	15.24 [in <sup>3</sup> /rev]
<b>Ratio</b>		37.4	
		5.53	
<b>Drum</b>	<b>standard</b>	Smooth Drum Special Grooved Drum <sup>(1)</sup>	
	<b>extended</b>	Smooth Drum Special Grooved Drum <sup>(1)</sup>	
<b>Rope</b>		Ø 10 [mm]	Ø 0.39 [in]
		Ø 12 [mm]	Ø 0.47 [in]
		Ø 14 [mm]	Ø 0.55 [in]

<sup>(1)</sup> Left hand grooving as Standard only with rope diameter Ø 12 mm [0.47 in]. Right hand grooving on request. Other rope diameter available on request.



## International System of Units: SI

BWE025-SD12..-01-37.4-APF021

Working layer		1	2	3	4	5	6
		<b>Storage length</b>					
Line pull	[kg]	2500	2310	2150	2000	1880	-
Rope speed	[m/min]	46	50	54	58	62	-
Rope length	[m]	12	24	38	52	68	84
Brevini® Motor	B5VA021	Advised rope diameter		12	[mm]		
Starting lifting pressure	335 [bar]	Oil fill / drain plug		G1/4	T		
Operating pressure	285 [bar]	Lifting / Lowering port		G1/2	V1 / V2		
Operating oil flow at the motor	50 [l/min]	Motor drain port		G1/4	DR		
Minimum oil flow at the motor	5.0 [l/min]	Static braking torque <sup>(1)</sup>		180	[Nm]		
Gear ratio	37.4 [i]	Brake release pressure (Release/Max)		34 / 350	[bar]		
Winch mechanisms classification in agreement with F.E.M. (1.001) (Third edition revised on 01.10.1998)						M5 (T5-L2)	n <sub>2</sub> =15 [rpm]

		Weight [kg]		Oil [l]	
		Cargo	LoP	Cargo	LoP
<b>BWE025/B5VA021</b>	Standard	122	177	1.4	2.2
	Extended drum	136	194	3.3	4.2

## United States Customary Units: USC

BWE025-SD12..-01-37.4-APF021

Working layer		1	2	3	4	5	6
		<b>Storage length</b>					
Line pull	[lbf]	5500	5100	4740	4420	4150	-
Rope speed	[fpm]	153	166	178	191	204	-
Rope length	[ft]	39	80	126	172	225	278
Brevini® Motor	B5VA021	Advised rope diameter		0.47	[in]		
Starting lifting pressure	4915 [psi]	Oil fill / drain plug		G1/4	T		
Operating pressure	4100 [psi]	Lifting / Lowering port		G1/2	V1 / V2		
Operating oil flow at the motor	13 [gpm]	Motor drain port		G1/4	DR		
Minimum oil flow at the motor	1.32 [gpm]	Static braking torque <sup>(1)</sup>		132	[ft·lbf]		
Gear ratio	37.4 [i]	Brake release pressure (Release/Max)		495 / 5080	[psi]		
Winch mechanisms classification in agreement with F.E.M. (1.001) (Third edition revised on 01.10.1998)						M5 (T5-L2)	n <sub>2</sub> =15 [rpm]

		Weight [lbs]		Oil [gal]	
		Cargo	LoP	Cargo	LoP
<b>BWE025/B5VA021</b>	Standard	269	390	0.37	0.58
	Extended drum	300	428	0.87	1.11

**Note:**

- For safety reasons always keep at least 3 wraps of rope wrapped on the drum.
- Technical features may change with no previous notice from the manufacturer.
- The MBL of the Rope must be verified according to the requested Safety Factors.
- All data shown in this page are ONLY FOR INFORMATION. The actual data will be issued according to Customer application and Duty Cycle.

<sup>(1)</sup> Static braking torque does not affect the winch maximum static line pull which must be considered 125% of the nominal line pull at first layer.

## Line pull for Certified Winch Version: SI

Rope Diameter	Line Pull (according to DNVGL) [kg]				Line Pull (according to ABS) [kg]			
	Cargo Winch		Lifting of Personnell Winch		Cargo Winch		Lifting of Personnell Winch	
	Last Layer	First Layer	Last Layer	First Layer	Last Layer	First Layer	Last Layer	First Layer
Ø 10 [mm]	1332 (5) <sup>(1)</sup>	1700	509 (5) <sup>(1)</sup>	650	1332 (5) <sup>(1)</sup>	1700	627 (5) <sup>(1)</sup>	800
Ø 12 [mm]	1844 (4) <sup>(1)</sup>	2300	521 (4) <sup>(1)</sup>	650	1764 (4) <sup>(1)</sup>	2200	642 (4) <sup>(1)</sup>	800
Ø 14 [mm]	1932 (3) <sup>(1)</sup>	2300	546 (3) <sup>(1)</sup>	650	1848 (3) <sup>(1)</sup>	2200	672 (3) <sup>(1)</sup>	800

## Line pull for Certified Winch Version: USC

Rope Diameter	Line Pull (according to DNVGL) [lbf]				Line Pull (according to ABS) [lbf]			
	Cargo Winch		Lifting of Personnell Winch		Cargo Winch		Lifting of Personnell Winch	
	Last Layer	First Layer	Last Layer	First Layer	Last Layer	First Layer	Last Layer	First Layer
Ø 0.39 [in]	2936 (5) <sup>(1)</sup>	3778	1122 (5) <sup>(1)</sup>	1445	2936 (5) <sup>(1)</sup>	3778	1382 (5) <sup>(1)</sup>	1778
Ø 0.47 [in]	4064 (4) <sup>(1)</sup>	5112	1148 (4) <sup>(1)</sup>	1445	3888 (4) <sup>(1)</sup>	4890	1415 (4) <sup>(1)</sup>	1778
Ø 0.55 [in]	4258 (3) <sup>(1)</sup>	5112	1203 (3) <sup>(1)</sup>	1445	4073 (3) <sup>(1)</sup>	4890	1482 (3) <sup>(1)</sup>	1778

The line pull listed above are just for reference, for this application is strongly recommended to fill up the Winch Application Data Form available at the end of this catalogue and consult the Dana area contact person for final selection and validation.

## Other Ropes available - standard

Working layer			1	2	3	4	5	6
Rope Diameter Ø 10 [mm]	Rope length	[m]	14	29	45	61	80	98
Rope Diameter Ø 14 [mm]	Rope length	[m]	10	21	33	46	60	-

Working layer			1	2	3	4	5	6
Rope Diameter Ø 0.39 [in]	Rope length	[ft]	47	95	149	203	263	323
Rope Diameter Ø 0.55 [in]	Rope length	[ft]	34	69	110	150	198	-

Last indicated Layer is intended only as Storage

## Other Ropes available - extended

Working layer			1	2	3	4	5	6
Rope Diameter Ø 10 [mm]	Rope length	[m]	23	48	75	103	133	164
Rope Diameter Ø 12 [mm]	Rope length	[m]	19	40	63	87	114	141
Rope Diameter Ø 14 [mm]	Rope length	[m]	17	35	55	76	100	-

Working layer			1	2	3	4	5	6
Rope Diameter Ø 0,39 [in]	Rope length	[ft]	77	158	247	338	437	538
Rope Diameter Ø 0,47 [in]	Rope length	[ft]	65	133	209	288	375	463
Rope Diameter Ø 0,55 [in]	Rope length	[ft]	56	115	182	252	330	-

Last indicated Layer is intended only as Storage

<sup>(1)</sup> Last working layer

Axial Piston Motor Fixed Displacement

Maximum Line pull at first layer

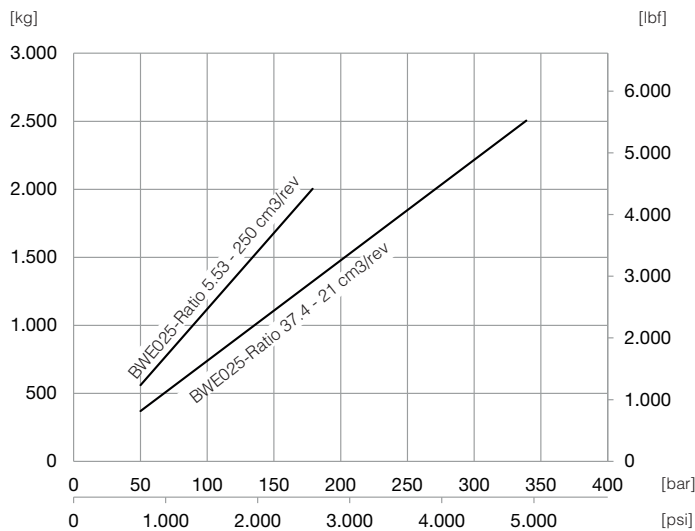

Maximum Speed at first layer

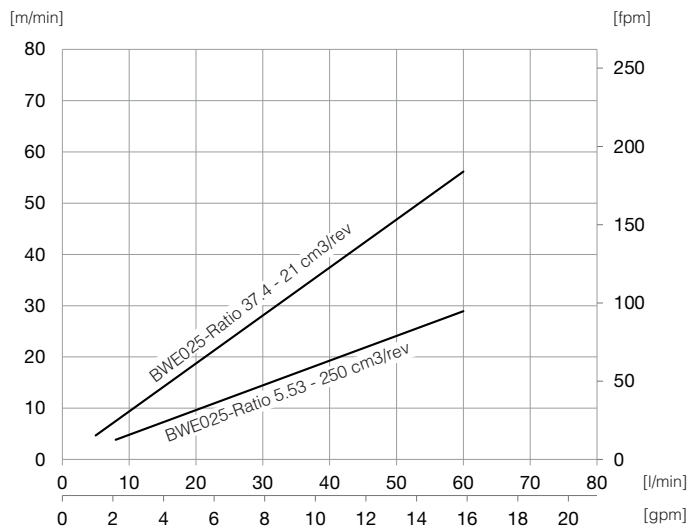

**Note:**

- All data shown in this page are ONLY FOR INFORMATION. The actual data will be issued according to Customer application and Duty Cycle.



**BREVINI<sup>®</sup>**

*Motion Systems*

**Line Pull at first Layer up to:**  
**3.500 [kg]**  
**7.700 [lbf]**

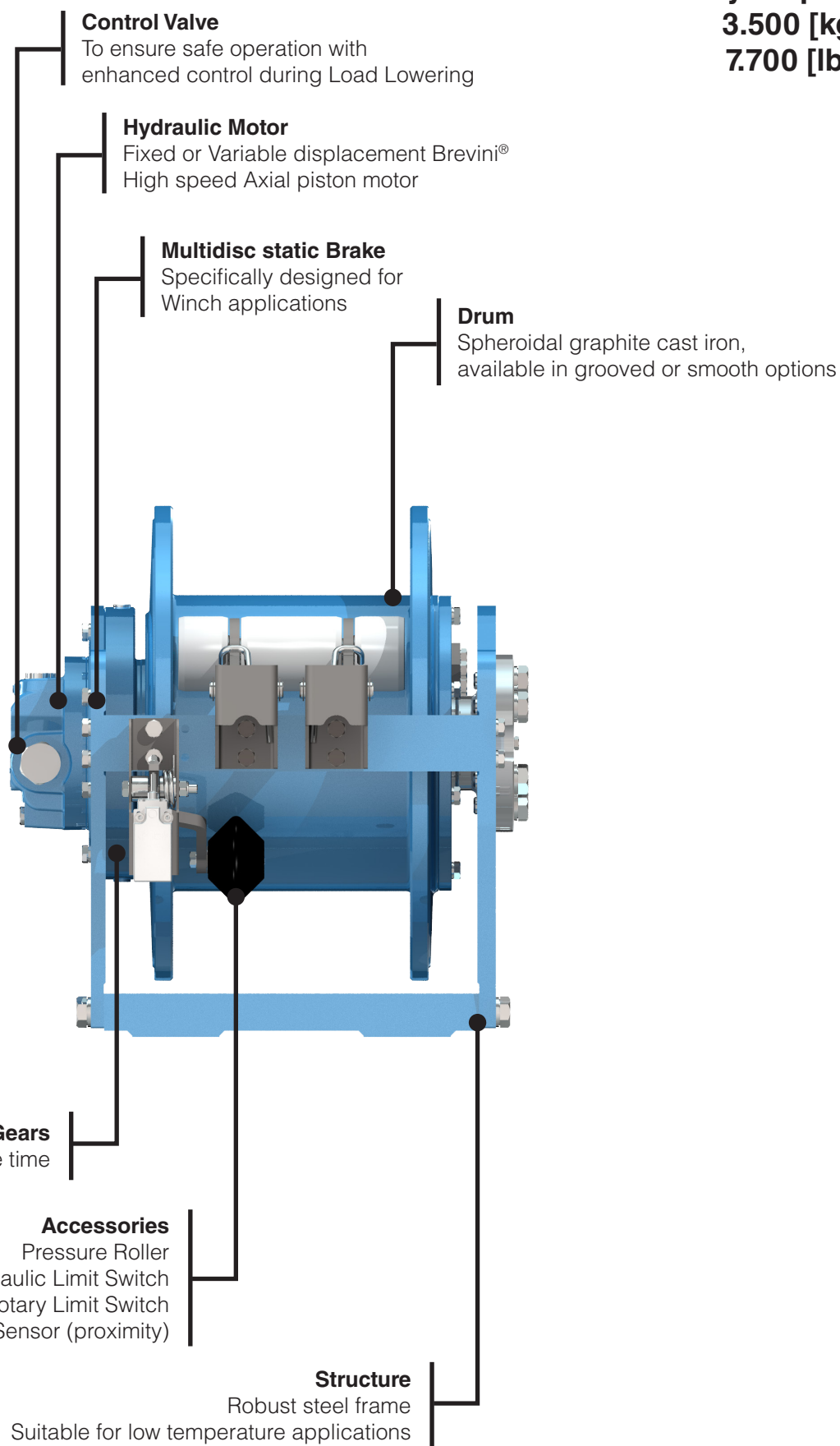

Brevini® Hydraulic Motor

	Motor type	Displacement	L
Fixed Displacement	B5VA037 <sup>(1)</sup>	37 cm <sup>3</sup> /rev [2.25 in <sup>3</sup> /rev]	71 mm [2.795 in]
Fixed Displacement	B5VA068 <sup>(1)</sup>	68 cm <sup>3</sup> /rev [4.14 in <sup>3</sup> /rev]	98 mm [3.858 in]
Fixed Displacement	BRZV100 <sup>(1)</sup>	100 cm <sup>3</sup> /rev [6.1 in <sup>3</sup> /rev]	60.5 mm [23.819 in]
With NO Motor	Universal Input Flange 00	-	0 mm

Winch - standard <sup>(2)</sup>

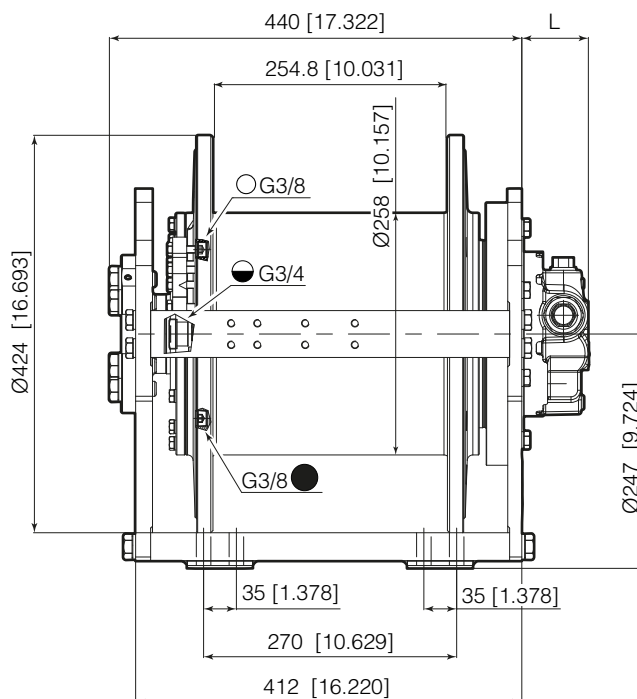
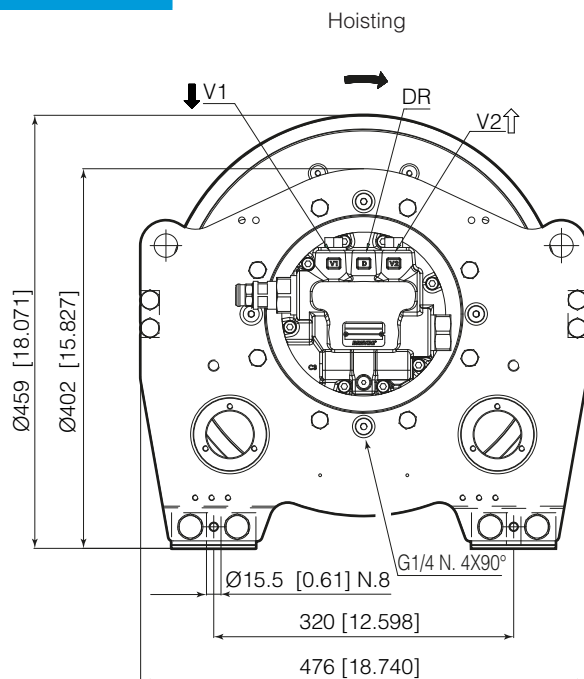

Winch - extended drum <sup>(2)</sup>

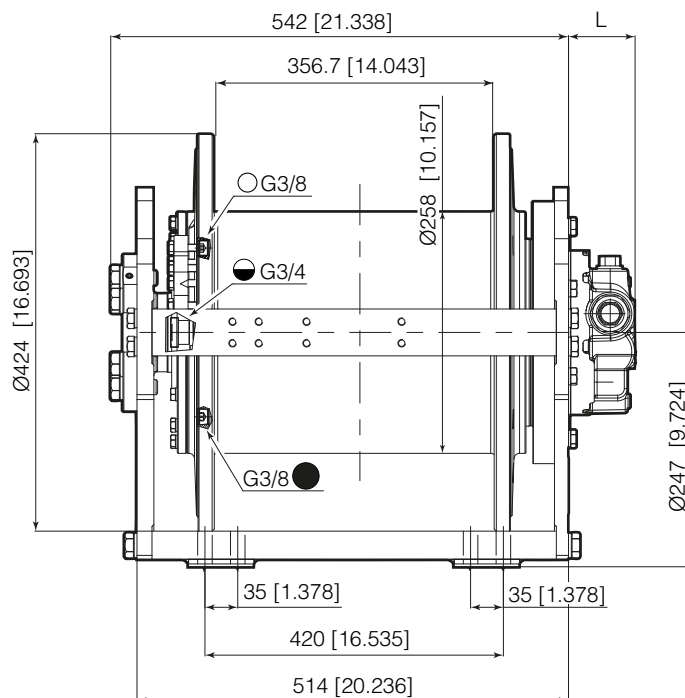
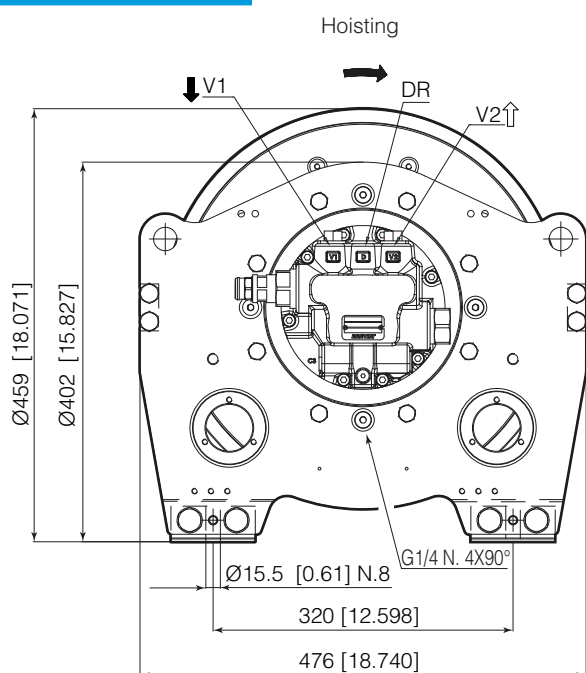

<sup>(1)</sup> As Standard with single overcenter valve, double overcenter valve available on request.

<sup>(2)</sup> Catalogue dimensions only for reference, see dimensional drawing for detailed information.

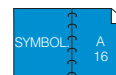

Brevini® Hydraulic Motor for Lifting of Personnel Winches

	Motor type	Displacement	L
Fixed Displacement	B5VA037 <sup>(1)</sup>	37 cm <sup>3</sup> /rev [2.25 in <sup>3</sup> /rev]	71 mm [2.795 in]
Fixed Displacement	B5VA068 <sup>(1)</sup>	68 cm <sup>3</sup> /rev [4.14 in <sup>3</sup> /rev]	98 mm [3.858 in]
Fixed Displacement	BRZV100 <sup>(1)</sup>	100 cm <sup>3</sup> /rev [6.1 in <sup>3</sup> /rev]	60.5 mm [23.819 in]
With NO Motor	Universal Input Flange 00	-	0 mm

Lifting of Personnel Winch - standard <sup>(3)</sup>

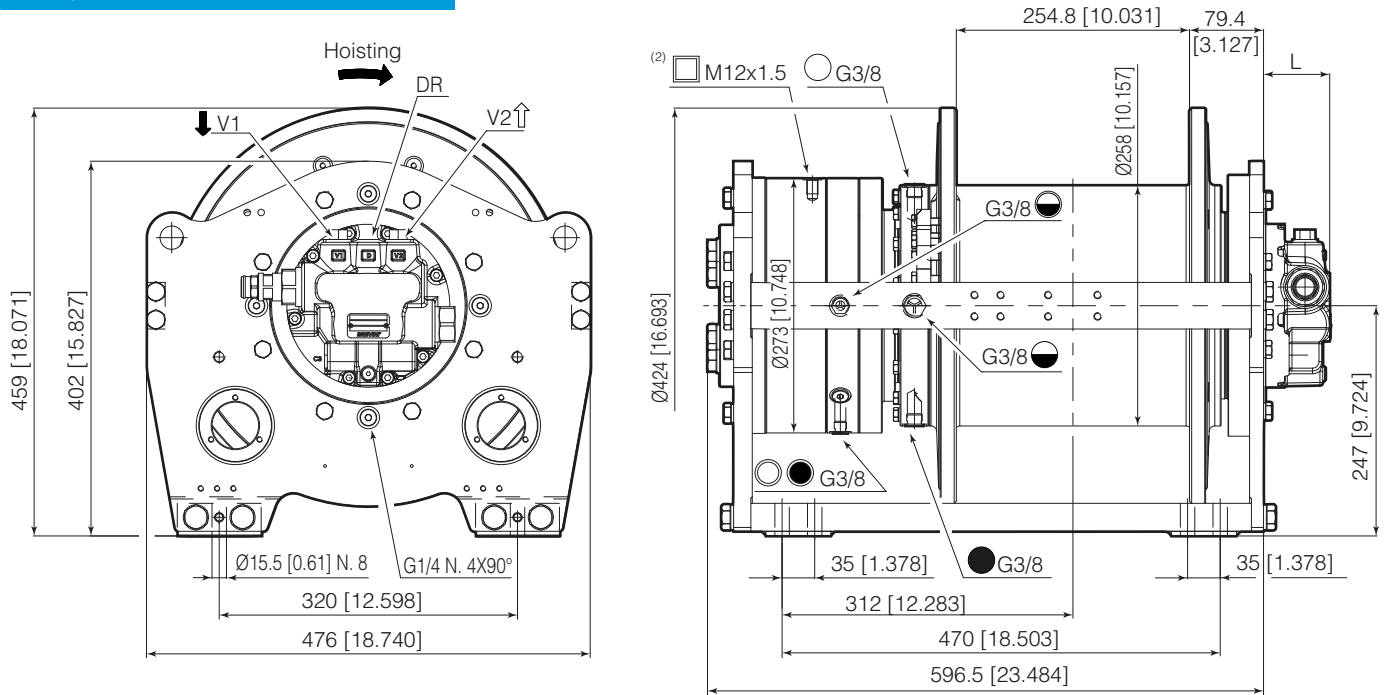

Lifting of Personnel Winch - extended drum <sup>(3)</sup>

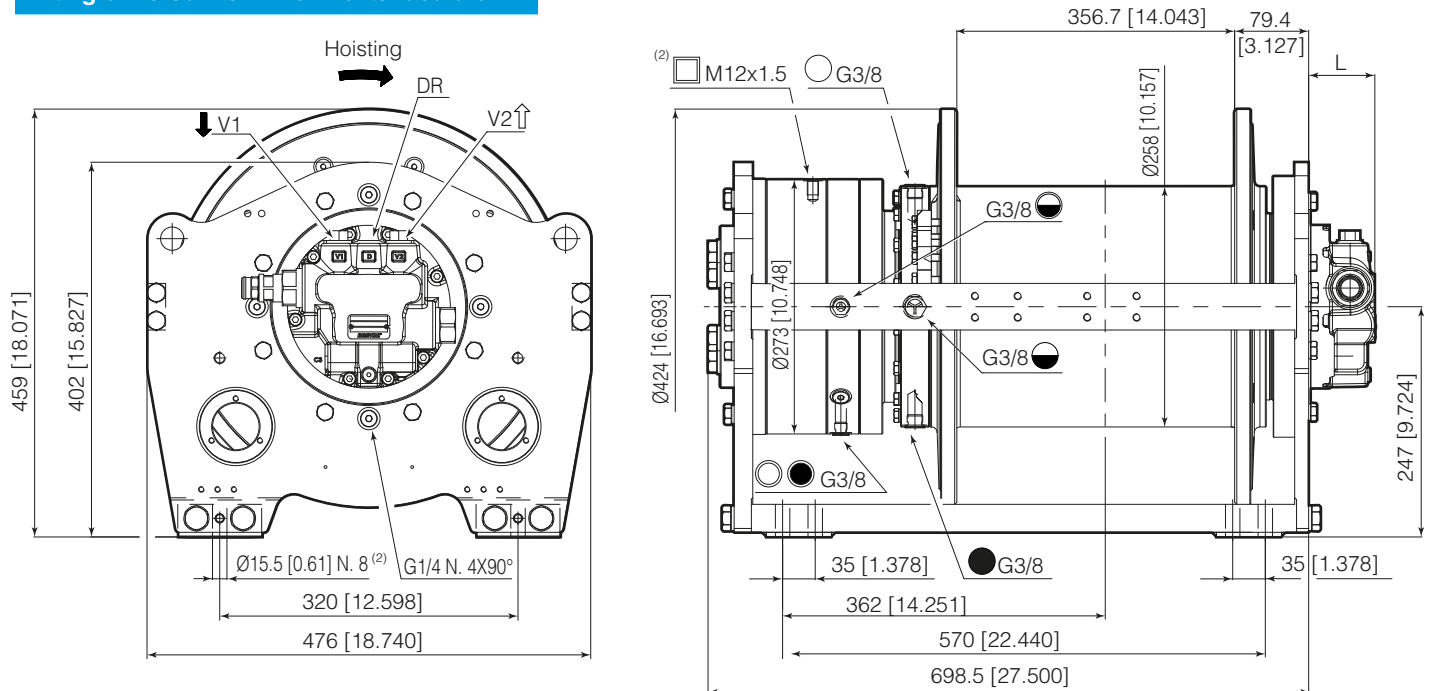

<sup>(1)</sup> As Standard with single overcenter valve, double overcenter valve available on request.

<sup>(2)</sup> Lifting of personnel brake release pressure (Release / Max) 27/315 bar [392/4570 psi]

<sup>(3)</sup> Catalogue dimensions only for reference, see dimensional drawing for detailed information

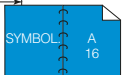

### Motor Drum Winch

Available on request .

- with or without motor
- smooth or grooved drum
- customized drum length
- different rope diameter

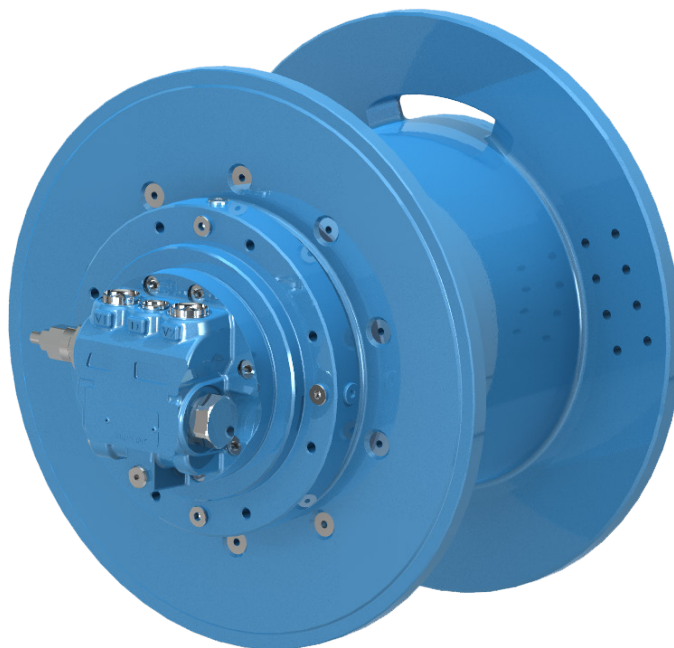

### Our Standard Configurations

Hydraulic Motor Fixed Displacement	<b>B5VA037</b>	37 [cm <sup>3</sup> /rev]	2.25 [in <sup>3</sup> /rev]
	<b>B5VA068</b>	68 [cm <sup>3</sup> /rev]	4.14 [in <sup>3</sup> /rev]
	<b>BRZV100</b>	100 [cm <sup>3</sup> /rev]	6.1 [in <sup>3</sup> /rev]
Ratio		33.6	
		22.9	
Drum	<b>standard</b>	Smooth Drum Special Grooved Drum <sup>(1)</sup>	
	<b>extended</b>	Smooth Drum Special Grooved Drum <sup>(1)</sup>	
Rope		Ø 12 [mm]	Ø 0.47 [in]
		Ø 14 [mm]	Ø 0.55 [in]
		Ø 16 [mm]	Ø 0.63 [in]

<sup>(1)</sup> Left hand grooving as Standard only with rope diameter Ø 14 mm [0.55 in]. Right handal grooving on request. Other rope diameter available on request.



International System of Units: SI

BWE035-SD14..-01-33.6-APF037

Working layer		1	2	3	4	5	6
		<b>Storage length</b>					
Line pull	[kg]	3500	3220	2980	2770	2590	-
Rope speed	[m/min]	32	35	37	40	43	-
Rope length	[m]	14	30	47	65	85	106
Brevini® Motor	B5VA037	Advised rope diameter		14	[mm]		
Starting lifting pressure	325 [bar]	Oil fill / drain plug		G3/4	T		
Operating pressure	275 [bar]	Lifting / Lowering port		G1/2	V1 / V2		
Operating oil flow at the motor	50 [l/min]	Motor drain port		G3/8	DR		
Minimum oil flow at the motor	5.0 [l/min]	Static braking torque <sup>(1)</sup>		352	[Nm]		
Gear ratio	33.6 [i]	Brake release pressure (Release/Max)		34 / 350	[bar]		
Winch mechanisms classification in agreement with F.E.M. (1.001) (Third edition revised on 01.10.1998)						M5 (T5-L2)	n <sub>2</sub> =15 [rpm]

		Weight [kg]		Oil [l]	
		Cargo	LoP	Cargo	LoP
<b>BWE035/B5VA037</b>	Standard	187	250	2.7	3.8
	Extended drum	203	266	4.5	5.3

United States Customary Units: USC

BWE035-SD14..-01-33.6-APF037

Working layer		1	2	3	4	5	6
		<b>Storage length</b>					
Line pull	[lbf]	7700	7100	6570	6110	5710	-
Rope speed	[fpm]	105	115	124	133	143	-
Rope length	[ft]	49	99	157	215	281	348
Brevini® Motor	B5VA037	Advised rope diameter		0.55	[in]		
Starting lifting pressure	4740 [psi]	Oil fill / drain plug		G3/4	[gal]		
Operating pressure	3955 [psi]	Lifting / Lowering port		G1/2	V1 / V2		
Operating oil flow at the motor	13 [gpm]	Motor drain port		G3/8	DR		
Minimum oil flow at the motor	1.32 [gpm]	Static braking torque <sup>(1)</sup>		259	[ft·lbf]		
Gear ratio	33.6 [i]	Brake release pressure (Release/Max)		495 / 5080	[psi]		
Winch mechanisms classification in agreement with F.E.M. (1.001) (Third edition revised on 01.10.1998)						M5 (T5-L2)	n <sub>2</sub> =15 [rpm]

		Weight [lbs]		Oil [gal]	
		Cargo	LoP	Cargo	LoP
<b>BWE035/B5VA037</b>	Standard	412	551	0.71	1.00
	Extended drum	448	586	1.19	1.40

**Note:**

- For safety reasons always keep at least 3 wraps of rope wrapped on the drum.
- Technical features may change with no previous notice from the manufacturer.
- The MBL of the Rope must be verified according to the requested Safety Factors.
- All data shown in this page are ONLY FOR INFORMATION. The actual data will be issued according to Customer application and Duty Cycle.

<sup>(1)</sup> Static braking torque does not affect the winch maximum static line pull which must be considered 125% of the nominal line pull at first layer.

## Line pull for Certified Winch Version: SI

Rope Diameter	Line Pull (according to DNVGL) [kg]				Line Pull (according to ABS) [kg]			
	Cargo Winch		Lifting of Personnell Winch		Cargo Winch		Lifting of Personnell Winch	
	Last Layer	First Layer	Last Layer	First Layer	Last Layer	First Layer	Last Layer	First Layer
Ø 12 [mm]	1918 (5) <sup>(1)</sup>	2500	690 (5) <sup>(1)</sup>	900	1918 (5) <sup>(1)</sup>	2500	805 (5) <sup>(1)</sup>	1050
Ø 14 [mm]	2690 (4) <sup>(1)</sup>	3400	712 (4) <sup>(1)</sup>	900	2532 (4) <sup>(1)</sup>	3200	831 (4) <sup>(1)</sup>	1050
Ø 16 [mm]	2834 (3) <sup>(1)</sup>	3400	750 (3) <sup>(1)</sup>	900	2668 (3) <sup>(1)</sup>	3200	875 (3) <sup>(1)</sup>	1050

## Line pull for Certified Winch Version: USC

Rope Diameter	Line Pull (according to DNVGL) [lbf]				Line Pull (according to ABS) [lbf]			
	Cargo Winch		Lifting of Personnell Winch		Cargo Winch		Lifting of Personnell Winch	
	Last Layer	First Layer	Last Layer	First Layer	Last Layer	First Layer	Last Layer	First Layer
Ø 0.47 [in]	4262 (5) <sup>(1)</sup>	5556	1533 (5) <sup>(1)</sup>	2000	4262 (5) <sup>(1)</sup>	5556	1789 (5) <sup>(1)</sup>	2333
Ø 0.55 [in]	5978 (4) <sup>(1)</sup>	7556	1582 (4) <sup>(1)</sup>	2000	5627 (4) <sup>(1)</sup>	7111	1847 (4) <sup>(1)</sup>	2333
Ø 0.63 [in]	6298 (3) <sup>(1)</sup>	7556	1667 (3) <sup>(1)</sup>	2000	5929 (3) <sup>(1)</sup>	7111	1944 (3) <sup>(1)</sup>	2333

The line pull listed above are just for reference, for this application is strongly recommended to fill up the Winch Application Data Form available at the end of this catalogue and consult the Dana area contact person for final selection and validation.

## Other Ropes available - standard

Working layer			1	2	3	4	5	6
Rope Diameter Ø 12 [mm]	Rope length	[m]	17	35	54	75	97	120
Rope Diameter Ø 16 [mm]	Rope length	[m]	13	26	42	58	76	-

Working layer			1	2	3	4	5	6
Rope Diameter Ø 0.47 [in]	Rope length	[ft]	56	114	180	246	320	395
Rope Diameter Ø 0.63 [in]	Rope length	[ft]	43	87	139	192	252	-

Last indicated Layer is intended only as Storage

## Other Ropes available - extended

Working layer			1	2	3	4	5	6
Rope Diameter Ø 12 [mm]	Rope length	[m]	24	49	77	106	137	169
Rope Diameter Ø 14 [mm]	Rope length	[m]	20	42	67	92	121	149
Rope Diameter Ø 16 [mm]	Rope length	[m]	18	37	59	82	108	-

Working layer			1	2	3	4	5	6
Rope Diameter Ø 0,47 [in]	Rope length	[ft]	79	162	253	347	451	557
Rope Diameter Ø 0,55 [in]	Rope length	[ft]	68	140	221	304	397	492
Rope Diameter Ø 0,63 [in]	Rope length	[ft]	60	124	196	271	356	-

Last indicated Layer is intended only as Storage

<sup>(1)</sup> Last working layer

Axial Piston Motor Fixed Displacement

Maximum Line pull at first layer

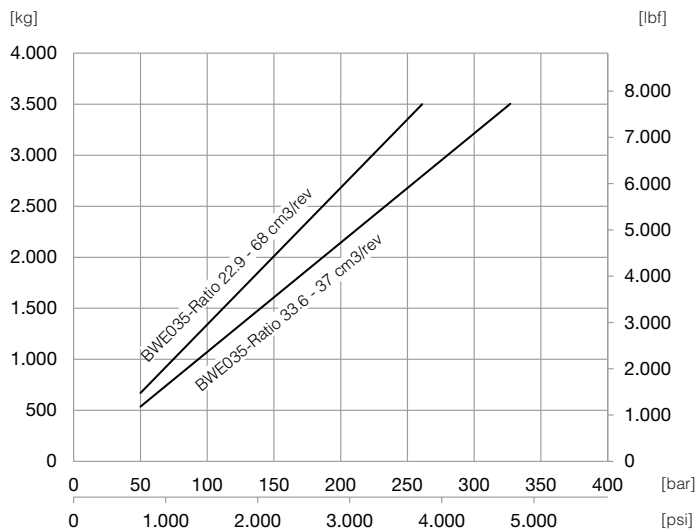

Maximum Speed at first layer

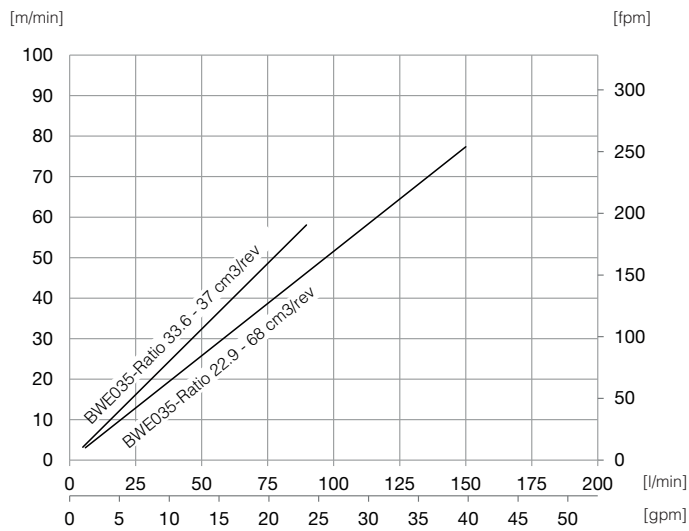

**Note:**

- All data shown in this page are ONLY FOR INFORMATION. The actual data will be issued according to Customer application and Duty Cycle.



**BREVINI<sup>®</sup>**

*Motion Systems*

**Line Pull at first Layer up to:**  
**5.500 [kg]**  
**12.100 [lbf]**

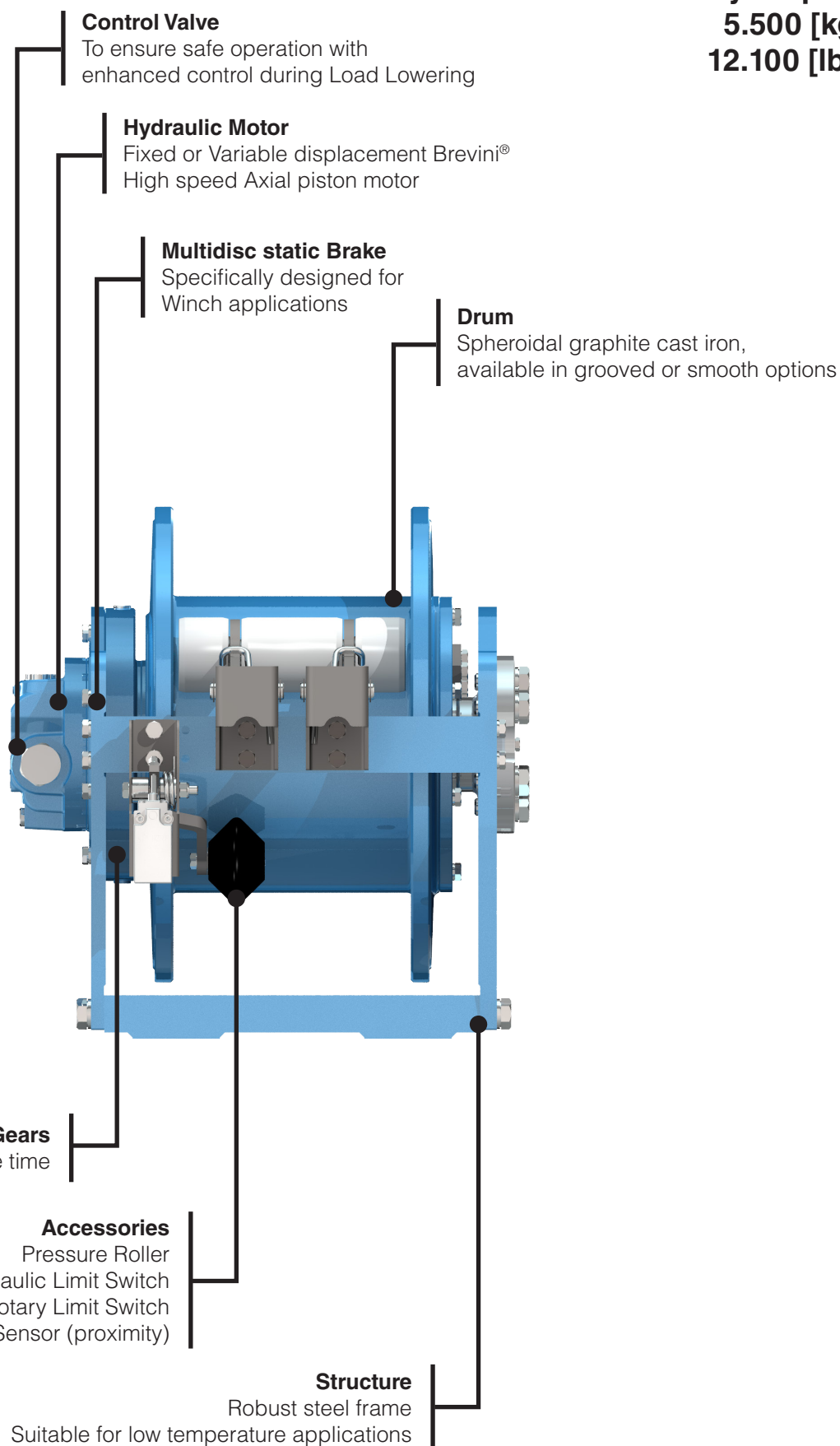

Brevini® Hydraulic Motor

	Motor type	Displacement	L
Fixed Displacement	B5VA068 <sup>(1)</sup>	68 cm <sup>3</sup> /rev [4.14 in <sup>3</sup> /rev]	78.5 mm [3.858 in]
Fixed Displacement	HR160 <sup>(1)</sup>	160 cm <sup>3</sup> /rev [9.72 in <sup>3</sup> /rev]	242.6 mm [9.551 in]
Fixed Displacement	SH11CR090 <sup>(1)</sup>	90 cm <sup>3</sup> /rev [5.47 in <sup>3</sup> /rev]	239 mm [9.409 in]
Variable Displacement	SH9V085 <sup>(1)</sup>	85 cm <sup>3</sup> /rev [5.17 in <sup>3</sup> /rev]	352 mm [13.858 in]
With NO Motor	Universal Input Flange 00	-	5.5 mm [0.216 in]

Winch - standard <sup>(3)</sup>

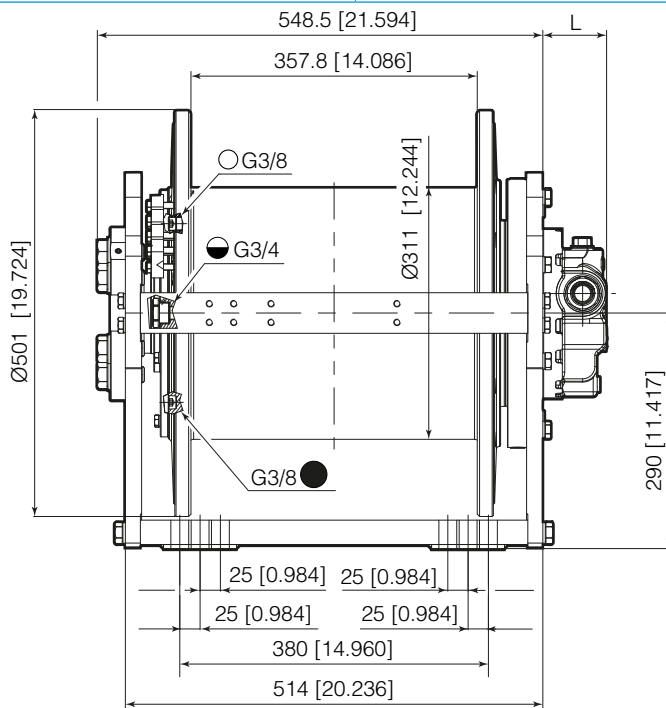
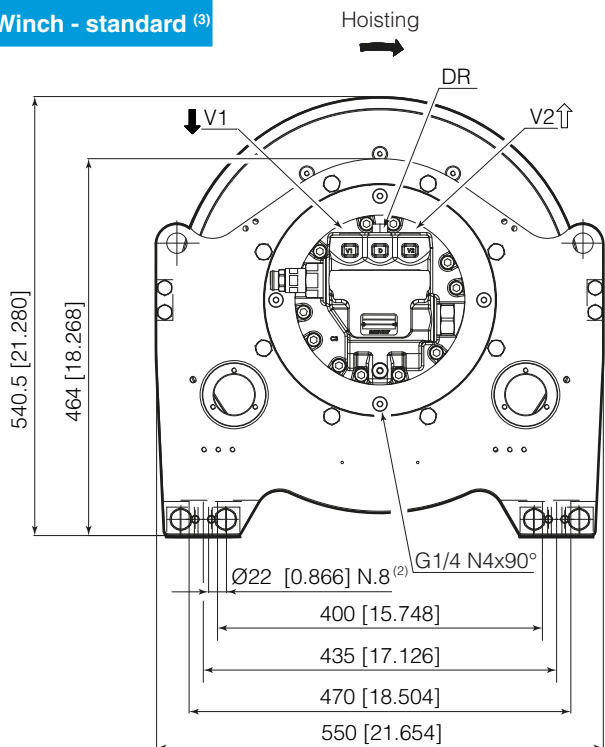

Winch - extended drum <sup>(3)</sup>

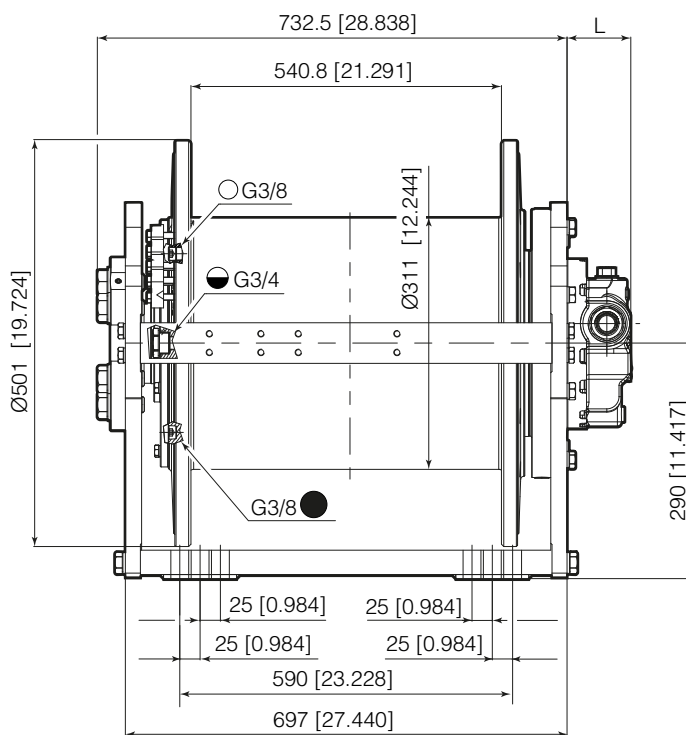
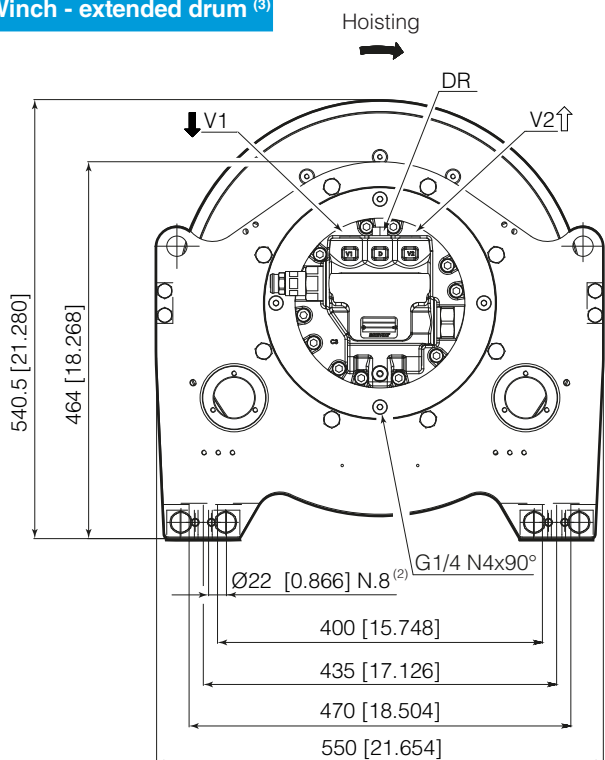

<sup>(1)</sup> As Standard with single overcenter valve, double overcenter valve available on request.

<sup>(2)</sup> N. 8 bolts for ABS certified version only. N. 4 bolts for other versions.

<sup>(3)</sup> Catalogue dimensions only for reference, see dimensional drawing for detailed information

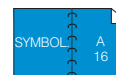

Brevini® Hydraulic Motor for Lifting of Personnel Winches

	Motor type	Displacement	L
Fixed Displacement	B5VA068 <sup>(1)</sup>	68 cm <sup>3</sup> /rev [4.14 in <sup>3</sup> /rev]	78.5 mm [3.858 in]
Fixed Displacement	HR160 <sup>(1)</sup>	160 cm <sup>3</sup> /rev [9.72 in <sup>3</sup> /rev]	242.6 mm [9.551 in]
Fixed Displacement	SH11CR090 <sup>(1)</sup>	90 cm <sup>3</sup> /rev [5.47 in <sup>3</sup> /rev]	239 mm [9.409 in]
Variable Displacement	SH9V085 <sup>(1)</sup>	85 cm <sup>3</sup> /rev [5.17 in <sup>3</sup> /rev]	352 mm [13.858 in]
With NO Motor	Universal Input Flange 00	-	5.5 mm [0.216 in]

Lifting of Personnel Winch - standard <sup>(4)</sup>

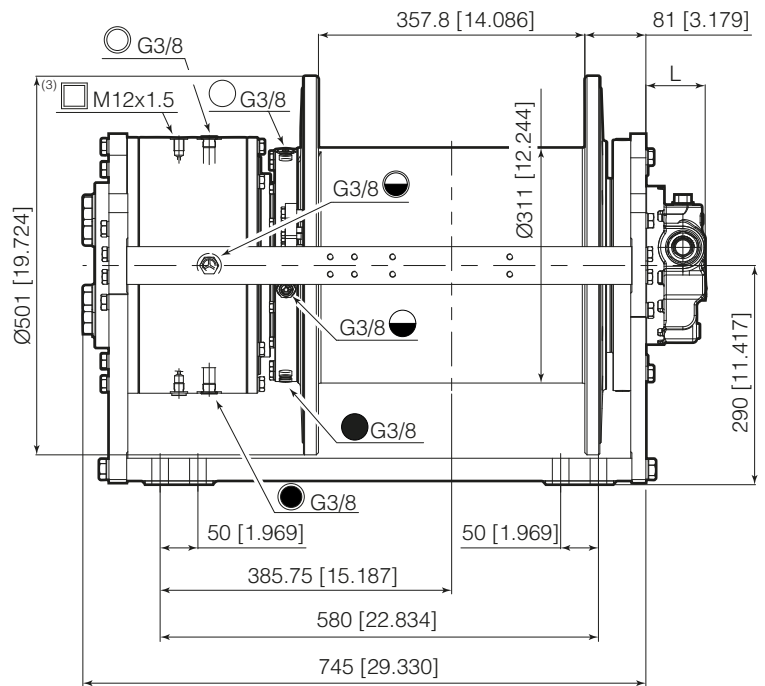
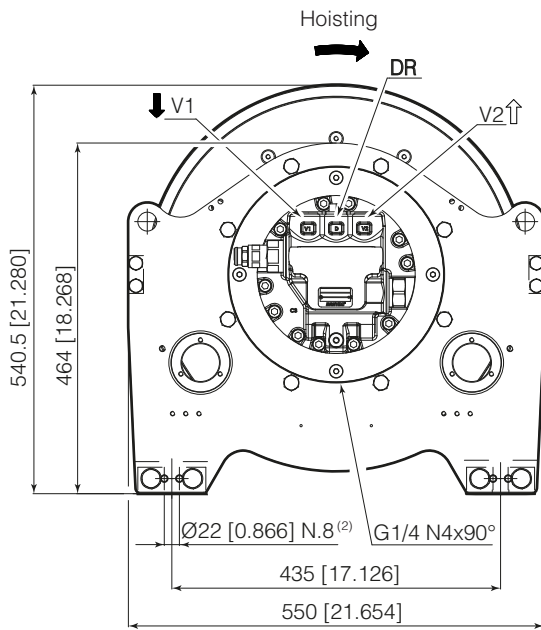

Lifting of Personnel Winch - extended drum <sup>(4)</sup>

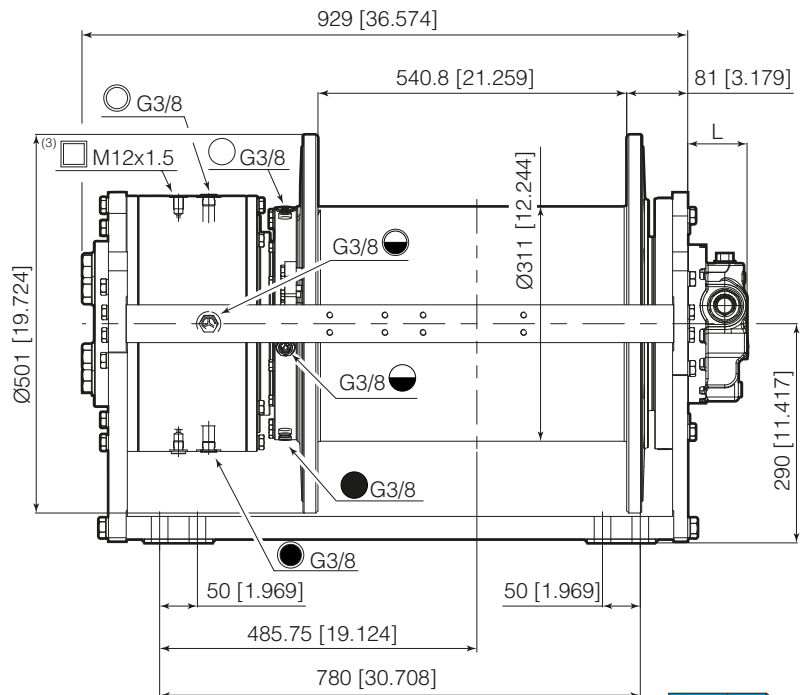
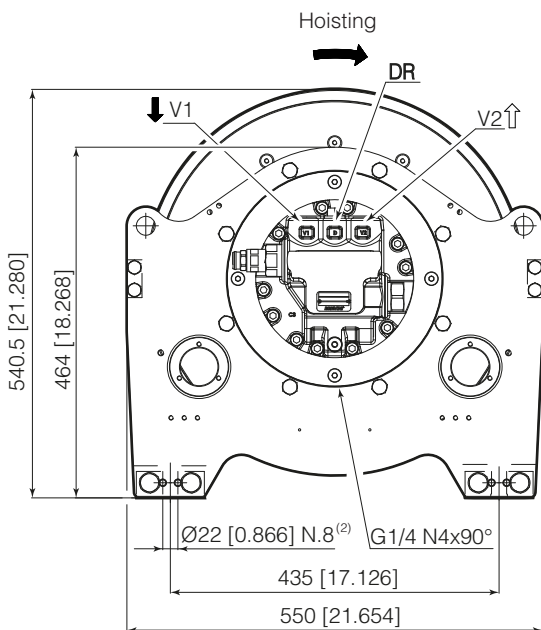

<sup>(1)</sup> As Standard with single overcenter valve, double overcenter valve available on request.

<sup>(2)</sup> N. 8 bolts for ABS certified version only. N. 4 bolts for other versions.

<sup>(3)</sup> Lifting of personnel brake release pressure (Release / Max) 27/315 bar [392/4570 psi]

<sup>(4)</sup> Catalogue dimensions only for reference, see dimensional drawing for detailed information

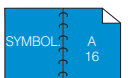

## Motor Drum Winch

Available on request .

- with or without motor
- smooth or grooved drum
- customized drum length
- different rope diameter

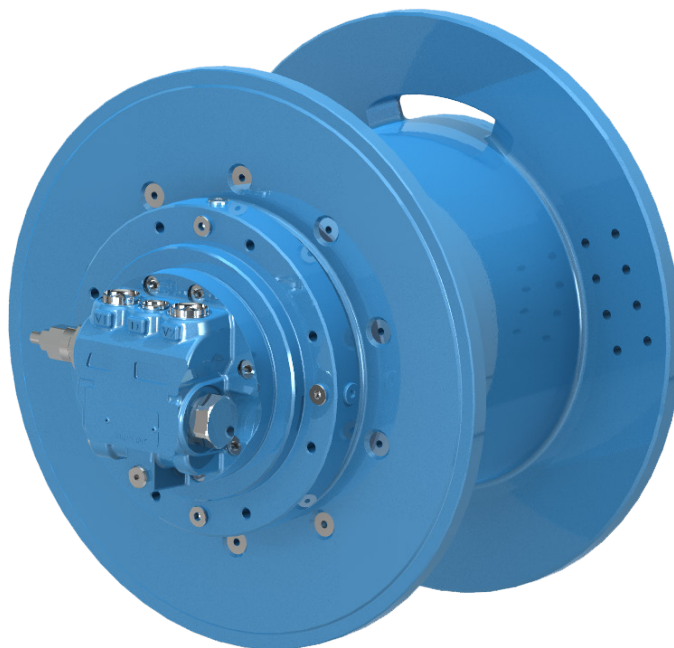

## Our Standard Configurations

Hydraulic Motor Fixed Displacement	<b>B5VA068</b>	68 [cm <sup>3</sup> /rev]	4.14 [in <sup>3</sup> /rev]
	<b>HR160</b>	160 [cm <sup>3</sup> /rev]	9.74 [in <sup>3</sup> /rev]
	<b>SH11CR090</b>	90 [cm <sup>3</sup> /rev]	5.47 [in <sup>3</sup> /rev]
Hydraulic Motor Variable Displacement	<b>SH9V085</b>	85 [cm <sup>3</sup> /rev]	5.17 [in <sup>3</sup> /rev]
Ratio		33.6	
		22.9	
Drum	<b>standard</b>	Smooth Drum Special Grooved Drum <sup>(1)</sup>	
	<b>extended</b>	Smooth Drum Special Grooved Drum <sup>(1)</sup>	
Rope		Ø 14 [mm]	Ø 0.55 [in]
		Ø 16 [mm]	Ø 0.63 [in]
		Ø 18 [mm]	Ø 0.71 [in]

<sup>(1)</sup> Left hand grooving as Standard only with rope diameter Ø 16 mm [0.63 in]. Right hand grooving on request. Other rope diameter available on request.



International System of Units: SI

BWE055-SD16..-01-22.9-APF090

Working layer		1	2	3	4	5	6
		<b>Storage length</b>					
Line pull	[kg]	5500	5070	4710	4390	4120	-
Rope speed	[m/min]	73	79	85	91	97	-
Rope length	[m]	22	44	70	97	126	156
Brevini® Motor	SH11CR090	Advised rope diameter		16		[mm]	
Starting lifting pressure	385 [bar]	Oil fill / drain plug		G3/8		T	
Operating pressure	325 [bar]	Lifting / Lowering port		G1		V1 / V2	
Operating oil flow at the motor	150 [l/min]	Motor drain port		G1/2		DR	
Minimum oil flow at the motor	6.0 [l/min]	Static braking torque <sup>(1)</sup>		778		[Nm]	
Gear ratio	22.9 [i]	Brake release pressure (Release/Max)		31 / 350		[bar]	
Winch mechanisms classification in agreement with F.E.M. (1.001) (Third edition revised on 01.10.1998)						M5 (T5-L2)	n <sub>2</sub> =15 [rpm]

		Weight [kg]		Oil [l]	
		Cargo	LoP	Cargo	LoP
<b>BWE055/B5VA068</b>	Standard	310	436	4.9	6.1
	Extended drum	362	480	9	10.2

United States Customary Units: USC

BWE055-SD16..-01-22.9-APF090

Working layer		1	2	3	4	5	6
		<b>Storage length</b>					
Line pull	[lbf]	12100	11190	10390	9690	9090	-
Rope speed	[fpm]	240	260	280	300	321	-
Rope length	[ft]	72	147	231	318	415	513
Brevini® Motor	SH11CR090	Advised rope diameter		0.62		[in]	
Starting lifting pressure	5640 [psi]	Oil fill / drain plug		G3/8		T	
Operating pressure	4705 [psi]	Lifting / Lowering port		G1		V1 / V2	
Operating oil flow at the motor	40 [gpm]	Motor drain port		G1/2		DR	
Minimum oil flow at the motor	1,58 [gpm]	Static braking torque <sup>(1)</sup>		573		[ft·lbf]	
Gear ratio	22.9 [i]	Brake release pressure (Release/Max)		450 / 5080		[psi]	
Winch mechanisms classification in agreement with F.E.M. (1.001) (Third edition revised on 01.10.1998)						M5 (T5-L2)	n <sub>2</sub> =15 [rpm]

		Weight [lbs]		Oil [gal]	
		Cargo	LoP	Cargo	LoP
<b>BWE055/B5VA068</b>	Standard	683	961	1.29	1.61
	Extended drum	798	1058	2.38	2.69

**Note:**

- For safety reasons always keep at least 3 wraps of rope wrapped on the drum.
- Technical features may change with no previous notice from the manufacturer.
- The MBL of the Rope must be verified according to the requested Safety Factors.
- All data shown in this page are ONLY FOR INFORMATION. The actual data will be issued according to Customer application and Duty Cycle.

<sup>(1)</sup> Static braking torque does not affect the winch maximum static line pull which must be considered 125% of the nominal line pull at first layer.

## Line pull for Certified Winch Version: SI

Rope Diameter	Line Pull (according to DNVGL) [kg]				Line Pull (according to ABS) [kg]			
	Cargo Winch		Lifting of Personnell Winch		Cargo Winch		Lifting of Personnell Winch	
	Last Layer	First Layer	Last Layer	First Layer	Last Layer	First Layer	Last Layer	First Layer
Ø 14 [mm]	3013 (5) <sup>(1)</sup>	3900	1159 (5) <sup>(1)</sup>	1500	3013 (5) <sup>(1)</sup>	3900	1429 (5) <sup>(1)</sup>	1850
Ø 16 [mm]	3998 (4) <sup>(1)</sup>	5000	1199 (4) <sup>(1)</sup>	1500	3518 (4) <sup>(1)</sup>	4400	1479 (4) <sup>(1)</sup>	1850
Ø 18 [mm]	4213 (3) <sup>(1)</sup>	5000	1264 (3) <sup>(1)</sup>	1500	3707 (3) <sup>(1)</sup>	4400	1559 (3) <sup>(1)</sup>	1850

## Line pull for Certified Winch Version: USC

Rope Diameter	Line Pull (according to DNVGL) [lbf]				Line Pull (according to ABS) [lbf]			
	Cargo Winch		Lifting of Personnell Winch		Cargo Winch		Lifting of Personnell Winch	
	Last Layer	First Layer	Last Layer	First Layer	Last Layer	First Layer	Last Layer	First Layer
Ø 0.55 [in]	6696 (5) <sup>(1)</sup>	8667	2576 (5) <sup>(1)</sup>	3333	6696 (5) <sup>(1)</sup>	8667	3150 (5) <sup>(1)</sup>	4111
Ø 0.63 [in]	8884 (4) <sup>(1)</sup>	11111	2664 (4) <sup>(1)</sup>	3333	7818 (4) <sup>(1)</sup>	9778	3261 (4) <sup>(1)</sup>	4111
Ø 0.71 [in]	9362 (3) <sup>(1)</sup>	11111	2808 (3) <sup>(1)</sup>	3333	8238 (3) <sup>(1)</sup>	9778	3437 (3) <sup>(1)</sup>	4111

The line pull listed above are just for reference, for this application is strongly recommended to fill up the Winch Application Data Form available at the end of this catalogue and consult the Dana area contact person for final selection and validation.

## Other Ropes available - standard

Working layer			1	2	3	4	5	6
Rope Diameter Ø 14 [mm]	Rope length	[m]	25	50	79	109	141	174
Rope Diameter Ø 18 [mm]	Rope length	[m]	19	40	63	87	114	-

Working layer			1	2	3	4	5	6
Rope Diameter Ø 0.55 [in]	Rope length	[ft]	82	167	261	357	464	572
Rope Diameter Ø 0.71 [in]	Rope length	[ft]	64	131	208	287	376	-

Last indicated Layer is intended only as Storage

## Other Ropes available - extended

Working layer			1	2	3	4	5	6
Rope Diameter Ø 14 [mm]	Rope length	[m]	37	77	121	166	215	265
Rope Diameter Ø 16 [mm]	Rope length	[m]	33	68	107	147	192	238
Rope Diameter Ø 18 [mm]	Rope length	[m]	29	61	96	133	174	-

Working layer			1	2	3	4	5	6
Rope Diameter Ø 0.55 [in]	Rope length	[ft]	124	254	397	544	705	871
Rope Diameter Ø 0.63 [in]	Rope length	[ft]	109	224	352	485	631	781
Rope Diameter Ø 0.71 [in]	Rope length	[ft]	97	201	317	438	573	-

Last indicated Layer is intended only as Storage

<sup>(1)</sup> Last working layer

Axial Piston Motor Fixed Displacement

Maximum Line pull at first layer

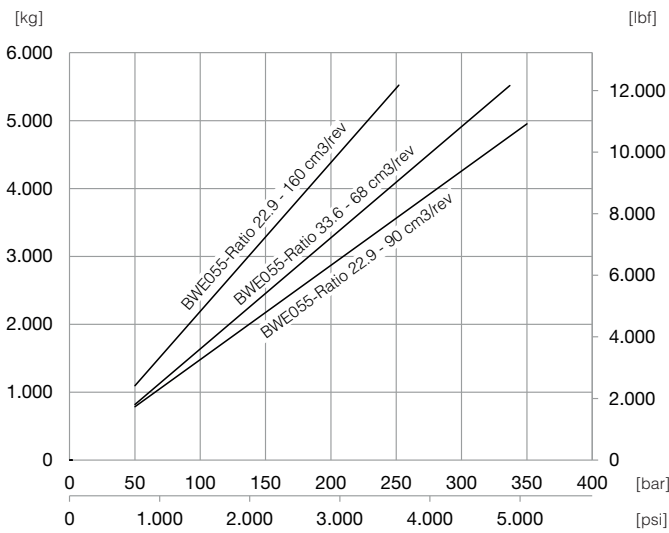

Maximum Speed at first layer

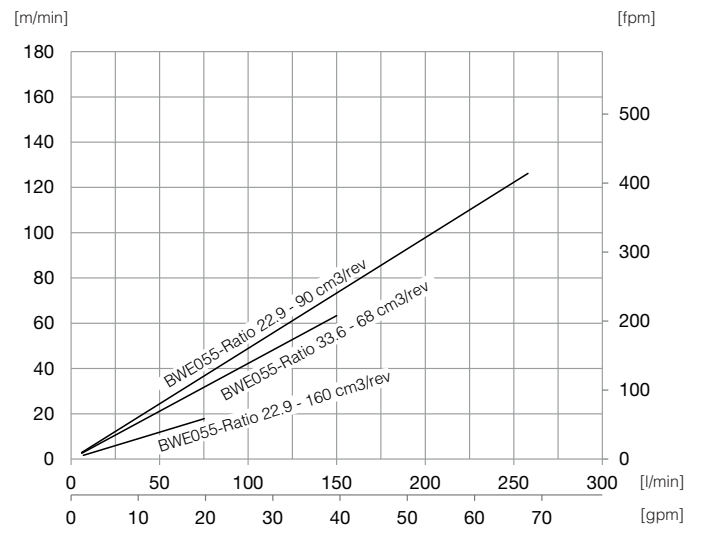

Axial Piston Motor Variable Displacement

Maximum Line pull at first layer

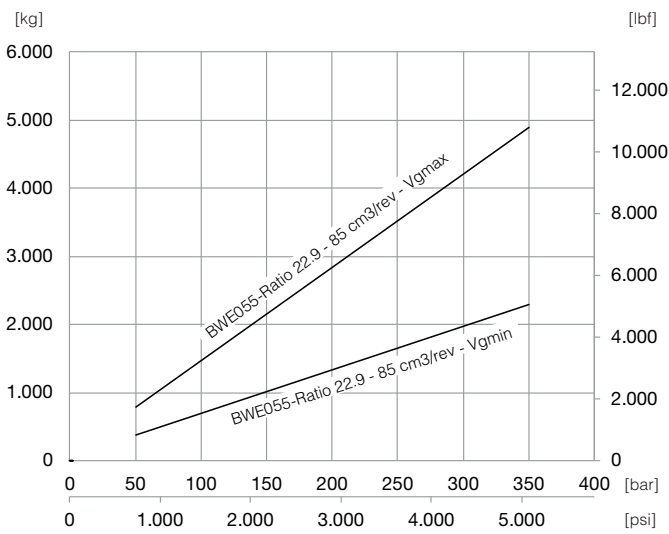

Maximum Speed at first layer

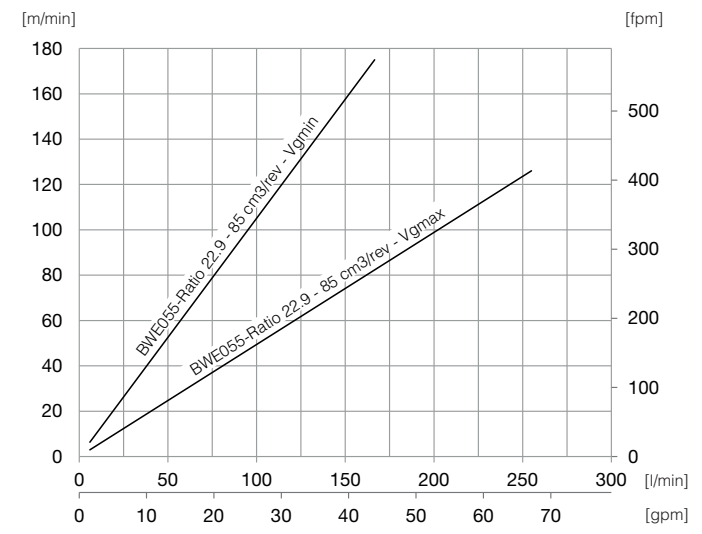

$V_{g_{max}} = 85 \text{ cm}^3/\text{rev}$  [5.17 in<sup>3</sup>/rev]  
 $V_{g_{min}} = 40 \text{ cm}^3/\text{rev}$  [2.43 in<sup>3</sup>/rev]

$V_{g_{max}} = 85 \text{ cm}^3/\text{rev}$  [5.17 in<sup>3</sup>/rev] - Max 255 l/min [67 gpm] allowed  
 $V_{g_{min}} = 40 \text{ cm}^3/\text{rev}$  [2.43 in<sup>3</sup>/rev] - Max 166 l/min [44 gpm] allowed

**Note:**

- All data shown in this page are ONLY FOR INFORMATION. The actual data will be issued according to Customer application and Duty Cycle.



**BREVINI<sup>®</sup>**

*Motion Systems*

**Line Pull at first Layer up to:**  
**7.000 [kg]**  
**15.400 [lbf]**

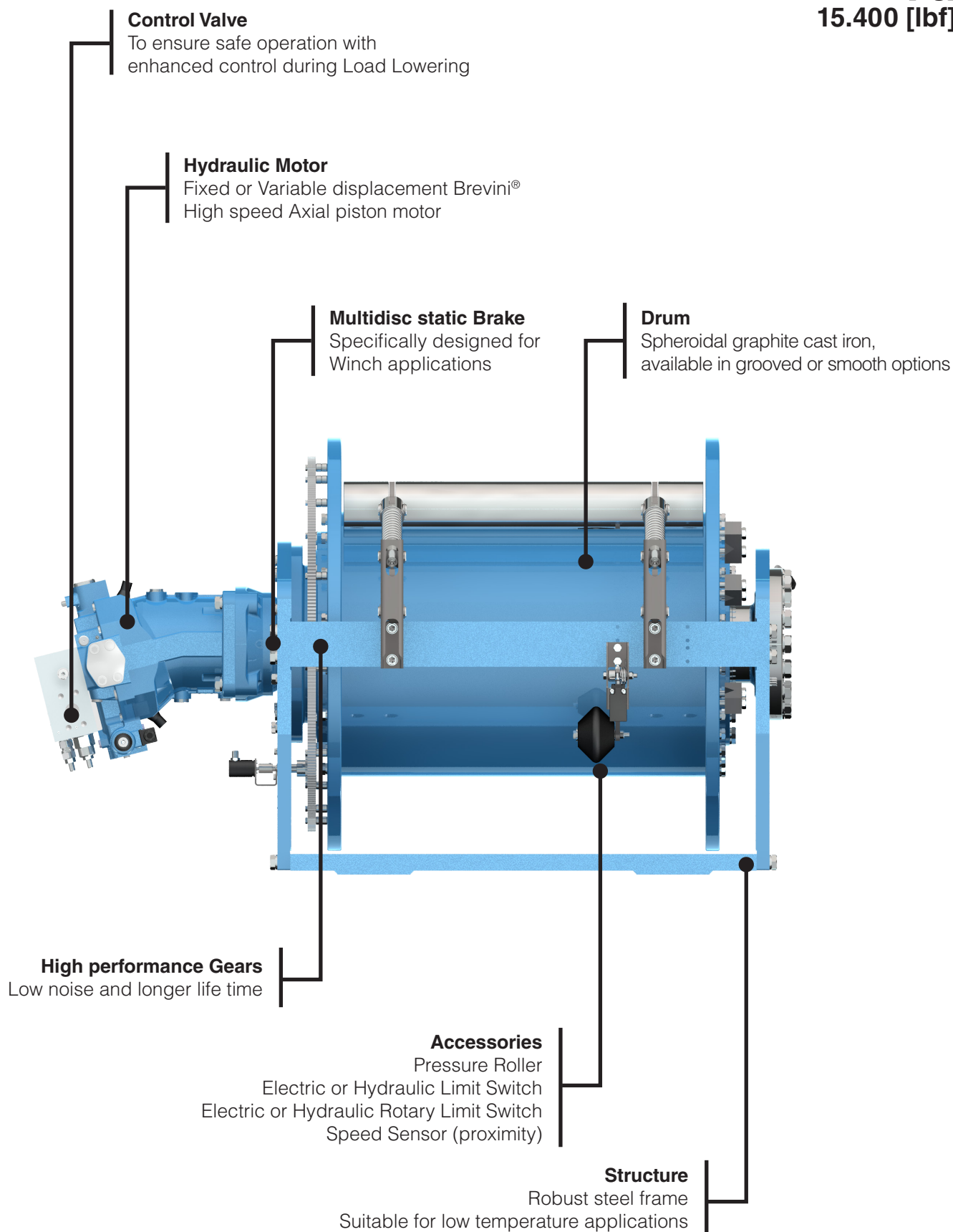

Brevini® Hydraulic Axial Piston Motor

	Motor type	Displacement	L
Fixed Displacement	SH11CR090 <sup>(1)</sup>	90 cm <sup>3</sup> /rev [5.47 in <sup>3</sup> /rev]	239 mm [9.409 in]
Fixed Displacement	SH11CR125 <sup>(1)</sup>	125 cm <sup>3</sup> /rev [7.61 in <sup>3</sup> /rev]	265 mm [10.433 in]
Variable Displacement	SH9V115 <sup>(1)</sup>	115 cm <sup>3</sup> /rev [7.00 in <sup>3</sup> /rev]	408 mm [16.062 in]
With NO Motor	Universal Input Flange 00	-	6.0 mm [0.236 in]

Winch - standard <sup>(3)</sup>

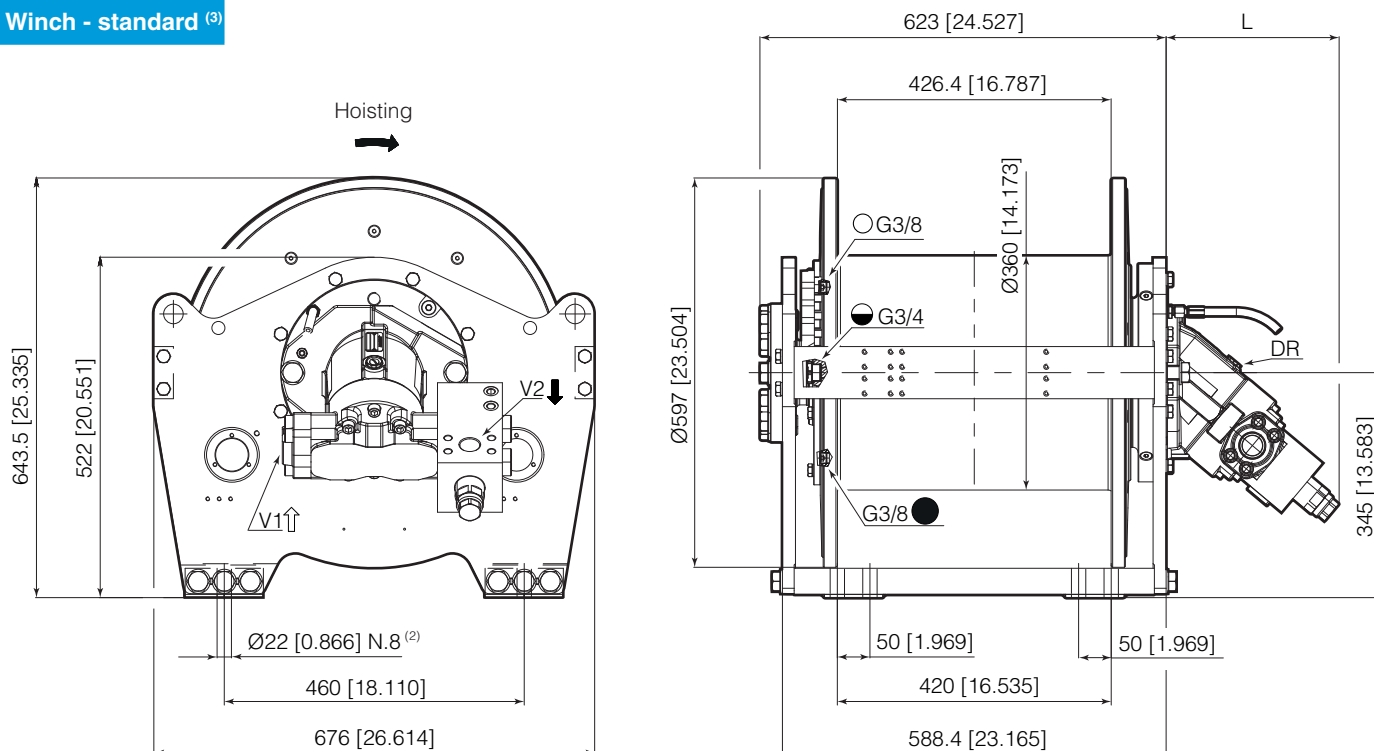

Winch - extended <sup>(3)</sup>

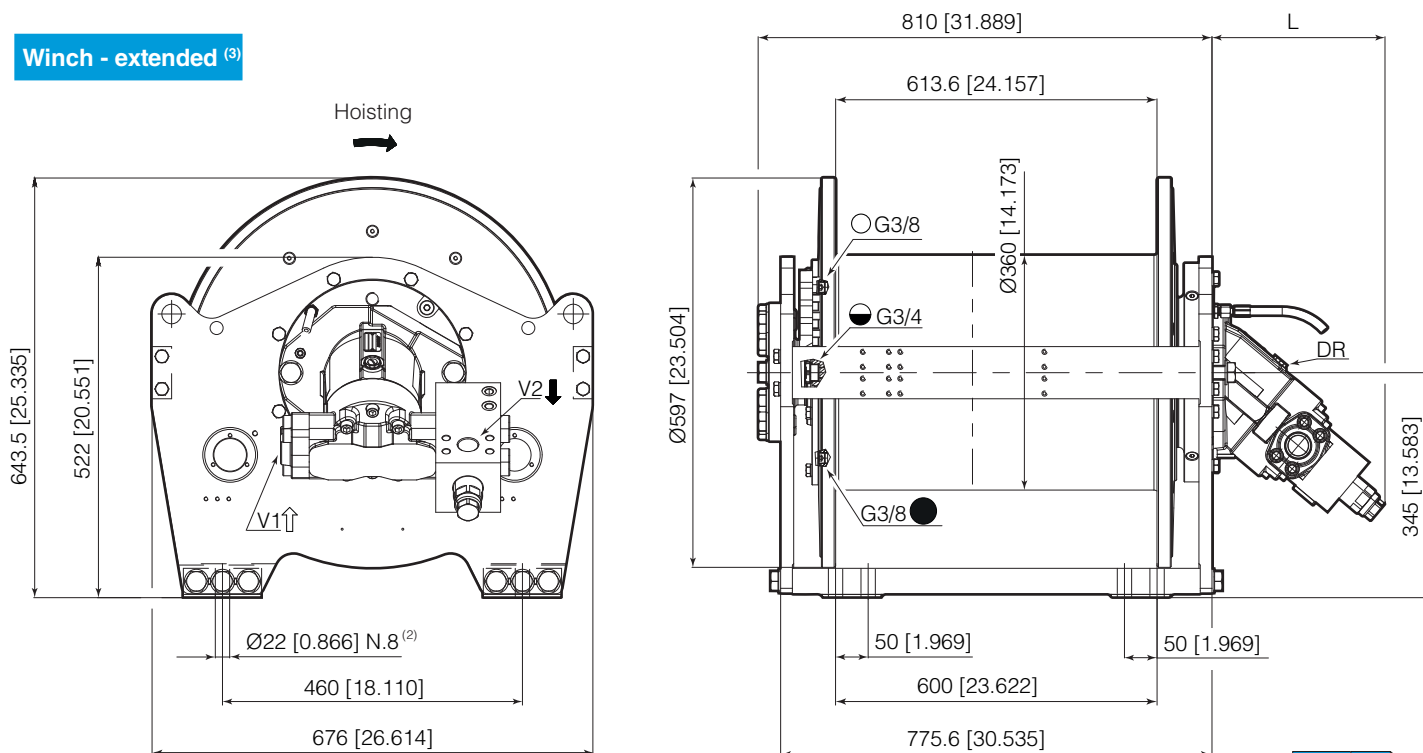

<sup>(1)</sup> As Standard with single overcenter valve, double overcenter valve available on request.

<sup>(2)</sup> N. 4 bolts for DNV certified version only. N. 8 bolts for other versions.

<sup>(3)</sup> Catalogue dimensions only for reference, see dimensional drawing for detailed information



Brevini® Hydraulic Axial Piston Motor for Lifting of Personnel Winches

	Motor type	Displacement	L
Fixed Displacement	SH11CR090 <sup>(1)</sup>	90 cm <sup>3</sup> /rev [5.47 in <sup>3</sup> /rev]	239 mm [9.409 in]
Fixed Displacement	SH11CR125 <sup>(1)</sup>	125 cm <sup>3</sup> /rev [7.61 in <sup>3</sup> /rev]	265 mm [10.433 in]
Variable Displacement	SH9V115 <sup>(1)</sup>	115 cm <sup>3</sup> /rev [7.00 in <sup>3</sup> /rev]	408 mm [16.062 in]
With NO Motor	Universal Input Flange 00	-	6.0 mm [0.236 in]

Lifting of Personnel Winch - standard <sup>(4)</sup>

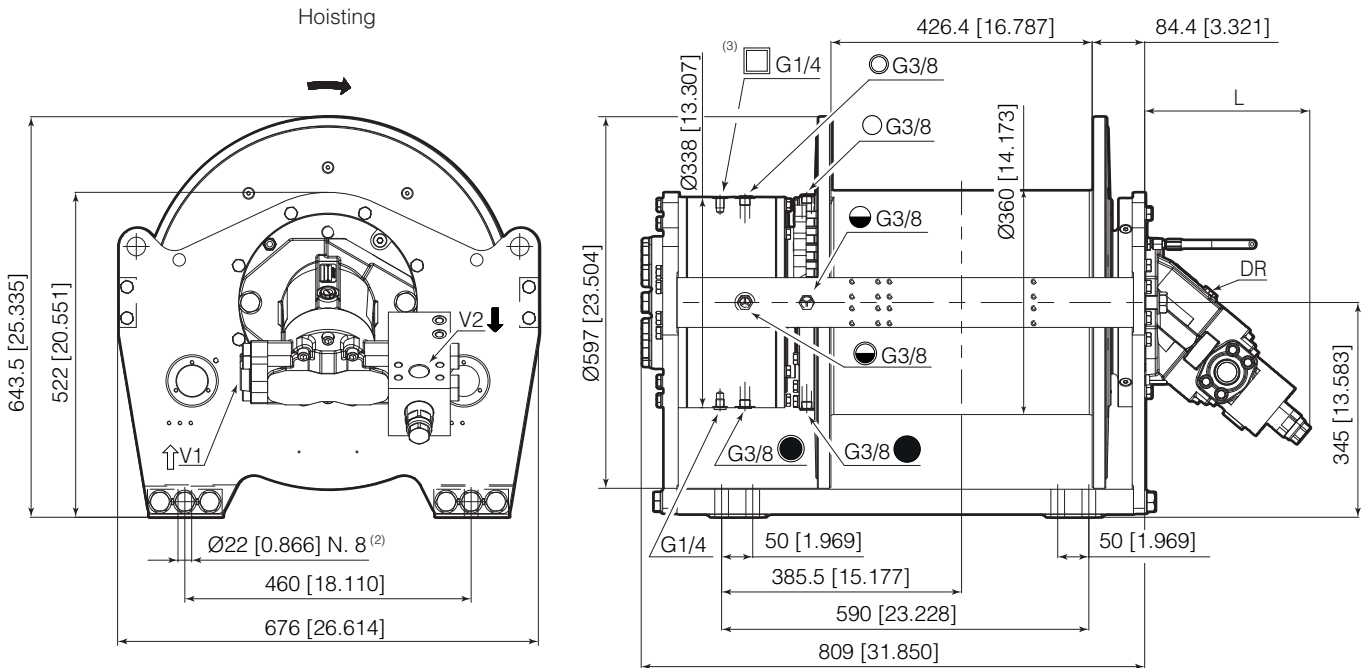

Lifting of Personnel Winch - extended <sup>(4)</sup>

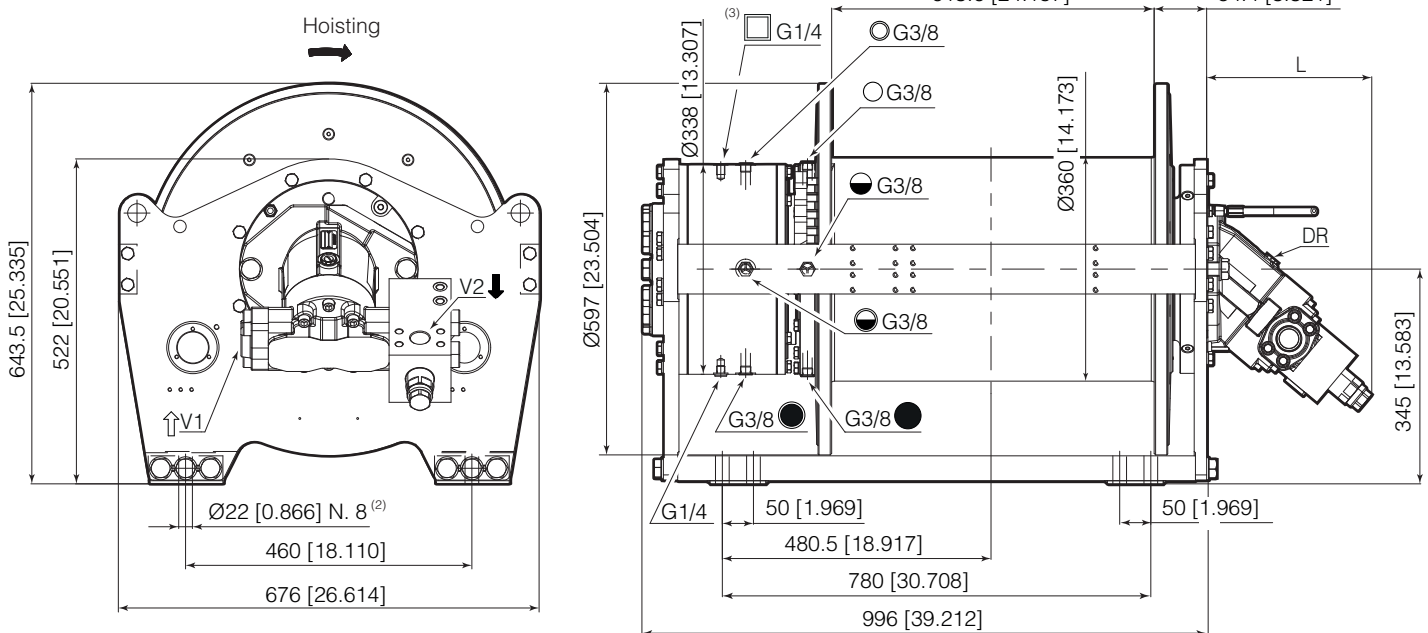

<sup>(1)</sup> As Standard with single overcenter valve, double overcenter valve available on request.

<sup>(2)</sup> N. 4 bolts for DVN certified version only. N. 8 bolts for other versions.

<sup>(3)</sup> Lifting of personnel brake release pressure (Release / Max) 39/300 bar [566/4355 psi]

<sup>(4)</sup> Catalogue dimensions only for reference, see dimensional drawing for detailed information

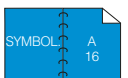

### Motor Drum Winch

Available on request .

- with or without motor
- smooth or grooved drum
- customized drum length
- different rope diameter

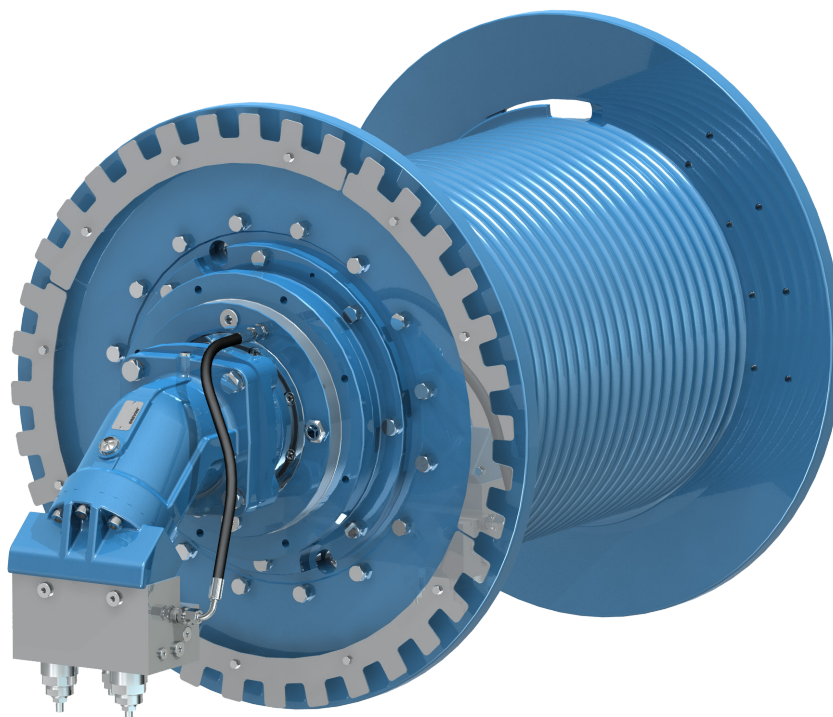

### Our Standard Configurations

Hydraulic Motor Fixed Displacement	SH11CR090	90 [cm <sup>3</sup> /rev]	5.47 [in <sup>3</sup> /rev]
	SH11CR125	125 [cm <sup>3</sup> /rev]	7.61 [in <sup>3</sup> /rev]
Hydraulic Motor Variable Displacement	SH9V115	115 [cm <sup>3</sup> /rev]	7.00 [in <sup>3</sup> /rev]
Ratio		33.6	
		22.9	
Drum	standard	Smooth Drum Special Grooved Drum <sup>(1)</sup>	
	extended	Smooth Drum Special Grooved Drum <sup>(1)</sup>	
Rope		Ø 18 [mm]	Ø 0.71 [in]
		Ø 20 [mm]	Ø 0.78 [in]
		Ø 22 [mm]	Ø 0.86 [in]

<sup>(1)</sup> Left hand grooving as Standard only with rope diameter Ø 20 mm [0.78 in]. Right handal grooving on request. Other rope diameter available on request.



International System of Units: SI

BWE070-SD20..-01-22.9-APF125

Working layer		1	2	3	4	5	6
		<b>Storage length</b>					
Line pull	[kg]	7000	6430	5940	5520	5150	-
Rope speed	[m/min]	58	64	69	74	80	-
Rope length	[m]	24	49	78	108	141	175
Brevini® Motor	SH11CR125	Advised rope diameter		20		[mm]	
Starting lifting pressure	395 [bar]	Oil fill / drain plug		G3/8		T	
Operating pressure	335 [bar]	Lifting / Lowering port		G1		V1 / V2	
Operating oil flow at the motor	150 [l/min]	Motor drain port		G1/2		DR	
Minimum oil flow at the motor	8.0 [l/min]	Static braking torque <sup>(1)</sup>		778		[Nm]	
Gear ratio	22.9 [i]	Brake release pressure (Release/Max)		31 / 350		[bar]	
Winch mechanisms classification in agreement with F.E.M. (1.001) (Third edition revised on 01.10.1998)						M5 (T5-L2)	n <sub>2</sub> =15 [rpm]

BWE070/SH11CR125		Weight [kg]		Oil [l]	
		Cargo	LoP	Cargo	LoP
	Standard	506	641	8	9.8
	Extended drum	564	699	14.2	16

United States Customary Units: USC

BWE070-SD20..-01-22.9-APF125

Working layer		1	2	3	4	5	6
		<b>Storage length</b>					
Line pull	[lbf]	15400	14180	13100	12170	11370	-
Rope speed	[fpm]	193	210	227	245	262	-
Rope length	[ft]	80	163	258	355	464	575
Brevini® Motor	SH11CR125	Advised rope diameter		0.78		[in]	
Starting lifting pressure	5770 [psi]	Oil fill / drain plug		G3/8		T	
Operating pressure	4815 [psi]	Lifting / Lowering port		G1		V1 / V2	
Operating oil flow at the motor	40 [gpm]	Motor drain port		G1/2		DR	
Minimum oil flow at the motor	2.11 [gpm]	Static braking torque <sup>(1)</sup>		573		[ft-lbf]	
Gear ratio	22.9 [i]	Brake release pressure (Release/Max)		450 / 5080		[psi]	
Winch mechanisms classification in agreement with F.E.M. (1.001) (Third edition revised on 01.10.1998)						M5 (T5-L2)	n <sub>2</sub> =15 [rpm]

BWE070/SH11CR125		Weight [lbs]		Oil [gal]	
		Cargo	LoP	Cargo	LoP
	Standard	1115	1413	2.11	2.59
	Extended drum	1243	1541	3.75	4.23

**Note:**

- For safety reasons always keep at least 3 wraps of rope wrapped on the drum.
- Technical features may change with no previous notice from the manufacturer.
- The MBL of the Rope must be verified according to the requested Safety Factors.
- All data shown in this page are ONLY FOR INFORMATION. The actual data will be issued according to Customer application and Duty Cycle.

<sup>(1)</sup> Static braking torque does not affect the winch maximum static line pull which must be considered 125% of the nominal line pull at first layer.

## Line pull for Certified Winch Version: SI

Rope Diameter	Line Pull (according to DNVGL) [kg]				Line Pull (according to ABS) [kg]			
	Cargo Winch		Lifting of Personnell Winch		Cargo Winch		Lifting of Personnell Winch	
	Last Layer	First Layer	Last Layer	First Layer	Last Layer	First Layer	Last Layer	First Layer
Ø 18 [mm]	3923 (5) <sup>(1)</sup>	5200	1509 (5) <sup>(1)</sup>	2000	3923 (5) <sup>(1)</sup>	5200	1811 (5) <sup>(1)</sup>	2400
Ø 20 [mm]	5040 (4) <sup>(1)</sup>	6400	1575 (4) <sup>(1)</sup>	2000	4804 (4) <sup>(1)</sup>	6100	1890 (4) <sup>(1)</sup>	2400
Ø 22 [mm]	5348 (3) <sup>(1)</sup>	6400	1671 (3) <sup>(1)</sup>	2000	5097 (3) <sup>(1)</sup>	6100	2005 (3) <sup>(1)</sup>	2400

## Line pull for Certified Winch Version: USC

Rope Diameter	Line Pull (according to DNVGL) [lbf]				Line Pull (according to ABS) [lbf]			
	Cargo Winch		Lifting of Personnell Winch		Cargo Winch		Lifting of Personnell Winch	
	Last Layer	First Layer	Last Layer	First Layer	Last Layer	First Layer	Last Layer	First Layer
Ø 0.71 [in]	8718 (5) <sup>(1)</sup>	11556	3353 (5) <sup>(1)</sup>	4444	8718 (5) <sup>(1)</sup>	11556	4024 (5) <sup>(1)</sup>	5333
Ø 0.78 [in]	11200 (4) <sup>(1)</sup>	14222	3500 (4) <sup>(1)</sup>	4444	10676 (4) <sup>(1)</sup>	13556	4200 (4) <sup>(1)</sup>	5333
Ø 0.86 [in]	11884 (3) <sup>(1)</sup>	14222	3713 (3) <sup>(1)</sup>	4444	11327 (3) <sup>(1)</sup>	13556	4456 (3) <sup>(1)</sup>	5333

The line pull listed above are just for reference, for this application is strongly recommended to fill up the Winch Application Data Form available at the end of this catalogue and consult the Dana area contact person for final selection and validation.

## Other Ropes available - standard

Working layer			1	2	3	4	5	6
Rope Diameter Ø 18 [mm]	Rope length	[m]	27	55	86	118	154	190
Rope Diameter Ø 22 [mm]	Rope length	[m]	22	45	72	99	130	-

Working layer			1	2	3	4	5	6
Rope Diameter Ø 0.71 [in]	Rope length	[ft]	88	180	283	389	506	626
Rope Diameter Ø 0.86 [in]	Rope length	[ft]	73	149	237	327	429	-

Last indicated Layer is intended only as Storage

## Other Ropes available - extended

Working layer			1	2	3	4	5	6
Rope Diameter Ø 18 [mm]	Rope length	[m]	38	79	124	171	223	276
Rope Diameter Ø 20 [mm]	Rope length	[m]	35	72	113	157	204	254
Rope Diameter Ø 22 [mm]	Rope length	[m]	32	66	104	144	189	-

Working layer			1	2	3	4	5	6
Rope Diameter Ø 0.71 [in]	Rope length	[ft]	127	261	410	564	733	907
Rope Diameter Ø 0.78 [in]	Rope length	[ft]	115	237	373	515	672	834
Rope Diameter Ø 0.86 [in]	Rope length	[ft]	105	217	343	475	622	-

Last indicated Layer is intended only as Storage

<sup>(1)</sup> Last working layer

Axial Piston Motor Fixed Displacement

Maximum Line pull at first layer

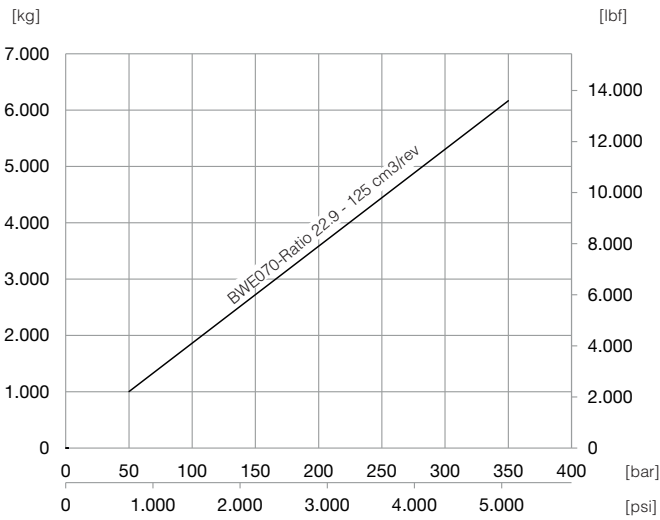

Maximum Speed at first layer

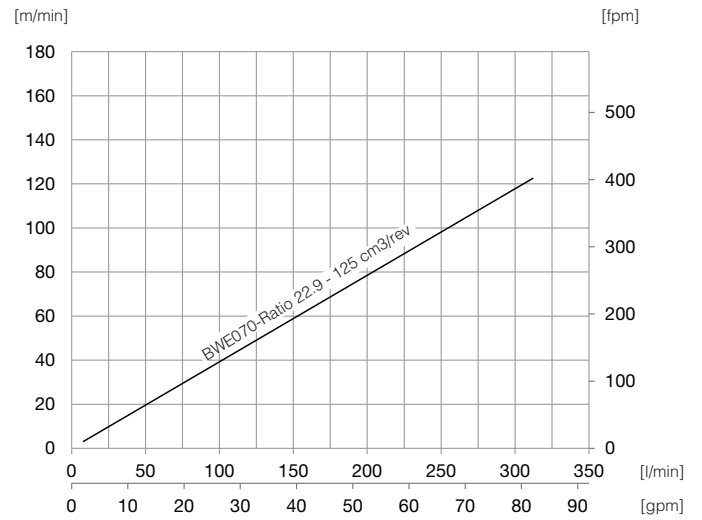

Axial Piston Motor Variable Displacement

Maximum Line pull at first layer

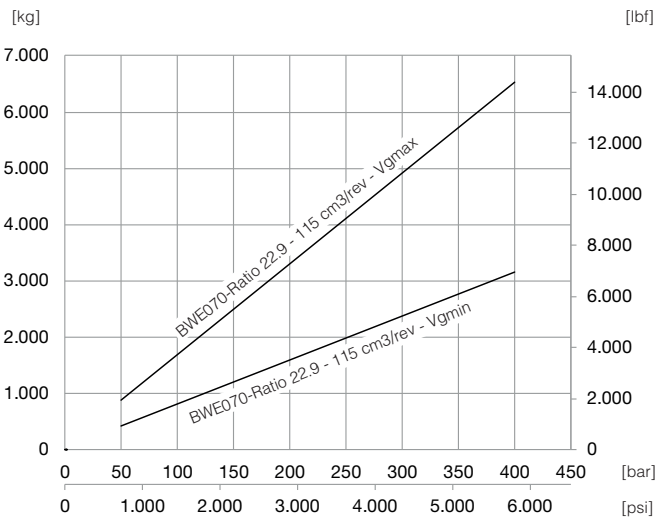

Maximum Speed at first layer

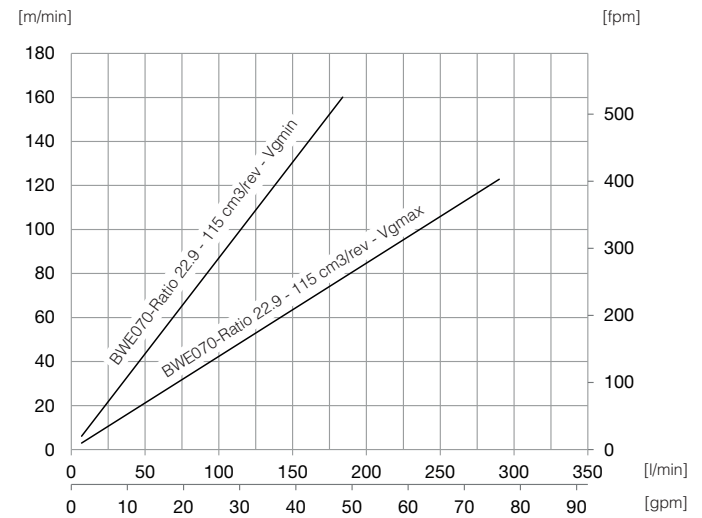

$V_{g_{max}} = 115 \text{ cm}^3/\text{rev}$  [7.00 in<sup>3</sup>/rev]  
 $V_{g_{min}} = 56 \text{ cm}^3/\text{rev}$  [4.40 in<sup>3</sup>/rev]

$V_{g_{max}} = 115 \text{ cm}^3/\text{rev}$  [7.00 in<sup>3</sup>/rev] - Max 290 l/min [76 gpm] allowed  
 $V_{g_{min}} = 56 \text{ cm}^3/\text{rev}$  [4.40 in<sup>3</sup>/rev] - Max 183 l/min [48 gpm] allowed

**Note:**

- All data shown in this page are ONLY FOR INFORMATION. The actual data will be issued according to Customer application and Duty Cycle.



**BREVINI<sup>®</sup>**

*Motion Systems*

Line Pull at first Layer up to:  
8.500 [kg]  
18.700 [lbf]

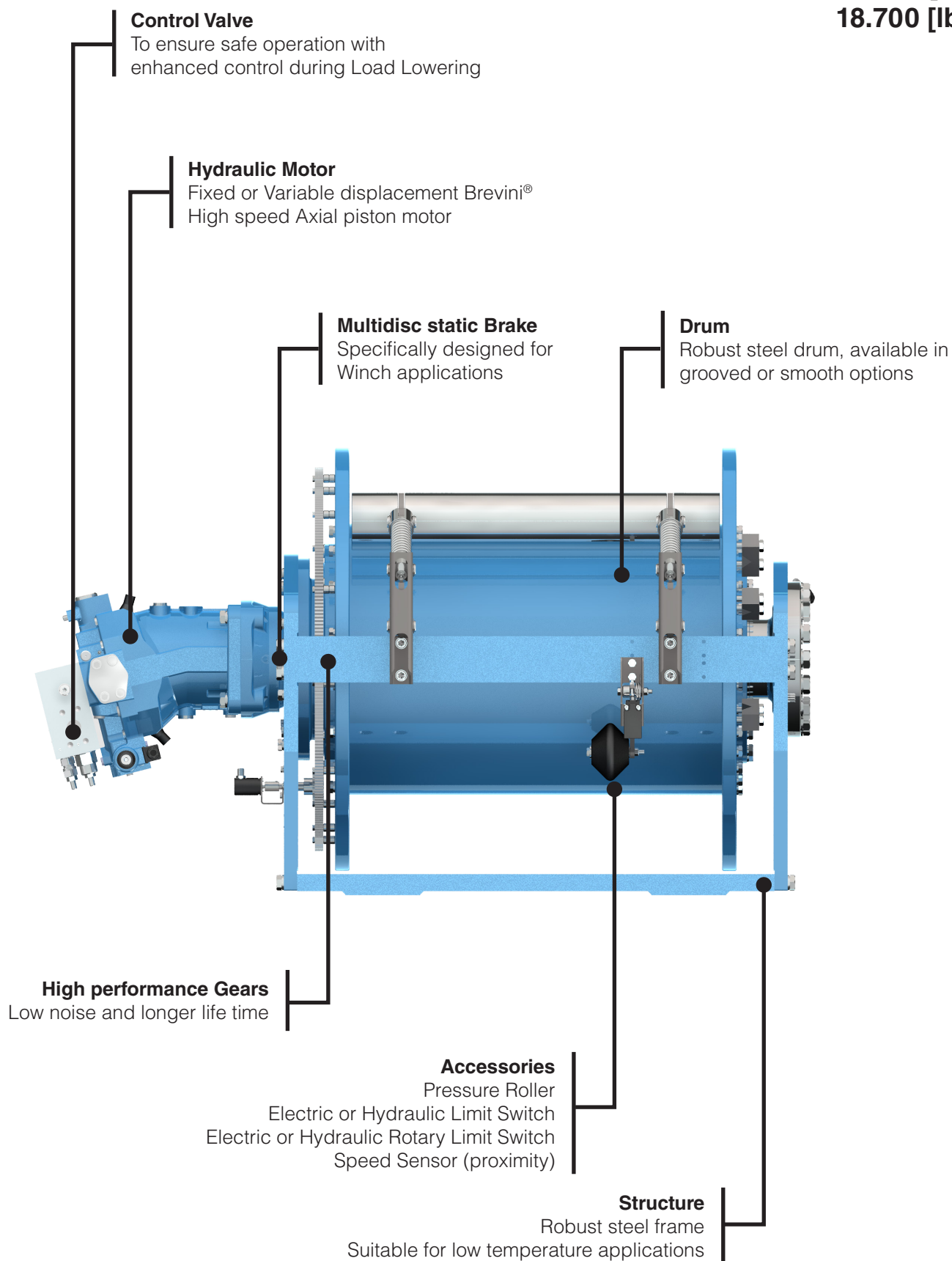

Brevini® Hydraulic Axial Piston Motor

	Motor Type	Displacement	L
Fixed Displacement	SH11C075	77.82 cm <sup>3</sup> /rev [4.747 in <sup>3</sup> /rev]	286 mm [11.3 in]
Variable Displacement	SH9V085	85.3 cm <sup>3</sup> /rev [5.203 in <sup>3</sup> /rev]	380 mm [15 in]
With NO Motor	Universal Input Flange 00	-	9.5 mm [0.374 in]

Winch <sup>(2)</sup>

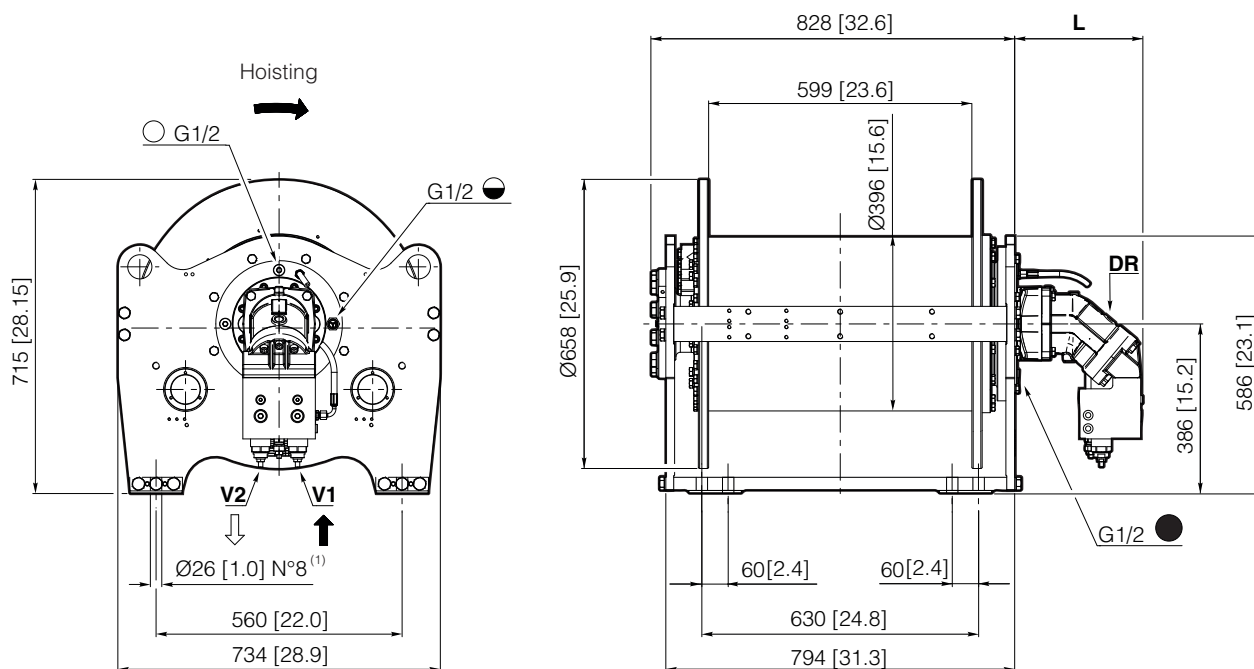

<sup>(1)</sup> N. 8 bolts for ABS certified version only. N. 4 bolts for other versions.

<sup>(2)</sup> Catalogue dimensions only for reference, see dimensional drawing for detailed information

Brevini® Hydraulic Axial Piston Motor for Lifting of Personnel Winches

	Motor Type	Displacement	L
Fixed Displacement	SH11C075	77.82 cm <sup>3</sup> /rev [4.747 in <sup>3</sup> /rev]	286 mm [11.3 in]
Variable Displacement	SH9V085	85.3 cm <sup>3</sup> /rev [5.203 in <sup>3</sup> /rev]	380 mm [15 in]
With NO Motor	Universal Input Flange 00	-	9.5 mm [0.374 in]

Lifting of Personnel Winch <sup>(3)</sup>

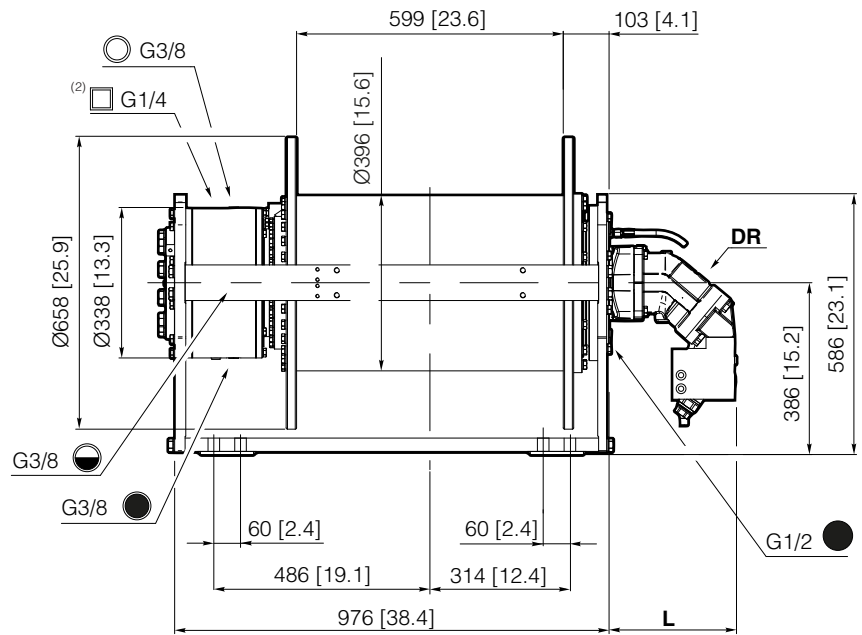
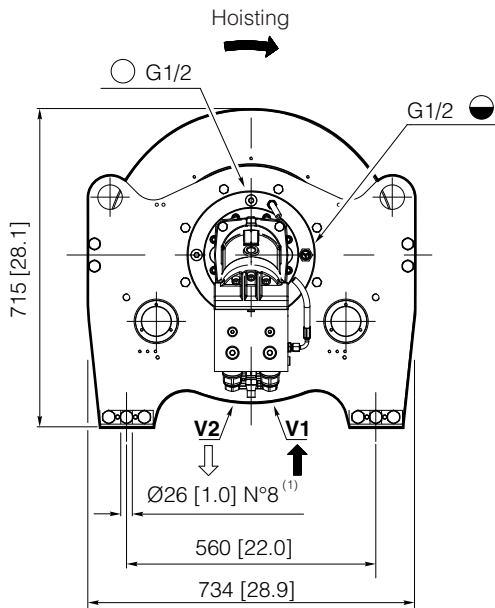

<sup>(1)</sup> N. 8 bolts for ABS certified version only, N. 4 bolts for other versions.

<sup>(2)</sup> Lifting of personnel brake release pressure (Release / Max) 50/300 bar [725/4355 psi]

<sup>(3)</sup> Catalogue dimensions only for reference, see dimensional drawing for detailed information

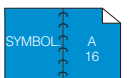

### Motor Drum Winch

Available on request .

- with or without motor
- smooth or grooved drum
- customized drum length
- different rope diameter

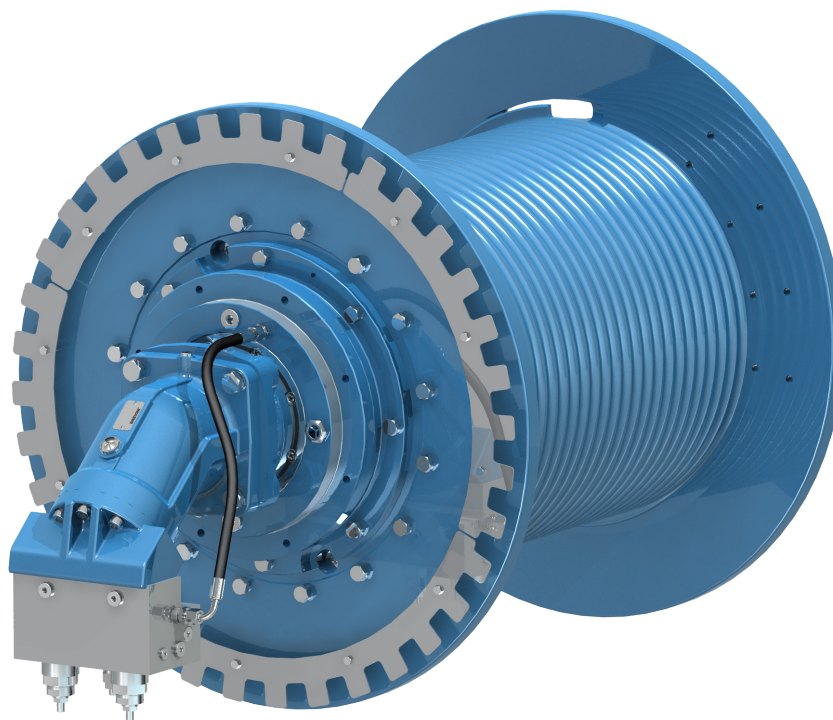

### Our Standard Configurations

<b>Hydraulic Motor Fixed Displacement</b>	<b>SH11C075</b>	77.82 [cm <sup>3</sup> /rev]	4.74 [in <sup>3</sup> /rev]
<b>Hydraulic Motor Variable Displacement</b>	<b>SH9V085</b>	85.3 [cm <sup>3</sup> /rev]	5.2 [in <sup>3</sup> /rev]
<b>Ratio</b>		49.4	
		81.0	
<b>Drum</b>	<b>standard</b>	Smooth Drum Special Grooved Drum <sup>(1)</sup>	
<b>Rope</b>		Ø 20 [mm] Ø 22 [mm] Ø 24 [mm]	Ø 0.78 [in] Ø 0.86 [in] Ø 0.94 [in]

<sup>(1)</sup> Left hand grooving as Standard only with rope diameter Ø 22 mm [0.86 in]. Right handal grooving on request. Other rope diameter available on request.



## International System of Units: SI

BWE085-SD22..-01-81-APF075

Working layer		1	2	3	4	5	6	
								Storage length
Line pull	[kg]	8500	7820	7230	6720	6270	-	
Rope speed	[m/min]	29	32	34	37	39	-	
Rope length	[m]	34	71	112	154	202	250	
Brevini® Motor	SH11C075	Advised rope diameter				22	[l]	
Starting lifting pressure	245 [bar]	Oil fill / drain plug				G1/2	T	
Operating pressure	210 [bar]	Lifting / Lowering port				G1	V1 / V2	
Operating oil flow at the motor	150 [l/min]	Motor drain port				G1/2	DR	
Minimum oil flow at the motor	6.0 [l/min]	Static braking torque <sup>(1)</sup>				1172	[Nm]	
Gear ratio	81.0 [i]	Brake release pressure (Release/Max)				26 / 350	[bar]	
Winch mechanisms classification in agreement with F.E.M. (1.001) (Third edition revised on 01.10.1998)						M5 (T5-L2)	n <sub>2</sub> =15 [rpm]	

	Weight [kg]		Oil [l]	
	Cargo	LoP	Cargo	LoP
<b>BWE085-SD22..-01-81-APF075</b>	639	774	21	22.5

## United States Customary Units: USC

BWE085-SD22..-01-81-APF075

Working layer		1	2	3	4	5	6	
								Storage length
Line pull	[lbf]	18800	17250	15940	14810	13830	-	
Rope speed	[fpm]	96	105	113	122	131	-	
Rope length	[ft]	114	233	368	507	662	822	
Brevini® Motor	SH11C075	Advised rope diameter				0.86	[in]	
Starting lifting pressure	3610 [psi]	Oil fill / drain plug				G1/2	T	
Operating pressure	3010 [psi]	Lifting / Lowering port				G1	V1 / V2	
Operating oil flow at the motor	40 [gpm]	Motor drain port				G1	DR	
Minimum oil flow at the motor	1.58 [gpm]	Static braking torque <sup>(1)</sup>				864	[ft·lbf]	
Gear ratio	81.0 [i]	Brake release pressure (Release/Max)				380 / 5080	[psi]	
Winch mechanisms classification in agreement with F.E.M. (1.001) (Third edition revised on 01.10.1998)						M5 (T5-L2)	n <sub>2</sub> =15 [rpm]	

	Weight [lbs]		Oil [gal]	
	Cargo	LoP	Cargo	LoP
<b>BWE085-SD22..-01-81-APF075</b>	1409	1706	5.55	5.94

**Note:**

- For safety reasons always keep at least 3 wraps of rope wrapped on the drum.
- Technical features may change with no previous notice from the manufacturer.
- The MBL of the Rope must be verified according to the requested Safety Factors.
- All data shown in this page are ONLY FOR INFORMATION. The actual data will be issued according to Customer application and Duty Cycle.

<sup>(1)</sup> Static braking torque does not affect the winch maximum static line pull which must be considered 125% of the nominal line pull at first layer.

## Line pull for Certified Winch Version: SI

Rope Diameter	Line Pull (according to DNVGL) [kg]				Line Pull (according to ABS) [kg]			
	Cargo Winch		Lifting of Personnell Winch		Cargo Winch		Lifting of Personnell Winch	
	Last Layer	First Layer	Last Layer	First Layer	Last Layer	First Layer	Last Layer	First Layer
Ø 20 [mm]	4516 (5) <sup>(1)</sup>	6000	1732 (5) <sup>(1)</sup>	2300	4516 (5) <sup>(1)</sup>	6000	2108 (5) <sup>(1)</sup>	2800
Ø 22 [mm]	5335 (4) <sup>(1)</sup>	6800	1811 (4) <sup>(1)</sup>	2300	5355 (4) <sup>(1)</sup>	6800	2205 (4) <sup>(1)</sup>	2800
Ø 24 [mm]	5765 (3) <sup>(1)</sup>	6800	1925 (3) <sup>(1)</sup>	2300	5689 (3) <sup>(1)</sup>	6800	2343 (3) <sup>(1)</sup>	2800

## Line pull for Certified Winch Version: USC

Rope Diameter	Line Pull (according to DNVGL) [lbf]				Line Pull (according to ABS) [lbf]			
	Cargo Winch		Lifting of Personnell Winch		Cargo Winch		Lifting of Personnell Winch	
	Last Layer	First Layer	Last Layer	First Layer	Last Layer	First Layer	Last Layer	First Layer
Ø 0.78 [in]	9956 (5) <sup>(1)</sup>	13227	3818 (5) <sup>(1)</sup>	5070	9956 (5) <sup>(1)</sup>	13227	4647 (5) <sup>(1)</sup>	6172
Ø 0.86 [in]	11761 (4) <sup>(1)</sup>	14991	3992 (4) <sup>(1)</sup>	5070	11805 (4) <sup>(1)</sup>	14991	4861 (4) <sup>(1)</sup>	6172
Ø 0.94 [in]	12709 (3) <sup>(1)</sup>	14991	4243 (3) <sup>(1)</sup>	5070	12542 (3) <sup>(1)</sup>	14991	5165 (3) <sup>(1)</sup>	6172

The line pull listed above are just for reference, for this application is strongly recommended to fill up the Winch Application Data Form available at the end of this catalogue and consult the Dana area contact person for final selection and validation.

## Other Ropes available

Working layer			1	2	3	4	5	6
Rope Diameter Ø 20 [mm]	Rope length	[m]	38	77	122	168	218	270
Rope Diameter Ø 24 [mm]	Rope length	[m]	32	65	104	143	188	-

## Other Ropes available

Working layer			1	2	3	4	5	6
Rope Diameter Ø 0,78 [in]	Rope length	[ft]	124	255	400	551	717	887
Rope Diameter Ø 0,94 [in]	Rope length	[ft]	105	215	341	471	617	-

Last indicated Layer is intended only as Storage

<sup>(1)</sup> Last working layer

Axial Piston Motor Fixed Displacement

Maximum Line pull at first layer

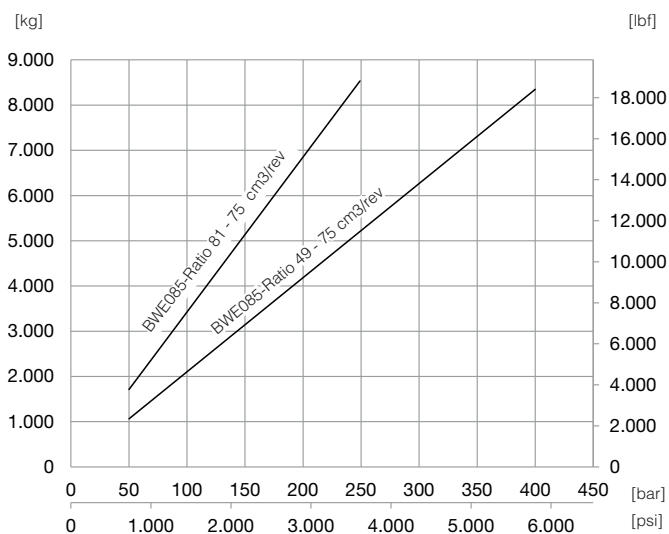

Maximum Speed at first layer

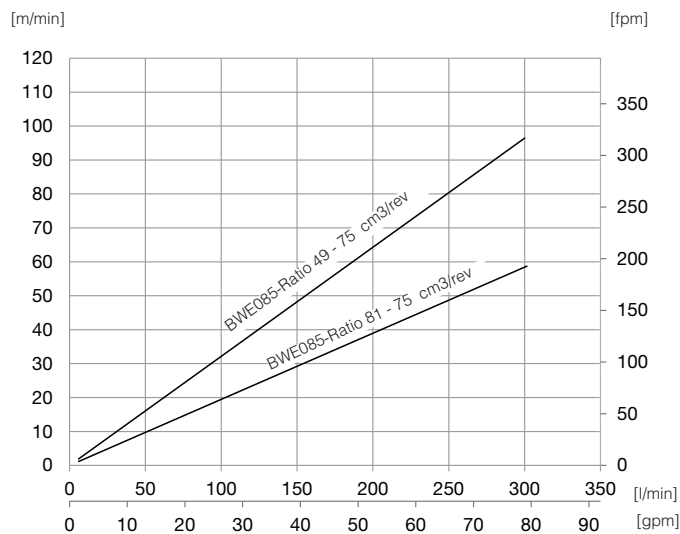

Axial Piston Motor Variable Displacement

Maximum Line pull at first layer

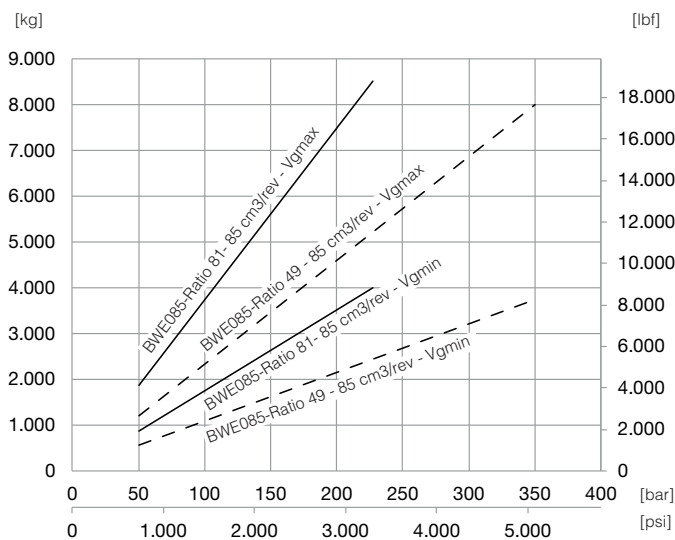

Maximum Speed at first layer

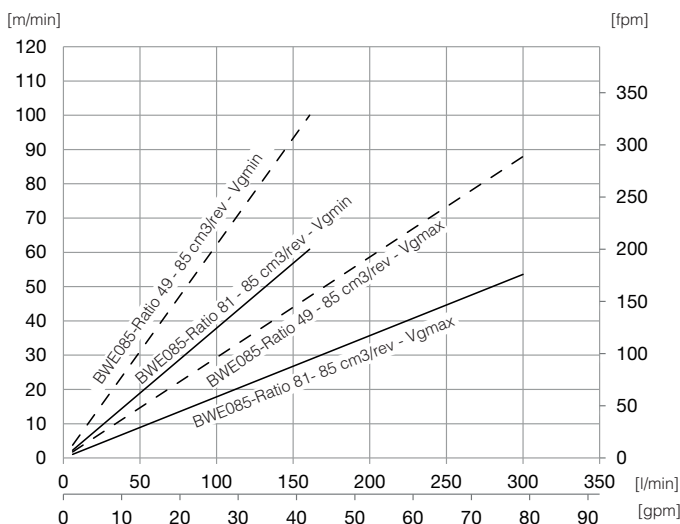

$Vg_{max} = 85 \text{ cm}^3/\text{rev}$  [5.18 in<sup>3</sup>/rev]  
 $Vg_{min} = 40 \text{ cm}^3/\text{rev}$  [2.44 in<sup>3</sup>/rev]

$Vg_{max} = 85 \text{ cm}^3/\text{rev}$  [5.18 in<sup>3</sup>/rev] - Max 300 l/min [80 gpm] allowed  
 $Vg_{min} = 40 \text{ cm}^3/\text{rev}$  [2.44 in<sup>3</sup>/rev] - Max 160 l/min [43 gpm] allowed

Note:

- All data shown in this page are ONLY FOR INFORMATION. The actual data will be issued according to Customer application and Duty Cycle.



**BREVINI<sup>®</sup>**

*Motion Systems*

**Line Pull at first Layer up to:**  
**10.500 [kg]**  
**23.100 [lbf]**

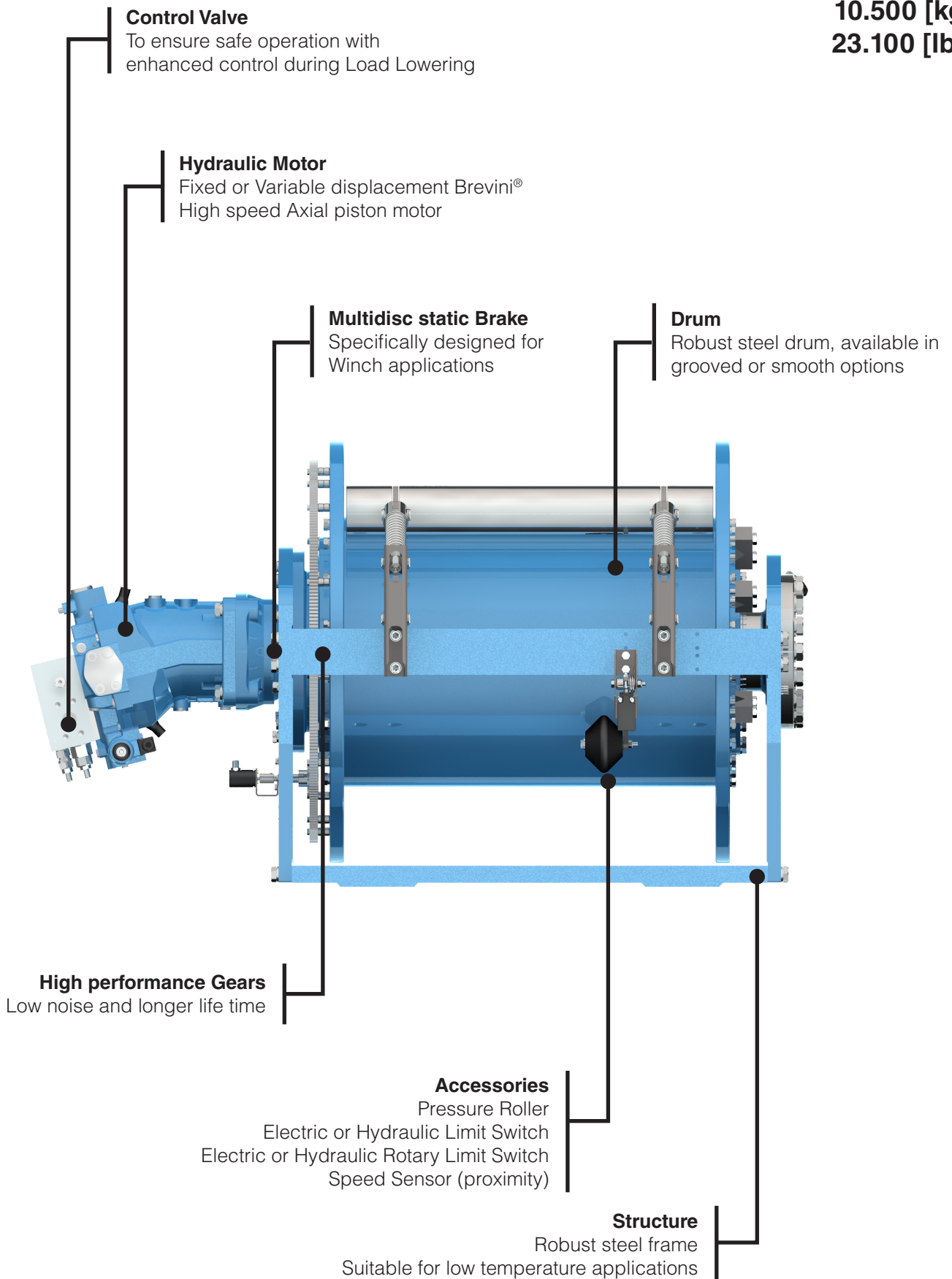

## Brevini® Hydraulic Axial Piston Motor

	Motor Type	Displacement	L
Fixed Displacement	SH11C090	86.23 cm <sup>3</sup> /rev [5.26 in <sup>3</sup> /rev]	286 mm [11.30 in]
Fixed Displacement	SH11C125	124.8 cm <sup>3</sup> /rev [7.613 in <sup>3</sup> /rev]	336 mm [13.20 in]
Variable Displacement	SH9V115	115.7 cm <sup>3</sup> /rev [7.05 in <sup>3</sup> /rev]	432 mm [17.00 in]
With NO Motor	Universal Input Flange 00	-	4.5 mm [0.177 in]

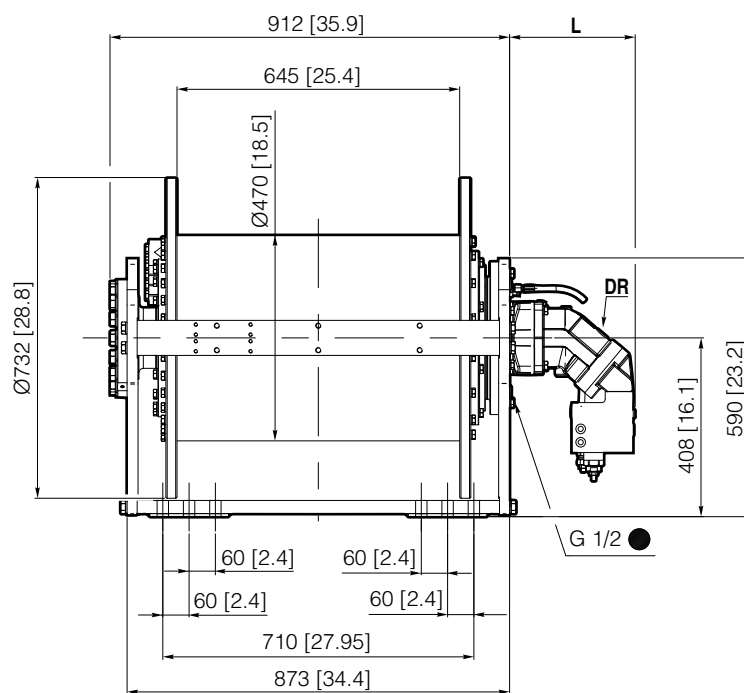
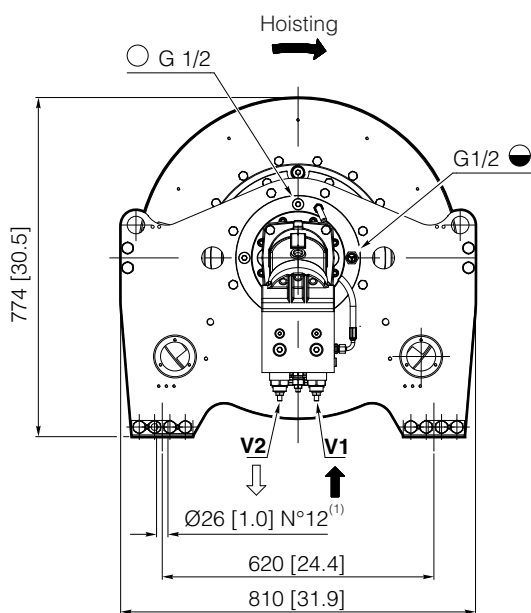
Winch <sup>(2)</sup>

<sup>(1)</sup> N. 12 bolts for ABS certified version only. N. 8 bolts for other versions.

<sup>(2)</sup> Catalogue dimensions only for reference, see dimensional drawing for detailed information

Brevini® Hydraulic Axial Piston Motor for Lifting of Personnel Winches

	Motor Type	Displacement	L
Fixed Displacement	SH11C090	86.23 cm <sup>3</sup> /rev [5.26 in <sup>3</sup> /rev]	286 mm [11.30 in]
Fixed Displacement	SH11C125	124.8 cm <sup>3</sup> /rev [7.613 in <sup>3</sup> /rev]	336 mm [13.20 in]
Variable Displacement	SH9V115	115.7 cm <sup>3</sup> /rev [7.05 in <sup>3</sup> /rev]	432 mm [17.00 in]
With NO Motor	Universal Input Flange 00	-	4.5 mm [0.177 in]

Lifting of Personnel Winch <sup>(3)</sup>

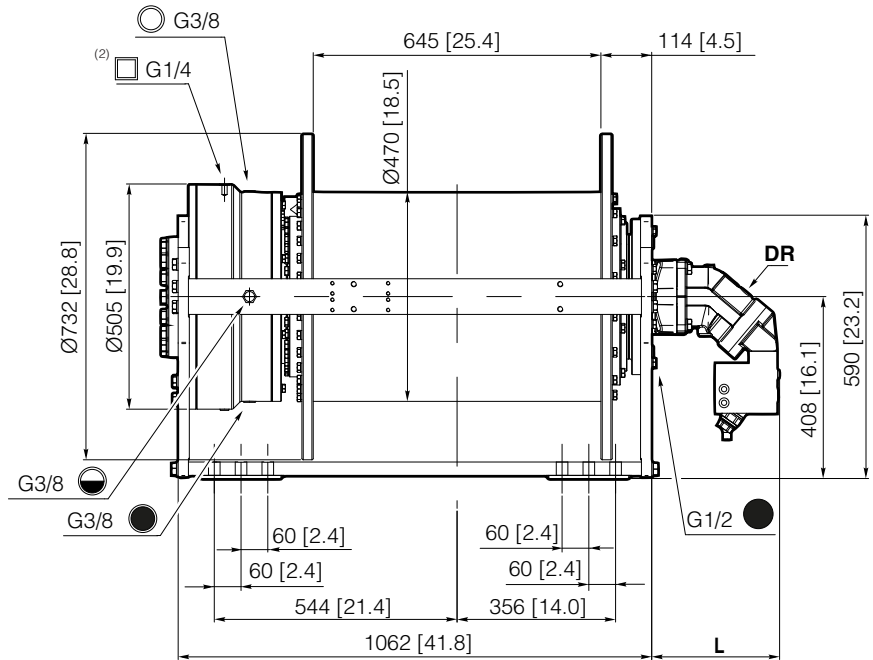
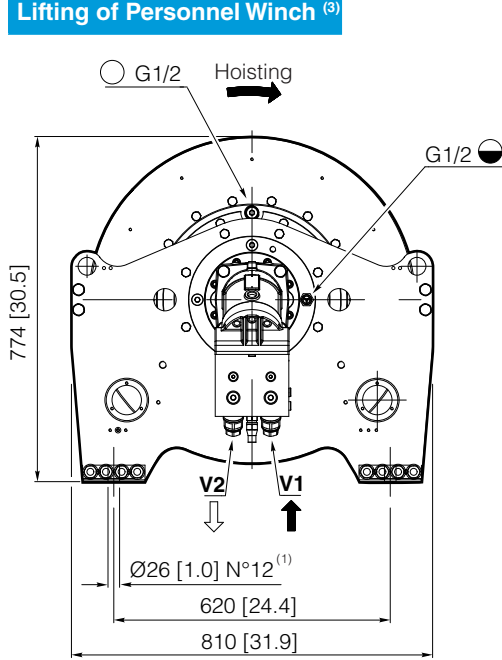

<sup>(1)</sup> N. 12 bolts for ABS certified version only. N. 8 bolts for other versions.

<sup>(2)</sup> Lifting of personnel brake release pressure (Release / Max) 23.5/300 bar [341/4355 psi]

<sup>(3)</sup> Catalogue dimensions only for reference, see dimensional drawing for detailed information

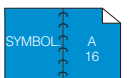

### Motor Drum Winch

Available on request .

- with or without motor
- smooth or grooved drum
- customized drum length
- different rope diameter

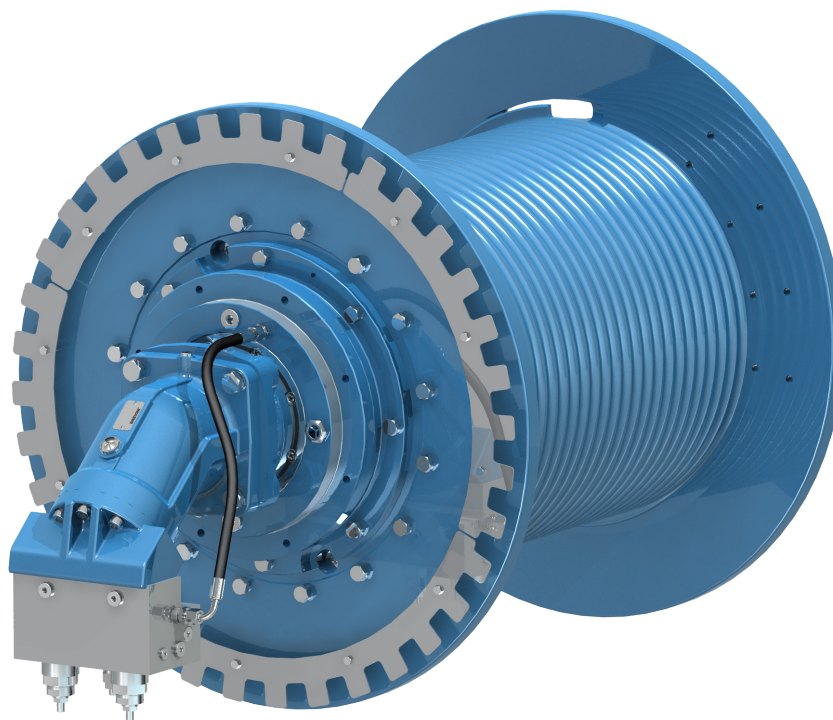

### Our Standard Configurations

Hydraulic Motor Fixed Displacement	SH11C090	86.23 cm <sup>3</sup> /rev	5.26 [in <sup>3</sup> /rev]
	SH11C125	124.8 cm <sup>3</sup> /rev	4.747 [in <sup>3</sup> /rev]
Hydraulic Motor Variable Displacement	SH9V115	115.7 [cm <sup>3</sup> /rev]	7.05 [in <sup>3</sup> /rev]
Ratio		50.8	
		83.2	
Drum	standard	Smooth Drum Special Grooved Drum <sup>(1)</sup>	
Rope		Ø 20 [mm] Ø 22 [mm] Ø 24 [mm]	Ø 0.78 [in] Ø 0.86 [in] Ø 0.94 [in]

<sup>(1)</sup> Left hand grooving as Standard only with rope diameter Ø 22 mm [0.86 in]. Right handal grooving on request. Other rope diameter available on request.



## International System of Units: SI

BWE105-SD22..-01-83.2-APF090

Working layer		1	2	3	4	5	6	
								Storage length
Line pull	[kg]	10500	9750	9110	8540	8040	-	
Rope speed	[m/min]	30	32	35	37	39	-	
Rope length	[m]	44	89	140	192	250	309	
Brevini® Motor	SH11C090	Advised rope diameter				22	[mm]	
Starting lifting pressure	315 [bar]	Oil fill / drain plug				G1/2	T	
Operating pressure	265 [bar]	Lifting / Lowering port				G1	V1 / V2	
Operating oil flow at the motor	150 [l/min]	Motor drain port				G1/2	DR	
Minimum oil flow at the motor	6.0 [l/min]	Static braking torque <sup>(1)</sup>				1172	[Nm]	
Gear ratio	83.2 [i]	Brake release pressure (Release/Max)				26 / 350	[bar]	
Winch mechanisms classification in agreement with F.E.M. (1.001) (Third edition revised on 01.10.1998)						M5 (T5-L2)	n <sub>2</sub> =15 [rpm]	

	Weight [kg]		Oil [l]	
	Cargo	LoP	Cargo	LoP
<b>BWE105-SD22..-01-83,2-APF090-LP</b>	899	1132	29.5	34

## United States Customary Units: USC

BWE105-SD22..-01-83.2-APF090

Working layer		1	2	3	4	5	6	
								Storage length
Line pull	[lbf]	23100	21510	20080	18840	17730	-	
Rope speed	[fpm]	99	107	114	122	130	-	
Rope length	[ft]	144	294	461	632	821	1014	
Brevini® Motor	SH11C090	Advised rope diameter				0.86	[in]	
Starting lifting pressure	4595 [psi]	Oil fill / drain plug				G1/2	T	
Operating pressure	3835 [psi]	Lifting / Lowering port				G1	V1 / V2	
Operating oil flow at the motor	40 [gpm]	Motor drain port				G1/2	DR	
Minimum oil flow at the motor	1.58 [gpm]	Static braking torque <sup>(1)</sup>				864	[ft-lbf]	
Gear ratio	83.2 [i]	Brake release pressure (Release/Max)				380 / 5080	[psi]	
Winch mechanisms classification in agreement with F.E.M. (1.001) (Third edition revised on 01.10.1998)						M5 (T5-L2)	n <sub>2</sub> =15 [rpm]	

	Weight [lbs]		Oil [gal]	
	Cargo	LoP	Cargo	LoP
<b>BWE105-SD22..-01-83,2-APF090-LP</b>	1982	2496	7.79	8.98

**Note:**

- For safety reasons always keep at least 3 wraps of rope wrapped on the drum.
- Technical features may change with no previous notice from the manufacturer.
- The MBL of the Rope must be verified according to the requested Safety Factors.
- All data shown in this page are ONLY FOR INFORMATION. The actual data will be issued according to Customer application and Duty Cycle.

<sup>(1)</sup> Static braking torque does not affect the winch maximum static line pull which must be considered 125% of the nominal line pull at first layer.

## Line pull for Certified Winch Version: SI

Rope Diameter	Line Pull (according to DNVGL) [kg]				Line Pull (according to ABS) [kg]			
	Cargo Winch		Lifting of Personnell Winch		Cargo Winch		Lifting of Personnell Winch	
	Last Layer	First Layer	Last Layer	First Layer	Last Layer	First Layer	Last Layer	First Layer
Ø 20 [mm]	5630 (5) <sup>(1)</sup>	7200	2190 (5) <sup>(1)</sup>	2800	5630 (5) <sup>(1)</sup>	7200	2659 (5) <sup>(1)</sup>	3400
Ø 22 [mm]	6834 (4) <sup>(1)</sup>	8400	2278 (4) <sup>(1)</sup>	2800	6834 (4) <sup>(1)</sup>	8400	2766 (4) <sup>(1)</sup>	3400
Ø 24 [mm]	7204 (3) <sup>(1)</sup>	8400	2402 (3) <sup>(1)</sup>	2800	7204 (3) <sup>(1)</sup>	8400	2916 (3) <sup>(1)</sup>	3400

## Line pull for Certified Winch Version: USC

Rope Diameter	Line Pull (according to DNVGL) [lbf]				Line Pull (according to ABS) [lbf]			
	Cargo Winch		Lifting of Personnell Winch		Cargo Winch		Lifting of Personnell Winch	
	Last Layer	First Layer	Last Layer	First Layer	Last Layer	First Layer	Last Layer	First Layer
Ø 0.78 [in]	12412 (5) <sup>(1)</sup>	15873	4828 (5) <sup>(1)</sup>	6172	12412 (5) <sup>(1)</sup>	15873	5862 (5) <sup>(1)</sup>	7495
Ø 0.86 [in]	15066 (4) <sup>(1)</sup>	18518	5022 (4) <sup>(1)</sup>	6172	15066 (4) <sup>(1)</sup>	18518	6097 (4) <sup>(1)</sup>	7495
Ø 0.94 [in]	15882 (3) <sup>(1)</sup>	18518	5295 (3) <sup>(1)</sup>	6172	15882 (3) <sup>(1)</sup>	18518	6428 (3) <sup>(1)</sup>	7495

The line pull listed above are just for reference, for this application is strongly recommended to fill up the Winch Application Data Form available at the end of this catalogue and consult the Dana area contact person for final selection and validation.

## Other Ropes available

Working layer			1	2	3	4	5	6
Rope Diameter Ø 20 [mm]	Rope length	[m]	48	98	153	209	271	334
Rope Diameter Ø 24 [mm]	Rope length	[m]	40	82	130	178	232	-

## Other Ropes available

Working layer			1	2	3	4	5	6
Rope Diameter Ø 0,78 [in]	Rope length	[ft]	158	322	502	687	890	1097
Rope Diameter Ø 0,94 [in]	Rope length	[ft]	133	271	426	586	763	-

Last indicated Layer is intended only as Storage

<sup>(1)</sup> Last working layer

Axial Piston Motor Fixed Displacement

Maximum Line pull at first layer

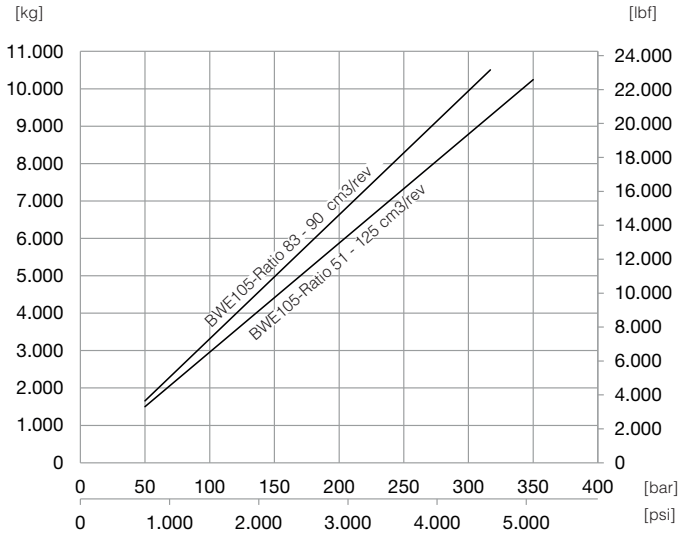

Maximum Speed at first layer

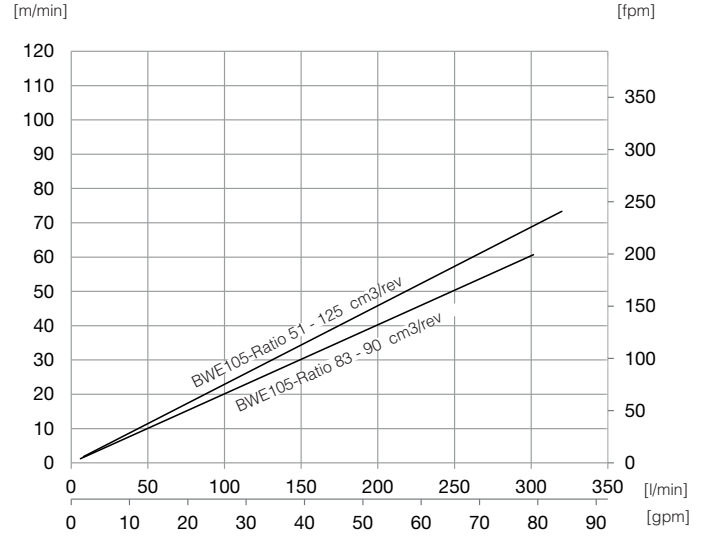

Axial Piston Motor Variable Displacement

Maximum Line pull at first layer

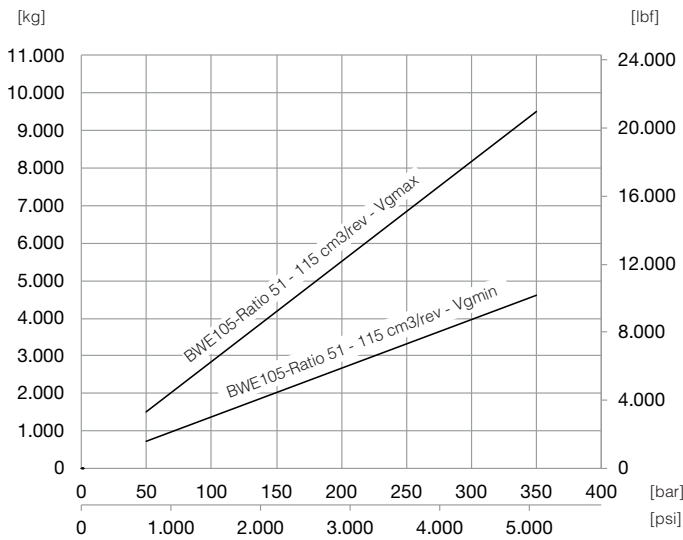

$V_{g_{max}} = 115 \text{ cm}^3/\text{rev}$  [7.05 in<sup>3</sup>/rev]  
 $V_{g_{min}} = 56 \text{ cm}^3/\text{rev}$  [3.416 in<sup>3</sup>/rev]

Maximum Speed at first layer

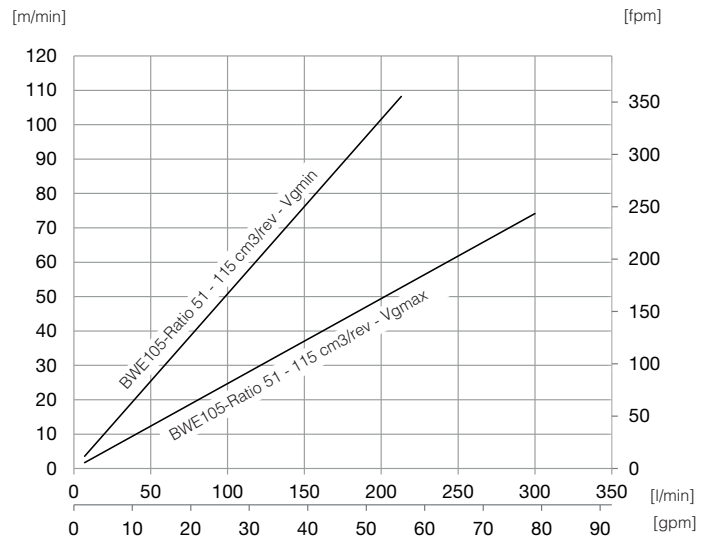

$V_{g_{max}} = 115 \text{ cm}^3/\text{rev}$  [7.05 in<sup>3</sup>/rev] - Max 300 l/min [80 gpm] allowed  
 $V_{g_{min}} = 56 \text{ cm}^3/\text{rev}$  [3.416 in<sup>3</sup>/rev] - Max 212 l/min [56 gpm] allowed

Note:

- All data shown in this page are ONLY FOR INFORMATION. The actual data will be issued according to Customer application and Duty Cycle.



**BREVINI<sup>®</sup>**

*Motion Systems*

**Line Pull at first Layer up to:**  
**12.500 [kg]**  
**27.500 [lbf]**

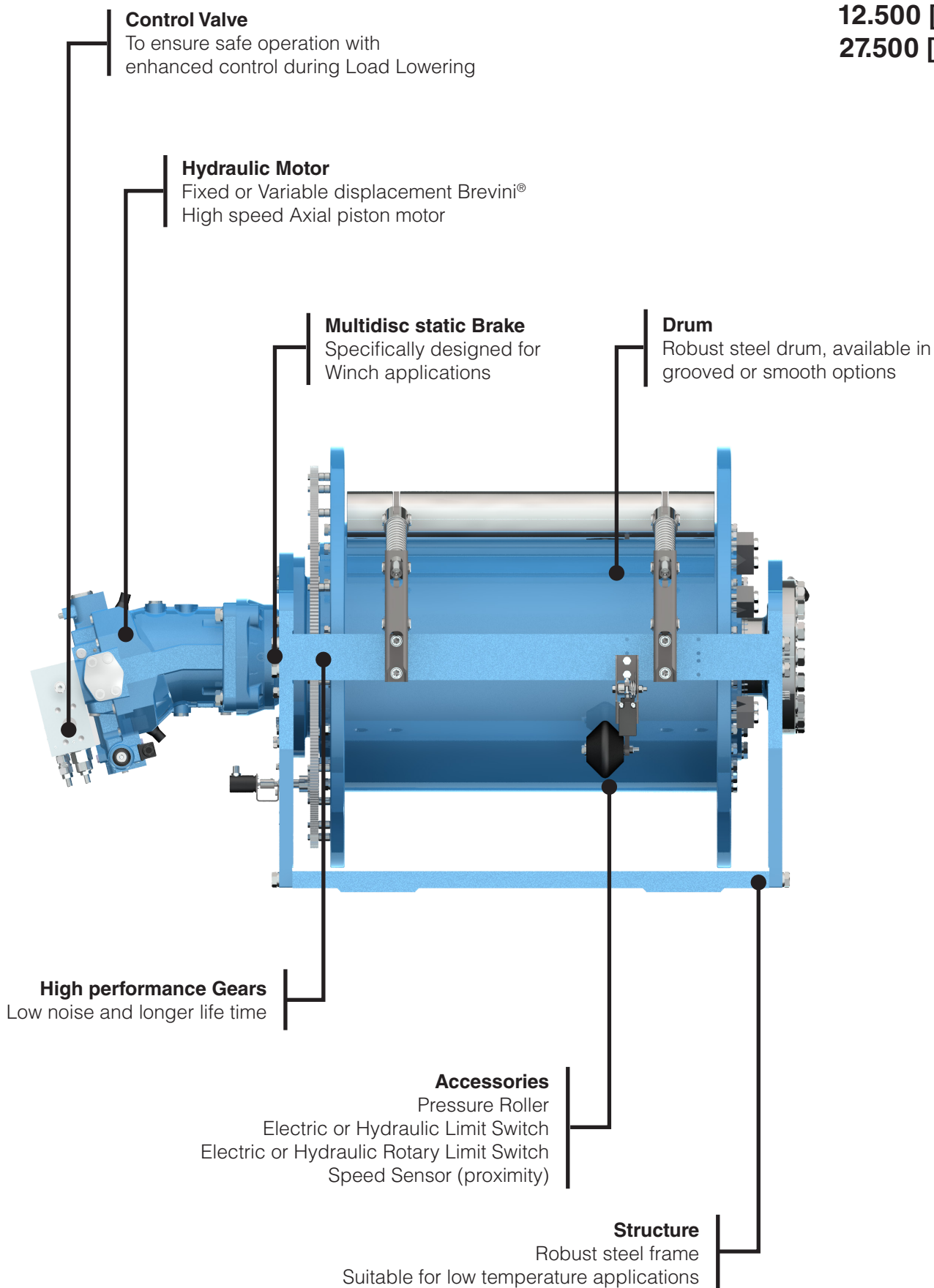

Brevini® Hydraulic Axial Piston Motor

	Motor Type	Displacement	L
Fixed Displacement	SH11C125	124.8 cm <sup>3</sup> /rev [7.613 in <sup>3</sup> /rev]	336 mm [13.2 in]
Fixed Displacement	SH11C160	163.9 cm <sup>3</sup> /rev [9.998 in <sup>3</sup> /rev]	400 mm [15.8 in]
Variable Displacement	SH9V165	166.2 cm <sup>3</sup> /rev [10.13 in <sup>3</sup> /rev]	489 mm [19.2 in]
With NO Motor	Universal Input Flange 00	-	4.5 mm [0.177 in]

Winch <sup>(2)</sup>

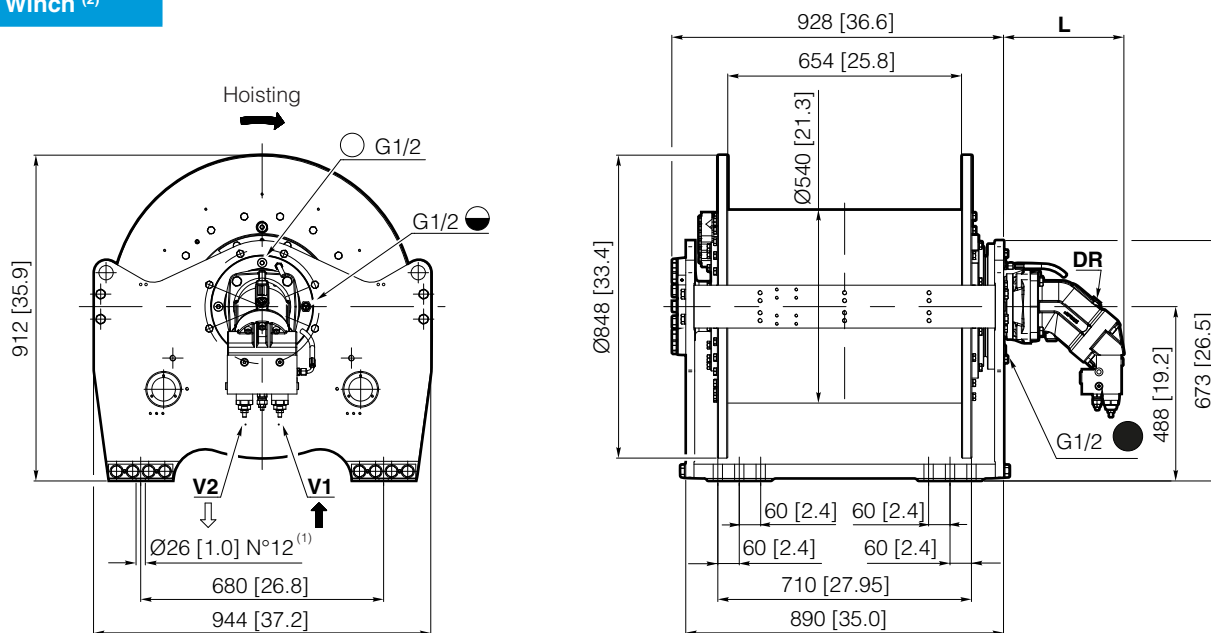

<sup>(1)</sup> N. 12 bolts for ABS certified version only. N. 8 bolts for other versions.

<sup>(2)</sup> Catalogue dimensions only for reference, see dimensional drawing for detailed information

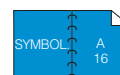

Brevini® Hydraulic Axial Piston Motor for Lifting of Personnel Winches

	Motor Type	Displacement	L
Fixed Displacement	SH11C125	124.8 cm <sup>3</sup> /rev [7.613 in <sup>3</sup> /rev]	336 mm [13.2 in]
Fixed Displacement	SH11C160	163.9 cm <sup>3</sup> /rev [9.998 in <sup>3</sup> /rev]	400 mm [15.8 in]
Variable Displacement	SH9V165	166.2 cm <sup>3</sup> /rev [10.13 in <sup>3</sup> /rev]	489 mm [19.2 in]
With NO Motor	Universal Input Flange 00	-	4.5 mm [0.177 in]

Lifting of Personnel Winch <sup>(3)</sup>

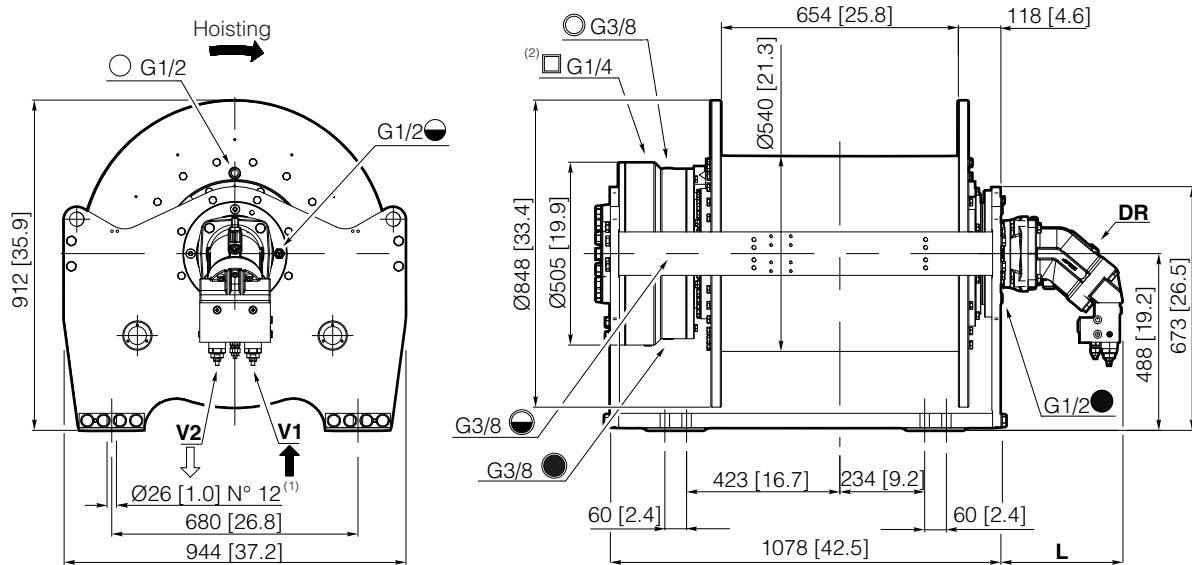

<sup>(1)</sup> N. 12 bolts for ABS certified version only. N. 8 bolts for other versions.

<sup>(2)</sup> Lifting of personnel brake release pressure (Release / Max) 33/300 bar [479/4355 psi]

<sup>(3)</sup> Catalogue dimensions only for reference, see dimensional drawing for detailed information

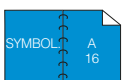

### Motor Drum Winch

Available on request .

- with or without motor
- smooth or grooved drum
- customized drum length
- different rope diameter

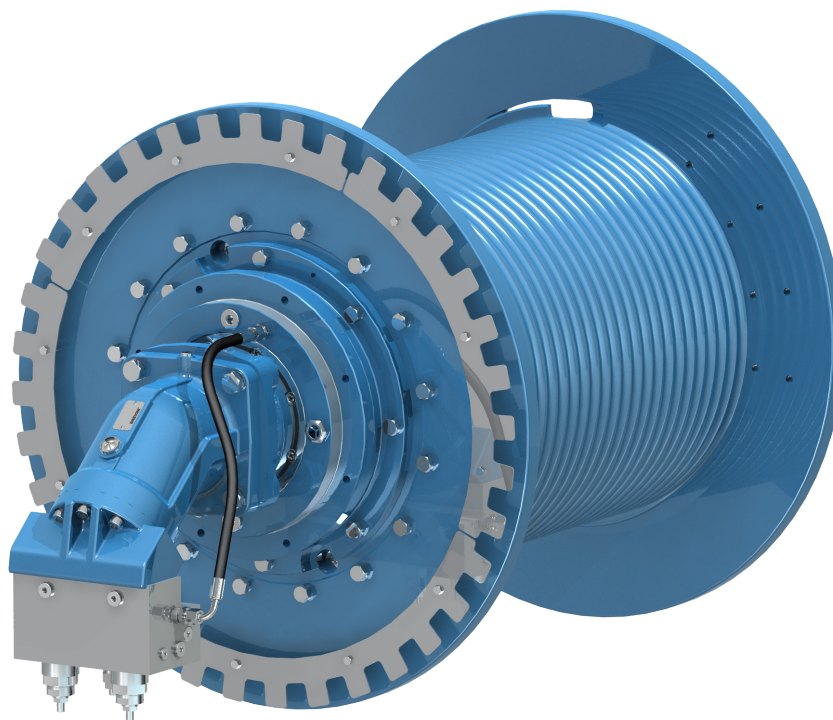

### Our Standard Configurations

Hydraulic Motor Fixed Displacement	SH11C125	124.8 cm <sup>3</sup> /rev	7.613 [in <sup>3</sup> /rev]
	SH11C160	163.9 cm <sup>3</sup> /rev	9.998 [in <sup>3</sup> /rev]
Hydraulic Motor Variable Displacement	SH9V165	166.2 [cm <sup>3</sup> /rev]	10.13 [in <sup>3</sup> /rev]
Ratio		50.8	
		83.2	
Drum	standard	Smooth Drum Special Grooved Drum <sup>(1)</sup>	
Rope		Ø 24 [mm] Ø 26 [mm] Ø 28 [mm]	Ø 0.94 [in] Ø 1.02 [in] Ø 1.10 [in]

<sup>(1)</sup> Left hand grooving as Standard only with rope diameter Ø 26 mm [1.02 in]. Right handal grooving on request. Other rope diameter available on request.



## International System of Units: SI

BWE125-SD26..-01-83.2-APF125

Working layer		1	2	3	4	5	6
		<b>Storage length</b>					
Line pull	[kg]	12500	11590	10810	10120	9510	-
Rope speed	[m/min]	24	26	27	29	31	-
Rope length	[m]	43	88	139	190	247	306
Brevini® Motor	SH11C125	Advised rope diameter				26	[mm]
Starting lifting pressure	300 [bar]	Oil fill / drain plug				G1/2	T
Operating pressure	250 [bar]	Lifting / Lowering port				G1	V1 / V2
Operating oil flow at the motor	150 [l/min]	Motor drain port				G1/2	DR
Minimum oil flow at the motor	8.0 [l/min]	Static braking torque <sup>(1)</sup>				1172	[Nm]
Gear ratio	83.2 [i]	Brake release pressure (Release/Max)				26 / 350	[bar]
Winch mechanisms classification in agreement with F.E.M. (1.001) (Third edition revised on 01.10.1998)						M5 (T5-L2)	n <sub>2</sub> =15 [rpm]

	Weight [kg]		Oil [l]	
	Cargo	LoP	Cargo	LoP
<b>BWE125-SD26..-01-83,2-APF125-LP</b>	1162	1408	45,5	49,5

## United States Customary Units: USC

BWE125-SD26..-01-83.2-APF125

Working layer		1	2	3	4	5	6
		<b>Storage length</b>					
Line pull	[lbf]	27500	25560	23830	22310	20980	-
Rope speed	[fpm]	79	85	91	97	104	-
Rope length	[ft]	142	290	456	625	813	1004
Brevini® Motor	SH11C125	Advised rope diameter				1.02	[in]
Starting lifting pressure	4350 [psi]	Oil fill / drain plug				G1/2	T
Operating pressure	3630 [psi]	Lifting / Lowering port				G1	V1 / V2
Operating oil flow at the motor	40 [gpm]	Motor drain port				G1/2	DR
Minimum oil flow at the motor	2.11 [gpm]	Static braking torque <sup>(1)</sup>				864	[ft·lbf]
Gear ratio	83.2 [i]	Brake release pressure (Release/Max)				380 / 5080	[psi]
Winch mechanisms classification in agreement with F.E.M. (1.001) (Third edition revised on 01.10.1998)						M5 (T5-L2)	n <sub>2</sub> =15 [rpm]

	Weight [lbs]		Oil [gal]	
	Cargo	LoP	Cargo	LoP
<b>BWE125-SD26..-01-83,2-APF125-LP</b>	2562	3104	12,02	13,08

**Note:**

- For safety reasons always keep at least 3 wraps of rope wrapped on the drum.
- Technical features may change with no previous notice from the manufacturer.
- The MBL of the Rope must be verified according to the requested Safety Factors.
- All data shown in this page are ONLY FOR INFORMATION. The actual data will be issued according to Customer application and Duty Cycle.

<sup>(1)</sup> Static braking torque does not affect the winch maximum static line pull which must be considered 125% of the nominal line pull at first layer.

## Line pull for Certified Winch Version: SI

Rope Diameter	Line Pull (according to DNVGL) [kg]				Line Pull (according to ABS) [kg]			
	Cargo Winch		Lifting of Personnell Winch		Cargo Winch		Lifting of Personnell Winch	
	Last Layer	First Layer	Last Layer	First Layer	Last Layer	First Layer	Last Layer	First Layer
Ø 24 [mm]	7127 (5) <sup>(1)</sup>	9200	2713 (5) <sup>(1)</sup>	3500	7127 (5) <sup>(1)</sup>	9200	3254 (5) <sup>(1)</sup>	4200
Ø 26 [mm]	8500 (4) <sup>(1)</sup>	10501	2834 (4) <sup>(1)</sup>	3500	8500 (4) <sup>(1)</sup>	10501	3400 (4) <sup>(1)</sup>	4200
Ø 28 [mm]	8987 (3) <sup>(1)</sup>	10501	2996 (3) <sup>(1)</sup>	3500	8987 (3) <sup>(1)</sup>	10501	3595 (3) <sup>(1)</sup>	4200

## Line pull for Certified Winch Version: USC

Rope Diameter	Line Pull (according to DNVGL) [lbf]				Line Pull (according to ABS) [lbf]			
	Cargo Winch		Lifting of Personnell Winch		Cargo Winch		Lifting of Personnell Winch	
	Last Layer	First Layer	Last Layer	First Layer	Last Layer	First Layer	Last Layer	First Layer
Ø 0.94 [in]	15712 (5) <sup>(1)</sup>	20282	5981 (5) <sup>(1)</sup>	7716	15712 (5) <sup>(1)</sup>	20282	7173 (5) <sup>(1)</sup>	9259
Ø 1.02 [in]	18739 (4) <sup>(1)</sup>	23150	6247 (4) <sup>(1)</sup>	7716	18739 (4) <sup>(1)</sup>	23150	7495 (4) <sup>(1)</sup>	9259
Ø 1.10 [in]	19812 (3) <sup>(1)</sup>	23150	6605 (3) <sup>(1)</sup>	7716	19812 (3) <sup>(1)</sup>	23150	7925 (3) <sup>(1)</sup>	9259

The line pull listed above are just for reference, for this application is strongly recommended to fill up the Winch Application Data Form available at the end of this catalogue and consult the Dana area contact person for final selection and validation.

## Other Ropes available

Working layer			1	2	3	4	5	6
Rope Diameter Ø 24 [mm]	Rope length	[m]	47	95	149	204	265	326
Rope Diameter Ø 28 [mm]	Rope length	[m]	40	82	130	178	232	-

## Other Ropes available

Working layer			1	2	3	4	5	6
Rope Diameter Ø 0,94 [in]	Rope length	[ft]	154	313	490	671	870	1072
Rope Diameter Ø 1.10 [in]	Rope length	[ft]	133	271	426	586	764	-

Last indicated Layer is intended only as Storage

<sup>(1)</sup> Last working layer

Axial Piston Motor Fixed Displacement

Maximum Line pull at first layer

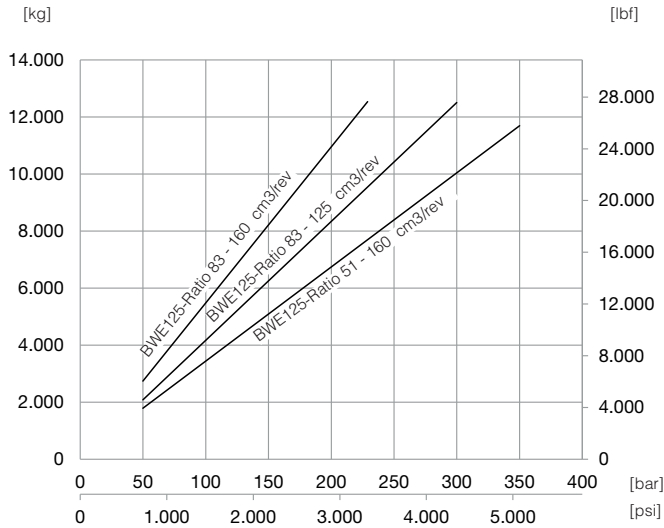

Maximum Speed at first layer

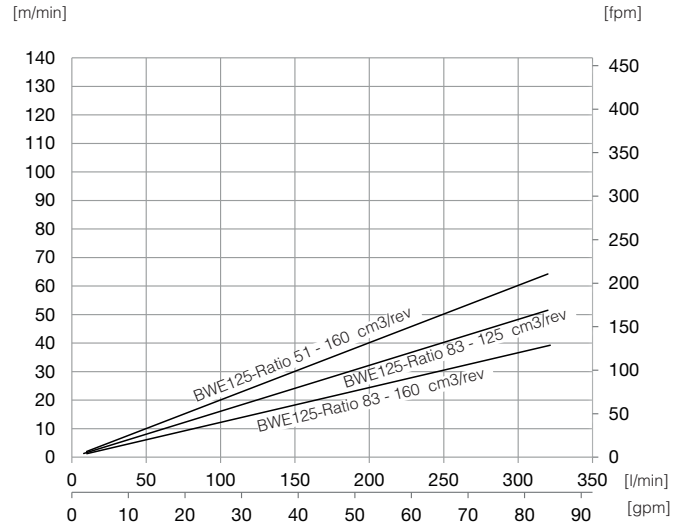

Axial Piston Motor Variable Displacement

Maximum Line pull at first layer

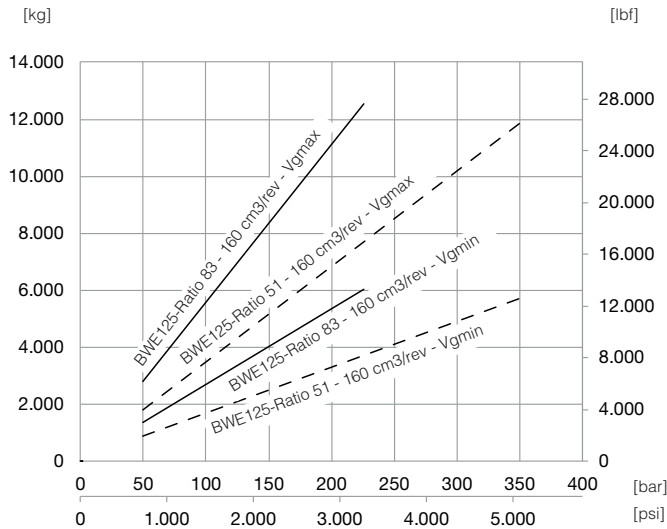

$V_{g_{max}} = 166.2 \text{ cm}^3/\text{rev}$  [10.13 in<sup>3</sup>/rev]  
 $V_{g_{min}} = 80 \text{ cm}^3/\text{rev}$  [4.88 in<sup>3</sup>/rev]

Maximum Speed at first layer

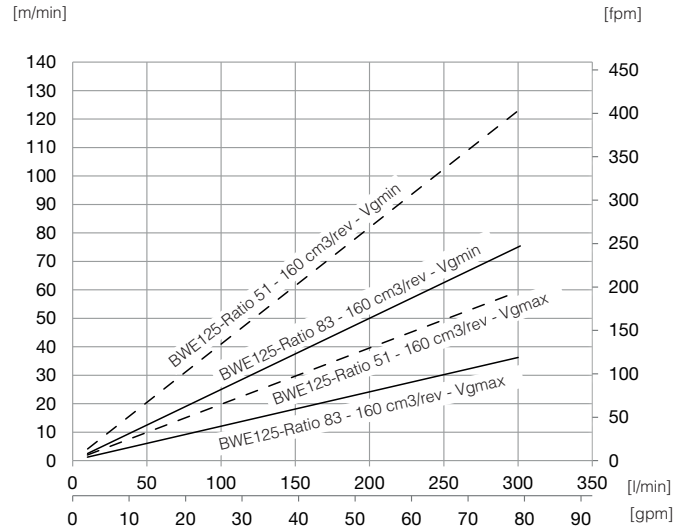

$V_{g_{max}} = 166.2 \text{ cm}^3/\text{rev}$  [10.13 in<sup>3</sup>/rev] - Max 300 l/min [79 gpm] allowed  
 $V_{g_{min}} = 80 \text{ cm}^3/\text{rev}$  [4.88 in<sup>3</sup>/rev] - Max 300 l/min [79 gpm] allowed

**Note:**

- All data shown in this page are ONLY FOR INFORMATION. The actual data will be issued according to Customer application and Duty Cycle.



**BREVINI<sup>®</sup>**

*Motion Systems*

**Line Pull at first Layer up to:**  
**16.000 [kg]**  
**35.300 [lbf]**

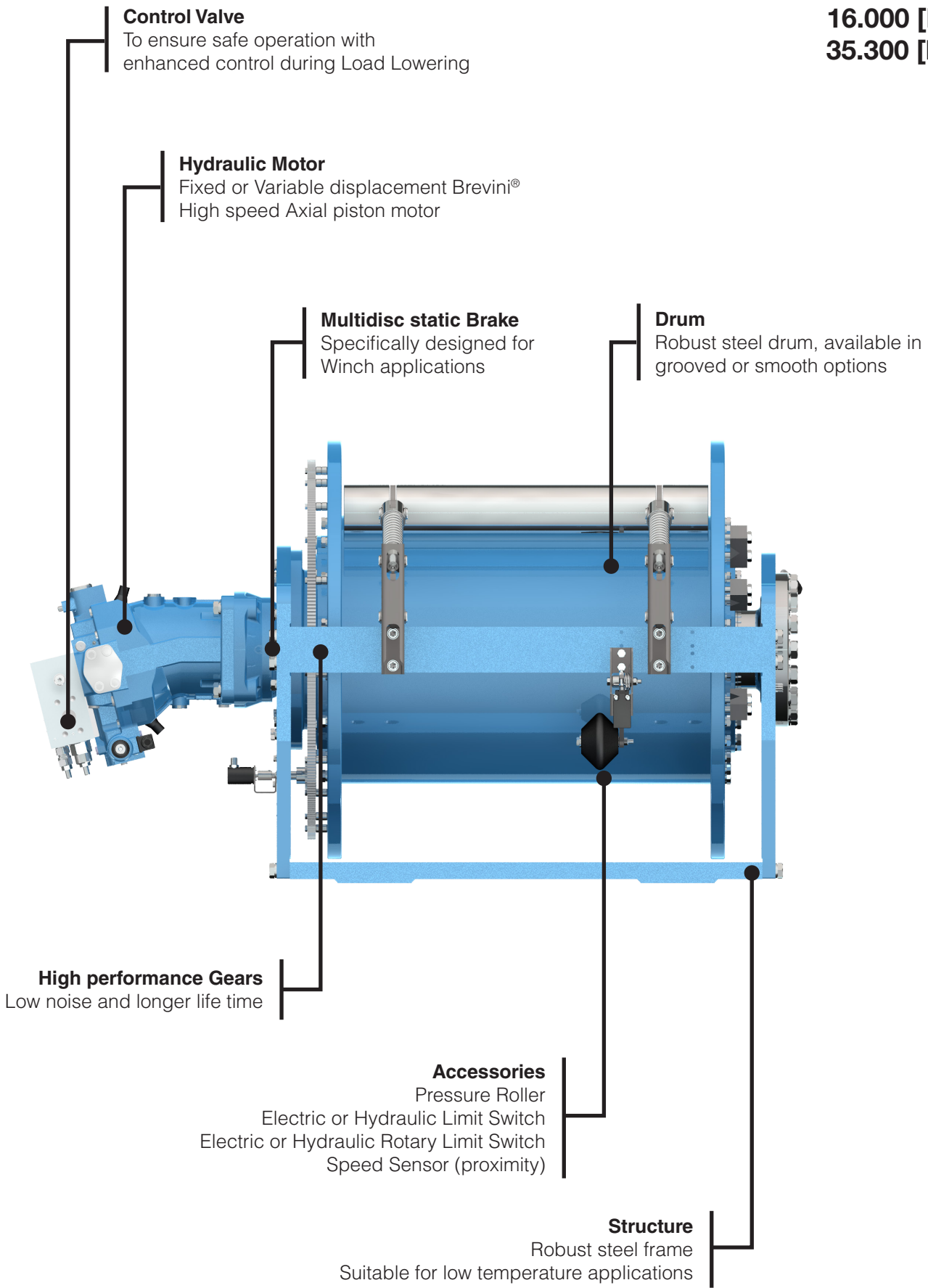

Brevini® Hydraulic Axial Piston Motor

	Motor Type	Displacement	L
Fixed Displacement	SH11C125	124.8 cm <sup>3</sup> /rev [7.613 in <sup>3</sup> /rev]	336 mm [13.2 in]
Fixed Displacement	SH11C160	163.9 cm <sup>3</sup> /rev [9.998 in <sup>3</sup> /rev]	400 mm [15.8 in]
Variable Displacement	SH9V165	166.2 cm <sup>3</sup> /rev [10.13 in <sup>3</sup> /rev]	489 mm [19.2 in]
With NO Motor	Universal Input Flange 00	-	4.5 mm [0.177 in]

Winch <sup>(2)</sup>

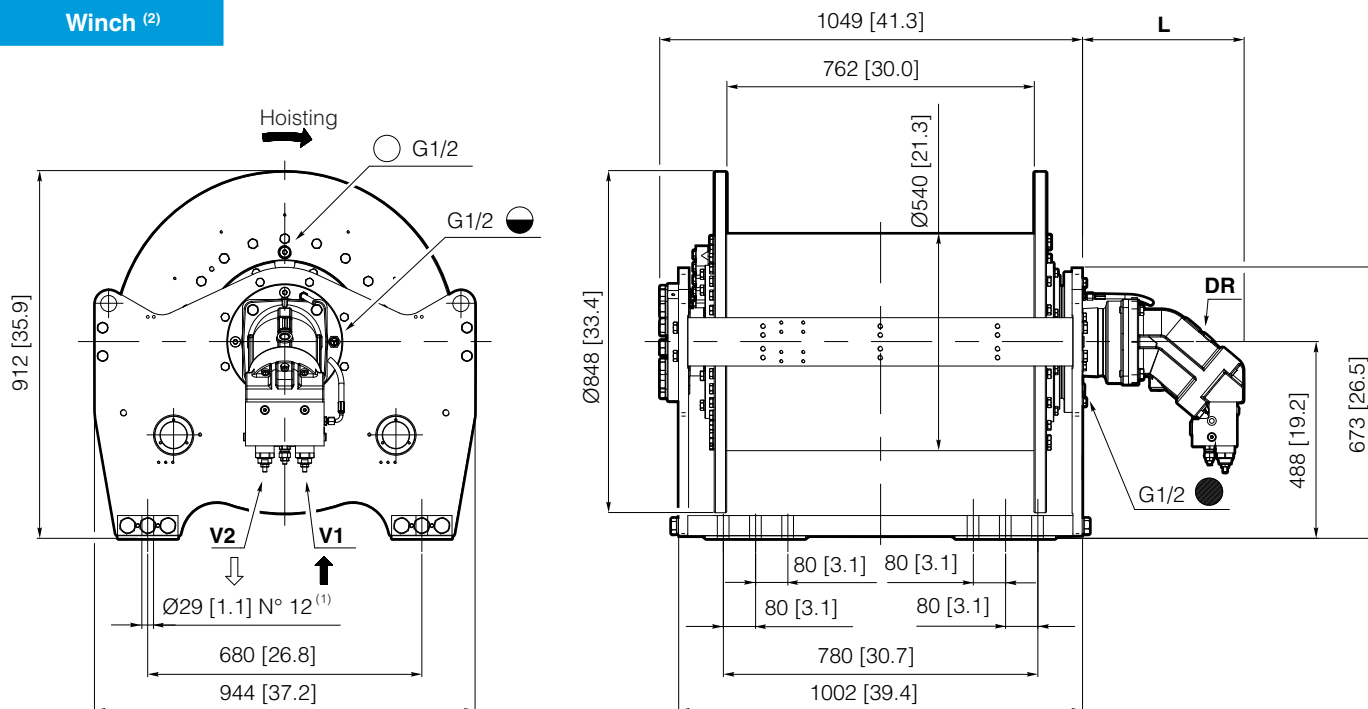

<sup>(1)</sup> N. 12 bolts for ABS certified version only. N. 8 bolts for other versions.

<sup>(2)</sup> Catalogue dimensions only for reference, see dimensional drawing for detailed information

Brevini® Hydraulic Axial Piston Motor for Lifting of Personnel Winches

	Motor Type	Displacement	L
Fixed Displacement	SH11C125	124.8 cm <sup>3</sup> /rev [7.613 in <sup>3</sup> /rev]	336 mm [13.2 in]
Fixed Displacement	SH11C160	163.9 cm <sup>3</sup> /rev [9.998 in <sup>3</sup> /rev]	400 mm [15.8 in]
Variable Displacement	SH9V165	166.2 cm <sup>3</sup> /rev [10.13 in <sup>3</sup> /rev]	489 mm [19.2 in]
With NO Motor	Universal Input Flange 00	-	4.5 mm [0.177 in]

Lifting of Personnel Winch <sup>(3)</sup>

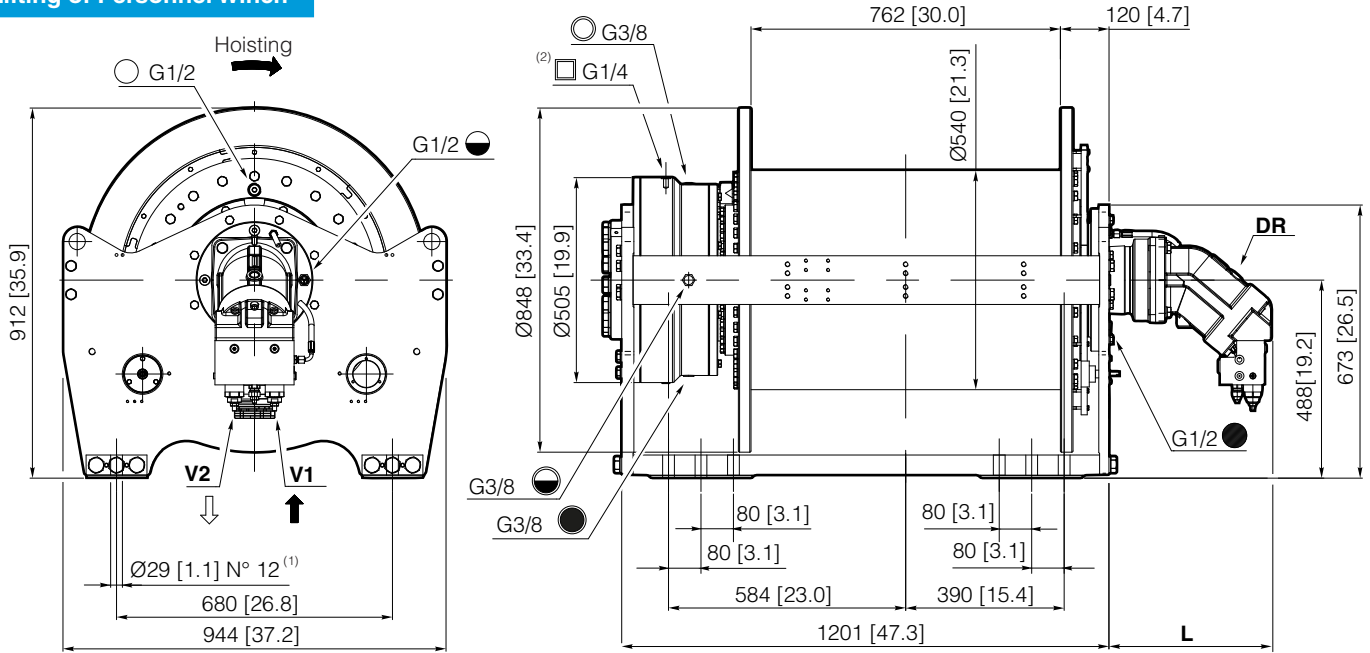

<sup>(1)</sup> N. 12 bolts for ABS certified version only. N. 8 bolts for other versions.

<sup>(2)</sup> Lifting of personnel brake release pressure (Release / Max) 40/300 bar [580/4355 psi]

<sup>(3)</sup> Catalogue dimensions only for reference, see dimensional drawing for detailed information

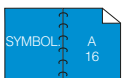

### Motor Drum Winch

Available on request .

- with or without motor
- smooth or grooved drum
- customized drum length
- different rope diameter

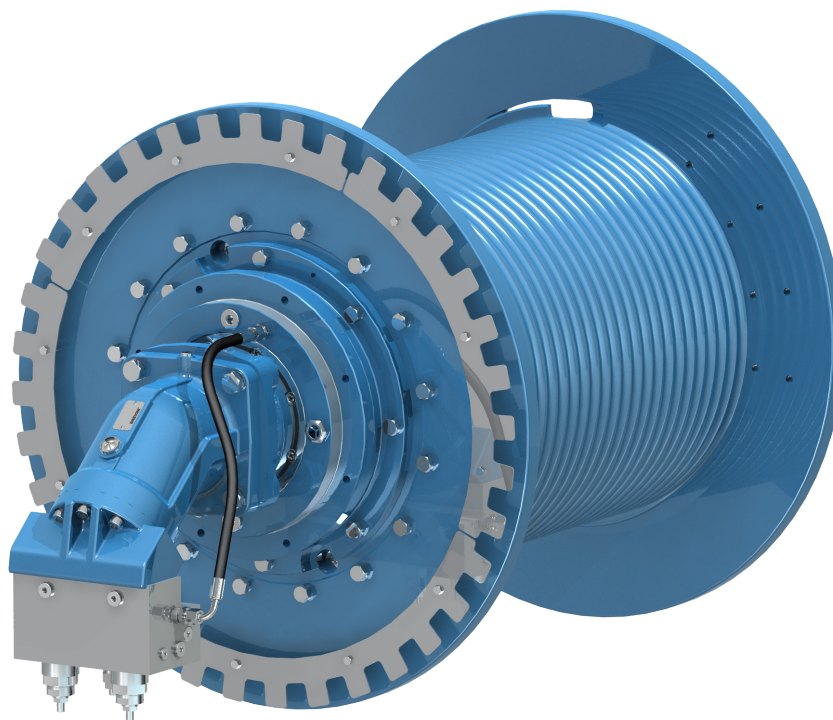

### Our Standard Configurations

Hydraulic Motor Fixed Displacement	SH11C125	124.8 cm <sup>3</sup> /rev	7.613 [in <sup>3</sup> /rev]
	SH11C160	163.9 cm <sup>3</sup> /rev	9.998 [in <sup>3</sup> /rev]
Hydraulic Motor Variable Displacement	SH9V165	166.2 [cm <sup>3</sup> /rev]	10.13 [in <sup>3</sup> /rev]
Ratio		61.5	
		92.6	
Drum	standard	Smooth Drum Special Grooved Drum <sup>(1)</sup>	
Rope		Ø 24 [mm] Ø 26 [mm] Ø 28 [mm]	Ø 0.94 [in] Ø 1.02 [in] Ø 1.10 [in]

<sup>(1)</sup> Left hand grooving as Standard only with rope diameter Ø 26 mm [1.02 in]. Right handal grooving on request. Other rope diameter available on request.



International System of Units: SI

BWE160-SD26..-01-92.6-APF125

Working layer		1	2	3	4	5	6	
		<b>Storage length</b>						
Line pull	[kg]	16000	14880	13870	12990	12210	-	
Rope speed	[m/min]	21	23	25	26	28	-	
Rope length	[m]	50	103	162	222	289	357	
Brevini® Motor	SH11C125	Advised rope diameter					26	[mm]
Starting lifting pressure	345 [bar]	Oil fill / drain plug					G1/2	T
Operating pressure	290 [bar]	Lifting / Lowering port					G1	V1 / V2
Operating oil flow at the motor	150 [l/min]	Motor drain port					G1/2	DR
Minimum oil flow at the motor	8.0 [l/min]	Static braking torque <sup>(1)</sup>					1172	[Nm]
Gear ratio	92.6 [i]	Brake release pressure (Release/Max)					26 / 350	[bar]
Winch mechanisms classification in agreement with F.E.M. (1.001) (Third edition revised on 01.10.1998)						M5 (T5-L2)	n <sub>2</sub> =15 [rpm]	

	Weight [kg]		Oil [l]	
	Cargo	LoP	Cargo	LoP
<b>BWE160-SD26..-01-92,6-APF125-LP</b>	1470	1770	42	44,6

United States Customary Units: USC

BWE160-SD26..-01-92,6-APF125

Working layer		1	2	3	4	5	6	
		<b>Storage length</b>						
Line pull	[lbf]	35300	32810	30590	28640	26930	-	
Rope speed	[fpm]	71	76	82	87	93	-	
Rope length	[ft]	166	339	531	729	948	1171	
Brevini® Motor	SH11C125	Advised rope diameter					1.02	[in]
Starting lifting pressure	5015 [psi]	Oil fill / drain plug					G1/2	T
Operating pressure	4185 [psi]	Lifting / Lowering port					G1	V1 / V2
Operating oil flow at the motor	40 [gpm]	Motor drain port					G1/2	DR
Minimum oil flow at the motor	2.11 [gpm]	Static braking torque <sup>(1)</sup>					864	[ft·lbf]
Gear ratio	92.6 [i]	Brake release pressure (Release/Max)					380 / 5080	[psi]
Winch mechanisms classification in agreement with F.E.M. (1.001) (Third edition revised on 01.10.1998)						M5 (T5-L2)	n <sub>2</sub> =15 [rpm]	

	Weight [lbs]		Oil [gal]	
	Cargo	LoP	Cargo	LoP
<b>BWE160-SD26..-01-92,6-APF125-LP</b>	3241	3902	11,10	11,78

**Note:**

- For safety reasons always keep at least 3 wraps of rope wrapped on the drum.
- Technical features may change with no previous notice from the manufacturer.
- The MBL of the Rope must be verified according to the requested Safety Factors.
- All data shown in this page are ONLY FOR INFORMATION. The actual data will be issued according to Customer application and Duty Cycle.

<sup>(1)</sup> Static braking torque does not affect the winch maximum static line pull which must be considered 125% of the nominal line pull at first layer.

## Line pull for Certified Winch Version: SI

Rope Diameter	Line Pull (according to DNVGL) [kg]				Line Pull (according to ABS) [kg]			
	Cargo Winch		Lifting of Personnell Winch		Cargo Winch		Lifting of Personnell Winch	
	Last Layer	First Layer	Last Layer	First Layer	Last Layer	First Layer	Last Layer	First Layer
Ø 24 [mm]	8522 (5) <sup>(1)</sup>	11000	3331 (5) <sup>(1)</sup>	4300	8522 (5) <sup>(1)</sup>	11000	4029 (5) <sup>(1)</sup>	5200
Ø 26 [mm]	10361 (4) <sup>(1)</sup>	12800	3481 (4) <sup>(1)</sup>	4300	10361 (4) <sup>(1)</sup>	12800	4209 (4) <sup>(1)</sup>	5200
Ø 28 [mm]	10955 (3) <sup>(1)</sup>	12800	3681 (3) <sup>(1)</sup>	4300	10955 (3) <sup>(1)</sup>	12800	4450 (3) <sup>(1)</sup>	5200

## Line pull for Certified Winch Version: USC

Rope Diameter	Line Pull (according to DNVGL) [lbf]				Line Pull (according to ABS) [lbf]			
	Cargo Winch		Lifting of Personnell Winch		Cargo Winch		Lifting of Personnell Winch	
	Last Layer	First Layer	Last Layer	First Layer	Last Layer	First Layer	Last Layer	First Layer
Ø 0.94 [in]	18787 (5) <sup>(1)</sup>	24250	7343 (5) <sup>(1)</sup>	9479	18787 (5) <sup>(1)</sup>	24250	8882 (5) <sup>(1)</sup>	11464
Ø 1.02 [in]	22842 (4) <sup>(1)</sup>	28219	7674 (4) <sup>(1)</sup>	9479	22842 (4) <sup>(1)</sup>	28219	9279 (4) <sup>(1)</sup>	11464
Ø 1.10 [in]	24151 (3) <sup>(1)</sup>	28219	8115 (3) <sup>(1)</sup>	9479	24151 (3) <sup>(1)</sup>	28219	9810 (3) <sup>(1)</sup>	11464

The line pull listed above are just for reference, for this application is strongly recommended to fill up the Winch Application Data Form available at the end of this catalogue and consult the Dana area contact person for final selection and validation.

## Other Ropes available

Working layer			1	2	3	4	5	6
Rope Diameter Ø 24 [mm]	Rope length	[m]	54	111	174	238	309	381
Rope Diameter Ø 28 [mm]	Rope length	[m]	47	96	151	208	271	-

## Other Ropes available

Working layer			1	2	3	4	5	6
Rope Diameter Ø 0,94 [in]	Rope length	[ft]	179	365	571	782	1014	1251
Rope Diameter Ø 1.10 [in]	Rope length	[ft]	154	316	497	684	891	-

Last indicated Layer is intended only as Storage

<sup>(1)</sup> Last working layer

Axial Piston Motor Fixed Displacement

Maximum Line pull at first layer

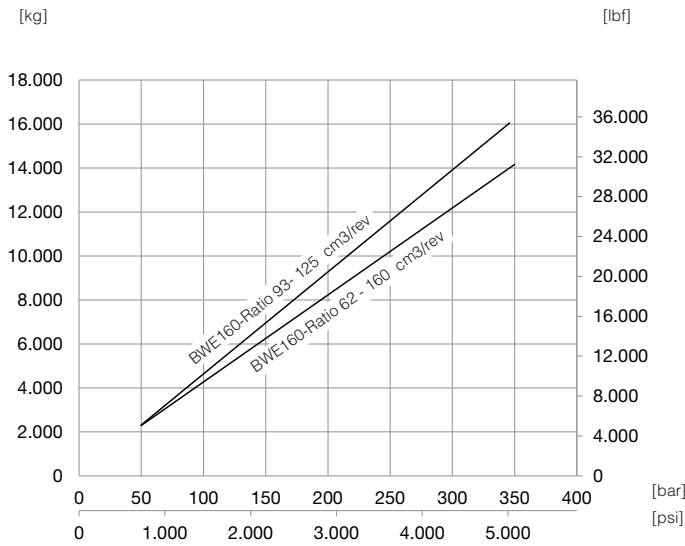

Maximum Speed at first layer

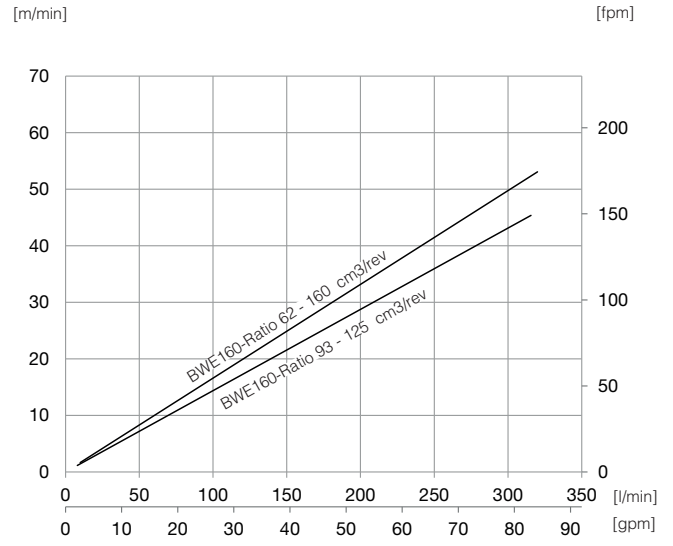

Axial Piston Motor Variable Displacement

Maximum Line pull at first layer

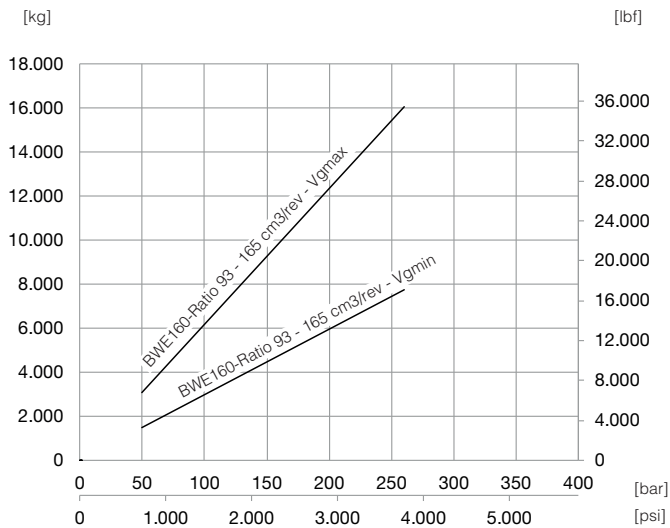

Maximum Speed at first layer

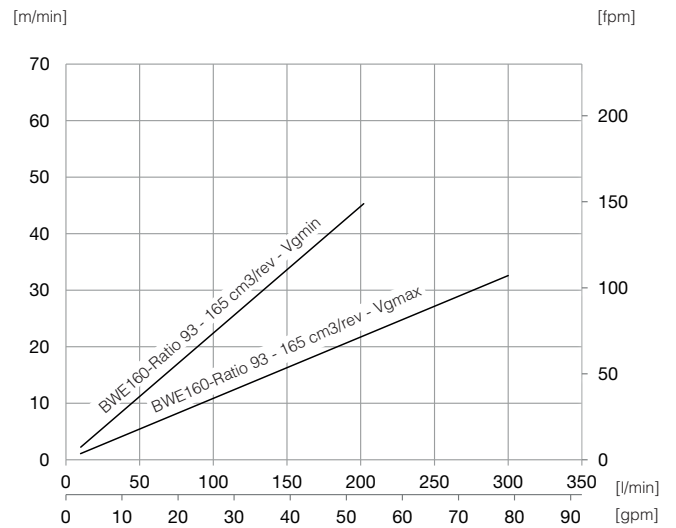

$Vg_{max} = 166.2 \text{ cm}^3/\text{rev}$  [10.13 in<sup>3</sup>/rev]  
 $Vg_{min} = 80 \text{ cm}^3/\text{rev}$  [4.88 in<sup>3</sup>/rev]

$Vg_{max} = 166.2 \text{ cm}^3/\text{rev}$  [10.13 in<sup>3</sup>/rev] - Max 300 l/min [79 gpm] allowed  
 $Vg_{min} = 80 \text{ cm}^3/\text{rev}$  [4.88 in<sup>3</sup>/rev] - Max 201 l/min [53 gpm] allowed

**Note:**

- All data shown in this page are ONLY FOR INFORMATION. The actual data will be issued according to Customer application and Duty Cycle.



**BREVINI<sup>®</sup>**

*Motion Systems*

**B**

Accessories	<b>B2</b>
Torque Sensor	<b>B4</b>
Universal Input Flange 00	<b>B5</b>
Brevini® Orbital Motor Fixed Displacement	<b>B6</b>
Brevini® Integrated Axial Piston Motor Fixed Displacement	<b>B7</b>
Brevini® Axial Piston Motor Fixed Displacement	<b>B8</b>
Brevini® Axial Piston Motor Variable Displacement	<b>B9</b>
Control Valve	<b>B10</b>
Certifications	<b>B12</b>
Installation Advice	<b>B13</b>
Lubrication	<b>B14</b>
Selection Winch Technical Sheet	<b>B16</b>

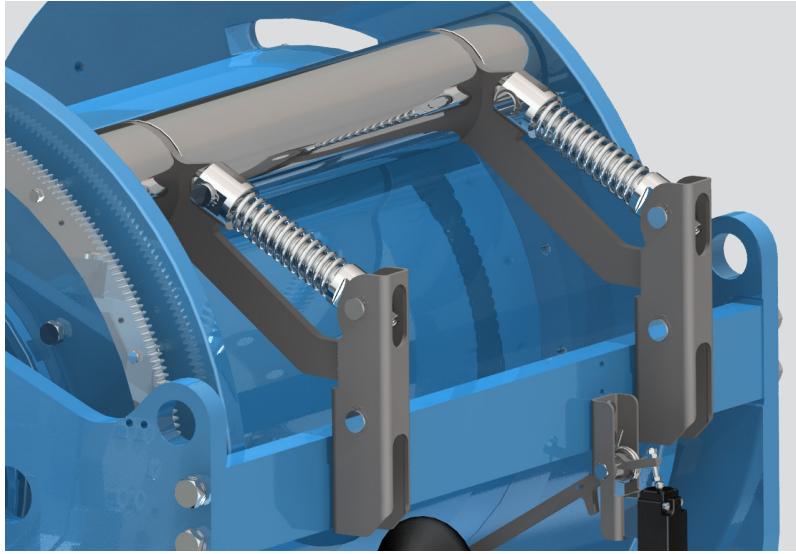
**Pressure Roller**

The pressure roller ensures the correct winding of the rope on the drum and is highly recommended when there is more than one layer of rope wound on the drum.

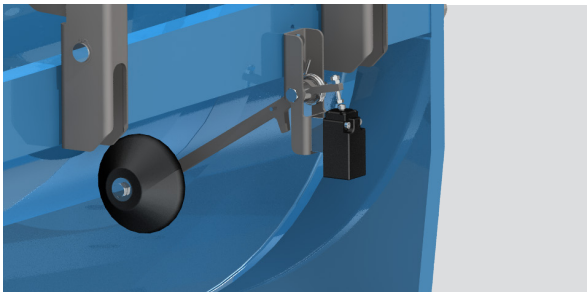
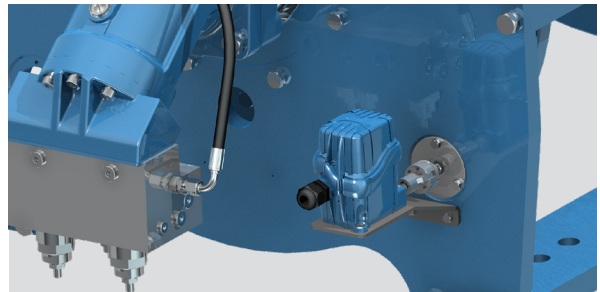
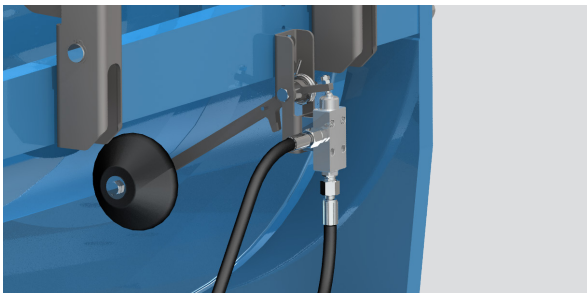
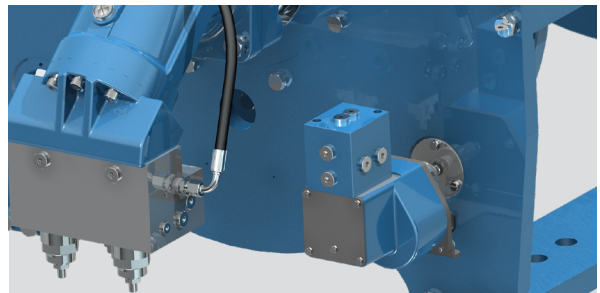
**Safety Wraps Limit Switch****Minimum Electric Limit Switch****Min/Max Rotative Electric Limit Switch****Minimum Hydraulic Limit Switch****Min/Max Rotative Hydraulic Limit Switch**

These devices ensure a minimum number of wraps always needed to be wound on the drum for safety reason, to avoid rope breakage causing the fall of the load.

Rotative Switches also ensure that the maximum rope capacity of the drum is not exceeded.

### Proximity Speed Sensor

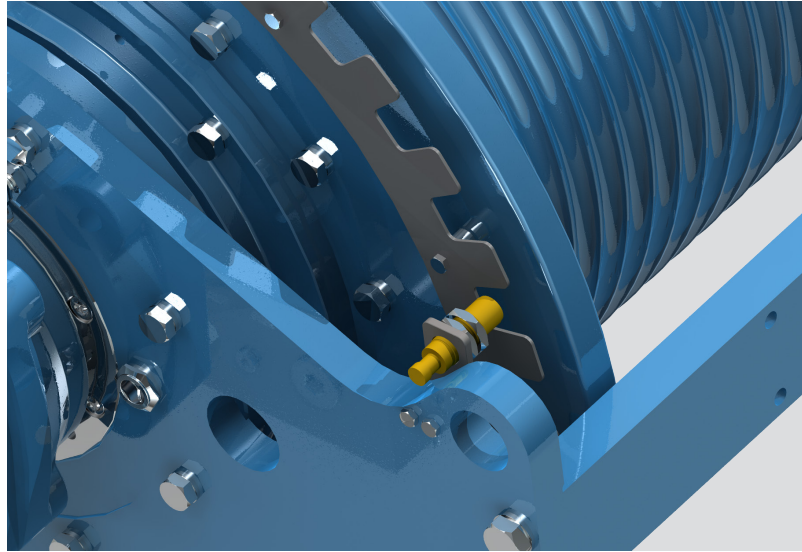

Our stainless-steel Proximity sensor is used to read the rotational speed of the drum, providing the user an information of the rope speed. Using two sensors is also possible to define the sense of rotation of the drum, giving information about lifting or lowering of the load.

### Rotative Speed Sensor

#### Encoder

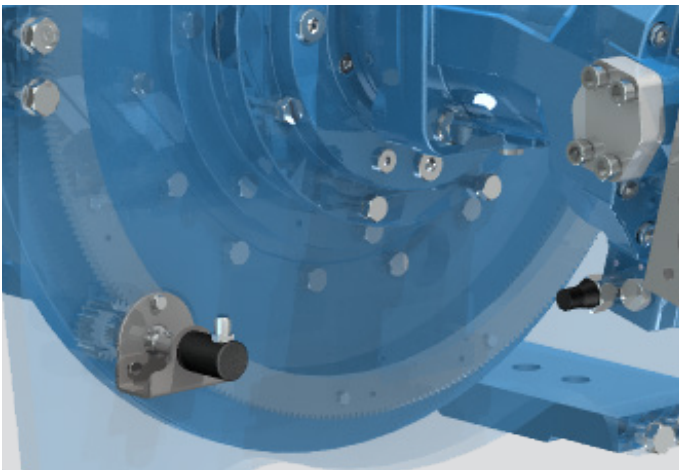

#### Hall Effect Speed Sensor

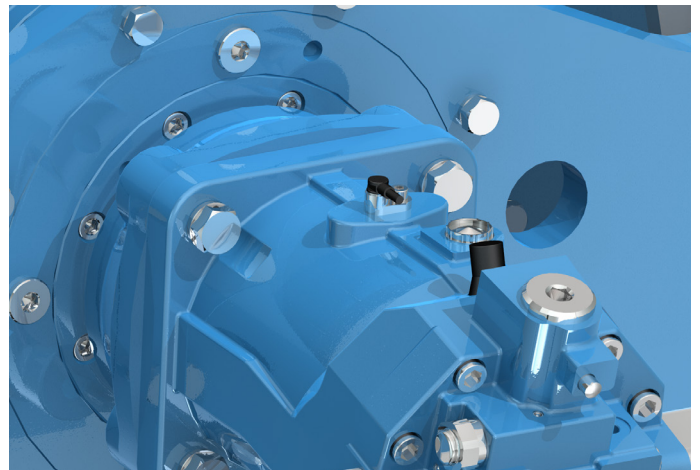

The Encoder reads the speed of the drum and the rotation direction, providing information on the speed of the rope. Using an absolute encoder is also possible to collect information about the length of the rope still on the drum or unwound. It is also possible to have the rotative speed sensor on the Brevini® Hydraulic Motor.

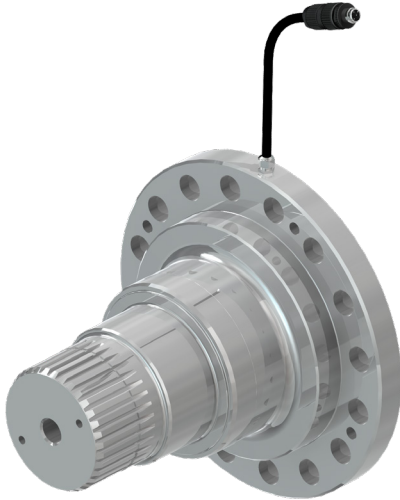

This sensor embedded in the winch is able to measure the torque applied to the drum at any time, during winch operation.

The unique design and electronic features are made to provide high precision and reliability.

Fully tested before they leave the factory.

Technical Data											
Available Winch Size <sup>(1)</sup>	BWE015 - BWE025 - BWE035 - BWE055 - BWE070 BWE085 - BWE105 - BWE125 - BWE160										
Output signal	4 ÷ 20 [mA]										
Full Scale <sup>(2)</sup>	180% of max Line pull										
Operating Temperature	-20° ÷ 40° [°C] / -4° ÷ 104° [°F]										
Functional Safety <sup>(3)</sup>	Available with or without redundancy										
International Protection	IP67 (electronic device)										
<b>Integrated signal converter</b>											
<b>Cable length 0.15 m [0.49 ft]</b>											
<b>Connector M12x1.5 - 4 pin</b>											
	<table border="1"> <thead> <tr> <th>Pin number</th> <th>Connections</th> </tr> </thead> <tbody> <tr> <td>1</td> <td>+ Supply</td> </tr> <tr> <td>2</td> <td>- Supply</td> </tr> <tr> <td>3</td> <td>OUT 1</td> </tr> <tr> <td>4</td> <td>OUT 2</td> </tr> </tbody> </table>	Pin number	Connections	1	+ Supply	2	- Supply	3	OUT 1	4	OUT 2
	Pin number	Connections									
	1	+ Supply									
	2	- Supply									
3	OUT 1										
4	OUT 2										

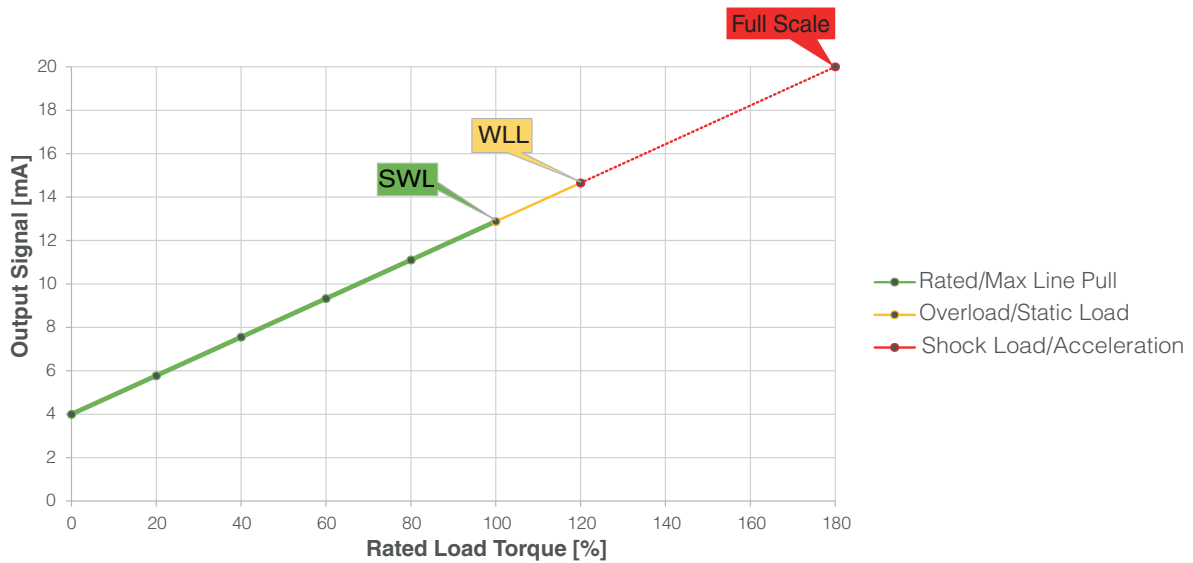

<sup>(1)</sup> Not available for lifting of personnel application

<sup>(2)</sup> 180% has to be considered as Full Scale of the Sensor ONLY, this setting shall not be used as winch overload indicator, shall not be considered as working load limit (WLL) or as the max performance of the winch

<sup>(3)</sup> The redundant version can be used to build a system that achieves PLd (according to EN 13849-1), if the system is able to reach PLd (or higher) overall



The universal input enables the coupling of many types of motorizations by means of a special flange and adapter coupling.

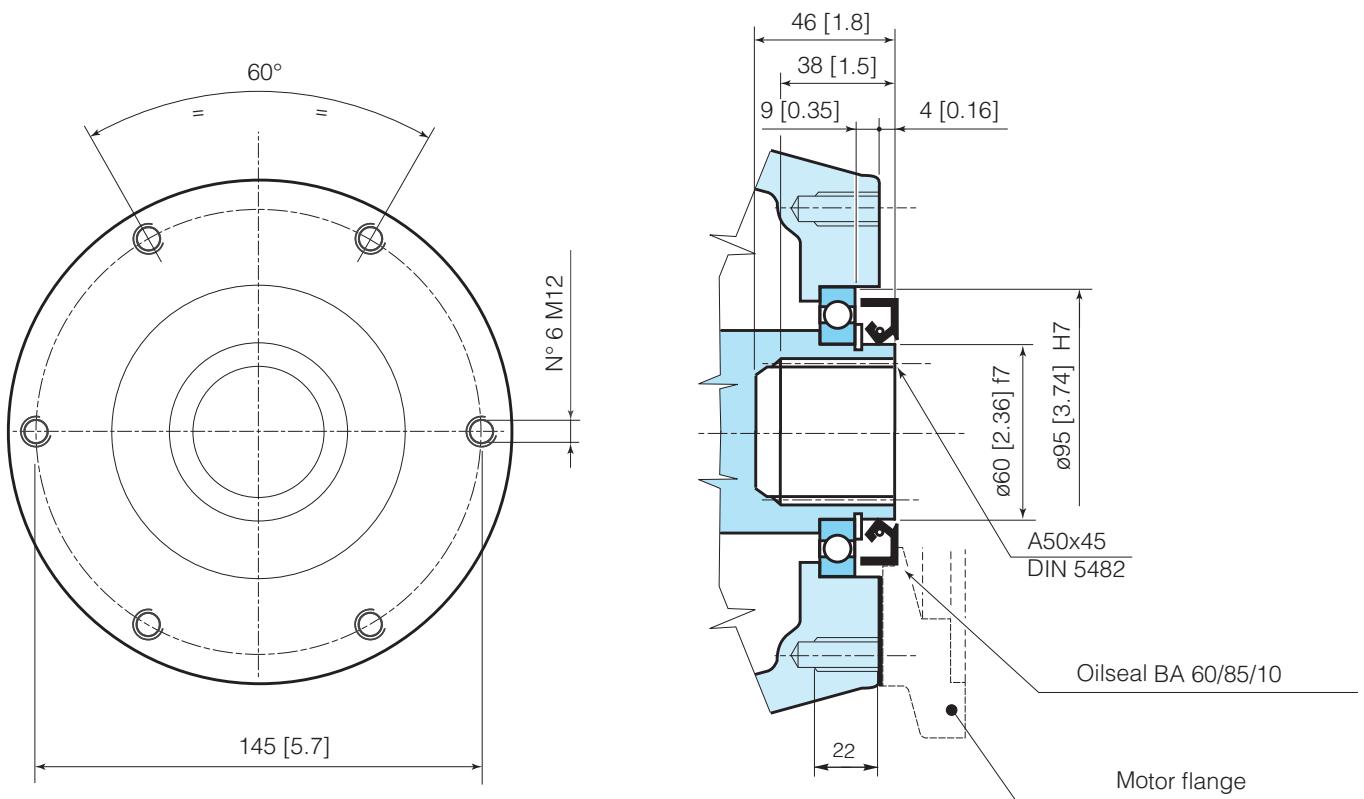
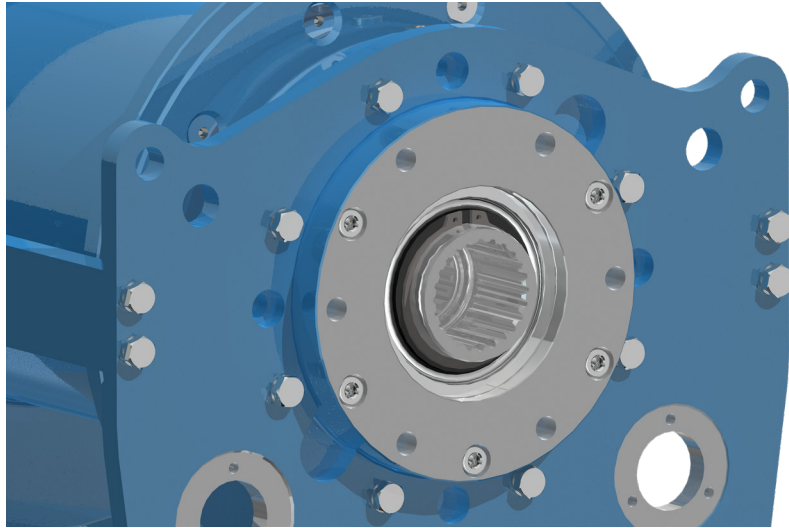

# Brevini® ORBITAL MOTOR FIXED DISPLACEMENT

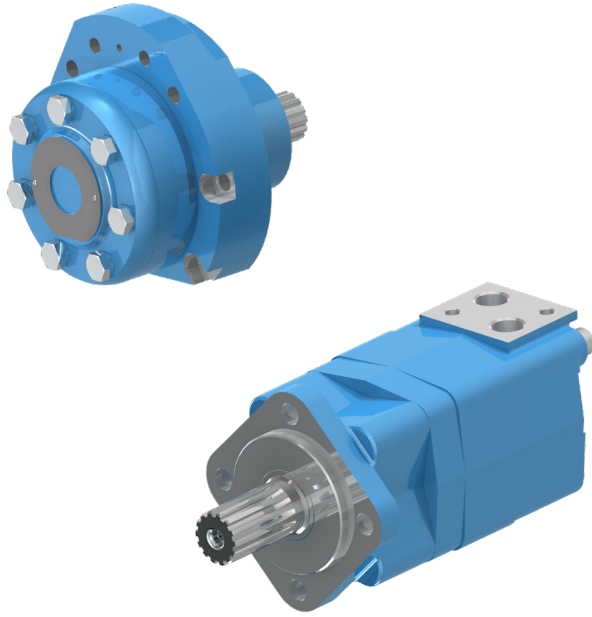

Our range of Orbital motor is the perfect fit for all the winch application where high torque and low speed are required.

The BRZV range able to reach peak pressure of 225bar, can offer different displacement between 50cc and 400cc, compact and reliable, is recommended when compactness is a plus.

The HR range able to reach peak pressure of 315bar, can offer different displacement between 80cc and 400cc, robust and versatile, is recommended when efficiency is a plus.

All the motors are available with brake control valve, single or double-overcenter.

## BRZV Orbital Motors Working Conditions

Technical Data									
Size				80	100	130	160	200	250
Displacement		$V_{g\ max}$	cm <sup>3</sup> /rev [in <sup>3</sup> /rev]	80.4 [4.9]	100 [6.1]	125.7 [7.66]	160 [9.76]	200 [12.2]	250 [15.2]
	Max pressure	Cont.	$p_{nom}$	bar [psi]	175 [2537]	175 [2537]	175 [2537]	175 [2537]	175 [2537]
Peak		$p_{max}$	bar [psi]	225 [3262]	225 [3262]	225 [3262]	225 [3262]	225 [3262]	225 [3262]
Max speed		$n_{0max}$	rpm	746	600	477	375	300	240
Max flow		$q_{max}$	l/min [gpm]	60 [15.9]	60 [15.9]	60 [15.9]	60 [15.9]	60 [15.9]	60 [15.9]

## HR Orbital Motors Working Conditions

Technical Data									
Size				80	100	130	160	200	
Displacement		$V_{g\ max}$	cm <sup>3</sup> /rev [in <sup>3</sup> /rev]	80.4 [4.9]	100 [6.1]	125.7 [7.66]	160 [9.76]	200 [12.2]	
	Max pressure	Cont.	$p_{nom}$	bar [psi]	210 [3045]	210 [3045]	210 [3045]	210 [3045]	210 [3045]
Peak		$p_{max}$	bar [psi]	310 [4495]	310 [4495]	310 [4495]	310 [4495]	310 [4495]	
Max speed		$n_{0max}$	rpm	932	750	596	468	375	
Max flow		$q_{max}$	l/min [gpm]	75 [19.8]	75 [19.8]	75 [19.8]	75 [19.8]	75 [19.8]	

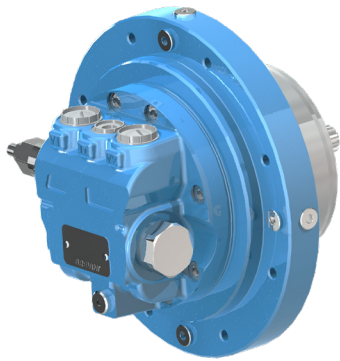

The B5VA is the unique solution that Dana offer to have the best compromise between compactness and performances.

Able to reach a peak pressure of 350bar, available in three different sizes, is recommended for all the application where speed, torque and efficiency are required.

The integrated brake control valve, with single or double over-center, is the perfect blend of functionality and compactness.

## B5VA Integrated Axial Piston Motors Working Conditions

Technical Data						
Size				21	37	68
Displacement		$Vg_{max}$	cm <sup>3</sup> /rev [in <sup>3</sup> /rev]	21.00 [1.28]	37.04 [2.26]	68 [4.15]
	Max pressure	Cont.	$p_{nom}$	bar [psi]	300 [4351]	300 [4351]
Peak		$p_{max}$	bar [psi]	350 [5076]	350 [5076]	350 [5076]
Max speed		$n_{0max}$	rpm	2857	2430	2205
Max flow		$q_{max}$	l/min [gpm]	60 [15.8]	90 [23.77]	150 [39.6]

# Brevini® SH11C AXIAL PISTON MOTOR FIXED DISPLACEMENT

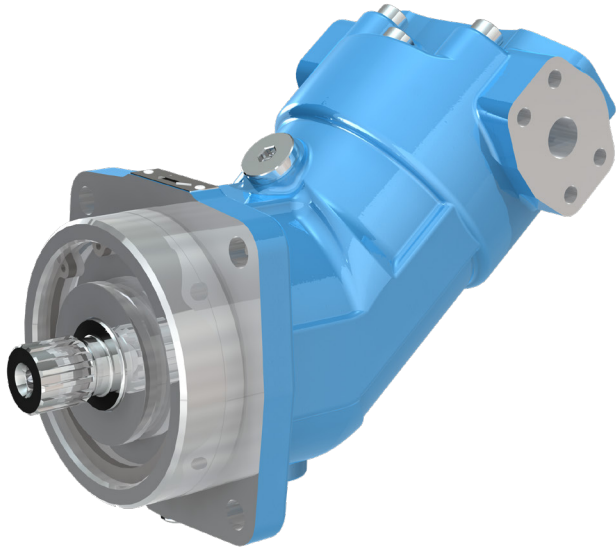

SH11C motors are a family of fixed displacement, bent axis piston design for operation in both open and closed circuit.

The proven design incorporating the lens shape valve plate, the high quality components and manufacturing techniques make the SH11C motors able to provide up to 430 bar [6235 psi] continuous and 480 bar [6960 psi] peak performance.

Fully laboratory tested and field proven, these units provide maximum efficiency and long life. Heavy duty bearings permit high radial and axial loads. Versatile design includes a variety of port plates, shaft ends and valves package that will fit the SH11C motors to any application both industrial and mobile. SH11C motors are available in both ISO and SAE version.

## SH11C Axial Piston Motors Working Conditions

Technical Data							
Size				075	090	125	160
Displacement		$V_{g_{max}}$	cm <sup>3</sup> /rev [in <sup>3</sup> /rev]	77.82 [4.747]	86.23 [5.26]	124.8 [7.613]	163.9 [9.998]
	Max pressure	Cont.	$p_{nom}$	bar [psi]	430 [6235]	430 [6235]	430 [6235]
Peak		$p_{max}$	bar [psi]	480 [6960]	480 [6960]	480 [6960]	480 [6960]
Max speed		$n_{0max}$	rpm	4500	4500	4000	3600
Max flow		$q_{max}$	l/min [gpm]	350 [92.4]	388 [102.5]	500 [132]	590 [155.76]

### Note:

The information stated in this page are only for reference, for detailed information see the dedicated catalog on official site [Dana-Industrial.com](http://Dana-Industrial.com)

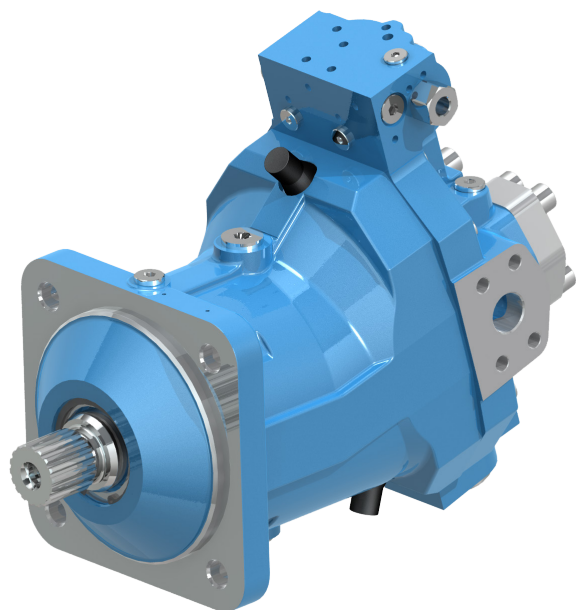

SH9V series are a family of variable displacement motors, bent axis piston design for operation in both open and closed circuit.

The proven design incorporating the lens shape valve plate, the high quality components and manufacturing techniques make the SH9V series motors able to provide up to 430 bar [6235 psi] continuous and 480 bar [6960 psi] peak performance.

Long life heavy duty bearings permit high radial and axial loads. Versatile design includes a variety of control and shaft ends that will adapt the SH9V series motors to any application both industrial and mobile.

## SH9V Axial Piston Motors Working Conditions

Technical Data						
Size				085	115	165
Displacement		$V_{g_{max}}$	cm <sup>3</sup> /rev [in <sup>3</sup> /rev]	85.3 [5.203]	115.7 [7.05]	166.2 [10.13]
	Standard	$V_{g_{min}}$	cm <sup>3</sup> /rev [in <sup>3</sup> /rev]	40 [2.44]	56 [3.416]	80 [4.88]
	Minimum possible	$V_{g_{min}}$	cm <sup>3</sup> /rev [in <sup>3</sup> /rev]	17 [1.03]	23 [1.403]	33 [2.01]
Max pressure	Cont.	$p_{nom}$	bar [psi]	430 [6235]	430 [6235]	430 [6235]
	Peak	$p_{max}$	bar [psi]	480 [6960]	480 [6960]	480 [6960]
Max flow		$q_{max}$	l/min [gpm]	341 [90.02]	411 [108.5]	515 [135.96]

## Controls and Accessories suggested

Electric two position Control 2EE

The 2EE Control Version with the pressure override allows the motor to swivel to  $V_{g_{max}}$  when the pressure setting is reached. The motor displacement is adjusted to  $V_{g_{min}}$  when the solenoid valve is switched on and if the operating pressure rises beyond the pressure setting, the pressure limiting device overrides the electric two positions control and the motor swivels out to  $V_{g_{max}}$ . Swivel range is from  $V_{g_{min}}$  to  $V_{g_{max}}$ .

## Hall Effect Speed Sensor

TW and TZ sensors are available on all the Motor Displacement, see the dedicated catalogue.

### Note:

The information stated in this page are only for reference, for detailed information see the dedicated catalog on official site [Dana-Industrial.com](http://Dana-Industrial.com)

Brake Control Valve specifically designed for winch operation.

This valve fits perfectly with our hydraulic motor BRZV and HR Series, able to maximize the winch performances.

Single Overcenter Valve as a standard and Double Overcenter Valve as option.

## Single Overcenter Valve

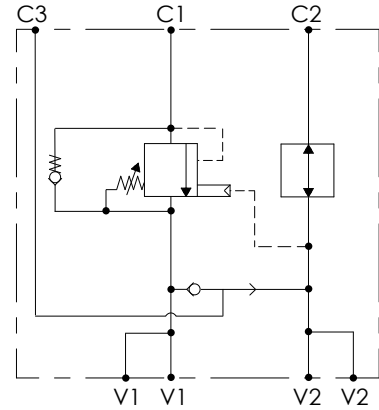
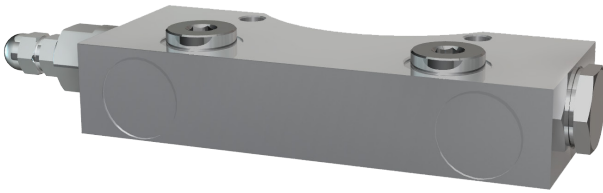

### Technical Data

<b>Max operation pressure</b>	420 [bar] / 6091 [psi]
<b>Max Oil Flow</b>	60 [l/min] / 15.8 [gpm]
<b>Pilot Ratio</b>	4.3:1 [i]

## Single Overcenter Valve

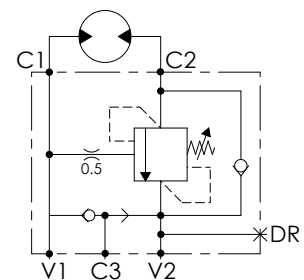
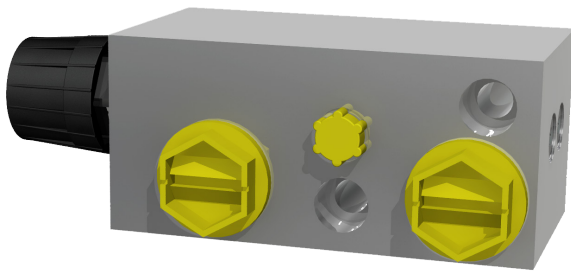

### Technical Data

<b>Max operation pressure</b>	350 [bar] / 5076 [psi]
<b>Max Oil Flow</b>	150 [l/min] / 40.0 [gpm]
<b>Pilot Ratio</b>	4:1 [i]

Brake Control Valve specifically designed for winch operation.

This valve fits perfectly with our hydraulic motors SH11C and SH9V Series, able to maximize the winch performances. It also incorporates a pressure reducer cartridge on the brake line.

Double Overcenter Valve as a standard and Single Overcenter Valve as option.

## Double Overcenter Valve

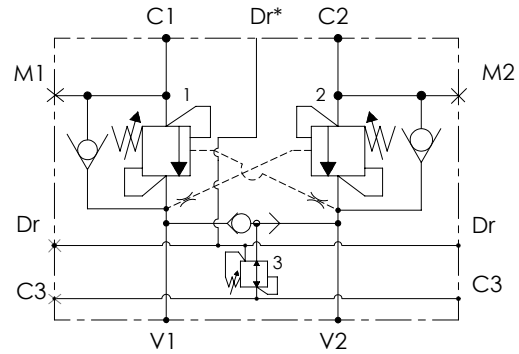
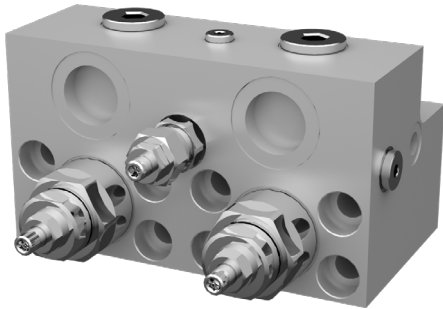

Technical Data	
Max operation pressure	400 [bar] / 5750 [psi]
Max Oil Flow	320 [l/min] / 85.3 [gpm]
Pilot Ratio	6:1 [i]
Max operation brake pressure	70 [bar] / 1000 [psi]

## Single Overcenter Valve

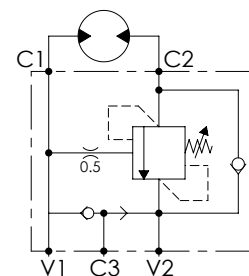
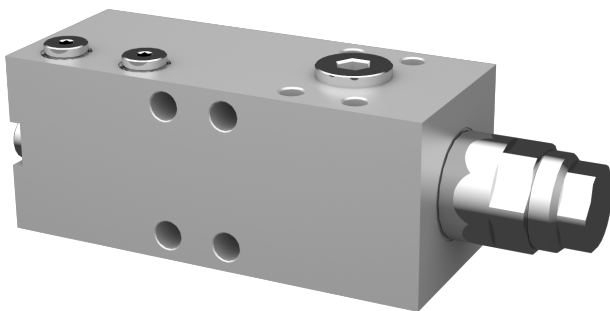

Technical Data	
Max operation pressure	500 [bar] / 7190 [psi]
Max Oil Flow	320 [l/min] / 85.3 [gpm]
Pilot Ratio	6:1 [i]

New BWE Winch Series is designed to meet the majority of global Marine and Offshore Standards.

The winches configurations shown in this catalog are already Type Approved from DNV-GL and ABS, and already compliant to API-2c.

Other configurations and certifications have to be requested and evaluated case-by-case.





The winch support frame must be fixed securely to a good level surface of adequate thickness. Use quality and grade fixing nuts and bolts with correct torque setting according to dimensional drawings.

A and B ports of the proportional directional valve must be open to tank while the control valve is in neutral position. This prevents any build up of hydraulic pressure which could cause the negative brake to accidentally open.

with Double Overcenter Valve

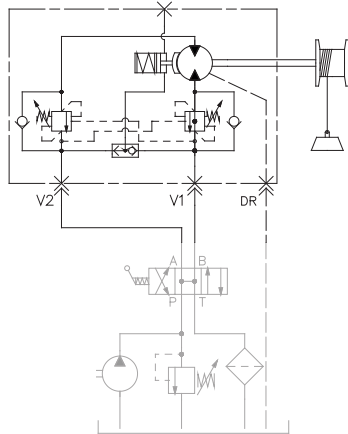

with Single Overcenter Valve

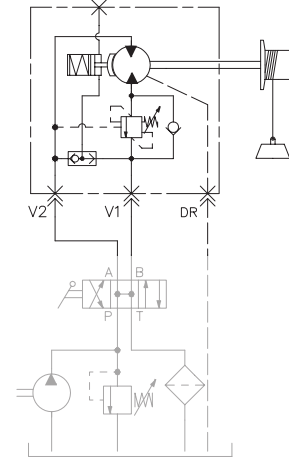

Lifting of Personnel  
with Double Overcenter Valve

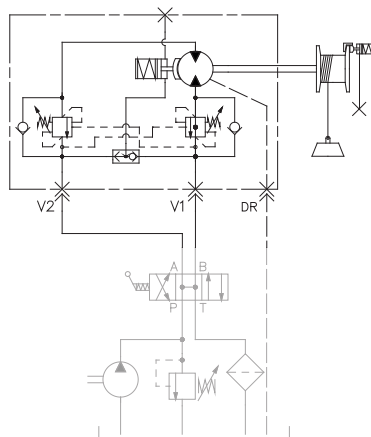

Lifting of Personnel  
with Single Overcenter Valve

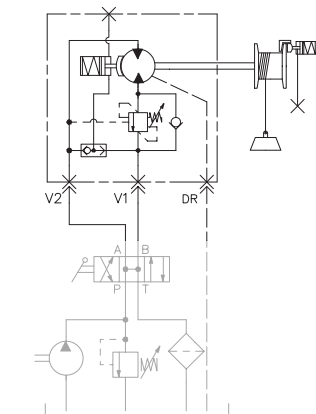

The supply, return and drain hoses must all be of adequate internal dimensions to support the maximum working and drainage flow rates. Draining hoses must always flow directly to the oil reservoir.

Standard hoisting direction is "01", clockwise. For anti-clockwise, "02", hoisting direction please specify when ordering.

The Brevini® winches are designed to hold 5 layers of cable of which 3 windings always present at the 1st layer. Carefully follow the cable manufacturers instructions and respect all guidelines and rules ordering.

For Hydraulic oil use mineral oils with wear resistant additives, type HLP (DIN51524 ) or HM (ISO 6743/4) and viscosity according to ISO VG46. Recommended filtration 10µm absolute or β10-75.

For the Brevini® motorized winches, use gear mineral oil with E.P. characteristics according to ISO VG150 or SAE 80W/90. For applications exposed to extreme temperature changes, use a synthetic oil with E.P. properties, with minimum viscosity of ISO VG150 or SAE 80W/90. For the Brevini® motorized winches, equipped with sprag clutches, use gear mineral oil ISO VG150 with NO E.P. characteristics.

It is recommended to turn on the machinery without load for 5÷10 minutes at start-up.

## Fundamental characteristics of the oils

The important parameters to consider when choosing the type of oil are:

- viscosity at nominal operating conditions
- additives

The same oil must lubricate the bearings, the gears and the brake.

All these components work inside the same box, in different operating conditions.

## Viscosity

Nominal viscosity refers to a temperature of 40°C, but rapidly decreases as the temperature increases.

If the gear unit operating temperature is between 50°C and 70°C, a nominal viscosity can be chosen according to the following guide table, choosing the highest viscosity if the highest operating temperature is foreseen.

## Additives

In addition to the normal anti-foaming and antioxidant additives, it is important to use lubricating oils with additives that provide EP (extreme pressure) and antiwear properties, according to ISO 6743-6 L-CKC or DIN 51517-3 CLP. The lower the gear unit output speed is the more marked the EP characteristics of the products have to be. It should be remembered that the chemical compounds replacing hydrodynamic lubrication are formed to the detriment of the original EP load.

Therefore, with very low speeds and high loads it is important to respect the maintenance intervals so as not to excessively diminish the lubricating characteristics of the oil.

## Types of oils

The oils available generally belong to three large families.

- Mineral oils
- Polyalphaolefin (PAO) synthetic oils
- Polyalkylene glycol (PAG) synthetic oils

The most suitable choice is generally tied to the conditions of use.

Gear units that are not particularly loaded and with a discontinuous operating cycle, without considerable temperature ranges, can be lubricated with mineral oil.

In cases of heavy use, when the gear units are very loaded and in a continuous way, with resultant temperature increase, it is best to use polyalphaolefin synthetic lubricants.

The use of polyalkylene glycol oils is not allowed as they are not compatible with other oils and are often completely mixable with water: this phenomenon is particularly dangerous because it is not noticed, but rapidly diminishes the lubricating properties of the oil. Moreover, these lubricants can be chemically active against the oil seals and paint inside the gear unit.

In addition to the above, there are also hydraulic oils and oils for the food industry.

The former are used for the command of negative brakes.

The latter have a specific use in the food industry since they are special products that are not harmful to health.

Given below is table of lubricants, proposed by the best-known producers, with characteristics suitable for the lubrication of Brevini® gear units.

**Brevini® winches are supplied with lubricant: mineral oil ISO VG150.**

For detail instructions about installation and maintenance refers to Dana IMM that you can find in website [Dana-Industrial.com](http://Dana-Industrial.com)

## Contamination

During normal operation, due to running-in of the surfaces, metallic micro-particles will inevitably form in the oil.

This contamination can shorten the life of the bearings, resulting in early breakdown of the gear unit.

To limit and control this phenomenon, without resorting to frequent and costly oil changes, a suitable auxiliary oil circulation system with filtering and cooling of the oil must be provided.

This system offers the dual advantage of controlling the level of contamination through the use of special filters and stabilizing the operating temperature at a level more suitable for ensuring the required viscosity.

For lubrication problems with gear units intended for particular uses, regarding the construction type and operating parameters, it is advisable to contact the Dana Sales Dept.

Manufacturer	Mineral oils			Poly-Alpha-Olefin synthetic oils (PAO)		
	ISO VG	ISO VG	ISO VG	ISO VG	ISO VG	ISO VG
	150	220	320	150	220	320
<b>ADDINOL</b>	Eco Gear 150 M	Eco Gear 220 M	Eco Gear 320 M	Eco Gear 150 S	Eco Gear 220 S	Eco Gear 320 S
<b>ARAL</b>	Degol BG 50 Plus	Degol BG 220 Plus	Degol BG 320 Plus	Degol PAS 150	Degol PAS 220	Degol PAS 320
<b>BP</b>	Energol GR-XP 150	Energol GR-XP 220	Energol GR-XP 320	Enersyn EPX 150	Enersyn EPX 220	Enersyn EPX 320
<b>CASTROL</b>	Alpha SP 150	Alpha SP 220	Alpha SP 320	Alphasyn EP 150	Alphasyn EP 220	Alphasyn EP 320
<b>CEPSA</b>	Engranajes XMP 150	Engranajes XMP 220	Engranajes XMP 320	-	Aerogear Synt 220	Aerogear Synt 320
<b>CHEVRON</b>	-	-	-	Tegra Synthetic Gear 150	Tegra Synthetic Gear 220	Tegra Synthetic Gear 320
<b>ENI</b>	Blasia 150	Blasia 220	Blasia 320	Blasia SX 150	Blasia SX 220	Blasia SX 320
<b>FUCHS</b>	Renolin CLP Gear Oil 150	Renolin CLP Gear Oil 220	Renolin CLP Gear Oil 320	Renolin Unisyn CLP 150	Renolin Unisyn CLP 220	Renolin Unisyn CLP 320
<b>KLÜBER</b>	Klüberoil GEM 1-150 N	Klüberoil GEM 1-220 N	Klüberoil GEM 1-320 N	Klübersynth GEM 4-150 N	Klübersynth GEM 4-220 N	Klübersynth GEM 4-320 N
<b>LUBRITECH</b>	Gearmaster CLP 150	Gearmaster CLP 220	Gearmaster CLP 320	Gearmaster SYN 150	Gearmaster SYN 220	Gearmaster SYN 320
<b>MOBIL</b>	Mobilgear XMP 150	Mobilgear XMP 220	Mobilgear XMP 320	Mobil SHC Gear 150	Mobil SHC Gear 220	Mobil SHC Gear 320
<b>MOBIL</b>	-	-	-	SHC 629	SHC 630	SHC 632
<b>MOLIKOTE</b>	L-0115	L-0122	L-0132	L-2115	L-2122	L-2132
<b>NILS</b>	Ripress EP 150	Ripress EP 220	Ripress EP 320	Atoil Synth PAO 150	-	Atol Synth PAO 320
<b>PANOLIN</b>	-	-	-	EP Gear Synth 150	EP Gear Synth 150	EP Gear Synth 150
<b>Q8</b>	Goya NT 150	Goya NT 220	Goya NT 320	El Greco 150	El Greco 220	El Greco 320
<b>REPSOL</b>	Super Tauro 150	Super Tauro 220	Super Tauro 320	Super Tauro Sintetico 150	Super Tauro Sintetico 220	Super Tauro Sintetico 320
<b>SHELL</b>	Omala S2 G 150	Omala S2 G 220	Omala S2 320	Omala S4 GX 150	Omala S4 GX 220	Omala S4 GX 320
<b>SHELL</b>	-	-	-	Morlina S4 B 150	Morlina S4 B 220	Morlina S4 B 320
<b>SUNOCO</b>	Sun EP 150	Sun EP 220	Sun EP 320	-	-	-
<b>TEXACO</b>	Meropa 150	Meropa 220	Meropa 320	Pinnacle EP 150	Pinnacle EP 220	Pinnacle EP 320
<b>TOTAL</b>	Carter EP 150	Carter EP 220	Carter EP 320	Carter SH 150	Carter SH 220	Carter SH 320
<b>TRIBOL</b>	1100/150	1100/220	1100/320	-	-	1510/320



**BREVINI<sup>®</sup>**

*Motion Systems*

# SELECTION WINCH TECHNICAL SHEET



Date \_\_\_\_\_ Salesman \_\_\_\_\_  
Subsidiary \_\_\_\_\_ Requested lead time for quotation \_\_\_\_\_

Customer \_\_\_\_\_ Customer type [OEM; End User,..] \_\_\_\_\_  
Contact person \_\_\_\_\_ Market Sector \_\_\_\_\_  
Product to be replaced \_\_\_\_\_ or new application  Machine Type \_\_\_\_\_  
Winches q.ty / batch \_\_\_\_\_ Winches q.ty / year \_\_\_\_\_  
Requested Lead Time Prototype \_\_\_\_\_ Requested Lead Time Series \_\_\_\_\_  
Target Price Prototype \_\_\_\_\_ Target Price Series \_\_\_\_\_  
Description of the application \_\_\_\_\_

### Winch characteristics

Winch type Lifting  Pulling  Lifting person  Lifting person + cargo   
Drum Smooth  Grooved  Helical left  Helical right  Lebus style left  Lebus style right

Req. Line pull on drum [kg]		Rope diameter [mm]	
At layer		Storage Rope Length[m]	
Req. Speed on drum [m/min]		Working Rope Length[m]	
At layer			

FEM class or Duty cycle available		Certifications	
		Standards	

Ambient temperature [°C]		Operating temperature [°C]	
--------------------------	--	----------------------------	--

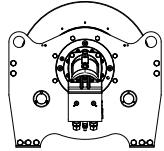
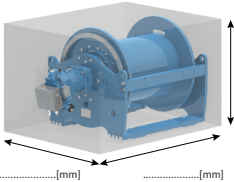
Exit of the rope 	maximum dimension or other limitations 	Drawings or indications
---	---	-------------------------

### Motor power supply



Motor not included into supply  Electric  Hydraulic

Model*	Manufacturer*
Flange type*	Shaft type*

Electric	Hydraulic
Supply Frequency [Hz]	Max pressure available at the motor [bar]
Supply Voltage [V]	Working Pressure [bar]
N. of Poles*	Displacement [cc/rev]* min: _____ max: _____
	Max oil flow available at the motor[l/min]

\* Fill up only if the motor is not included into supply

### Accessories

Rope**	Included <input type="checkbox"/>	Not included <input type="checkbox"/>	Pressure roller**	Included <input type="checkbox"/>	Not included <input type="checkbox"/>
Encoder**	Included <input type="checkbox"/>	Not included <input type="checkbox"/>	Press. Roller Limit switch	Electric <input type="checkbox"/>	Hydr. <input type="checkbox"/>
Roller fairleader**	Included <input type="checkbox"/>	Not included <input type="checkbox"/>		Min <sub>(empty drum)</sub> <input type="checkbox"/>	Max <sub>(full drum)</sub> <input type="checkbox"/>
Rotative Limit switch**	Included <input type="checkbox"/>	Not included <input type="checkbox"/>	Mounting position		<input type="checkbox"/>
Auxiliary Brake**	Included <input type="checkbox"/>	Not included <input type="checkbox"/>			<input type="checkbox"/>
Torque limiter**	Included <input type="checkbox"/>	Not included <input type="checkbox"/>			<input type="checkbox"/>
Drum Rev. Counter**	Included <input type="checkbox"/>	Not included <input type="checkbox"/>	Painting (Cycle/RAL/gloss)		
Others:	Included <input type="checkbox"/>	Not included <input type="checkbox"/>			

\*\* if the customer has special requirements about accessories please add the specification as attachment

Notes/ Other special requests

---

Attachments Yes  No





**BREVINI<sup>®</sup>**

*Motion Systems*



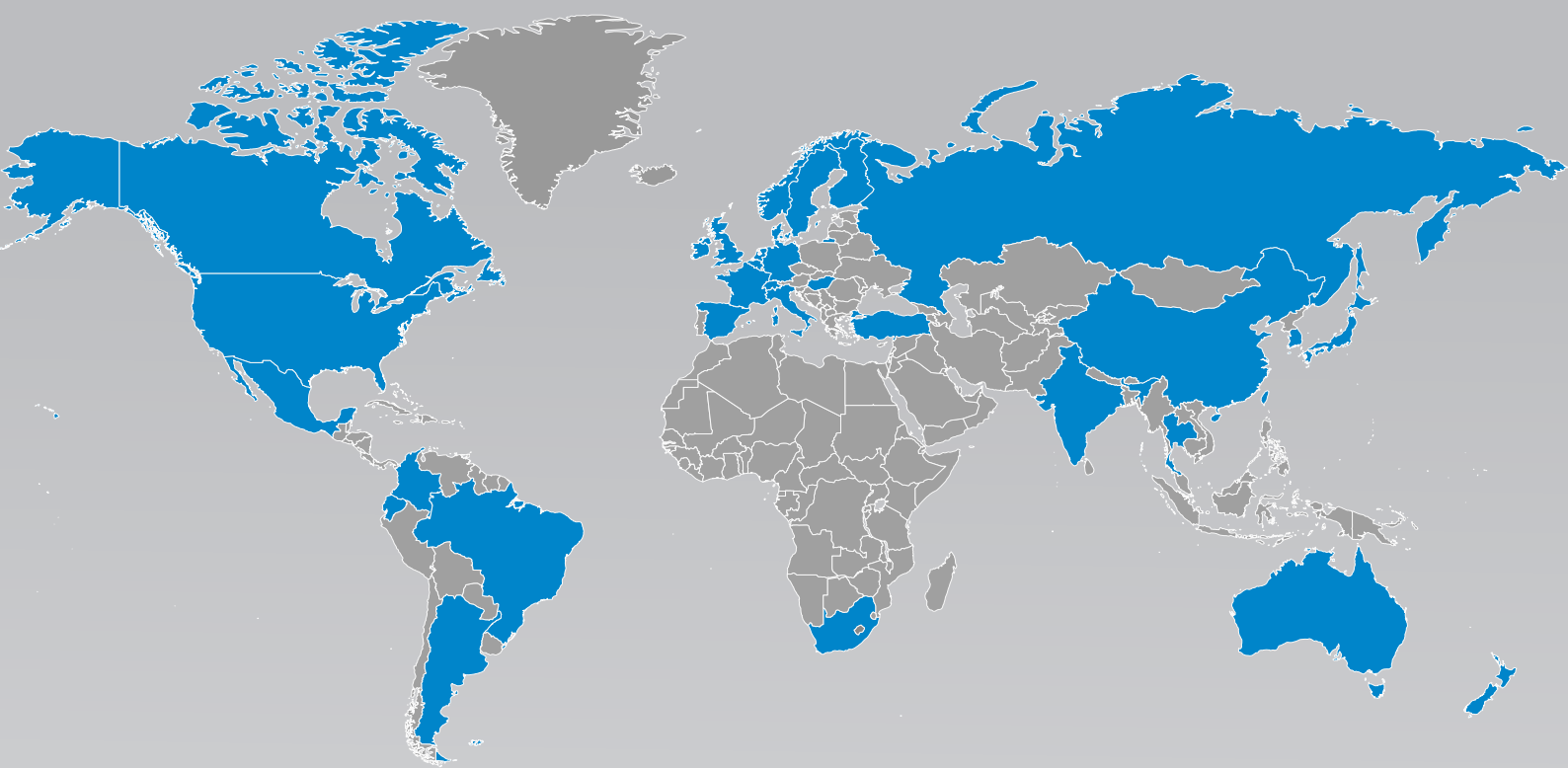

# Technologies Customized to Every Part of the Globe

With a presence in 33 countries, Dana Incorporated boasts more than 145 engineering, manufacturing, and distribution facilities. Our worldwide network of local service centers provides assurance that each customer will benefit from the local proximity and responsiveness.

## About Dana Incorporated

Dana is an integral partner for virtually every major vehicle and engine manufacturer worldwide. We are a leading supplier of drivetrain, sealing, and thermal technologies to the global automotive, commercial-vehicle, and off-highway markets. Founded in 1904, we employ thousands of people across six continents.

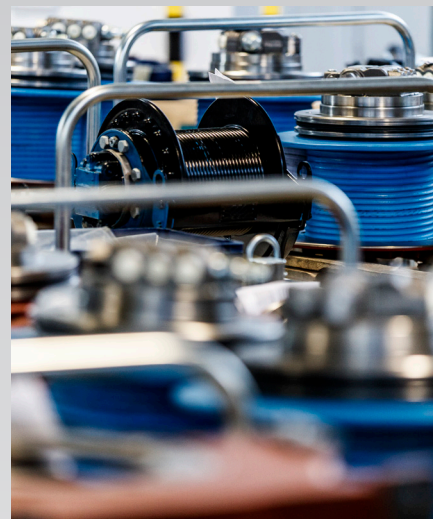
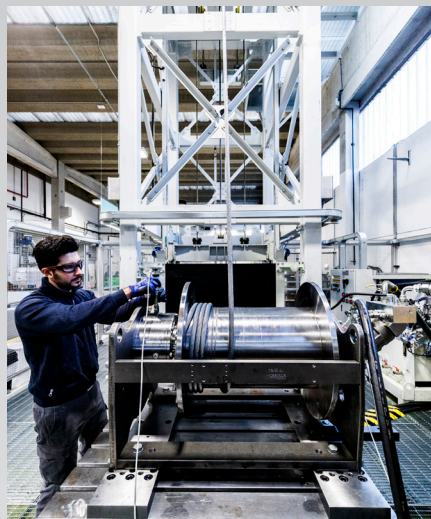

## About Dana Off-Highway Drive and Motion Technologies

Dana delivers fully optimized Spicer® drivetrain and Brevini® motion systems to customers in construction, agriculture, material-handling, mining, and industrial markets. We bring our global expertise to the local level with technologies customized to individual requirements through a network of strategically located technology centers, manufacturing locations, and distribution facilities.

Learn more about Dana's drivetrain and motion systems at [dana.com/offhighway](https://dana.com/offhighway).

## Dana-Industrial.com

### Application Policy

Capacity ratings, features, and specifications vary depending upon the model and type of service. Application approvals must be obtained from Dana; contact your representative for application approval. We reserve the right to change or modify our product specifications, configurations, or dimensions at any time without notice.



**BREVINI®**

*Motion Systems*