



Main Features

- Stainless steel 1.4404/1.4435 (316L)
- Sterilization in place (SIP)
- Hygienic connections according to several standards
- Cleaning in place (CIP)
- 3A
- FDA conform

Applications

- Food and Beverage
- Laboratory & Medical

Technical Data

This diaphragm seals are used to design hygienic process connections for pressure gauges and to protect pressure gauges from high temperatures and aggressive process fluids.

Hygienic process connections with flush diaphragms ensure efficient cleaning processes and avoid pollutions and developing of bacteria in hygienic production processes.

Diaphragm seals can be mounted to mechanical pressure gauges, switches or transmitters directly or with a flexible capillary. The filling fluid of the measuring system has to be chosen compatible to the application. For hygienic applications a choice of FDA conform filling fluids are available.

Pressure gauges and transmitters assembled with diaphragm seals of the DAXX series can be ordered with 3A approval and marking (option 1985).

Min. pressure ranges	see table on page 4
Max. pressure	25 bar (DANC) 40 bar (others)
Body material	Stainless Steel 1.4404 (AISI 316L)
Diaphragm	Stainless Steel 1.4435 (AISI 316L) Option : Hastelloy C276 (2.4819)
Surface roughness	Wetted parts $Ra \leq 0.8 \mu m$ Option : $Ra \leq 0.4 \mu m$ (welding $Ra \leq 0.8 \mu m$)
Approvals	3A (option 1985) Available for diaphragm seals DAXX assembled with : - Pressure gauges MEX, MIX, MMX, MEP or - Pressure switches TED/YTED including 3A marking of the product
Working temperature	-20 ... 225 °C (depending on the filling fluid)
Filling fluids	LRS1: Vaseline (-15 ... 150 °C, FDA conform) LRS10: Vaseline (-20 ... 225 °C, FDA conform) other filling fluids on request
Gaskets	Not included

3A

- 3A option is not available with cooling element
- Only available with transmission fluid LRS1 or LRS10
- Only available with damping fluid BH1, BH2 or BH10 in the pressure gauge
- Pressure gauges mounted on hygienic seals must have laminated safety glass (0751) or Polycarbonate window (0753).
- Gaskets must be self centering and in accordance with 3A material requirements
- Mounting must be self draining and as short as possible (see drawings)
- Welding to the piping should have a roughness $Ra \leq 0.8 \mu m$

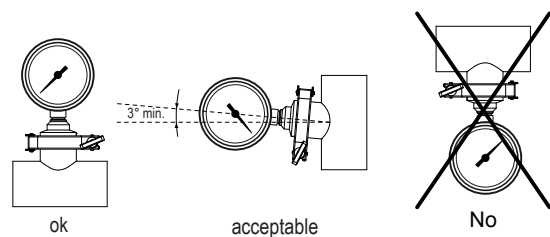

Dimensions - Types of mounting

DANC : Clamp

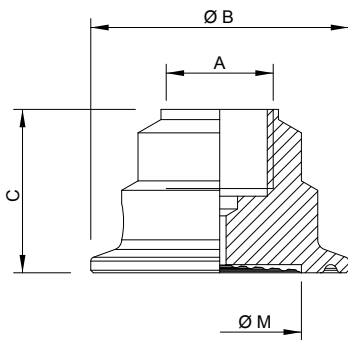

Code	DN	A	Ø B	C	Ø M	Weight kg
DANC07	DN 25 ISO 2852	G1/2 or G1/4	50.5	32 ⁽¹⁾	19	0.20
DANC01	DN 38 ISO 2852	G1/2 or G1/4	50.5	32 ⁽¹⁾	32	0.20
DANC02	DN 51 ISO 2852	G1/2 or G1/4	64	32 ⁽¹⁾	45	0.32
DANC08	DN 25 DIN 32676	G1/2 or G1/4	50.5	32 ⁽¹⁾	19	0.20
DANC10	DN 40 DIN 32676	G1/2 or G1/4	50.5	32 ⁽¹⁾	32	0.20
DANC13	DN 50 DIN 32676	G1/2 or G1/4	64	32 ⁽¹⁾	45	0.32

⁽¹⁾ C=30 with instrument connection A = G 1/4

DAEF : SMS 1147 with thread

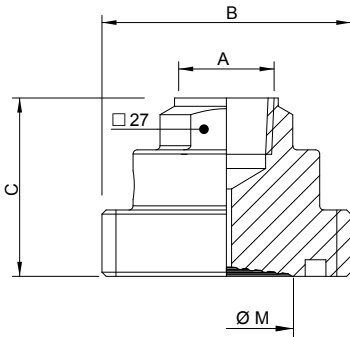

Code	DN	A	B	C	Ø M	Weight kg
DAEF09	DN 25 SMS 1147	G1/2 or G1/4	Rd 40 x 1/6	43 ⁽²⁾	19	0.35
DAEF11	DN 38 SMS 1147	G1/2 or G1/4	Rd 60 x 1/6	43 ⁽²⁾	32	0.52
DAEF14	DN 51 SMS 1147	G1/2 or G1/4	Rd 70 x 1/6	43 ⁽²⁾	45	0.65

⁽²⁾ C=41 with instrument connection A = G 1/4

DAEL : SMS 1147 with nut

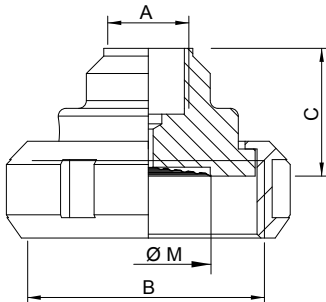

Code	DN	A	B	C	Ø M	Weight kg
DAEL09	DN 25 SMS 1147	G1/2 or G1/4	Rd 40 x 1/6	35 ⁽³⁾	19	0.31
DAEL11	DN 38 SMS 1147	G1/2 or G1/4	Rd 60 x 1/6	33 ⁽³⁾	32	0.55
DAEL14	DN 51 SMS 1147	G1/2 or G1/4	Rd 70 x 1/6	33 ⁽³⁾	45	0.76

⁽³⁾ C=28 with instrument connection A = G 1/4

DADF : DIN 11851 with thread

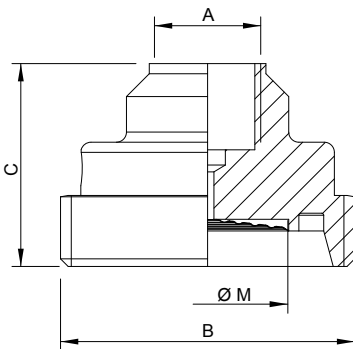

Code	DN	A	B	C	Ø M	Weight kg
DADF06	DN 25 DIN 11851	G1/2 or G1/4	Rd 52 x 1/6	40 ⁽⁴⁾	19	0.31
DADF03	DN 32 DIN 11851	G1/2 or G1/4	Rd 58 x 1/6	40 ⁽⁴⁾	32	0.37
DADF04	DN 40 DIN 11851	G1/2 or G1/4	Rd 65 x 1/6	40 ⁽⁴⁾	32	0.48
DADF05	DN 50 DIN 11851	G1/2 or G1/4	Rd 78 x 1/6	42 ⁽⁴⁾	45	0.61

⁽⁴⁾ C=35 with instrument connection A = G 1/4

Dimensions - Types of mounting

DADL : DIN 11851 with nut

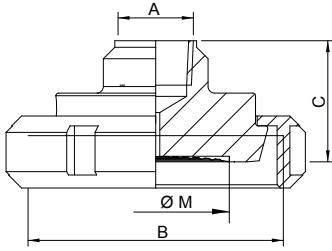

Code	DN	A	B	C	Ø M	Weight kg
DADL06	DN 25 DIN 11851	G1/2 or G1/4	Rd 52 x 1/6	37 ⁽⁵⁾	19	0.43
DADL03	DN 32 DIN 11851	G1/2 or G1/4	Rd 58 x 1/6	37 ⁽⁵⁾	32	0.52
DADL04	DN 40 DIN 11851	G1/2 or G1/4	Rd 65 x 1/6	37 ⁽⁵⁾	32	0.62
DADL05	DN 50 DIN 11851	G1/2 or G1/4	Rd 78 x 1/6	37 ⁽⁵⁾	45	0.90

⁽⁵⁾ C=31 with instrument connection A = G 1/4

DAVA : Varivent®

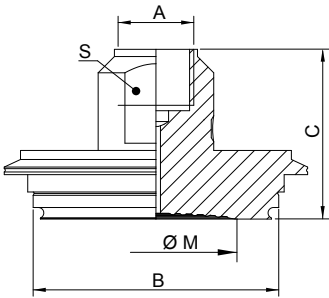

Code	DN	A	B	C	Ø M	Weight kg
DAVA23	DN 10/15	G1/2 or G1/4	31	47 ⁽⁶⁾	19	0.32
DAVA19	DN 25	G1/2 or G1/4	50	47 ⁽⁶⁾	32	0.41
DAVA20	DN 40/125	G1/2 or G1/4	68	47 ⁽⁶⁾	45	0.70

⁽⁶⁾ C=40 with instrument connection A = G 1/4

DAPH : 3A extended clamp

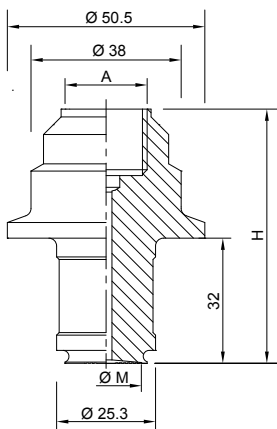

Code	DN	A	H	Ø M	Weight kg
DAPH29	DN 38	G1/2 or G1/4	65 ⁽⁷⁾	19	0.35

⁽⁷⁾ H=61 with instrument connection A = G 1/4

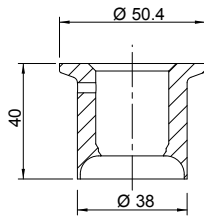

Welding part for pipe
code 11039934

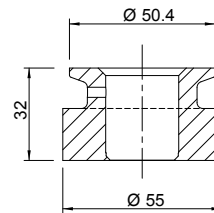

Welding part for tank
code 11043353

Minimum pressure ranges depending on diaphragm diameter Ø M ¹⁾

Ø M ²⁾ (mm)	DN 63		DN 100/150/160	
	gauge	compound	gauge	compound
19	0 ... 4 bar	-1 ... 3 bar	-	-
32	0 ... 2.5 bar	-1 ... 3 bar	0 ... 6 bar	-1 ... 5 bar
45	0 ... 1 bar	-1 ... 1.5 bar	0 ... 1.6 bar	-1 ... 3 bar

¹⁾ Fluid temperature -20 ... 100 °C, ambient temperature -10 ... 50 °C, others on request

²⁾ Ø M according to dimension tables on page 3 and 4

Ordering details DAXx

		XXXX	XX	-	X	X	X	X
Model								
Clamp		DANC						
SMS 1147 with thread		DAEF						
SMS 1147 with nut		DAEL						
DIN 11851 with thread		DADF						
DIN 11851 with nut		DADL						
Varivent®		DAVA						
3A extended clamp		DAPH						
Nominal size								
Clamp DN 25 ISO 2852	DANC¹⁾		07					
Clamp DN 38 ISO 2852	-		01					
Clamp DN 51 ISO 2852	-		02					
Clamp DN 25 DIN 32676	-		08					
Clamp DN 40 DIN 32676	-		10					
Clamp DN 50 DIN 32676	-		13					
DN 25 SMS 1147	DAEF/DAEL²⁾		09					
DN 38 SMS 1147	-		11					
DN 51 SMS 1147	-		14					
DN 25 DIN 11851	DADF/DADL²⁾		06					
DN 32 DIN 11851	-		03					
DN 40 DIN 11851	-		04					
DN 50 DIN 11851	-		05					
Varivent® type B (for DN 10/15)	DAVA³⁾		23					
Varivent® type F (for DN 25)	-		19					
Varivent® type N (for DN 40/125)	-		20					
3A extended clamp	DAPH⁴⁾		29					
Body material								
Stainless Steel 1.4404 (AISI 316L)							2	
Instrument connection								
G 1/2								L
G 1/4								H
Membrane material								
Stainless steel 316L (1.4435)								2
Hastelloy C276 (2.4819)								6
Surface finish								
Ra ≤ 0.8								A
Ra ≤ 0.4 (electropolished)								B

- ¹⁾ option 1985: 3A marked version for sterilization in place (SIP) and cleaning in place (CIP)
- ²⁾ option 1985: 3A marked version for cleaning out of place
- ³⁾ option 1985: 3A marking not available
- ⁴⁾ option 1985: 3A marked version for sterilization in place (SIP) and cleaning in place (CIP)
Installation must be made with one of the welding parts 11039934 or 11043353 (see above)