

# OABR2Ethernet

## Media Converter



OABR2Ethernet is an automotive media converter between OPEN Alliance BroadR-Reach® (OABR) and standard Ethernet 100BASE-T. The device is primarily designed to convert Ethernet signals between a car's ECU on one side and a PC or data logger on the other, but it can also be used for any other application in industrial settings where this conversion is needed.

In addition to the conversion functionality, OABR2Ethernet provides a high-speed CAN transceiver. If there is no activity on the connected CAN bus, the device can optionally be put into sleep mode to reduce power consumption. The sleep timeout is configurable via software.

Basic configuration is realised with DIP switches, and LEDs provide information about the current status of the media converter and the connected interfaces. The firmware of the device can be updated via USB bootloader.

### Features

- Converts from OABR to Ethernet and vice versa
- Sleep/wake up via CAN transceiver
- Configuration via DIP switches
- Firmware update via USB bootloader
- Rugged aluminium enclosure

### Specifications

- Dimensions (H x W x D)  
21 x 56 x 104 mm
- Data rate  
100 Mbit/s guaranteed
- Temperature range  
-40 °C to +65 °C
- Supply voltage  
5 V to 28 V
- Current consumption  
max. 150 mA
- Current consumption (standby)  
max. 32 mA

### Delivery Contents

- OABR2Ethernet media converter
- Cable set (optional)
- Software
- Manual

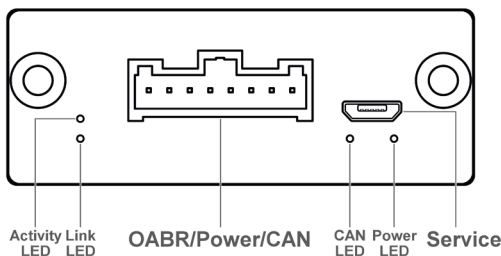

Front view

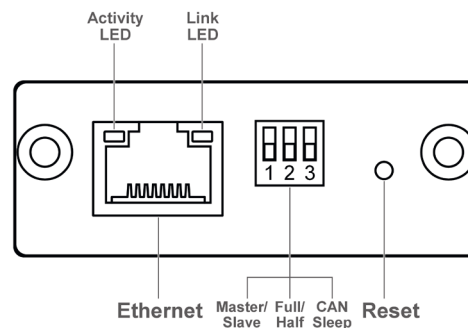

Back view

X2E Entwicklungszentrum  
Jahnstr. 2b  
76870 Kandell, Germany

Phone: +49 7275 9143-200  
Email: [xoraya@x2e.de](mailto:xoraya@x2e.de)  
Web: [www.x2e.de](http://www.x2e.de)

# OABR2Ethernet

## Media Converter

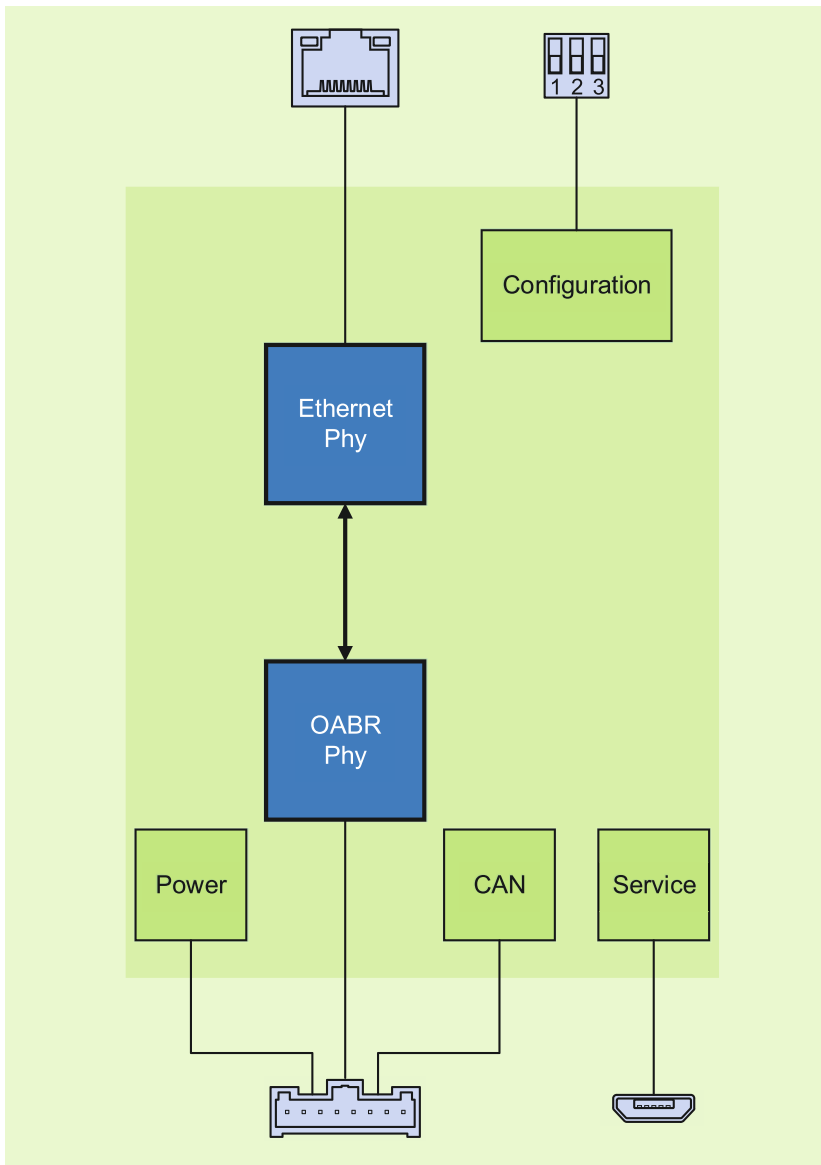

Block diagram

### Connectors

- 8-pin connector for OABR, power and CAN
- RJ45 for Ethernet
- Micro USB as a service interface

### DIP Switches

- Master or slave mode
- Full or half out mode
- CAN sleep mode activation

### LEDs

- OABR link and activity
- Ethernet link and activity
- CAN activity
- Power

Errors and omissions excepted.



2.1.02.019