

# FG-SP5R\_AP

## 5" CEILING MOUNT LOUDSPEAKER WITH FIRE DOME



### PRODUCT OVERVIEW

Thank you for purchasing **FG-SP5R\_AP**. Widely used in commercial buildings and public facilities, Fireguard product is manufactured in strict accordance with ISO 9001 standards. Please read this manual before installation and follow all instructions.

**FG-SP5R\_AP** Voice Alarm ceiling loudspeaker is designed for flush in suspended ceiling and ideal for even sound distribution. The loudspeaker has a built-in protection to ensure that, in the event of a fire, damage to the loudspeaker does not result in failure of the loudspeaker circuit which is connected. In this way, system integrity is maintained and ensuring loudspeakers connected in the same circuit in other areas can still be used to inform people of the situation.

The loudspeaker can be easily installed by using the mounting spring attached. Likewise, the fire dome is mounted in the speaker openings on the ceiling panel by using the sliding brackets and the wing nuts as first-fix. **FG-SP5R\_AP** is equipped with ceramic terminal blocks, thermal fuse and heat-resistant, hightemperature wiring to comply with EN54 part 24.



### Features

- Excellent sound reproduction
- Fire resistant cover with fire dome
- EN54-24 certified

### Safety Notice

- After installing the speaker it is crucial to check carefully to ensure that the unit is working properly
- Proper functioning cannot be guaranteed if the speakers are not installed correctly in accordance with the instruction.
- Please observe the relevant national regulations and guideline.

**CE** 0359  
19  
0359-CPR-XXXXX

### Technical Specification

Model	FG-SP5R
Speaker	5"
Rated power	6 W
Impedance (Ω)	1.7k / 3.3k / 6.7k / 13k
Power taps @ 70V	3 W / 1.5 W / 0.75 W / 0.375 W
Power taps @ 100V	6 W / 3 W / 1.5 W / 0.75 W
SPL (1W/1m, 100Hz-10k Hz)	91 dB
SPL (1W/4m, 100Hz-10k Hz)	79 dB
SPL (6W/4m, 100Hz-10k Hz)	88 dB
Frequency response (-10dB)	180 Hz - 20k Hz
Dimensions	Ø 181 mm × 129 mm
Weight	1.29 kg
Material	Steel
Front grill color	White (RAL9003)
Dome color	Red (RAL3000)
Installation opening size	Ø 155 mm
Fire dome mounting method	Sliding plate with wing nut
Loudspeaker mounting method	Spring clip grill
Ceramic terminal	Yes (in fire dome)
Thermal Fuse	150°

- \* The reference axis is perpendicular to the centre point of the front grill
- \* The reference plane is perpendicular to the centre of the reference axis
- \* The horizontal plane is perpendicular to the centre of the reference plane
- \* The spec/data was measured using a standard baffle mounting in a anechoic chamber as described in EN54-24

MODEL	DESCRIPTION
FG-SP5R_AP	5" Ceiling Loudspeaker

# FREQUENCY RESPONSE AT dBspl(20uPa)@4m, 1W/41.2V INPUT,1/3 OCT SMOOTHING

With transformer:  
100V/70V line

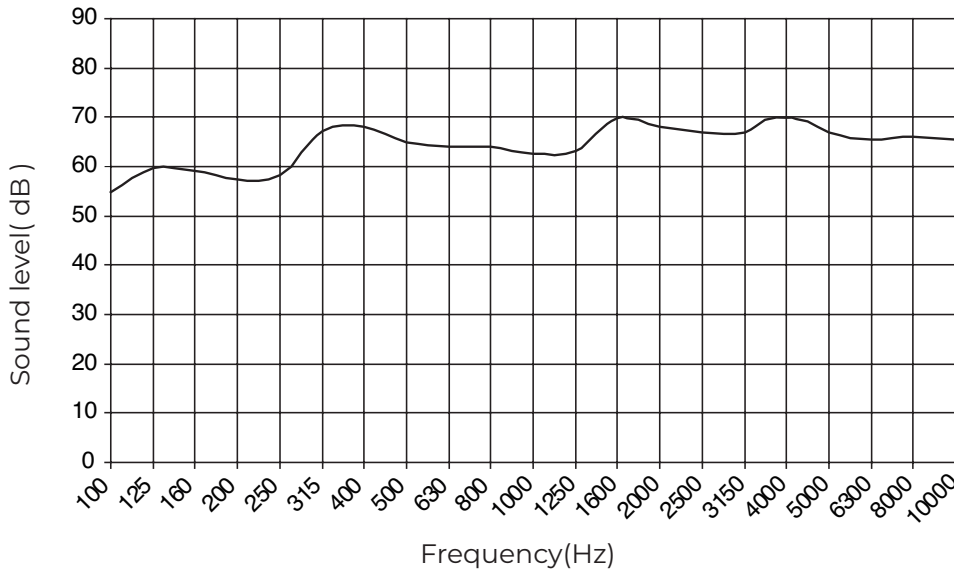

	Red wire plus tapping				Black
100V	0.75W	1.5W	3W	6W	Com
70V	0.375W	0.75W	1.5W	3W	Com
IMP(Ω)	13K	6.7K	3.3K	1.7K	

## Dispersion angles

		Horizontal	Vertical
1 oct. pink noise	500 Hz	187°	174°
1 oct. pink noise	1K Hz	173°	174°
1 oct. pink noise	2K Hz	151°	152°
1 oct. pink noise	4K Hz	59°	58°

## CIRCUIT DIAGRAM

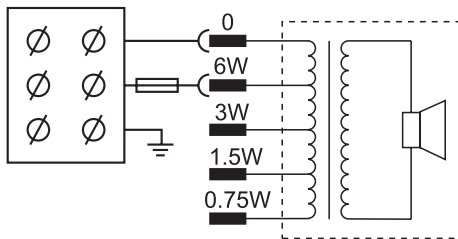

## THREE-VIEW DIAGRAM

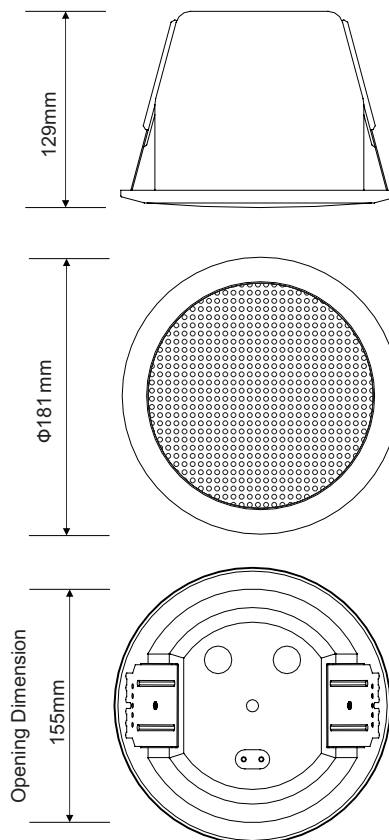

## INSTALLATION

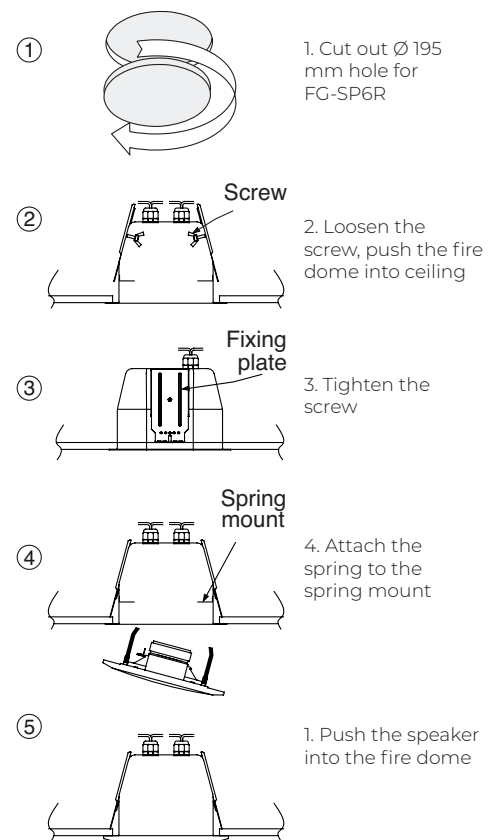

## POLAR DIAGRAM

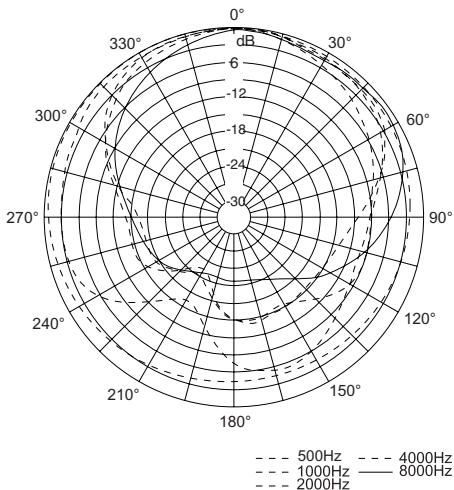

## FIREGUARD GLOBAL LTD.

Tel: 00-44-8450751042  
 Fax: 00-44-8459751043  
 Email: Info@Fireguard-Uk.com  
 www.fireguard-Uk.com



Unit 11 · Chancel Industrial Estate · Newhall Street  
 Willenhall · WV13 1NX · United Kingdom



FS546607