

DMFC36 Driver Module



User Manual



X20092

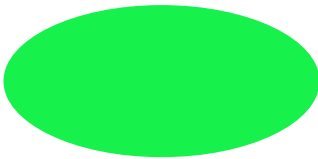

KEY FEATURES

- Standard DIN Rail Mounting.
- Selectable modes of control: Phase Angle or Burst Fire (Single-Cycle/Dual-Cycle & adjustable STD Burst Firing).
- On Board Indication of Power, Burst-Rates & Fault conditions.
- Inhibit input.
- Wide Range of Control Options (0-5V, 0-10V, 1-5V, 2-10V, 0-20mA, 4-20mA, Manual Potentiometer).
- On board protection fuse.
- Isolated Pulse Transformer outputs.
- Soft Start.
- Auto Phase-Rotation detection.

INTRODUCTION

The DMFC36 driver module has been designed to offer both phase angle & burst fire control of thyristor controllers driving Resistive loads. The Single-Cycle & Dual-Cycle options offer the fastest burst rates possible, providing very accurate control and minimising Harmonic distortion & Flicker within the system. In addition, the standard variable burst rate, adjustable from 1 to 30 seconds, is also available. The DMFC36 software also includes auto phase rotation.

Designed to be used in conjunction with a thyristor assembly or supplied on one of our complete thyristor controllers, the DMFC36 offers a highly versatile and cost effective solution in a wide variety of applications.

The DMFC36 is commonly used in three phase applications with both 3-Wire and 4-Wire load configurations (including Closed-Delta, Floating-Star & Star to Neutral), where all three limbs are controlled (fully controlled circuit).

The DMFC36, operating in Burst-Fire mode, is also commonly used in three phase, 3-Wire load configurations (including Closed-Delta & Floating-Star), where only two limbs are controlled (2/3rds controlled circuit).

For ease of mounting & for protection purposes, the controller comes in a DIN Rail Enclosure.

TECHNICAL SPECIFICATIONS

Std Supply Voltage	420/460 VAC selectable via LINK J1 (other supply voltages available)
Supply Frequency	50/60 Hz
Auxiliary Supply Voltage	4V AC/DC (500mA minimum)
Power Consumption	VA
Internal Fusing	1 Amp 32mm fuse
Protection Rating	IP20
Operating Temp Range	0-65°C
Input Signal Options	0-5VDC, 0-10VDC, 1-5VDC, 2-10VDC, 0-20mA, 4-20mA, Manual Potentiometer
Output Specification	Pulse transformer picket-fence 25kHz pulse output. Initial pulse 500mA & Sustaining pulses of 250mA
Output Isolation	3.5 KV
Soft Start (Ramp Speed)	0-30 seconds (adjustable)
STD Burst-Fire Cycle Time	Minimum 1s to Maximum 30s variable. Selectable via switch SW1
Rapid Burst-Fire Cycle Time	Single-Cycle/Dual-Cycle variable time base, selectable via switch SW1
Green LED indicator	Power ON, indicating when 5 VDC is present
Red LED indicator	LED ON continuously indicates phase loss between K2 phase 1 & K2 phase 2. LED slow flashing indicates no current control signal (4-20mA) LED fast flashing indicates incompatible 2-Leg control & 4-Wire load selected
Yellow LED indicator	Burst-Rate indicator, mimics the output burst-rate
Safety Standards	Complies with European Low Voltage Directive & major international standards

TERMINALS & CONNECTIONS

Terminal	Function	Notes
9-way terminal block reading from Left-Right		
1	5V DC output (50mA max.)	This supply used to feed 5VDC to the clockwise end of the manual control potentiometer or auxiliary circuit.
2	+VE voltage control signal input	+ve control signal input from Temperature Controller or connect to wiper of a manual control potentiometer
3	Ground / 0V -VE voltage control signal input	-VE control signal input from Temperature Controller or connect to the counter clockwise end of the manual control potentiometer.
4	+VE Current signal input	+VE Current signal input, 0-20mA or 4-20mA
5	Ground / 0V	-VE Current signal input, 0-20mA or 4-20mA
6	INHIBIT	CLOSE Contacts to DISABLE (shut down) controller
7	INHIBIT	OPEN Contacts to ENABLE the controller
8	(Common 0V Line)	External -VE 24VDC supply only required if supply to L1 and L2 are not being used
9	+24V AC or DC input	External +VE 24VDC supply only required if supply to L1 and L2 are not being used
Additional Connections		
HI/LO	High / Low Jumper Link	Select High or Low supply voltage range
L1 & L2	AC Supply input use any 2 phases or phase and Neutral.	AC supply only required if 24V DC supply to terminals 8 and 9 are not being used
G1 & K1 G2 & K2	Output connections to Thyristor's	Timing reference inputs from K2 of Phase 1 and K2 of Phase 2 are taken from here

SWITCH SETTINGS

SW1 Settings ON=1 (UP) OFF=0 (DOWN)	
SW1 6 way DIP switch	Notes
Brown Switch ON	Phase Angle Enabled
Brown Switch OFF	Phase Angle Disabled
Red Switch ON	Burst Fire Enabled
Red Switch OFF	Burst Fire Disabled
Orange Switch ON	VR1 Clockwise : Dual Cycle VR1 Anti-Clockwise : Single Cycle
Orange Switch OFF	Variable Burst Rate set by VR1 TIME BASE 1 to 30 seconds
Yellow Switch ON	Offset ON
Yellow Switch OFF	Offset OFF
Green Switch ON	When this switch is ON it sets an offset of 20%, this mode is used for control signals which do not start from 0, such as 1-5V, 2-10V and 4-20mA.
Green Switch OFF	In this position there is no offset, this mode is used for control signals starting from 0, such as 0-5V, 0-10V and 0-20mA.
Blue Switch ON	The controller is set for a 3-Wire configured load (Closed-Delta or Floating-Star), where there is no Neutral connection.
Blue Switch OFF	The controller is set for 4-Wire configured load (Star to Neutral), where there is a Neutral connection to the Star Point. Note in this position the Green switch must be switched OFF
Purple Switch ON	The controller is set up to control 2 limbs L1 and L2 of a three phase load L3 is connected directly to the load, Neutral must not be connected in this configuration
Purple Switch OFF	The controller is set up to control all 3 limbs of a three phase load the star point maybe floating or connected to Neutral
Grey Switch ON	The controller is set for 0-10V DC control signals
Grey Switch OFF	The controller is set for 0-5V DC control signals and manual control uses a 5K Potentiometer

WIRING (THYRISTOR CONNECTIONS)

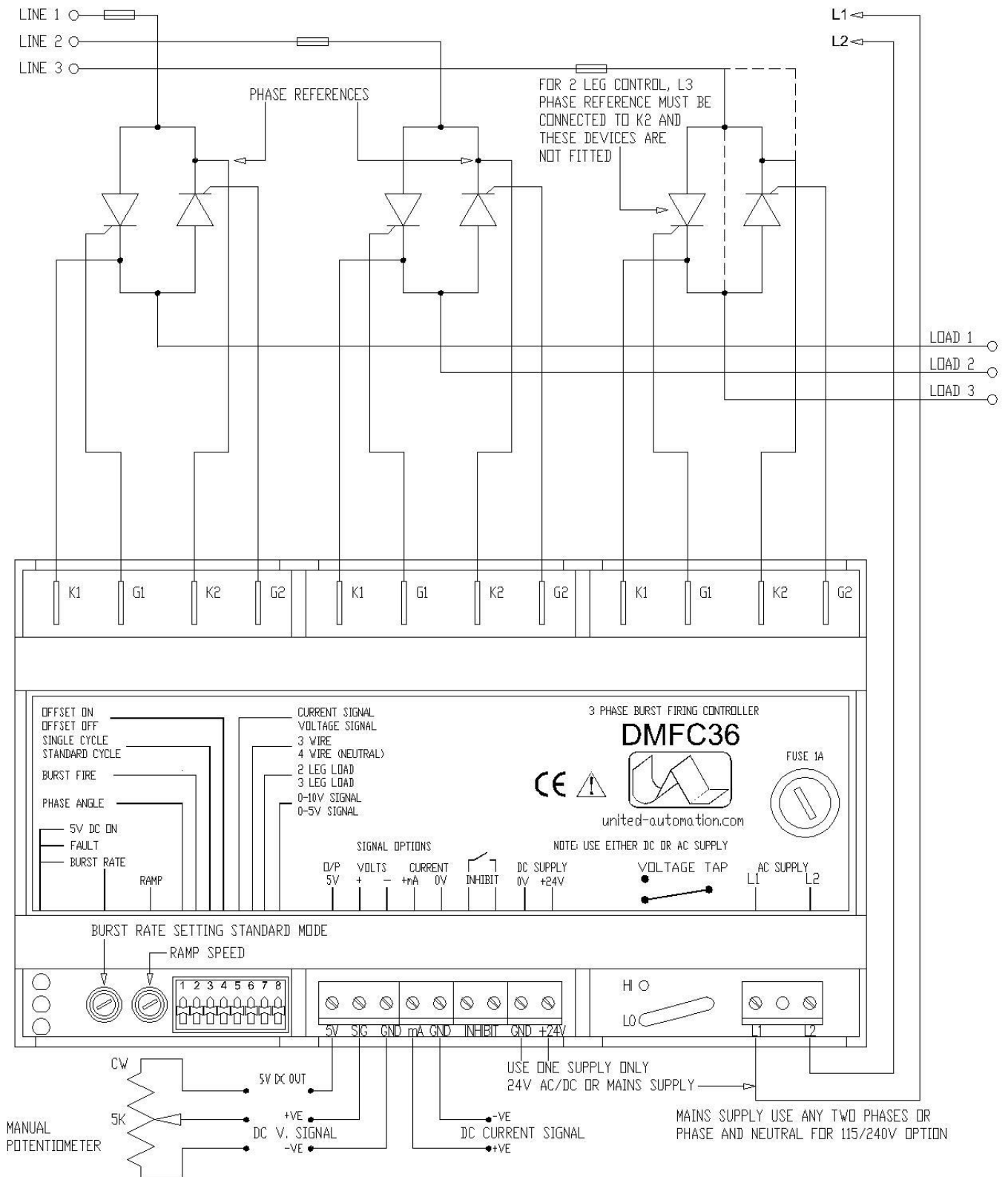

NOTE: For 2-leg (2/3rd) control, L3 phase reference must be connected to PHASE-3, K2.

APPLICATION CIRCUITS

Typical 3-Phase, 3-Wire, 4-Wire & 6-Wire Load configurations (all three phases switched).

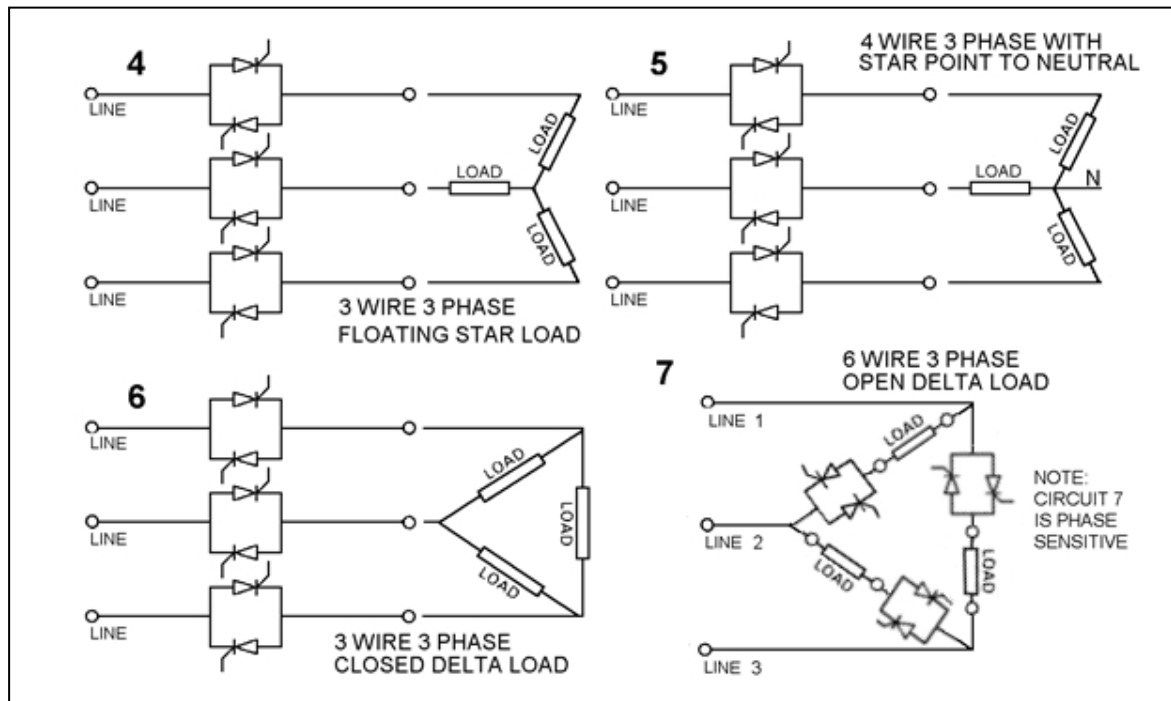

Typical 3-Phase, 3-Wire Load configurations (only two of three phases switched) Burst-Fire mode only.

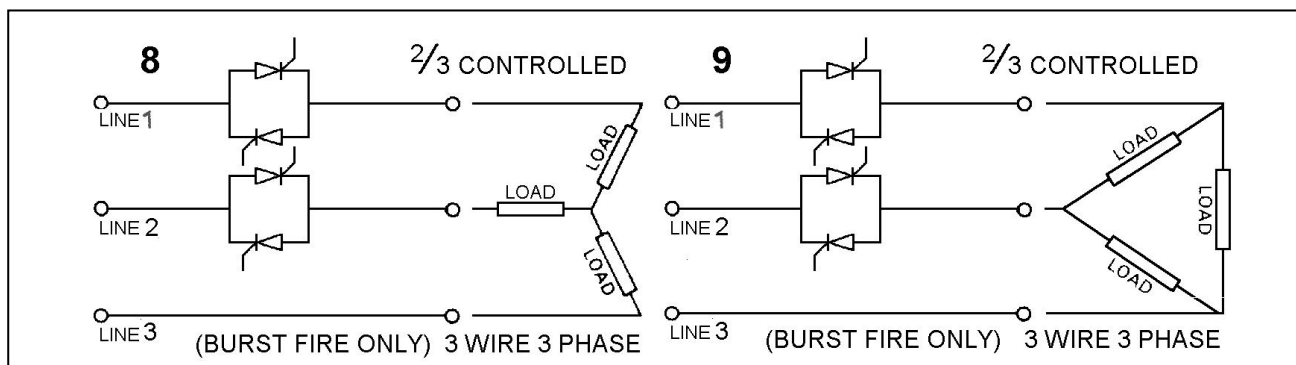

TERMINAL CONNECTIONS

Connections are made to the above terminals which will accept wires up to 1.5mm² cross section. The use of screened cable is not usually necessary for control signal wiring within a panel.

Normal precautions should be taken to keep signal wiring away from power cables, in particular avoid running signal cables parallel to power cables in the same trunking. See ITA datasheet for more information.

PHASE REFERENCE

The phase references, for the zero voltage detection circuit is taken from both of the K2 connections of PHASE 1 and PHASE 2, this phase reference is provided by the Cathode connections of the thyristor modules so the correct orientation of the thyristor modules is required see the schematic diagram. If the line supply to either of these phases is not present the Red LED will be on continuously and the output drive will be inhibited until the supply to these phases is reinstated.

WAVEFORMS (TYPICAL FOR SINGLE-CYCLE & DUAL-CYCLE SWITCHING)

The following diagrams show representations of voltage waveforms for Burst-Fire (Single-Cycle & Dual-Cycle switching) operation. The heavily outlined portion of the sinusoidal train indicates when the thyristors are switched on, and the lighter portion indicates when they are off. The waveforms show zero voltage (and thus current) switch on, and zero current switch off.

A more comprehensive set of waveforms and Harmonics information is available in a separate appendix document Ref : X10789.

Single cycle fast burst 50% setting 2 leg control

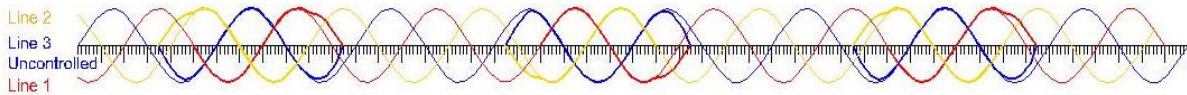

Dual cycle fast burst 50% setting 2 leg control

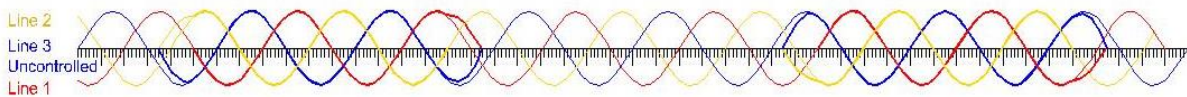

Single cycle fast burst 50% setting 3 leg control 3 wire load

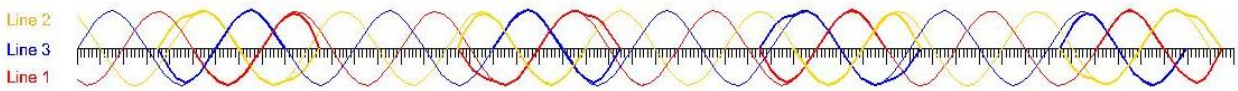

Single cycle fast burst 50% setting 3 leg control 4 wire load

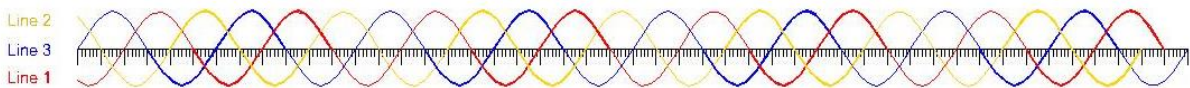

EMC Standards Complies with the European EMC Directive for operation in an industrial environment

The following standards have been applied in whole or in part in the design of this controller; EN61010-1, EN61000-6-2, EN 50 081 part 2.

DIMENSIONS

Overall dimensions are as shown.

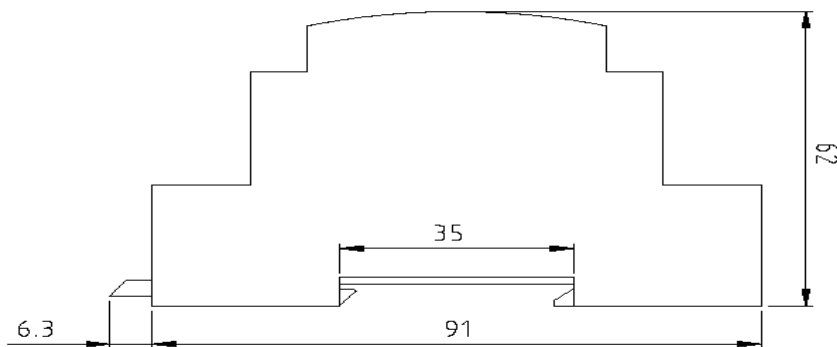
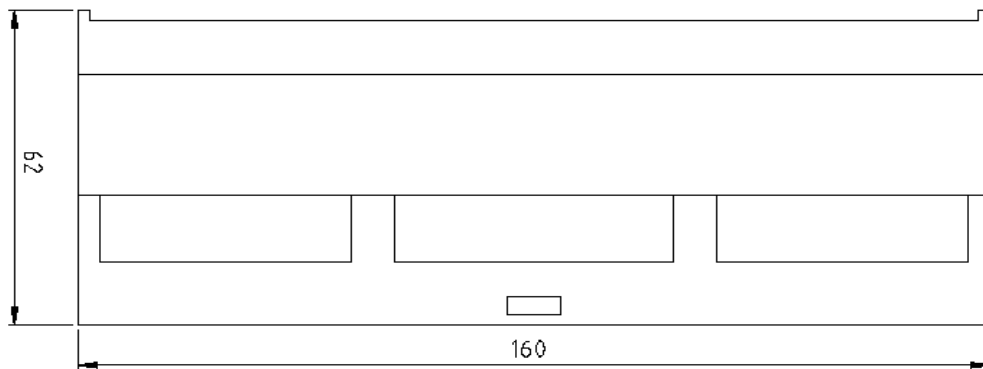

FIXING

Unit should be installed on TS35 DIN rail via DIN clip on base of control module.

WEIGHT

The unit DMFC36 complete module (as photo) has a typical weight =<500g.

RECOMMENDATION & SAFETY REQUIREMENTS

SUPPORTING DATASHEETS FOR PRODUCTS AND APPLICATIONS

Other documents, which may be appropriate for your applications, are available on request.

<u>CODE</u>	<u>IDENTITY</u>	<u>DESCRIPTION</u>
X10772	3-RFI	Filter recommendation: Addressing the EMC directive.
X10213	ITA	Interaction: Uses for phase angle and for burst fire control.
X10255	SRA	Safety requirements: Addressing the Low Voltage Directive (LVD) including, Thermal data/cooling, Live parts warning Earth requirements and Fusing recommendations.
X10322	APC	Application Circuits.
X10789	WAV	Single or Dual Cycle Waveforms & Harmonics Data.

NOTES:

It is recommended that installation and maintenance of this equipment should be carried out by suitably qualified personnel, with reference to the current edition of the I.E.T. Wiring Regulations BS7671. The regulations contain important requirements regarding the safe installation of electrical equipment.

Additional 'failsafe circuitry' e.g. line circuit breakers, high-speed SCR-type and/or general fusing and thermal trips, should be used as part of the main installation requirements.



Not for general waste

ORDER CODES

Basic Instrument	Supply	UAL Order Code
DMFC36	420/460VAC 50 Hz and 24V AC/DC	A34571
DMFC36	480VAC 50Hz	A34572
DMFC36	380/500VAC 24V AC/DC input	A34573

PRODUCT FUNCTION & APPLICATION

The DMFC36 offers Phase Angle, Burst fire or Single-Cycle/Dual-Cycle (Rapid Burst Firing) control where minimum fluctuation in heater element temperature is required. This type of Rapid Burst Fire is useful if a system has a high impedance supply as a result of long power leads or if the system is powered by a generator set. Normally this can result in the supply being subject to mains dips, but this option minimises the 'Flicker' effect on the mains supply. Another benefit of using this type of control is that you avoid high 'Harmonic Distortion' normally associated with phase angle control, typically down to levels of below 4%.

The DMFC36 can be started in phase angle mode and switch to burst mode when the control signal ramps up to the set point. It will stay in the burst mode even if the signal drops below the set point. It will restart in phase angle mode when the unit is switched off or reset.

A typical application for this module would be for a three phase thyristor controller for connection to a heater load to regulate its power.
