

BG2E – Universal Gate Drive Prototype Board

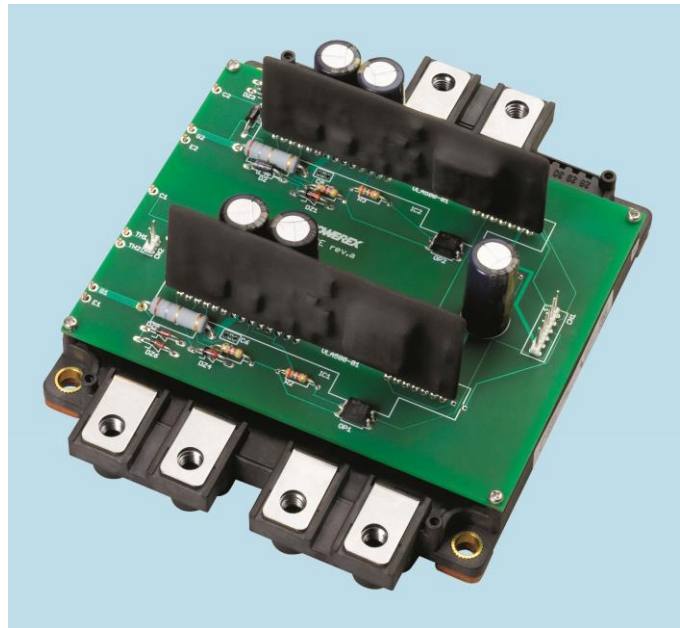
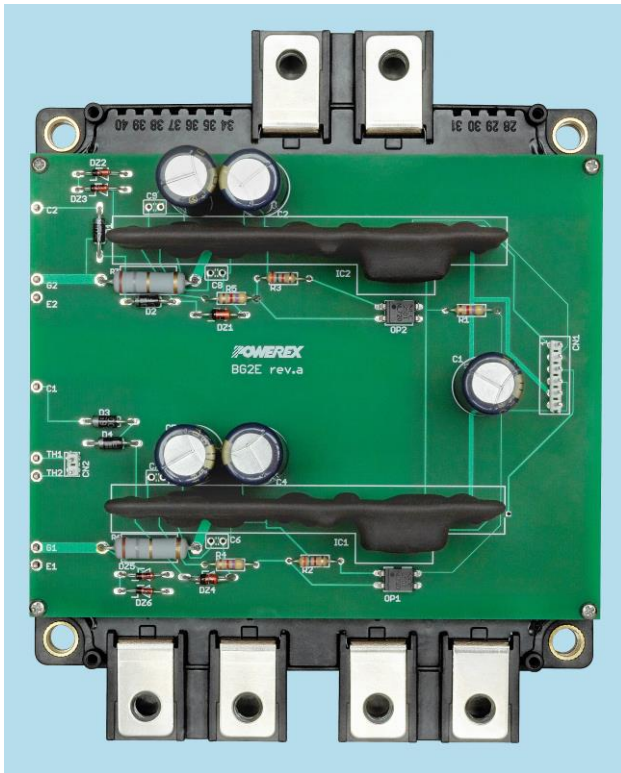

Description: BG2E is a fully isolated two channel gate drive circuit designed for use with dual NX-L series IGBT modules, designed to sit directly on top of a dual NX-L series IGBT module, allowing a simple mounting process. The BG2E utilizes Powerex VLA500-01 hybrid gate drivers to provide efficient switching of NX-L modules rated up to 1000A. The hybrid gate drivers also provide protection against unexpected short circuit conditions using desaturation detection. The VLA500-01 hybrid gate driver has an integrated DC-to-DC converter with 2500VRMS isolation to provide isolated gate drive power. Control signals are isolated using high speed opto-couplers with 15kV/ μ s common mode noise immunity. The BG2E provides an isolated fault feedback signal if a short circuit condition is detected.

Features:

- Up to 12A Peak Output Current
- 2500VRMS isolation for control power and signals
- Standard AMP MTA .100" Connectors
- Operates from a single 15 VDC supply
- Wide output voltage swing +15V/-8V
- Compact Size 4" x 2.1" (122mm x 99mm)

Applications:

BG2E is designed for use with Powerex NX-L series IGBT modules.

- **Uses VLA500 series hybrid gate drivers**

Ordering Information: **BG2E-NXL** is a kit that includes a PCB with two VLA500-01 gate drivers
(For use with NX-L Series IGBT modules)

BG2E-NXLK is a kit that includes a PCB with two VLA500K-01R gate drivers
(For use with 1700V NX-L Series IGBT modules)

Circuit Explanation: The BG2E is a basic two channel gate driver designed around the recommended application circuit for the Powerex VLA500 series hybrid gate driver. A functional block diagram of the VLA500 hybrid gate driver is shown for reference in Figure 1. The VLA500 series uses a standard high speed open collector type opto-coupler with a maximum turn-off propagation delay of 1.3us. This makes it suitable for industrial applications with operating frequencies of up to 20 kHz. The VLA500 can be used with most Powerex IGBT modules. For additional detailed information on the operation of the hybrid gate drivers please see the individual datasheets.

A complete schematic and component selection guide for the BG2E is shown in Figure 2. The board will normally be operated with two input voltage sources. A 5V logic source (+V_L) provides drive for the high-speed opto-couplers inside the hybrid gate drivers and pull-up voltage for the fault signal isolation optos OP1 and OP2. A 15V power supply (+V_S) provides power for the gate driver and is connected to the primary side of the hybrid gate driver's built in DC-to-DC converter at Pins 1, 2 and 3, 4 of the VLA500. The +15V source is decoupled with the low impedance electrolytic capacitor C1. In the BG2E circuit a 1000uF capacitor was selected for C1 so that the same capacitor could be used for C1, C2, C3, C4 and C5. In most applications this will be much larger than necessary to

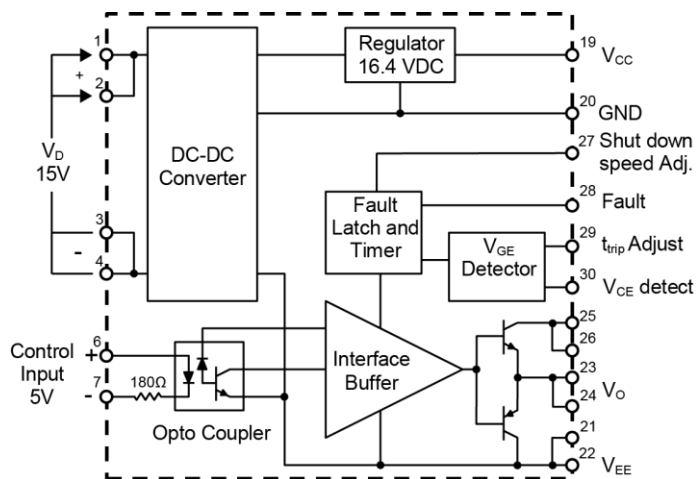
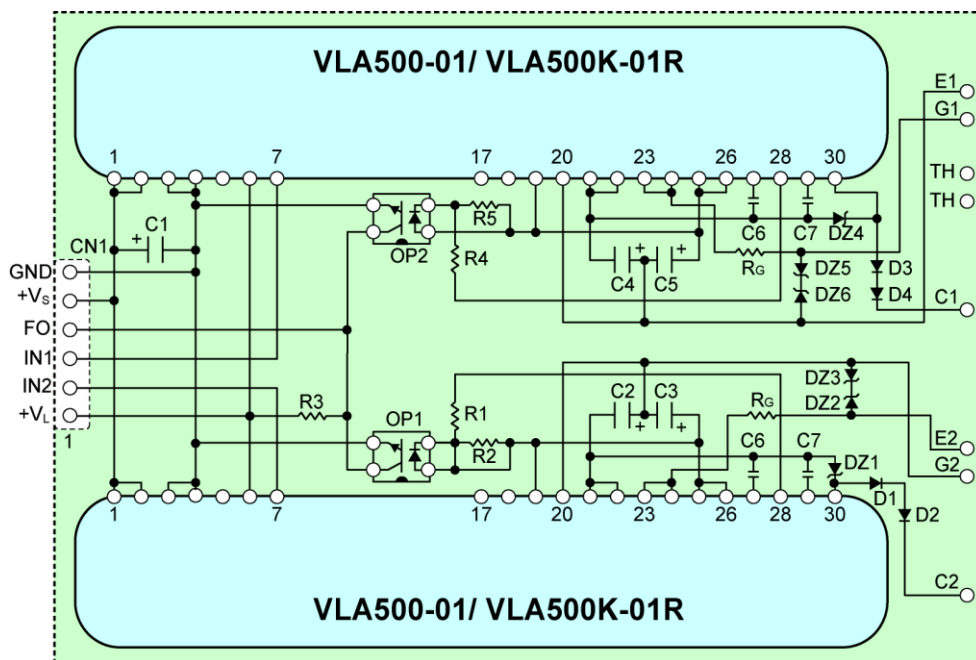

Figure 1: VLA500 Series Block Diagram



Component Selection:

| Designation | Typical Value | Description | Example: Mfg. /PN |
|--------------------|---------------|---|-----------------------|
| D1, D2, D3, D4 | 0.5 A, 1000V | V _{CE} detection diode – ultra fast recovery | ON Semi/MUR1100E DZ2, |
| DZ3, DZ5, DZ6 | 16V, 1W | Gate Voltage Surge Protection | 1N4745 |
| DZ1, DZ4 | 30V, 1W | Detect input pin surge voltage protection | 1N4751 |
| C1, C2, C3, C4, C5 | 1000 μF, 35V | Power supply filter – Electrolytic, low Impedance | Panasonic EEU-FC1V102 |
| C6 | 0-1000 pF | Adj. soft shutdown – Multilayer ceramic or film** | EPCOS B37979----- |
| C7 | 0-200 pF | Adj. trip time - Multilayer ceramic or film** | EPCOS B37979----- |
| R2, R3 | 3.3kΩ, 0.25W | Fault signal noise suppression resistor | |
| R4, R5 | 4.7kΩ, 0.25W | Fault sink current limiting resistor | |
| R1 | 4.7kΩ, 0.25W | Fault feedback pull-up resistor | |
| OP1, OP2 | NEC PS2501 | Opto-coupler for fault signal isolation | NEC/ PS2501 |
| CN1 | MTA .100" | Input connector | AMP 640456-6 |

Recommended mating connector AMP CST-100 Housing P/N 770602-6 with crimp contact 770666-2.
 ** C6, C7 are only required in certain special applications. Please see VLA500/VLA502 application notes for details.

Figure 2: BG2E Schematic and Component Selection Guide

support the drivers ripple current. Typical applications will be able to use 100uF or less depending on the load current and the distance from the main 15V supply filter capacitors. The hybrid's built in DC-to-DC converter provides isolated gate drive power which consists of +16.4V (V_{CC}) at Pin 19 and -9V (V_{EE}) at Pins 21 and 22. These supplies share a common ground at Pin 20. The gate drive power supplies are decoupled using the low impedance electrolytic capacitors C2, C3, C4 and C5. It is very important that these capacitors have low enough impedance and sufficient ripple current capability to provide the required high current gate drive pulses. The 1000uF capacitors used on the BG2E are sized to supply 12A gate pulses at a 20 kHz rate. If the application is operating at lower frequency or lower peak current it may be possible to reduce the size of these capacitors. Consult the hybrid gate driver individual datasheets for details on selecting the decoupling capacitors.

The V_{EE} and V_{CC} supplies are connected to the driver's output stage to produce gate drive at Pins 23 and 24. The gate drive current is adjusted by selecting the appropriate series gate resistance (R_G). R_G will normally be adjusted to provide suitable drive for the module being used. For more information see Powerex IGBT module application notes. Protection against gate voltage surges is provided by DZ2, DZ3, DZ5, and DZ6. These zener diodes also help to control short circuit currents by shunting miller current away from the gate.

Short circuit protection is provided by means of desaturation detection. For details on the operation of this circuit consult the VLA500/VLA502 datasheets. The collector voltage of each IGBT is detected through the series connected high voltage blocking diodes D1, D2 and D3, D4. The combined blocking voltage of the series connected diodes must be equal to or greater than the V_{CES} rating of the IGBT. For applications using lower voltage devices it may be possible to use a single detection diode. DZ1 and DZ4 protect the gate driver's detect input (Pin 30) from voltage surges during reverse recovery of the high voltage blocking diodes. The CS and CT capacitors are used to adjust the drivers protection circuit trip time and slow shut-down speed. The driver's default settings are sufficient for many applications and therefore these capacitors can be omitted. For details on the use of CT and CS consult the VLA500/VLA502 datasheets.

If the gate driver's short circuit protection is activated it immediately shuts down the gate drive and pulls Pin 28 low to indicate a fault. Current flows from V_{CC} (Pin 19) through the LED in fault isolation opto (OP1, OP2) to Pin 28. The transistor in the fault isolation opto turns on and pulls the fault signal line (FO) at Pin 4 of CN1 low. This opto-isolated signal can now be used by the controller to detect the fault condition.

Interface Circuit Requirements: A typical input circuit for the BG2E is shown in Figure 3. A single +15V control power supply ($+V_s$) is connected to Pin 5 of CN1 with its ground at Pin 6. This supply provides all of the gate drive power for both channels via the hybrid gate drivers' built-in DC-to-DC converters. The current drawn from the 15V supply will vary from less than 200mA to more than 1A depending on the switching frequency and size of IGBT being driven. Consult the hybrid gate driver individual datasheets for details on determining the required supply current. A 5V logic supply is connected at Pin 1 of CN1 and shares the same common ground at Pin 6 of CN1 as the 15V control supply. The 5V supply is directly connected to Pin 6 of the hybrid gate driver which is internally connected to the anode of the LED in the high speed opto-coupler. The 5V supply is also used to pull the output side of the fault isolation opto-couplers high.

The control signal interface is designed for use with standard 5V CMOS logic. The control input signals at Pins 2 and 3 of connector CN1 are used to turn the IGBTs on and off. These signals are active low which means that the gate driver output will be high (IGBT on) when they are pulled low. These control pins are connected directly to Pin 7 of the hybrid gate driver which is connected internally through a limiting resistor to the cathode of the LED in the high speed opto-coupler (see Figure 1). When the control signal is pulled low current flows from the 5V logic supply through the LED to turn the gate driver's output on. The control pins must be pulled low with a buffer that is

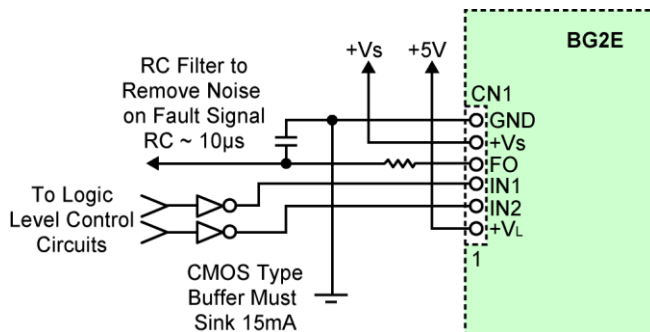

Figure 3: BG2E External Wiring Diagram

capable of sinking 15mA in order to turn on the high speed opto-coupler inside the VLA500. A CMOS buffer that actively pulls its output high is recommended for maintaining good common mode noise immunity in the off state. Open collector type drive is not recommended.

The fault signal line on Pin 4 of CN1 is active low which means that a fault condition will be indicated by a low level signal. During normal operation Pin 4 is pulled high to the +5V supply (+V_L) by the 4.7K resistor R3. If either of the VLA500 gate drivers detects a short-circuit condition the fault isolation optos (OP1, OP2) turn on and pull Pin 4 of CN1 low. When a fault is detected the hybrid gate drivers disable the output and produce a fault signal for a minimum of 1ms. Any signal on the fault line that is significantly shorter than 1ms cannot be a legitimate fault so it should be ignored. Therefore, for a robust noise immune design, it is recommended that an RC filter with a time constant of approximately 10us be added between Pin 4 and the controller as shown in Figure 3.

Thermistor Connection: The case temperature of the NX series device can be monitored by reading the resistance value of the built in NTC Thermistor. This is accessed on the BG2E board at CN2 Pins 1 and 2. The relationship between the resistance and the temperature measurement is given by the B constant as shown in Equation 1. The B constant can be found on the datasheet for the IGBT module. Solving for temperature of any given point T_x, with a reference temperature of 25°C we can come up with Equation 2. Equation 2 is very useful because R₂₅, the resistance with a case temperature of 25°C, can be easily measured. It is important to note that this equation is valid for temperatures measured in Kelvin (K) in which case T₂₅ = 25+273 = 298K.

$$EQ.1: B = (\ln R_1 - \ln R_2) / (1/T_1 - 1/T_2)$$

$$EQ.2: T_x = B / (\ln R_x - \ln R_{25}) + T_{25}$$

Printed Circuit Layout: Figure 4a through 4c shows the layout of the BG2E two channel gate driver board. The 122mm x99mm circuit board with only 28 components clearly demonstrates the advantage of using the VLA500 hybrid gate drivers. One important feature is the use of three ground plane islands for the regions of the PCB having high voltage differences. Two of the islands are tied to the emitter/circuit common (Pin 20) of each output channel. The third island is connected to logic interface common at Pin 6 of CN1. This layout prevents undesirable coupling of noise between the control side and the gate drive channels.

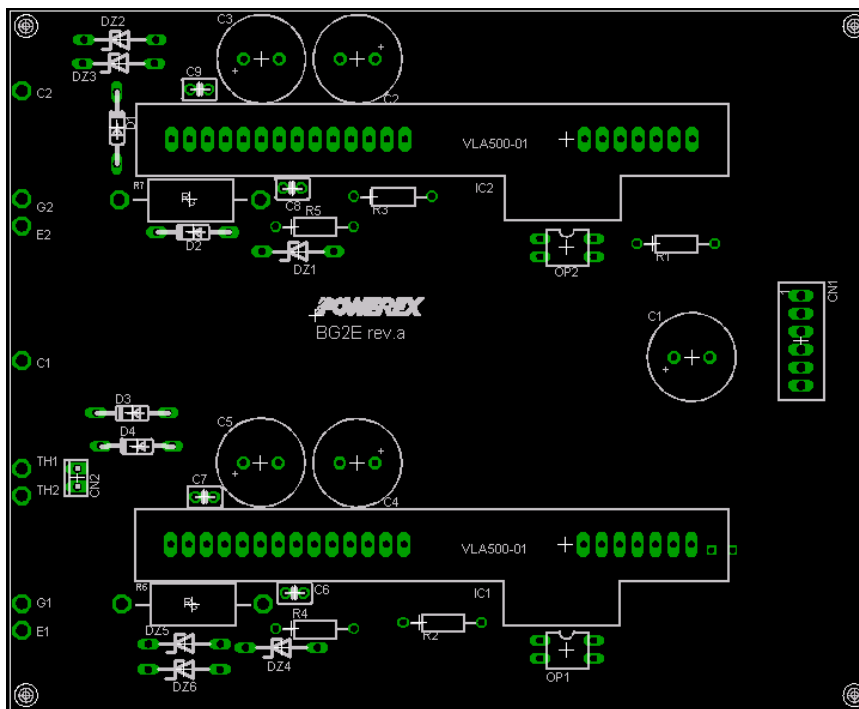

Figure 4a: Component Legend

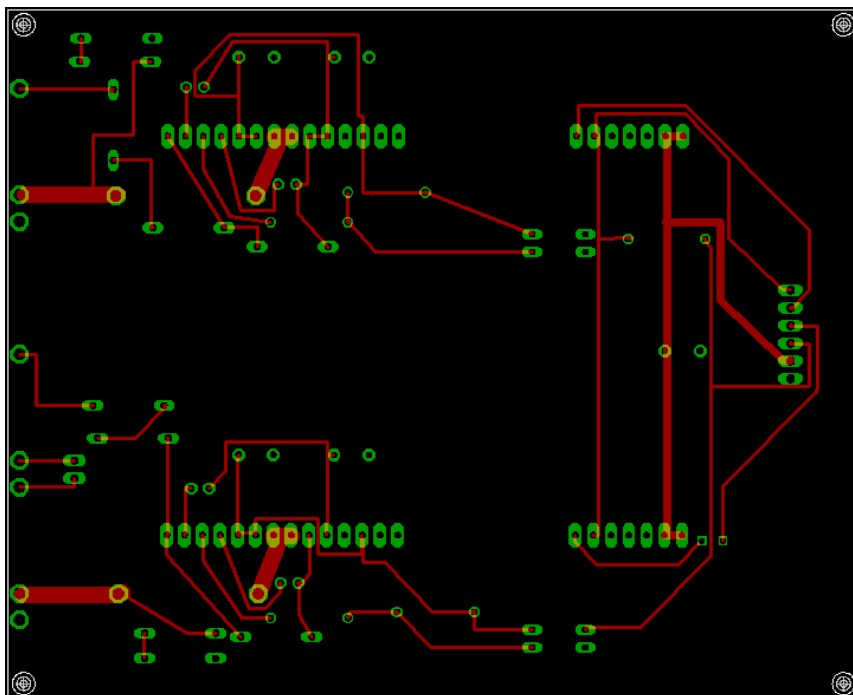

Figure 4b: Component Side Copper

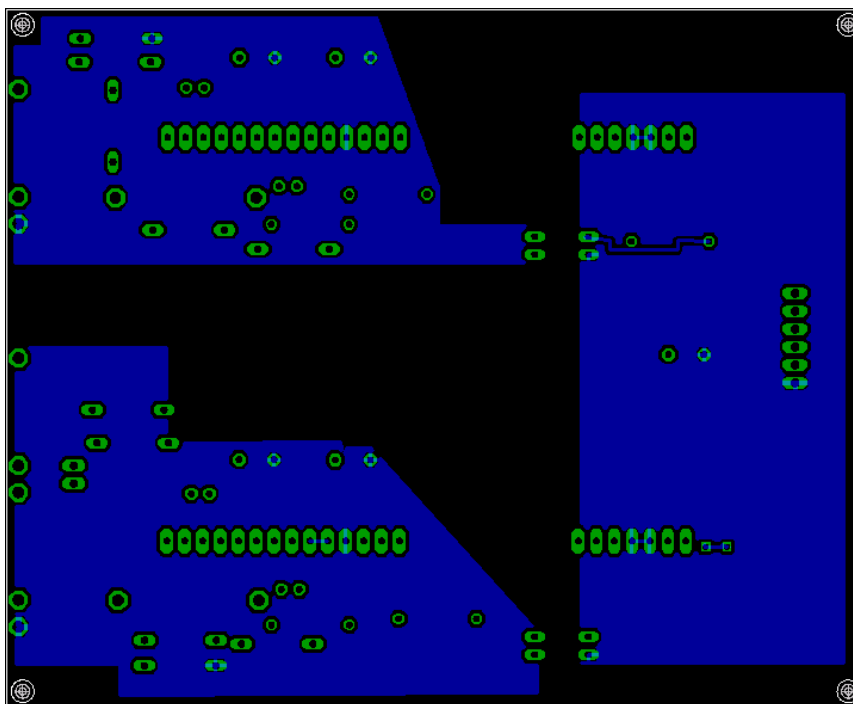

Figure 4c: Solder Side Copper

Additional Information: Detailed information about the operation and electrical characteristics of each VLA500 series hybrid gate driver can be found on the device datasheet. Information about calculating gate drive current and selection of series gate resistors (R_G) can be found in the general IGBT module and gate drive application notes. All of these documents are available on the Powerex website at www.pwr.com. For design assistance with any of the products covered in this application note contact your local Powerex representative or Powerex application engineering at (724) 925-7272.