

# 3

## Contactors

### C310 Series

1 pole  
AC and bi-directional DC  
NO contactors for  
150 A, 300 A and 500 A

Catalogue C310.en

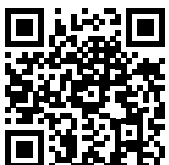
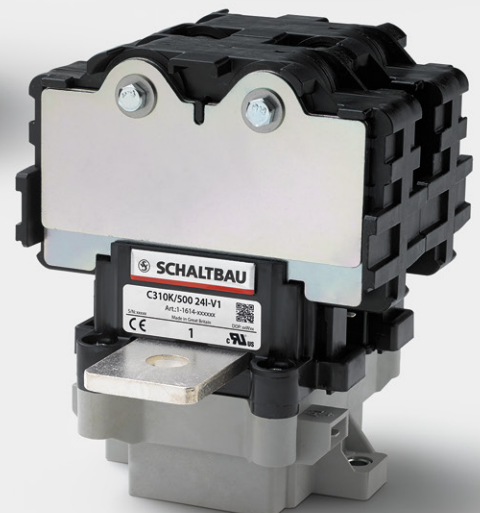

More information  
[schaltbau.com](http://schaltbau.com)

## C310 – 1 pole AC and bi-directional DC NO contactors







Compact single-pole NO contactors for AC and DC up to 1,500 volt rated insulation voltage. Making current up to 2,500 amps; conventional thermal current up to 500 amps; short-time current up to 3,000 amps.

The bi-directional DC contactors switch high powers in a small space. With a making capacity of up to 2,500 amps, the compact switchgear is suitable for applications with high inrush current or high capacities. All versions can continuously conduct up to 500 amps. In the event of a short circuit, 3,000 amps, can even flow for one second without the contacts welding. The contactor therefore maintains its full function in order to disconnect

high power ranges if necessary up to 500 amps and up to 1,500 volts – irrespective of the current direction. This full bi-directionality is important for systems with a charging and discharging process, such as in battery networks or electric vehicles. Other typical application areas are the DC circuit in inverters, combiner boxes in photovoltaic systems or the management of battery storage systems.

### Features





C310 series

-  **Compact dimensions – high rated insulation voltage  $U_i$  up to 1,500 volts**  
Small dimensions – great performance! Nevertheless, all the air gaps in the contact area have been generously dimensioned. The rated insulation voltage is 1,500 volts.  
The arc chamber of the C310 is made of plastic. This is efficient and saves weight.
-  **High short-time withstand current rating  $I_{cw}$  of up to 3,000 amps**  
The C310 can carry a current of up to 3,000 amps for one second without the contacts welding. This is enough time for the short circuit fuse to trip. The short-time withstand current rating is based on high contact forces and optimised silver contacts.
-  **High making capacity  $I_{cm}$  of up to 2,500 amps**  
The C310 can switch on a current of up to 2,500 amps (mono-stable design in a horizontal installation position;  $L/R = 0$  ms). A PWM controller regulates the coil current and ensures low-bounce switch on as well as a low holding power. High contact forces and optimised silver contacts both contribute to the excellent making capacity.
-  **Full bi-directionality – reliable disconnection of high performances**  
All versions of the C310 can reliably disconnect high currents and voltages, irrespective of the current direction. These properties are achieved in the A and K versions through the special arrangement of blowout magnets and arcing chambers, high contact forces and generously dimensioned clearances in the contact area.
-  **High thermal continuous current  $I_{th}$  of up to 500 amps**  
All versions of the C310 can continuously carry up to 500 amps. (Cross-section of the connections: 185 mm<sup>2</sup>, maximum ambient temperature: 85° C; terminal heating: +65 Kelvin). The value is achieved through very high contact forces.
-  **Auxiliary switch with mirror contact function**  
Series C310 contactors are equipped with auxiliary switches with mirror contact function in accordance with DIN EN IEC 60947-4-1, annex F. Mirror contacts are required for the feedback circuits in safety controls. Mirror contacts ensure that the NC contact of the auxiliary contact is not closed at the same time as the NO main contact.

### Standards

C310 series

Contactors meet requirements for industrial applications to:

-  **IEC 60947-4-1**  
Low-voltage switchgear and controlgear – Part 4-1: Contactors and motor starters – Electromechanical contactors and motor starters.
-  **UL 60947-4-1**  
Low-Voltage Switchgear and Controlgear – Part 4-1: Contactors and Motor-Starters – Electromechanical Contactors and Motor-Starters.
-  **ISO 16750-3**  
Road vehicles - Environmental conditions and testing for electrical and electronic equipment – Part 3: Mechanical loads
-  **GB/T 14048.4**  
Low-Voltage Switchgear and Controlgear – Part 4-1: Contactors and Motor-Starters – Electromechanical Contactors and Motor-Starters.

## Reliable, robust and economical

C310 series

Contactors of the C310 series are designed for continuous currents of 150 amps, 300 amps and 500 amps. The switchgear has both high making and breaking capacities, and a high short-time withstand current. This ensures high operational safety.

An integrated electronic coil control ensures a constant and reliable switching behaviour independent of the ambient temperature. In addition, the energy consumption and associated heat development of the monostable design is noticeably reduced when switched on.

Inherent to its design, the bistable version consumes no power in either end positions.

Dependent on the application, high requirements can be placed on electromechanical components. The new DC contactors are highly resistant to shock and vibration loads and meet the high requirements of ISO 16750.

## Ordering key

C310 series

Example: **C310A/500 24I-V1**

| Series, contact configuration |   | Auxiliary switches*, number / type    |    |
|-------------------------------|---|---------------------------------------|----|
| C310                          | 1 pole NO contactor, AC and DC bi-directional | ---                                   | V0 |
| <b>Version</b>                |   | S880 W1R6 k / 1x                      | V1 |
| K                             | 1,500 V DC, large arc chamber                 | S880 W1R6 k / 2x                      | V2 |
| A                             | 1,000 V DC, small arc chamber                 | <b>Coil design</b>                    |    |
| S                             | 60 V DC, without arc chamber                  | I                                     |    |
| <b>Conv. thermal current</b>  |   | B                                     |    |
| 150                           | $I_{th} = 150 \text{ A}$                      | Monostable with integrated PWM module |    |
| 300                           | $I_{th} = 300 \text{ A}$                      | Bistable without PWM module           |    |
| 500                           | $I_{th} = 500 \text{ A}$                      |                                       |    |
| <b>Coil voltage</b>           |   |                                       |    |
| 24                            | Monostable $U_s = 12 \dots 24 \text{ V DC}^*$ | Bistable $U_s = 24 \text{ V DC}$      |    |
| 48                            | $U_s = 48 \text{ V DC}^{**}$                  | $U_s = 48 \text{ V DC}$               |    |
| <b>Accessories</b>            |   |                                       |    |
| C310-TP                       | Deflection shield, C310A/... only             |                                       |    |

\* Operating range 9.5 ... 36 V DC    \*\* Operating range 33.6 ... 60 V DC



**Note:**

\* with mirror contact function according to IEC 60947-4-1, annex F

Presented in this catalogue are only stock items which can be supplied in short delivery time. For some variants minimum quantities apply. Please do not hesitate to ask for the conditions.

**Special variants:**

If you need a special variant of the contactor, please do not hesitate to contact us. Maybe the type of contactor you are looking for is among our many special designs. If not, we can also supply customized designs. In this case, however, minimum order quantities apply.

## Application

C310 series

Thanks to many years of experience and competence developing electromechanical switchgear and the mastering DC arcs, Schaltbau has developed an innovative solution with new DC contactors that significantly simplifies applications with DC switching technology. Since the C310 series safely controls both current directions, the contactors are ideal for all applications involving energy recovery. A typical example here is energy storage, where batteries are

repeatedly charged and discharged. Other application areas for the C310 series are regenerative systems, DC charging stations and photovoltaic systems. In battery powered and hybrid vehicles, the devices can be used directly as the main contactor in the battery disconnect unit (BDU). This reliably ensures the disconnection of both poles from the vehicle in the event of a short circuit.



**Photovoltaics**

- DC switching in central inverters
- Electrical cabinet (combiner boxes)
- Home energy storage systems



**Battery energy storage systems**

- Grid stabilization and battery energy storages
- Regenerative systems in industrial plants
- Battery management systems
- Home energy storages



**E-mobility:**

- Electrical vehicles, hybrid vehicles and trolley busses
- DC charging station
- Battery test systems

**C310 – Version «K»** Circuit diagram, dimension diagram

C310 series

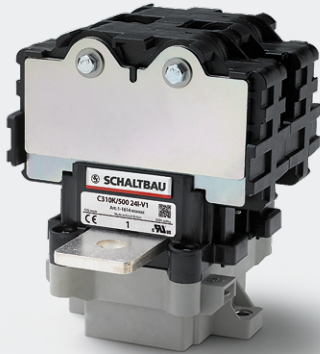

**C310K/ – 1 pole NO contactor**  
AC or bi-directional DC

- Large arc chamber for significantly higher breaking capacity
- Rated insulation voltage  $U_i$  up to 1,500 V
- Rated short-circuit making capacity  $I_{cm}$  up to 2,500 A
- Conventional free air thermal current  $I_{th}$  up to 500 A
- Rated short-time withstand current  $I_{cw}$  up to 3,000 A

**Arc chamber main contact system**  
Highly efficient plastic arc chamber with permanent magnetic blowing

**Aux. switch**  
S880, SPDT, flat tabs 2.8 x 0.5 mm

**Coil terminal**  
Flat tabs 6.3 x 0.8 mm

**Main contact terminals**

| Series        | Material              |   |
|---------------|-----------------------|---|
| C310K/150 ... | Copper                | ⊕ |
| C310K/300 ... | Copper                |   |
| C310K/500 ... | Copper, silver plated |   |
| Series        | Thickness             |   |
| C310K/150 ... | 3 mm                  | ⊕ |
| C310K/300 ... | 5 mm                  |   |
| C310K/500 ... | 5 mm                  |   |
| Series        | Diameter              |   |
| C310K/150 ... | ∅ 9 mm                | ⊕ |
| C310K/300 ... | ∅ 11 mm               |   |
| C310K/500 ... | ∅ 11 mm               |   |

**Circuit diagram**

|  | Monostable * | Bistable ** |
|--|--------------|-------------|
| <b>C310K/...</b><br>Main contacts<br>1x NO<br>Number of auxiliary switches<br>none                   |              |             |
| <b>C310K/...</b><br>Main contacts<br>1x NO<br>Number of auxiliary switches***<br>1x SPDT S880 W1R6 k |              |             |
| <b>C310K/...</b><br>Main contacts<br>1x NO<br>Number of auxiliary switches***<br>2x SPDT S880 W1R6 k |              |             |



- \* Coil suppression integrated, additional circuit is not allowed!
- \*\* Switching by reversing the polarity, voltage pulse 0.5 sec max.
- \*\*\* Auxiliary switches with mirror contact function according to EN 60947-4-1, annex F

**Dimension diagram C310K/...**

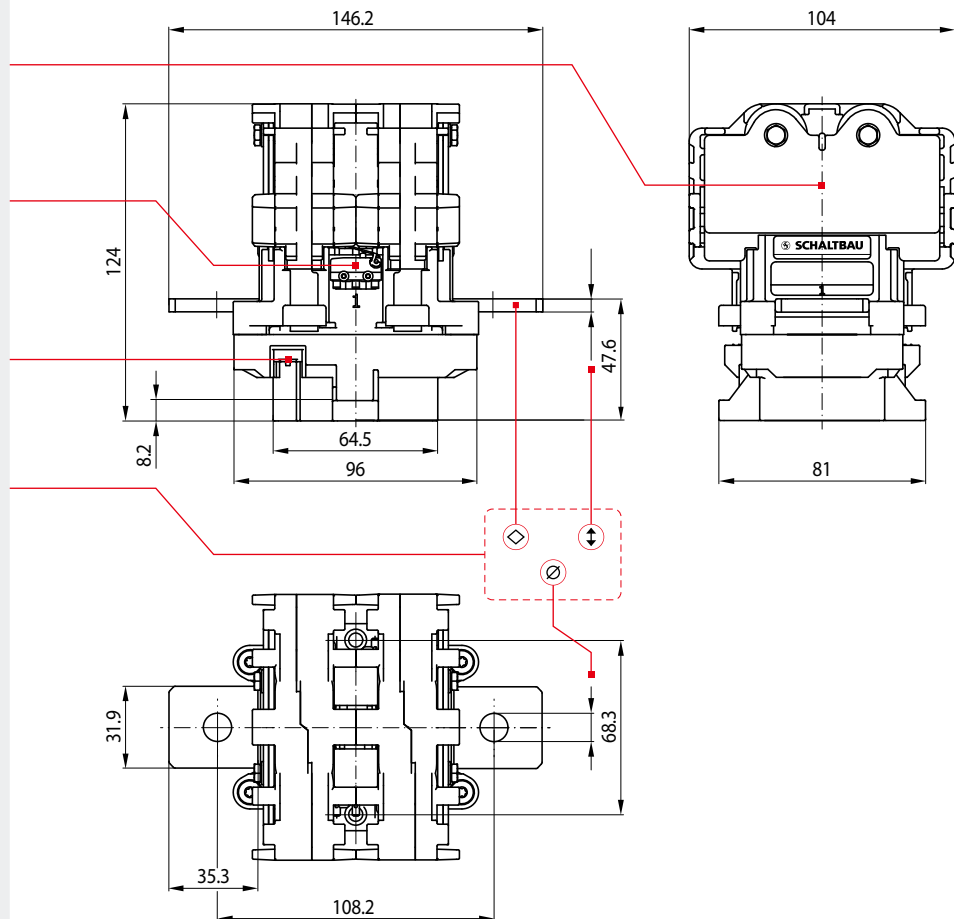

**Specifications** Version «K» for  $U_e = 1,500$  V DC

C310 series

| Series   | C310K/150   | C310K/300  | C310K/500                            |   |
|--|---|--|--------------------------------------|---|
| <b>Type of voltage</b>   | DC, bi-directional / AC, $f \leq 60$ Hz   |  |                                      |   |
| <b>Main contacts, configuration</b>  | 1x NO   |  |                                      |   |
| <b>Electrical data according to IEC/UL 60947-4-1, GB/T 14048.4-2010</b>  |   |  |                                      |   |
| Rated operational voltage $U_e$  | 1,000 V @ PD3 / 1,500 V @ PD2   |  |                                      |   |
| Rated insulation voltage $U_i$   | 1,000 V @ PD3 / 1,500 V @ PD2   |  |                                      |   |
| Rated impulse withstand voltage $U_{imp}$  | 8 kV  |  |                                      |   |
| Pollution degree / Overvoltage category  | PD2, PD3: see $U_e$ and $U_i$ / OV3   |  |                                      |   |
| Conventional free air thermal current $I_{th}$   | $T_a = 40^\circ\text{C}$ (cross section)<br>$T_a = 70^\circ\text{C}$ (cross section)  | 150 A (50 mm <sup>2</sup> )  | 300 A (185 mm <sup>2</sup> )         | 500 A (2x 150 mm <sup>2</sup> )<br>400 A (240 mm <sup>2</sup> ) |
| Power dissipation per pole $I_{th}$ @ 40 °C  | typ.  | 3 W  | 11 W                                 | 30 W  |
| Pole impedance   | typ.  | 120 $\mu\Omega$  | 120 $\mu\Omega$                      | 120 $\mu\Omega$   |
| Utilization category AC-1* $U_e = 750$ V   | IEC 60947-4-1   |  |                                      |   |
| Rated operational current $I_e$  | IEC 60947-4-1   | 60 A   | 60 A                                 | 60 A  |
| Utilization category DC-1* $U_e = 750$ V   | IEC 60947-4-1, GB/T 14048.4-2010  |  |                                      |   |
| Rated operational current $I_e$  | IEC 60947-4-1, GB/T 14048.4-2010  | 60 A   | 60 A                                 | 60 A  |
| Utilization category DC-1* / DC general use $U_e = 600$ V  | UL 60947-4-1  |  |                                      |   |
| Rated operational current $I_e$  | UL 60947-4-1  | 50 A   | 50 A                                 | 50 A  |
| Frequency of operation (operations per hour) $I_e$   | AC-1 & DC-1   | 360 h <sup>-1</sup>  | 360 h <sup>-1</sup>                  | 360 h <sup>-1</sup>   |
| Rated short-time withstand current $I_{cw}$  | $t = 1$ s   | 3,000 A  |                                      |   |
| Short circuit protection device for contactors (w/o thermal overload relay)<br>$U_e = 900$ V DC, $I_{prosp} = 10$ kA, coord. type "2", fuse: SIBA SQB-DC 2 (aR Type) |   | 200 A  | 315 A                                | 2x 250 A (parallel)   |
| <b>Additional electrical ratings of main circuit</b>   |   |  |                                      |   |
| Conventional free air thermal current $I_{th}$   | $T_a = 85^\circ\text{C}$ (cross section)<br>Terminal heating  | 200 A (50 mm <sup>2</sup> )<br>45 K  | 350 A (120 mm <sup>2</sup> )<br>45 K | 500 A (185 mm <sup>2</sup> )<br>65 K                            |
| Power dissipation per pole   | $I_{th}$ @ 40 °C, typ.  | 5 W  | 15 W                                 | 30 W  |
| Pole impedance   | typ.  | 125 $\mu\Omega$  | 120 $\mu\Omega$                      | 120 $\mu\Omega$   |
| Rated short-circuit making capacity $I_{cm}$ (L/R = 0 ms)<br>For mono- or bistable drive (depending on mounting position)  |   | monostable: horizontal: 2,500 A, vertical: 2,000 A<br>bistable: horizontal: 750 A, vertical: 750 A   |                                      |   |
| Breaking capacity  | $L_{max} = 0.25$ mH, other values on request  | 10 operations<br>20 operations<br>25 operations<br>10 operations<br>15 operations  |                                      |   |
| Single contact   | $U_e = 1.500$ V / $I_e = 300$ A<br>$U_e = 1.000$ V / $I_e = 500$ A<br>$U_e = 900$ V / $I_e = 700$ A<br>$U_e = 750$ V / $I_e = 1.000$ A<br>$U_e = 500$ V / $I_e = 1.500$ A | 10 operations<br>20 operations<br>25 operations<br>10 operations<br>15 operations  |                                      |   |
| Double contact circuit   | $U_e = 1.500$ V / $I_e = 1.000$ A<br>$U_e = 1.000$ V / $I_e = 1.700$ A  | 10 operations<br>15 operations   |                                      |   |
| Electrical endurance   |   | 6,000 operations @ DC (L/R = 1 ms), AC ( $\cos\phi = 0.8$ ): 750 V / 60 A  |                                      |   |
| <b>Main contacts</b>   |   |  |                                      |   |
| Contact material   | AgSnO <sub>2</sub>  | AgSnO <sub>2</sub>   | AgSnO <sub>2</sub>                   |   |
| Terminals  | M8  | M10  | M10                                  |   |
| Torque   | 4.8 ... 6 Nm  | 8 ... 10 Nm  | 8 ... 10 Nm                          |   |
| <b>Auxiliary contacts</b>  |   |  |                                      |   |
| Number, configuration / Contact material   | 2x S880 W1R6 k max. / Silver  |  |                                      |   |
| Making / Breaking capacity S880  | AC-15: 230 V AC / 1.0 A DC-13: 60 V DC / 0.5 A  |  |                                      |   |
| Minimum voltage / Current  | 5 V / 5 mA  |  |                                      |   |
| Terminals  | Flat quick connect 2.8 x 0.5 mm   |  |                                      |   |
| <b>Magnetic drive (monostable)</b>   |   |  |                                      |   |
| Rated control supply voltage $U_s$ (Operating range)   | 12 ... 24 V DC (9.5 ... 36 V DC) / 48 V DC (33.6 ... 60 V DC)   |  |                                      |   |
| Pollution degree / Overvoltage category  | PD3 / OV2   |  |                                      |   |
| Coil power dissipation, max. ( $T_a = 20^\circ\text{C} / U_s$ )  | 50 W (24 V) / 2.6 W   |  |                                      |   |
| Pull-in power (0.2 s) / Holding power  |   |  |                                      |   |
| Frequency of operation (operations per hour, no load)  | $T_a = 20^\circ\text{C} / 70^\circ\text{C}$   | 3,600 h <sup>-1</sup> / 1,800 h <sup>-1</sup>  |                                      |   |
| Pull-in time ( $T_a = 20^\circ\text{C} / U_s$ ) / Drop-off time ( $T_a = 20^\circ\text{C} / U_s$ )   | typ.  | 33 ms / 25 ms  |                                      |   |
| Coil suppression (integrated) / Coil terminal  | Suppressor diode / Flat tap 6.3 x 0.8 mm  |  |                                      |   |
| <b>Magnetic drive (bistable)</b>   |   |  |                                      |   |
| Rated control supply voltage $U_s$   | 24 / 48 V DC @ ON time 0.1 ... 0.5 s max.   |  |                                      |   |
| Pollution degree / Overvoltage category  | PD3 / OV2   |  |                                      |   |
| Coil tolerance   | -30 % ... +25 % $U_s$   |  |                                      |   |
| Coil power dissipation, max. ( $T_a = 20^\circ\text{C} / U_s$ )  | 35 W  |  |                                      |   |
| Frequency of operation (operations per hour, no load)  | $T_a = 20^\circ\text{C} / 70^\circ\text{C}$   | 1,800 h <sup>-1</sup> / 1,800 h <sup>-1</sup>  |                                      |   |
| Pull-in time ( $T_a = 20^\circ\text{C} / U_s$ ) / Drop-off time ( $T_a = 20^\circ\text{C} / U_s$ )   | typ.  | 20 ms / 13 ms  |                                      |   |
| Coil suppression (integrated) / Coil terminal  | Suppressor diode / Flat tap 6.3 x 0.8 mm  |  |                                      |   |
| <b>Mounting position</b>   |   |  |                                      |   |
| Degree of protection   | IEC 60529   | IP00   |                                      |   |
| Mechanical endurance   | main contacts monostable / bistable<br>auxiliary contacts   | 2,000,000 operations / 100,000 operations<br>1,000,000 operations  |                                      |   |
| Shock / Vibration  | IEC 61373 / ISO 16750-3   | Category 1, Class B / Class C  |                                      |   |
| Temperatures   | Operating temperature / Storage temperature<br>Altitude / Humidity (EN 50125-1)   | -40 °C ... +85 °C / -40 °C ... +85 °C<br>< 4,500 m @ $U_i = 1,000$ V / < 3,500 m @ $U_i = 1,500$ V above sea level / < 75 % on an annual average |                                      |   |
| Weight   |   | 1.24 kg  | 1.31 kg                              | 1.35 kg   |

\* Corresponds to 50 switching operations  $1.5 \times I_e$  and 6,000 switching operations  $1.0 \times I_e$

**C310 – Version «A»** Circuit diagram, dimension diagram

C310 series



**C310A/ – 1 pole NO contactor  
AC or bi-directional DC**

- Rated insulation voltage  $U_i$  up to 1,500 V, version with small arc chamber
- Rated short-circuit making capacity  $I_{cm}$  up to 2,500 A
- Conventional free air thermal current  $I_{th}$  up to 500 A
- Rated short-time withstand current  $I_{cw}$  up to 3,000 A

**Circuit diagram**

|  | Monostable * | Bistable ** |
|--|--------------|-------------|
| <b>C310A/...</b><br>Main contacts<br>1x NO<br>Number of auxiliary switches<br>none                   |              |             |
| <b>C310A/...</b><br>Main contacts<br>1x NO<br>Number of auxiliary switches***<br>1x SPDT S880 W1R6 k |              |             |
| <b>C310A/...</b><br>Main contacts<br>1x NO<br>Number of auxiliary switches***<br>2x SPDT S880 W1R6 k |              |             |



- \* Coil suppression integrated, additional circuit is not allowed!
- \*\* Switching by reversing the polarity, voltage pulse 0.5 sec max.
- \*\*\* Auxiliary switches with mirror contact function according to EN 60947-4-1, annex F

**Dimension diagram C310A/...**

- Arc chamber cover**  
Reduces the distance to live, metallic or grounded parts
- Arc chamber main contact system**  
Highly efficient plastic arc chamber with permanent magnetic blowing
- Aux. switch**  
S880, SPDT, flat tabs 2.8 x 0.5 mm
- Coil terminal**  
Flat tabs 6.3 x 0.8 mm

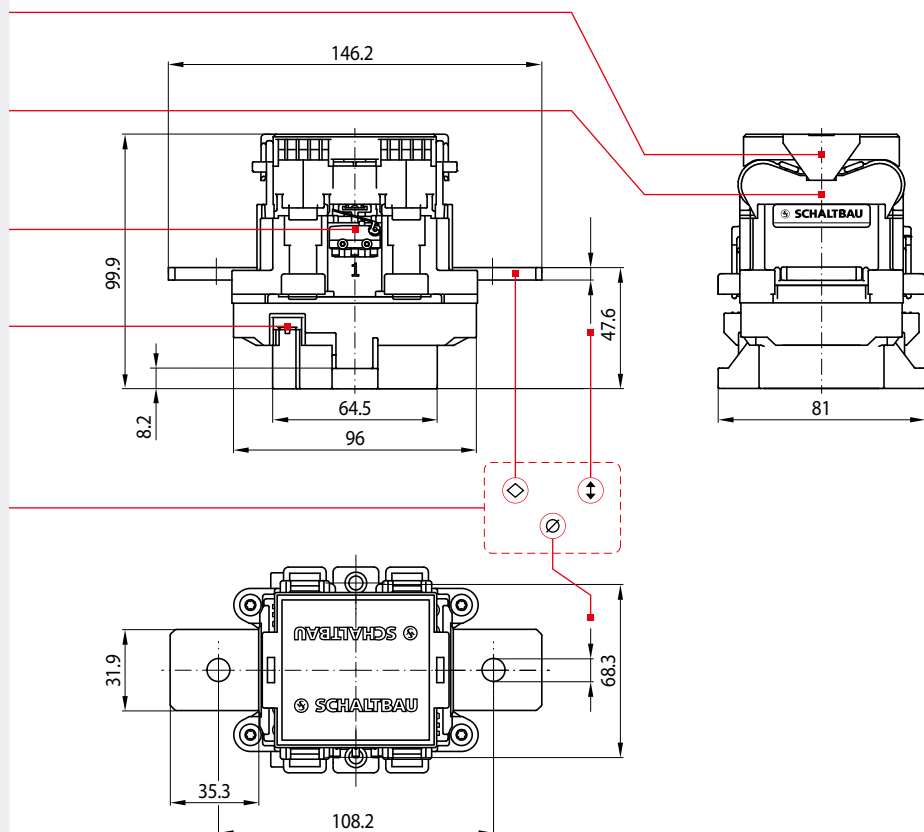

**Main contact terminals**

| Series        | Material              | Thickness | Diameter |
|---------------|-----------------------|-----------|----------|
| C310A/150 ... | Copper                | 3 mm      | ∅ 9 mm   |
| C310A/300 ... | Copper                | 5 mm      | ∅ 11 mm  |
| C310A/500 ... | Copper, silver plated | 5 mm      | ∅ 11 mm  |

**Specifications** Version «A» for  $U_e = 1,500$  V DC

C310 series

| Series   |   | C310A/150  | C310A/300  | C310A/500   |
|--|---|--|--|---|
| <b>Type of voltage</b>   |   | DC, bi-directional / AC, $f \leq 60$ Hz  |  |   |
| <b>Main contacts, configuration</b>  |   | 1x NO  |  |   |
| <b>Electrical data according to IEC/UL 60947-4-1, GB/T 14048.4-2010</b>  |   |  |  |   |
| Rated operational voltage $U_e$  |   | 1,000 V @ PD3 / 1,500 V @ PD2  |  |   |
| Rated insulation voltage $U_i$   |   | 1,000 V @ PD3 / 1,500 V @ PD2  |  |   |
| Rated impulse withstand voltage $U_{imp}$  |   | 10 kV  |  |   |
| Pollution degree / Overvoltage category  |   | PD2, PD3: see $U_e$ and $U_i$ / OV3  |  |   |
| Conventional free air thermal current $I_{th}$   | $T_a = 40^\circ$ C (cross section)<br>$T_a = 70^\circ$ C (cross section)  | 150 A (50 mm <sup>2</sup> )  | 300 A (185 mm <sup>2</sup> )   | 500 A (2x 150 mm <sup>2</sup> )<br>400 A (240 mm <sup>2</sup> ) |
| Power dissipation per pole $I_{th}$ @ 40 °C  | typ.  | 3.5 W  | 11 W   | 30 W  |
| Pole impedance   | typ.  | 150 $\mu\Omega$  | 120 $\mu\Omega$  | 120 $\mu\Omega$   |
| Utilization category AC-1* $U_e = 750$ V<br>Rated operational current $I_e$  | IEC 60947-4-1   | 60 A   | 60 A   | 60 A  |
| Utilization category DC-1* $U_e = 750$ V<br>Rated operational current $I_e$  | IEC 60947-4-1, GB/T 14048.4-2010  | 60 A   | 60 A   | 60 A  |
| Utilization category DC-1* / DC general use $U_e = 600$ V<br>Rated operational current $I_e$   | UL 60947-4-1  | 50 A   | 50 A   | 50 A  |
| Frequency of operation (operations per hour) $I_e$   | AC-1 & DC-1   | 360 h <sup>-1</sup>  | 360 h <sup>-1</sup>  | 360 h <sup>-1</sup>   |
| Rated short-time withstand current $I_{cw}$  | t = 1 s   |  | 3,000 A  |   |
| Short circuit protection device for contactors (w/o thermal overload relay)<br>$U_e = 900$ V DC, $I_{prosp} = 10$ kA, coord. type "2", fuse: SIBA SQB-DC 2 (aR Type) |   | 200 A  | 315 A  | 2x 250 A (parallel)   |
| <b>Additional electrical ratings of main circuit</b>   |   |  |  |   |
| Conventional free air thermal current $I_{th}$   | $T_a = 85^\circ$ C (cross section)<br>Terminal heating  | 200 A (50 mm <sup>2</sup> )<br>45 K  | 350 A (120 mm <sup>2</sup> )<br>45 K   | 500 A (185 mm <sup>2</sup> )<br>65 K                            |
| Power dissipation per pole   | $I_{th}$ @ 40 °C, typ.  | 5 W  | 15 W   | 30 W  |
| Pole impedance   | typ.  | 125 $\mu\Omega$  | 120 $\mu\Omega$  | 120 $\mu\Omega$   |
| Rated short-circuit making capacity $I_{cm}$ (L/R = 0 ms)<br>For mono- or bistable drive (depending on mounting position)  |   |  | monostable: horizontal: 2,500 A, vertical: 2,000 A<br>bistable: horizontal: 750 A, vertical: 750 A |   |
| Breaking capacity<br>Single contact  | $L_{max} = 0.25$ mH, other values on request<br>$U_e = 1,500$ V / $I_e = 50$ A<br>$U_e = 900$ V / $I_e = 400$ A<br>$U_e = 750$ V / $I_e = 500$ A<br>$U_e = 500$ V / $I_e = 800$ A |  | 60 operations<br>60 operations<br>60 operations<br>60 operations                                   |   |
| Double contact circuit   | $U_e = 1,500$ V / $I_e = 500$ A<br>$U_e = 1,000$ V / $I_e = 800$ A  |  | 60 operations<br>60 operations   |   |
| Electrical endurance   |   | 6,000 operations @ DC (L/R = 1 ms), AC (cos $\phi$ = 0.8): 750 V / 60 A  |  |   |
| <b>Main contacts</b>   |   |  |  |   |
| Contact material   |   | AgSnO <sub>2</sub>   | AgSnO <sub>2</sub>   | AgSnO <sub>2</sub>  |
| Terminals  |   | M8   | M10  | M10   |
| Torque   |   | 4.8 ... 6 Nm   | 8 ... 10 Nm  | 8 ... 10 Nm   |
| <b>Auxiliary contacts</b>  |   |  |  |   |
| Number, configuration / Contact material   |   | 2x S880 W1R6 k max. / Silver   |  |   |
| Making / Breaking capacity S880  |   | AC-15: 230 V AC / 1.0 A DC-13: 60 V DC / 0.5 A   |  |   |
| Minimum voltage / Current  |   | 5 V / 5 mA   |  |   |
| Terminals  |   | Flat quick connect 2.8 x 0.5 mm  |  |   |
| <b>Magnetic drive (monostable)</b>   |   |  |  |   |
| Rated control supply voltage $U_c$ (Operating range)<br>Pollution degree / Overvoltage category  |   | 12 ... 24 V DC (9.5 ... 36 V DC) / 48 V DC (33.6 ... 60 V DC)<br>PD3 / OV2   |  |   |
| Coil power dissipation, max. ( $T_a = 20^\circ$ C / $U_c$ )<br>Pull-in power (0.2 s) / Holding power   |   | 50 W (24 V) / 2.6 W  |  |   |
| Frequency of operation (operations per hour, no load)  | $T_a = 20^\circ$ C / 70 °C  | 3,600 h <sup>-1</sup> / 1,800 h <sup>-1</sup>  |  |   |
| Pull-in time ( $T_a = 20^\circ$ C / $U_c$ ) / Drop-off time ( $T_a = 20^\circ$ C / $U_c$ )<br>Coil suppression (integrated) / Coil terminal                          | typ.  | 33 ms / 25 ms<br>Suppressor diode / Flat tap 6.3 x 0.8 mm  |  |   |
| <b>Magnetic drive (bistable)</b>   |   |  |  |   |
| Rated control supply voltage $U_c$ (Min. operating voltage)<br>Pollution degree / Overvoltage category   |   | 24 V DC (16.8 V DC) @ ON time 0.1 ... 0.5 s max. / 48 V DC (33.6 V DC) @ ON time 0.1 ... 0.5 s max.<br>PD3 / OV2                                 |  |   |
| Coil power dissipation, max. ( $T_a = 20^\circ$ C / $U_c$ )  |   | 35 W   |  |   |
| Frequency of operation (operations per hour, no load)  | $T_a = 20^\circ$ C / 70 °C  | 1,800 h <sup>-1</sup> / 1,800 h <sup>-1</sup>  |  |   |
| Pull-in time ( $T_a = 20^\circ$ C / $U_c$ ) / Drop-off time ( $T_a = 20^\circ$ C / $U_c$ )<br>Coil suppression (integrated) / Coil terminal                          | typ.  | 20 ms / 13 ms<br>Suppressor diode / Flat tap 6.3 x 0.8 mm  |  |   |
| <b>Mounting position</b>   |   | vertical / horizontal (mounting see page 11)   |  |   |
| <b>Degree of protection</b>  | IEC 60529   | IP00   |  |   |
| <b>Mechanical endurance</b>  | main contacts monostable / bistable<br>auxiliary contacts   | 2,000,000 operations / 100,000 operations<br>1,000,000 operations  |  |   |
| <b>Shock / Vibration</b>   | IEC 61373 / ISO 16750-3   | Category 1, Class B / Class C  |  |   |
| <b>Temperatures</b>  | Operating temperature / Storage temperature<br>Altitude / Humidity (EN 50125-1)   | -40 °C ... +85 °C / -40 °C ... +85 °C<br>< 4,500 m @ $U_i = 1,000$ V / < 3,500 m @ $U_i = 1,500$ V above sea level / < 75 % on an annual average |  |   |
| <b>Weight</b>  |   | 0.83 kg  | 0.90 kg  | 0.95 kg   |

\* Corresponds to 50 switching operations  $1.5 \times I_e$  and 6,000 switching operations  $1.0 \times I_e$ 

Subject to change

**C310 – Version «S»** Circuit diagram, dimension diagram

C310 series

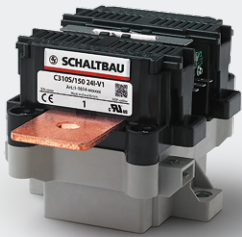

**C310S/ – 1 pole NO contactor  
AC or bi-directional DC**

- Rated insulation voltage  $U_i$  up to 1,500 V, version without arc chamber
- Rated short-circuit making capacity  $I_{cm}$  up to 2,500 A
- Conventional free air thermal current  $I_{th}$  up to 500 A
- Rated short-time withstand current  $I_{cw}$  up to 3,000 A

**Circuit diagram**

|  | Monostable *                           | Bistable **                                |
|--|--|--|
| <b>C310S/...</b><br>Main contacts<br>1x NO<br>Number of auxiliary switches<br>none                   | A1 + 1<br><br>A2 - 2                   | A1 +/- 1<br><br>A2 +/- 2                   |
| <b>C310S/...</b><br>Main contacts<br>1x NO<br>Number of auxiliary switches***<br>1x SPDT S880 W1R6 k | A1 + 1 12 14<br><br>A2 - 2 11          | A1 +/- 1 12 14<br><br>A2 +/- 2 11          |
| <b>C310S/...</b><br>Main contacts<br>1x NO<br>Number of auxiliary switches***<br>2x SPDT S880 W1R6 k | A1 + 1 12 14 22 24<br><br>A2 - 2 11 21 | A1 +/- 1 12 14 22 24<br><br>A2 +/- 2 11 21 |



- \* Coil suppression integrated, additional circuit is not allowed!
- \*\* Switching by reversing the polarity, voltage pulse 0.5 sec max.
- \*\*\* Auxiliary switches with mirror contact function according to EN 60947-4-1, annex F

**Dimension diagram C310S/...**

**Switching chamber**  
Main contact system w/o arc chamber

**Aux. switch**  
S880, SPDT, flat tabs 2.8 x 0.5 mm

**Coil terminal**  
Flat tabs 6.3 x 0.8 mm

**Main contact terminals**

| Series        | Material              |   |
|---------------|-----------------------|---|
| C310S/150 ... | Copper                | ⊙ |
| C310S/300 ... | Copper                |   |
| C310S/500 ... | Copper, silver plated |   |
| Series        | Thickness             |   |
| C310S/150 ... | 3 mm                  | ⊕ |
| C310S/300 ... | 5 mm                  |   |
| C310S/500 ... | 5 mm                  |   |
| Series        | Diameter              |   |
| C310S/150 ... | ø 9 mm                | ⊙ |
| C310S/300 ... | ø 11 mm               |   |
| C310S/500 ... | ø 11 mm               |   |

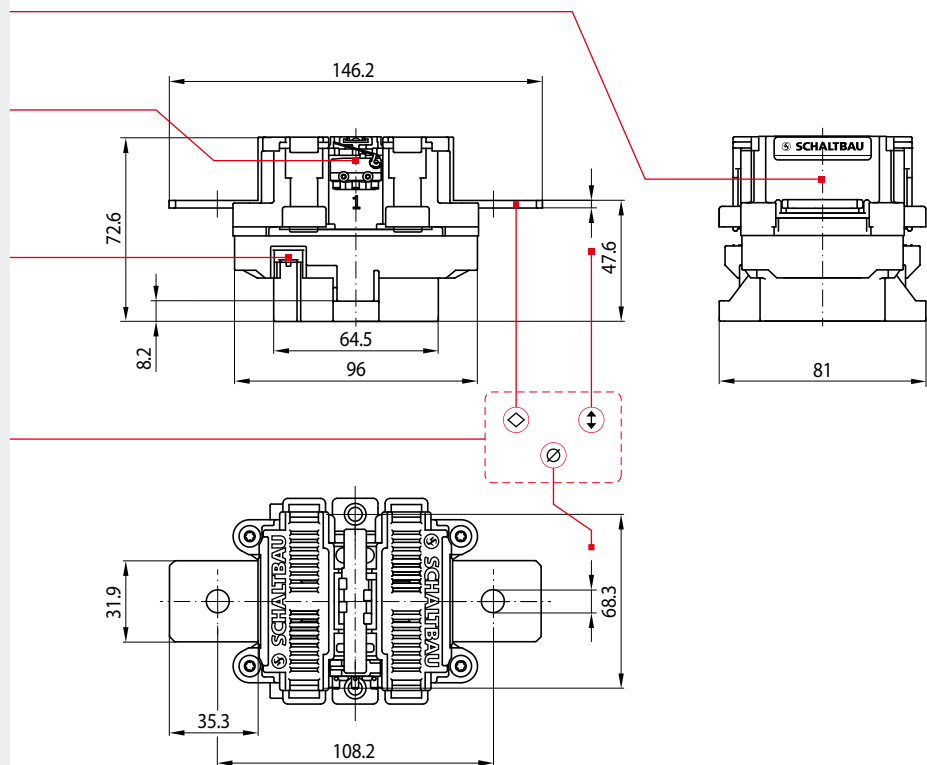



**Specifications** Version «S» for  $U_e = 60$  V DC

C310 series

| Series  |   | C310S/150  | C310S/300   | C310S/500   |
|---|---|--|---|---|
| <b>Type of voltage</b>  |   | DC, bi-directional / AC, $f \leq 60$ Hz  |   |   |
| <b>Main contacts, configuration</b>   |   | 1x NO  |   |   |
| <b>Electrical data according to IEC/UL 60947-4-1, GB/T 14048.4-2010</b>   |   |  |   |   |
| Rated operational voltage $U_e$   |   | 60 V @ PD3   |   |   |
| Rated insulation voltage $U_i$  |   | 1,000 V @ PD3 / 1,500 V @ PD2  |   |   |
| Rated impulse withstand voltage $U_{imp}$   |   | 10 kV  |   |   |
| Pollution degree / Overvoltage category   |   | PD2, PD3: see $U_e$ and $U_i$ / OV3  |   |   |
| Conventional free air thermal current $I_{th}$  | $T_a = 40^\circ$ C (cross section)<br>$T_a = 70^\circ$ C (cross section)        | 150 A (50 mm <sup>2</sup> )  | 300 A (185 mm <sup>2</sup> )  | 500 A (2x 150 mm <sup>2</sup> )<br>400 A (240 mm <sup>2</sup> )             |
| Power dissipation per pole $I_{th}$ @ 40 °C   | typ.  | 3.5 W  | 11 W  | 30 W  |
| Pole impedance  | typ.  | 150 $\mu\Omega$  | 120 $\mu\Omega$   | 120 $\mu\Omega$   |
| Utilization category AC-1* / AC general use $U_e = 48$ V<br>Rated operational current $I_e$   |   | 150 A  | 300 A   | 500 A   |
| Utilization category DC-1* / DC general use $U_e = 48$ V<br>Rated operational current $I_e$   |   | 150 A  | 300 A   | 500 A   |
| Frequency of operation $I_e$  | AC-1 & DC-1   | 360 h <sup>-1</sup>  | 360 h <sup>-1</sup>   | 360 h <sup>-1</sup>   |
| Rated short-time withstand current $I_{cw}$   | t = 1 s   | 3,000 A  |   |   |
| Short circuit protection device for contactors  |   | on request   | on request  | on request  |
| <b>Additional electrical ratings of main circuit</b>  |   |  |   |   |
| Conventional free air thermal current $I_{th}$  | $T_a = 85^\circ$ C (cross section)<br>Terminal heating                          | 200 A (50 mm <sup>2</sup> )<br>45 K  | 350 A (120 mm <sup>2</sup> )<br>45 K  | 500 A (185 mm <sup>2</sup> )<br>65 K  |
| Power dissipation per pole  | $I_{th}$ @ 40 °C, typ.  | 5 W  | 15 W  | 30 W  |
| Pole impedance  | typ.  | 125 $\mu\Omega$  | 120 $\mu\Omega$   | 120 $\mu\Omega$   |
| Rated short-circuit making capacity $I_{cm}$ (L/R = 0 ms)<br>For mono- or bistable drive (depending on mounting position)                   |   | monostable: horizontal: 2,500 A, vertical: 2,000 A<br>bistable: horizontal: 750 A, vertical: 750 A   |   |   |
| Breaking capacity (L/R = 0.1 ms)  | $U_e = 60$ V / $I_e = 2,000$ A<br>$U_e = 96$ V / $I_e = 1,300$ A                | 60 operations<br>60 operations   |   |   |
| Electrical endurance  |   | 10,000 operations<br>DC (L/R = 1 ms)<br>AC (cos $\phi$ = 0.8): 48 V / 150 A  | 10,000 operations<br>DC (L/R = 1 ms)<br>AC (cos $\phi$ = 0.8): 48 V / 300 A | 10,000 operations<br>DC (L/R = 1 ms)<br>AC (cos $\phi$ = 0.8): 48 V / 500 A |
| <b>Main contacts</b>  |   |  |   |   |
| Contact material  |   | AgSnO <sub>2</sub>   | AgSnO <sub>2</sub>  | AgSnO <sub>2</sub>  |
| Terminals   |   | M8   | M10   | M10   |
| Torque  |   | 4.8 ... 6 Nm   | 8 ... 10 Nm   | 8 ... 10 Nm   |
| <b>Auxiliary contacts</b>   |   |  |   |   |
| Number, configuration / Contact material  |   | 2x S880 W1R6 k max. / Silver   |   |   |
| Making / Breaking capacity S880   |   | AC-15: 230 V AC / 1.0 A DC-13: 60 V DC / 0.5 A   |   |   |
| Minimum voltage / Current   |   | 5 V / 5 mA   |   |   |
| Terminals   |   | Flat quick connect 2.8 x 0.5 mm  |   |   |
| <b>Magnetic drive (monostable)</b>  |   |  |   |   |
| Rated control supply voltage $U_c$ (Operating range)<br>Pollution degree / Overvoltage category   |   | 12 ... 24 V DC (9.5 ... 36 V DC) / 48 V DC (33.6 ... 60 V DC)<br>PD3 / OV2   |   |   |
| Coil power dissipation, max. ( $T_a = 20^\circ$ C / $U_s$ )<br>Pull-in power (0.2 s) / Holding power  |   | 50 W (24 V) / 2.6 W  |   |   |
| Frequency of operation (operations per hour, no load)   | $T_a = 20^\circ$ C / 70 °C  | 3,600 h <sup>-1</sup> / 1,800 h <sup>-1</sup>  |   |   |
| Pull-in time ( $T_a = 20^\circ$ C / $U_s$ ) / Drop-off time ( $T_a = 20^\circ$ C / $U_s$ )<br>Coil suppression (integrated) / Coil terminal | typ.  | 33 ms / 25 ms<br>Suppressor diode / Flat tap 6.3 x 0.8 mm  |   |   |
| <b>Magnetic drive (bistable)</b>  |   |  |   |   |
| Rated control supply voltage $U_c$ (Min. operating voltage)<br>Pollution degree / Overvoltage category                                      |   | 24 V DC (16.8 V DC) @ ON time 0.1 ... 0.5 s max. / 48 V DC (33.6 V DC) @ ON time 0.1 ... 0.5 s max.<br>PD3 / OV2                                 |   |   |
| Coil power dissipation, max. ( $T_a = 20^\circ$ C / $U_s$ )   |   | 35 W   |   |   |
| Frequency of operation (operations per hour, no load)   | $T_a = 20^\circ$ C / 70 °C  | 1,800 h <sup>-1</sup> / 1,800 h <sup>-1</sup>  |   |   |
| Pull-in time ( $T_a = 20^\circ$ C / $U_s$ ) / Drop-off time ( $T_a = 20^\circ$ C / $U_s$ )<br>Coil suppression (integrated) / Coil terminal | typ.  | 20 ms / 13 ms<br>Suppressor diode / Flat tap 6.3 x 0.8 mm  |   |   |
| <b>Mounting position</b>  |   | vertical / horizontal (mounting see page 11)   |   |   |
| <b>Degree of protection</b>   | IEC 60529   | IP00   |   |   |
| <b>Mechanical endurance</b>   | main contacts monostable / bistable<br>auxiliary contacts                       | 2,000,000 operations / 100,000 operations<br>1,000,000 operations  |   |   |
| <b>Shock / Vibration</b>  | IEC 61373 / ISO 16750-3   | Category 1, Class B / Class C  |   |   |
| <b>Temperatures</b>   | Operating temperature / Storage temperature<br>Altitude / Humidity (EN 50125-1) | -40 °C ... +85 °C / -40 °C ... +85 °C<br>< 4,500 m @ $U_i = 1,000$ V / < 3,500 m @ $U_i = 1,500$ V above sea level / < 75 % on an annual average |   |   |
| <b>Weight</b>   |   | 0.55 kg  | 0.63 kg   | 0.65 kg   |

\* Corresponds to 50 switching operations  $1.5 \times I_e$  and 6,000 switching operations  $1.0 \times I_e$

## Minimum distances, deflection shields, mounting holes

C310 series

• **C310K/...**

with large arc chamber

Minimum distance at max. load current

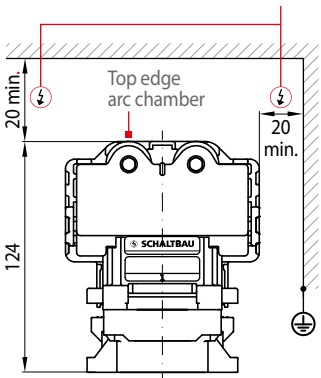

**i** For the C310K/150, C310K/300 and C310K/500 series there is a minimum distance of 20 mm to magnetically active, live or earthed parts.

• **C310A/...**

with arc chamber cover

Minimum distance at max. load current,

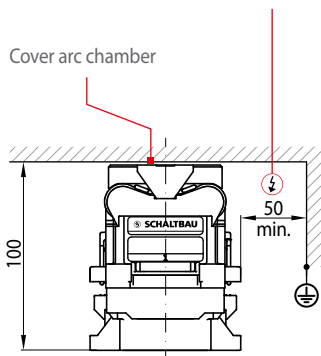

**i** The extinguishing chamber cover is part of the standard scope of delivery for the C310A/150, C310A/300 and C310A/500 series.

• **C310A/...**

w/o arc chamber cover

Minimum distance at max. load current,

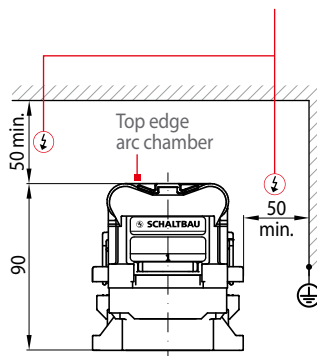

**i** It is permissible to use the C310A/150, C310A/300 and C310A/500 series without arc chamber cover, taking into account additional clearance dimensions.

• **C310S/...**

w/o arc chamber

Cover main contact system

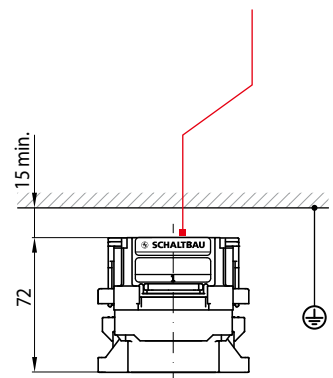

**i** For the C310S/150, C310S/300 and C310S/500 series there is a minimum distance of 15 mm to magnetically active, live or earthed parts.

• **Insertable deflection shields:**

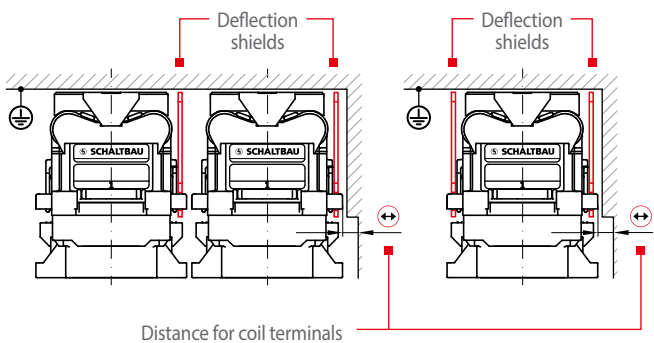

• **Mounting holes**

C310K/...

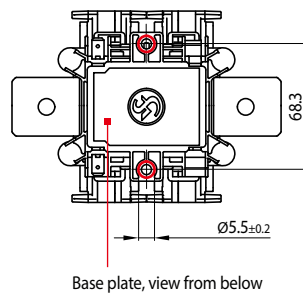

C310A/... and C310S/...

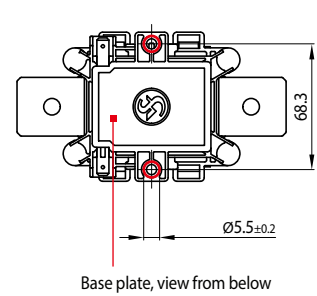

**i** **C310A/... series only:**  
The use of insertable deflection shields reduces the minimum distance to 0 mm. Without deflection shields, the minimum distance of the contactors, depending on the arrangement, can increase to 100 mm.

## Electrical endurance

C310 series

• **Minimum distances** ⚡ to live or earthed parts

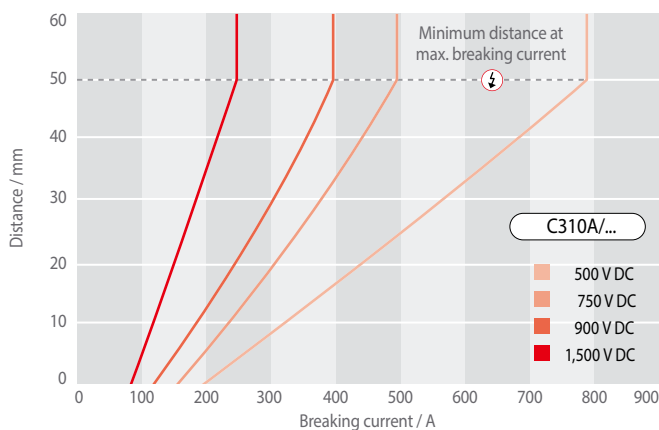

• **Predicted electrical endurance as a function of the breaking current**

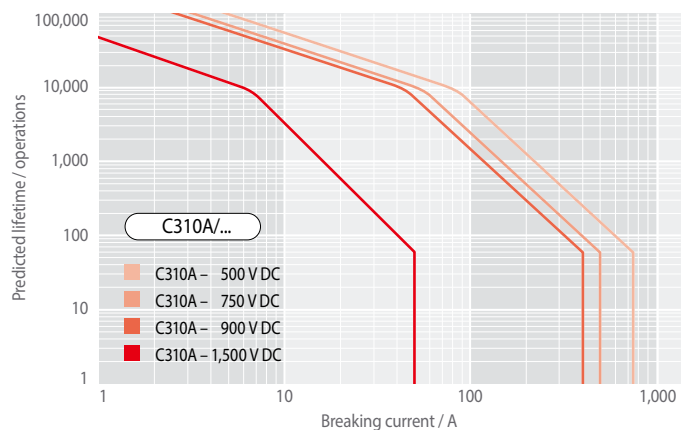

## Mounting instructions

C310 series

### • C310K/...

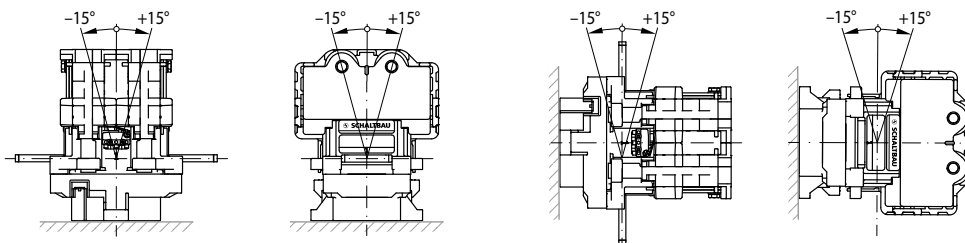

### • C310A/...

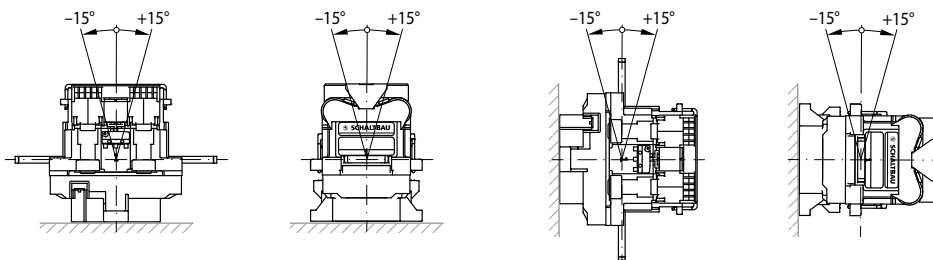

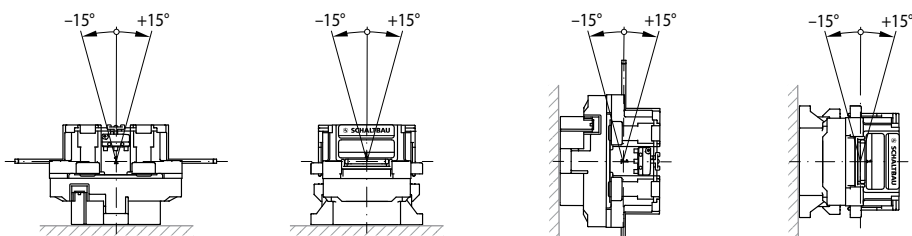

### • C310S/...



Horizontal assembly  
«Table mounting»

Vertical assembly  
«Wall mounting»

 The contactors are mounted on a mounting plate with two M5 screws.

 The contactors can be mounted horizontally or vertically on a prepared mounting plate.

 Mounting positions hanging upside down are not allowed!

## Maintenance and safety instructions

C310 series

### Maintenance:

- C310 series contactors are basically maintenance free.
- Make regular in-depth visual inspections once or twice a year.



**For detailed maintenance, safety and mounting instructions please refer to our operating manuals**  
 ➔ [C310-M.en!](#)

### Safety instructions:

- The device must be used according to the intended purpose as specified in the technical documentation. You are obliged to observe all specifications depending on operating temperature, degree of pollution etc. that are relevant to your application.
- Without further safety measures the contactors are not suited for use in potentially explosive atmospheres.
- In case of malfunction of the device or uncertainties stop using it any longer and contact the manufacturer instantly.
- Tampering with the device can seriously affect the safety of people and equipment. This is not permitted and leads to an exclusion of liability and warranty.
- Coil suppression for reducing surges when the coil is switched off is optimally attuned to the contactors switching behaviour. The existing opening characteristic must not be negatively influenced by parallel connection with an external diode.
- Contactors running permanently may heat up. So make sure that the contactor has sufficiently cooled down before you start any inspection or maintenance work.
- When installing contactors with magnetic blowout make sure to do it in such a way that no magnetizable parts can be attracted by the permanent magnets that are also capable of destroying all data of swipe cards.
- In general, strong electromagnetic fields can be generated in the area around the contactors. These can influence other components in the area of the contactors.
- Improper handling of the contactor, e.g. when hitting the floor with some impact, can result in breakage, visible cracks and deformation.



**Defective contactors or parts (e.g. arc chambers, auxiliary switches) must be replaced immediately!**



**For a detailed list of all safety instructions see here:**  
 ➔ [schaltbau.info/safety3en!](http://schaltbau.info/safety3en!)

# Schaltbau GmbH

For detailed information on our products and services visit our website – or give us a call!

Schaltbau GmbH  
Hollerithstrasse 5  
81829 Munich  
Germany



Phone +49 89 9 30 05-0  
Fax +49 89 9 30 05-350  
Internet [www.schaltbau.com](http://www.schaltbau.com)  
e-Mail [contact@schaltbau.de](mailto:contact@schaltbau.de)



The production facilities of Schaltbau GmbH have been IRIS certified since 2008.



Certified to DIN EN ISO 14001 since 2002. For the most recent certificate visit our website.



Certified to DIN EN ISO 9001 since 1994. For the most recent certificate visit our website.

## Electrical Components and Systems for Railway Engineering and Industrial Applications

### Connectors

- Connectors manufactured to industry standards
- Connectors to suit the special requirements of communications engineering (MIL connectors)
- Charging connectors for battery-powered machines and systems
- Connectors for railway engineering, including UIC connectors
- Special connectors to suit customer requirements

### Snap-action switches

- Snap-action switches with positive opening operation
- Snap-action switches with self-cleaning contacts
- Snap-action switch made of robust polyetherimide (PEI)
- Snap-action switch with two galvanically isolated contact bridges
- Special switches to suit customer requirements

### Contactors Emergency disconnect switches

- Single and multi-pole DC contactors
- High-voltage AC/DC contactors
- Contactors for battery powered vehicles and power supplies
- Contactors for railway applications
- Terminal bolts and fuse holders
- DC emergency disconnect switches
- Special contactors to suit customer requirements

### Electrics for rolling stock

- Equipment for driver's cab
- Equipment for passenger use
- High-voltage switchgear
- High-voltage heaters
- High-voltage roof equipment
- Equipment for electric brakes
- Design and engineering of train electrics to customer requirements