

**Connectors according
to UIC 541-5 VE
EP Series**

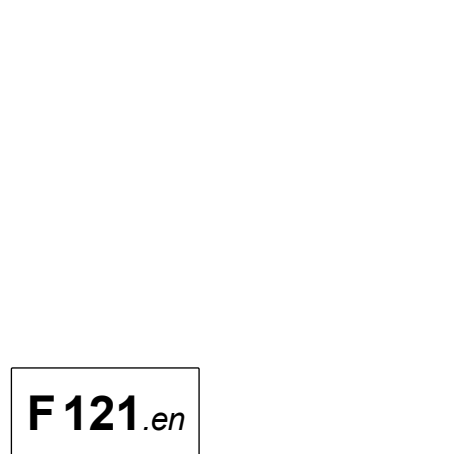
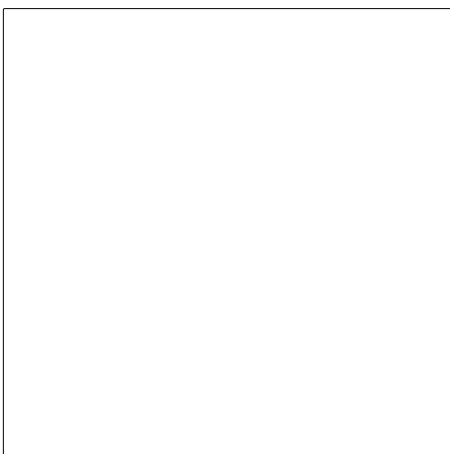
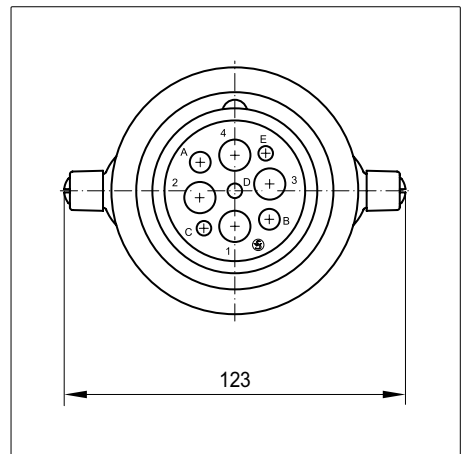
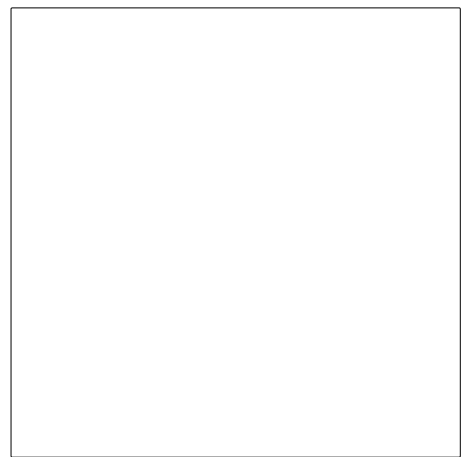

F 121.en

Connector to UIC standard 541-5 VE, EP Series

The connector is designed in accordance with the specifications of the international railway standard UIC 541-5. It adds to the range of our well-proven connectors for the railway industry. This heavy-duty connector is designed to ensure the electrical connection within a train for the electropneumatic brakes (EP brakes) as well as the bypass of an electropneumatic emergency brake.

Both systems have functions which overlap through their control and monitoring elements. They are fed by a common electrical cable that runs the length of the train. Integrated in the receptacle is a switching element as pilot contact which is used for feedback signalling a plug being mated, whereas the end of train is signalled by means of a pin contact in the dummy receptacle.

Features

- **Feedback**
 - Plug being mated: via a switching element integrated in the receptacle shell
 - End of train: via a pin contact in the dummy receptacle
- **Shell:**
 - Receptacle shell with metal handle
 - Metal latch locking: Handle of receptacle and plug when mated
 - Better protection against splashwater
- **Contacts:**
 - High-quality, screw machine contacts
 - gold or silver plated
 - Crimp terminals
- **Flammability:**

Meets the requirements of UL94-V0 and the following fire-protection standards: EN 45545, NF F1610/2, NF F611030

Applications

EP Series







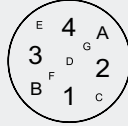

- **DMUs, EMUs, rail cars, and passenger coaches:**

Power and signal transfer for electropneumatic brakes as well as electropneumatic emergency brake override (EBO)
- **Freight wagons:**

Power and signal transfer for electropneumatic brakes

Specifications

EP Series

Connectors		EP Series		
Applicable standard		UIC 541-5 VE		
Contact arrangement and identification		 		
Rated voltage		250 V		
Contacts		Contact cavities	Wire gauge	Rated current
 		1, 2, 3, 4	AWG 7	35 A
 		A, B	AWG 9	25 A
 		C, E	AWG 18 ... 16	6 A
 		D	AWG 12	12 A
---		F, G	empty	---
Terminal type		Crimp		
Pilot contact		integrated in receptacle shell together with 1 S870 Series SPDT. 10 A (see catalogue D70e)		
Contact resistance (IEC 60512-2)		≤ 2 mΩ		
Operating temperature range		- 50 °C ... + 80 °C		
Degree of protection (IEC 60529)		IP69K when mated or receptacle closed		
Mechanical endurance (IEC 60512-5. test 9a)		> 10.000 mating cycles		
Materials				
Receptacle shell		Aluminium die-cast		
Plug shell		Polyamide PA 6.6, black		
Inserts		for plug and receptacle: Polyamide PA 6.6, black		
Seals		Silicone		
Contacts		Copper wrought alloy, crimpable		
Finish		Silver or gold plated		

Ordering code EP Series

● **EP plug:**

EP SK L3000

Series

EP

Connector type

- ST Plug
- SK Connector cable, single ended
- VK Connector cable, double ended

Cable length (connector type SK and VK only)

- L2000 Cable length 2000 mm
- L3000 Cable length 3000 mm
- L4500 Cable length 4500 mm

● **Accessories:**

EP A2

Series

EP

Type

- A1 Junction box with 11 pole terminal block
- A2 Junction box with 9 pole terminal block

● **EP receptacle:**

EP DK R1 S1 E1 Lxxxx

Series

EP

Connector type

- KD Receptacle
- BD Dummy receptacle
- DK Receptacle with connector cable

Backshell

- R0 none
- R1 with cable gland M40x1.5
- R2 with adapter Pg29
- R3 without adapter
- R4 made of metal

Pilot contact

- S0 none
- S1 with snap-action switch and terminal block

Drainage slots

- E0 none
- E1 existent

Cable length (connector type DK only)

- Lxxxx Cable length to customer requirements



Note:

Presented in this catalogue are only stock items.

For some connectors minimum order quantities apply.

Please contact us for terms and conditions.

Special variant:

If you need a special variant feel free to contact us. Maybe the type of connector you are looking for is among our many special designs. If not, we can also supply customized designs. In this case, however, minimum order quantities apply.

EP ST Plug, socket contacts included EP Series

● **Plug**

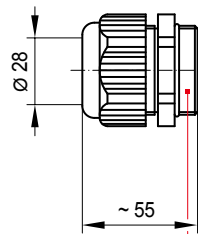
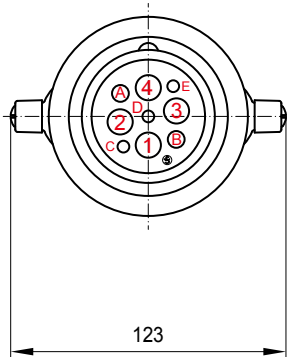

Cable gland M40x1.5 Fs sw with integrated strain relief

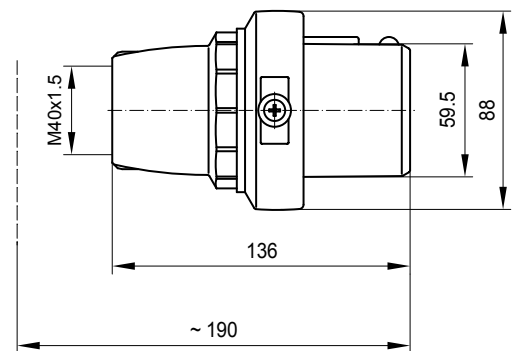

Total length including cable gland M40x1.5

EP KD Rx Sx Ex Receptacle, pin contacts included
EP BD Rx Sx Ex Dummy receptacle, 1 pin contact for feedback included

EP Series

- **EP KD R0 Sx Ex** Receptacle without backshell
 - **EP BD R0 Sx Ex** Dummy receptacle without backshell
- Device outline type R0

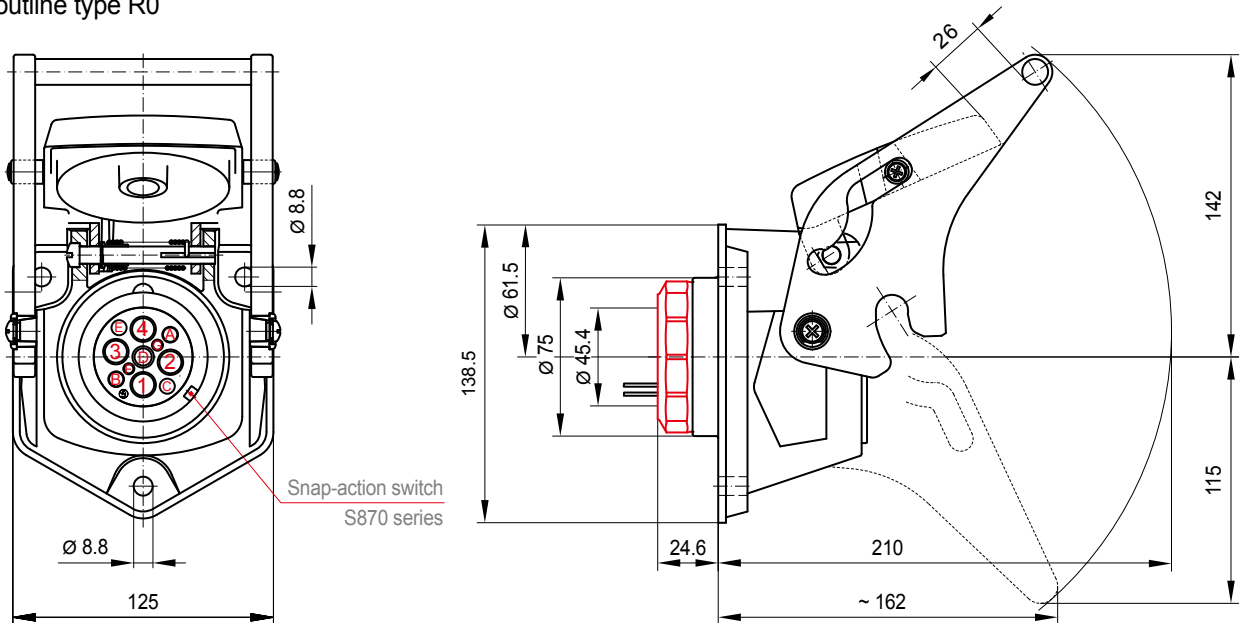

- **EP KD R1 Sx Ex** Receptacle with backshell and cable gland M40x1.5
- **EP BD R1 Sx Ex** Dummy receptacle with backshell and cable gland M40x1.5

Device outline type R1

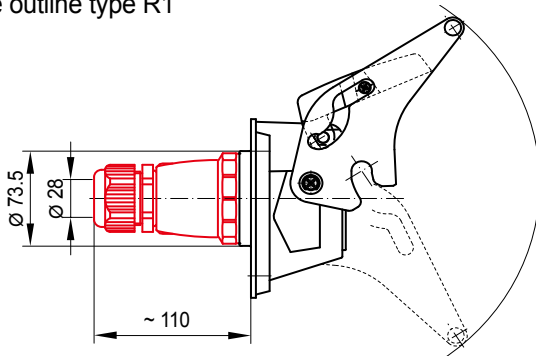

- **EP KD R2 Sx Ex** Receptacle with backshell and adapter Pg29
- **EP BD R2 Sx Ex** Dummy receptacle with backshell and adapter Pg29

Device outline type R2

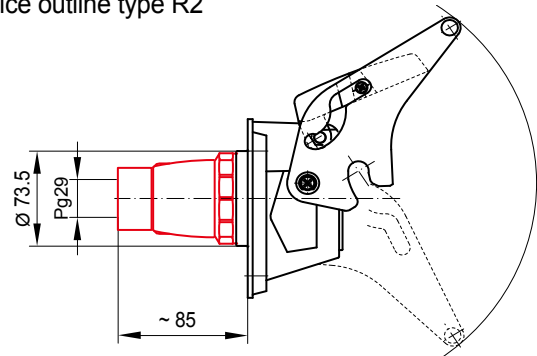

- **EP KD R3 Sx Ex** Receptacle with backshell without adapter
- **EP BD R3 Sx Ex** Dummy receptacle with backshell without adapter

Device outline type R3

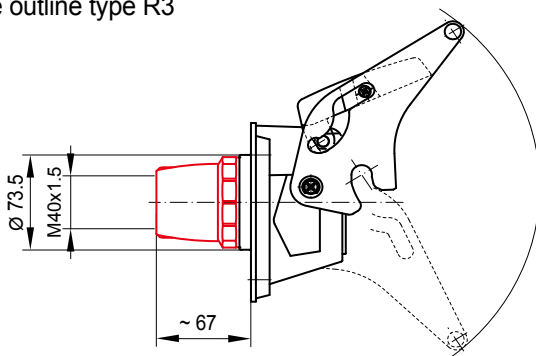

- **EP KD R4 Sx Ex** Receptacle with metal backshell
- **EP BD R4 Sx Ex** Dummy receptacle with metal backshell

Device outline type R4

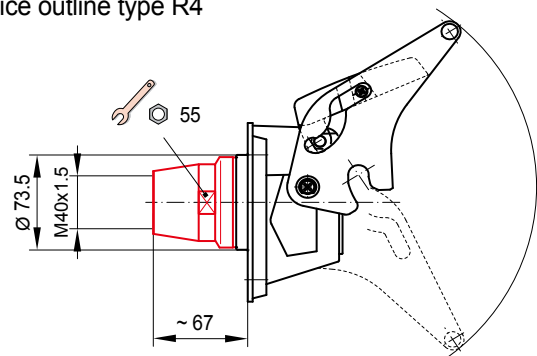

Contacts Crimp contacts (pin/socket)

EP Series

● **Ordering code contacts**

Contacts

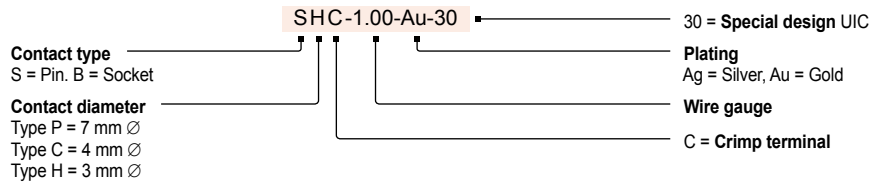

● **Crimp contacts for cavities 1, 2, 3, 4**

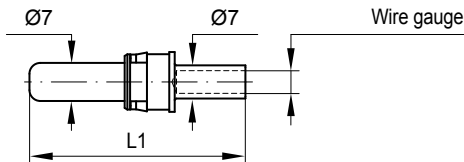

Ordering code	L1	Pin contact
SPC-10.0-Ag	39.7	for receptacle
SPC-2.5-Ag *	39.7	for dummy

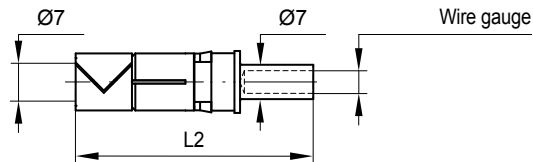

Ordering code	L2	Socket contact
BPC-10.0-Ag	42.2	for plug

Wire gauge	Rated current
AWG 7 (10 mm ²)	35 A
AWG 12 (2.5 mm ²)	12 A

* For feedback signalling end of train only one pin contact is implemented in contact cavity 4 of a dummy receptacle

● **Crimp contacts for cavities A, B**

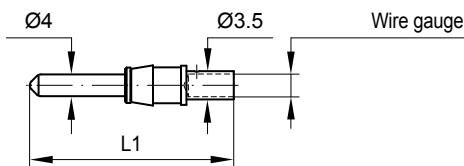

Ordering code	L1	Pin contact
SCC-6.00-Ag	37.5	for receptacle

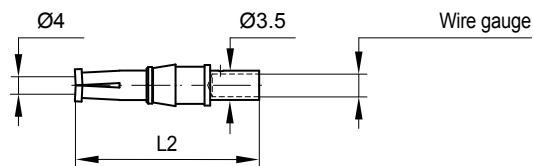

Ordering code	L1	Socket contact
BCC-6.00-Ag	32.6	for plug

Wire gauge	Rated current
AWG 9 (6 mm ²)	25 A

● **Crimp contacts for cavities C, E**

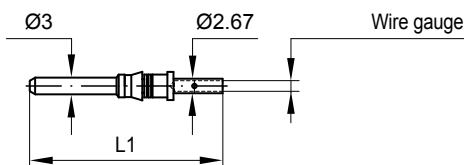

Ordering code	L1	Pin contact
SHC-1.00-Au-30	35.5	for receptacle

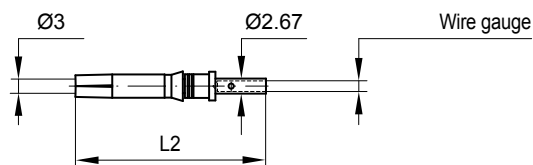

Ordering code	L1	Socket contact
BHC-1.00-Au-30	33.8	for plug

Wire gauge	Rated current
AWG 16 (1 mm ²)	6 A

● **Crimp contacts for cavity D**

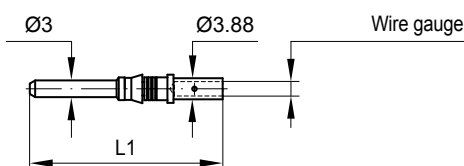

Ordering code	L1	Pin contact
SHC-2.50-Au-30	35.5	for receptacle

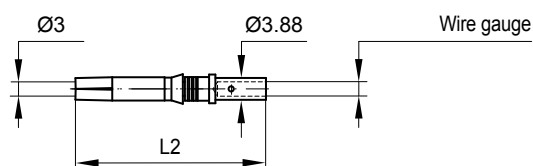

Ordering code	L1	Socket contact
BHC-2.50-Au-30	33.8	for plug

Wire gauge	Rated current
AWG 12 (2.5 mm ²)	6 A

Pre-assembled cables

- **EP VK Lxxxx** Connector cable. double ended

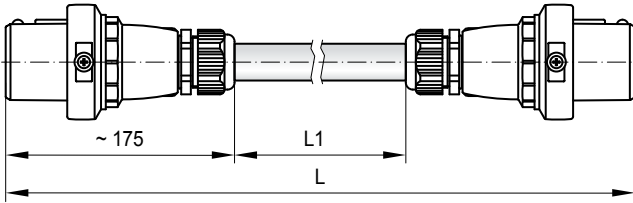

Ordering code	Total length L	Length L1
EP VK L2000	2000 mm ± 10	1650 mm
EP VK L3000	3000 mm ± 10	2650 mm
EP VK L4500	4500 mm ± 10	4150 mm

- **EP SK Lxxxx** Connector cable. single ended

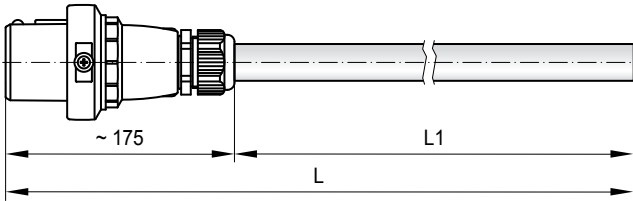

Ordering code	Total length L	Length L1
EP SK L2000	2000 mm ± 10	1825 mm
EP SK L3000	3000 mm ± 10	2825 mm
EP SK L4500	4500 mm ± 10	4325 mm

- **EP DK Rx Sx Ex Lxxxx** Receptacle with connector cable
Options see ordering code page 3
Length on request

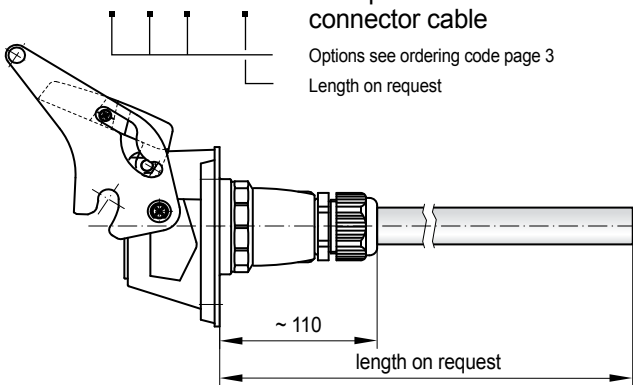

Tools

- **CWZ-120** Crimp tools for contacts Type P



Fig. similar

Ordering code	Description
CWZ-120	Crimp tool for wire gauges AWG 7 ... 250 MCM (10 mm ² ... 120 mm ²), contacts Type P

- **CWZ-600-1** Crimp tools for contacts Type C and H



Fig. similar

Ordering code	Description
CWZ-600-1	Crimp tool for wire gauges AWG 25 ... 9 (0.14 mm ² ... 6 mm ²), contacts Type C and H

- **AWZ-P, AWZ-C/H, AWZ-B** Extraction tools



Fig. similar

Ordering code	Description
AWZ-P	Extraction tool for contacts, contact insert cavities 1, 2, 3, 4
AWZ-C/H	Extraction tool for contacts, contact insert cavities A, B
AWZ-B	Extraction tool for contacts, contact insert cavities C, D, E

EP A1, EP A2 Cable junction box

Accessories

- **Cable junction box**

Junction box for holding a pre-assembled connector cable such as EP DK R1 S1 E1 L3000.

The following variants are available:

Ordering code	Description
EP A1	Junction box with 11 pole terminal block for receptacles with pilot contact (S1)
EP A2	Junction box with 9 pole terminal block for receptacles without pilot contact (S0)

Mounting: To be mounted via 4 M10 screws at the bottom of the box, see dimension diagram.

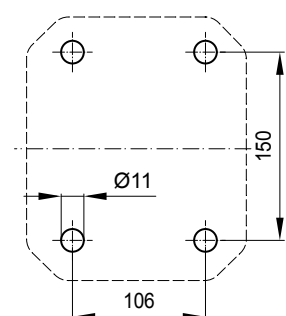
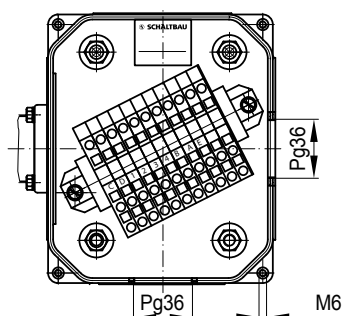
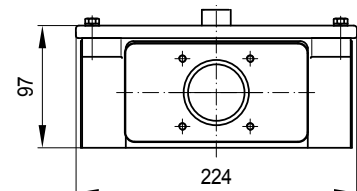
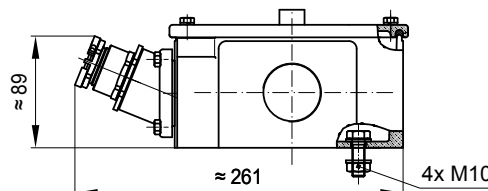

Assembly Plug and receptacle

EP Series

Assembly of plugs

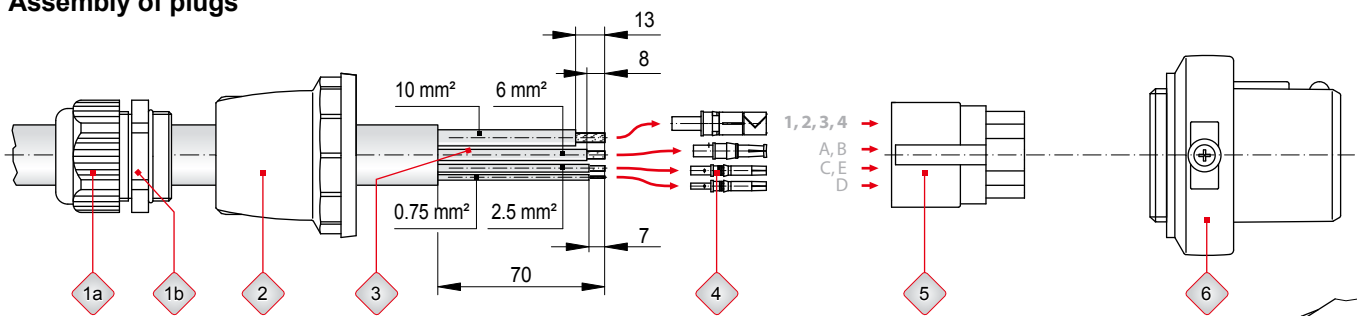

Assembly of receptacles

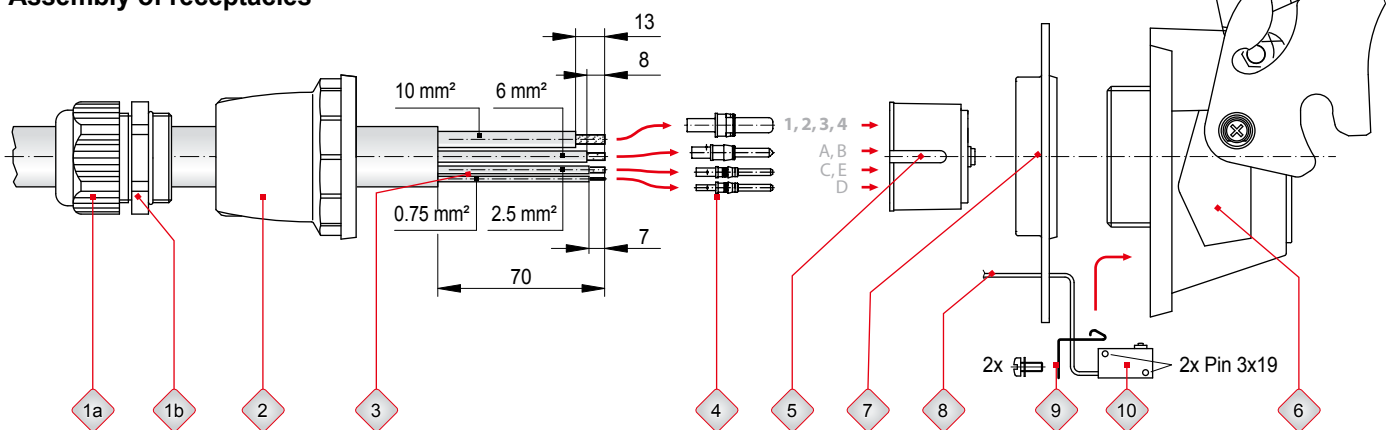

Assembly instructions

Place cable gland with integrated strain relief **1a**, **1b** and backshell **2** on cable in sequence shown. Remove part of cable jacket, trim the individual conductors **3** to the desired length and strip the insulation. Crimp cable conductors **3** to contacts **4**. The edge of the insulation where the wire is stripped should abut on the point of crimping.

Fit crimped contacts **4** into contact insert **5**. Make sure that clip is locked in place in contact insert. We recommend checking of the established contact. The contact retention test force is 40 N. Fit contact insert **5** into shell **6** and screw

backshell **2** to plug and receptacle shell **6** respectively. Screw part **1b** of cable gland in backshell **2** and tighten part **1a** of cable gland securely to ensure strain relief of individual conductors (depends on type of backshell; this instruction refers to R1).

Instructions to be continued for receptacle: Mount snap-action switch **10** together with accessories **9** in receptacle and connect leads **8**. Note: Make sure to secure the leads with sleeves! Press seal **7** to shell and mount receptacle and dummy receptacle respectively.

Mounting

EP Series

Please observe the following instructions:

- Metal plate must be earthed
- Surface finish of metal plate: Rz 6.3 ... 12.5 µm
- Terminal block for pilot contact: wire gauge 2.5 mm² max.
- Earth connection via mounting holes
- Tightening torque 15 Nm min.
- Mounting position: horizontal up to - 30°

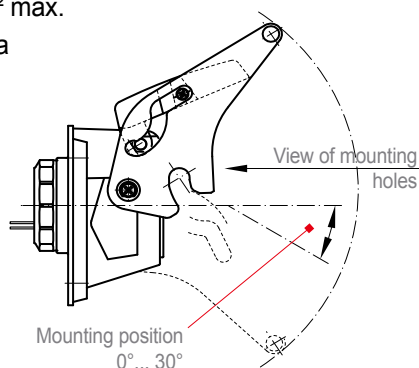

Mounting holes of receptacle and dummy receptacle:

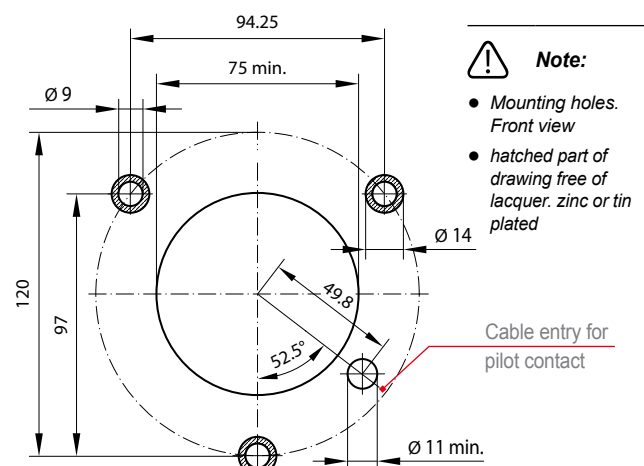

- Note:**
- Mounting holes. Front view
 - hatched part of drawing free of lacquer, zinc or tin plated

Cable entry for pilot contact



Schaltbau GmbH manufactures in compliance with RoHS.



The production facilities of Schaltbau GmbH have been IRIS certified since 2008.



Certified to DIN EN ISO 14001 since 2002. For the most recent certificate visit our website.



Certified to DIN EN ISO 9001 since 1994. For the most recent certificate visit our website.

Electrical Components and Systems for Railway Engineering and Industrial Applications

Connectors

- Connectors manufactured to industry standards
- Connectors to suit the special requirements of communications engineering (MIL connectors)
- Charging connectors for battery-powered machines and systems
- Connectors for railway engineering, including UIC connectors
- Special connectors to suit customer requirements

Snap-action switches

- Snap-action switches with positive opening operation
- Snap-action switches with self-cleaning contacts
- Enabling switches
- Special switches to suit customer requirements

Contactors

- Single and multi-pole DC contactors
- High-voltage AC/DC contactors
- Contactors for battery powered vehicles and power supplies
- Contactors for railway applications
- Terminal bolts and fuse holders
- DC emergency stop switches
- Special contactors to suit customer requirements

Control devices

- Master controllers and reversers for railway applications
- Toggle switch devices
- Handles and foot switches for railway applications (dead-man equipment)
- Switching elements with high breaking capacity
- Emergency brake handles
- Signal devices

Transportation system equipment

- Power supplies for passenger coaches (electric equipment)
- Battery chargers for locomotives and passenger coaches
- High-voltage equipment for single and multi-phase operation
- Heating devices and heating controls
- Design and engineering services for high-voltage equipment
- Special equipment to suit customer requirements

Schaltbau GmbH

Hollerithstrasse 5
81829 Munich
Germany

Phone +49 89 9 30 05-0
Fax +49 89 9 30 05-350
e-Mail contact@schaltbau.de
Internet www.schaltbau.de

with compliments: