

Industrial Grade Gyroscopes

ASC 271 | ASC 273

Uniaxial, Triaxial
 MEMS Vibrating Ring
 Measurement Range: ± 75 to ± 900 °/s
 Bias Stability: 12 °/hr
 Angular Random Walk: 0.2 °/√hr
 Aluminum Housing
Made in Germany



Industrial Grade Gyroscopes

The key components in industrial grade gyroscopes are high-quality micro-electro-mechanical systems (MEMS) that feature excellent long-term stability and reliability. The design of the micro-mechanical silicon structures makes the gyroscopes extremely insensitive to external impacts and vibrations. They are therefore ideal suited for use in harsh environmental conditions. Due to their high performance, the gyroscopes fulfill the requirements of industrial grade applications with respect to the maximum achievable precision.

Description

The gyroscopes of types ASC 271 and ASC 273 are based on proven MEMS vibrating ring sensor elements. The integrated electronic circuitry enables a single-ended, analog voltage output (0.66 to 2.64 V FSO) and flexible power supply voltage from 5 to 40 VDC. The industrial grade gyroscopes are available in four measurement ranges (75 °/s to 900 °/s) and providing a bias stability of 12 °/hr and an angular random walk of 0.2 °/√hr.

The uniaxial gyroscopes ASC 271 and triaxial gyroscopes ASC 273 feature a lightweight, reliable aluminum housing and an integrated cable with configurable length and connectors. Furthermore, the ASC 271 provides a protection class IP65 while the ASC 273 provides a protection class IP67.

Ideal applications are dynamic roll, pitch and yaw angle measurements in motor vehicles, ships and aircraft, as well as monitoring of vehicle dynamics in AGVs (automated guided vehicles) or the orientation of UAVs (unmanned aerial vehicles) in smart agriculture.

Features

- Industrial Grade Gyroscope
- Low Noise Analog Voltage Output Signal
- High Bias Stability
- Low Angular Random Walk
- Excellent Shock and Vibration Resistance

Options

- Customized Cable Length
- Customized Connector

Applications

- Vehicle Dynamics of AGV/UAV
- Track Geometry in Rail Transport Applications
- Camera, Antenna and Platform Stabilization Systems

More applications in several markets are figured out on our web page www.asc-sensors.de

ASC 271
(Uniaxial)

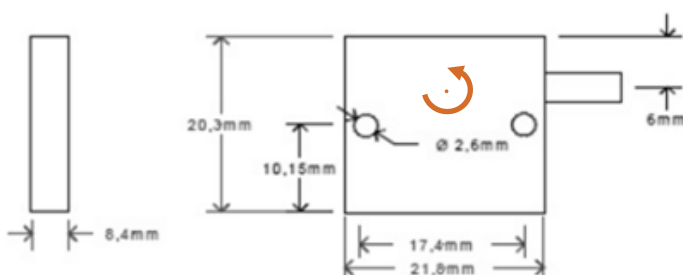

ASC 273
(Triaxial)

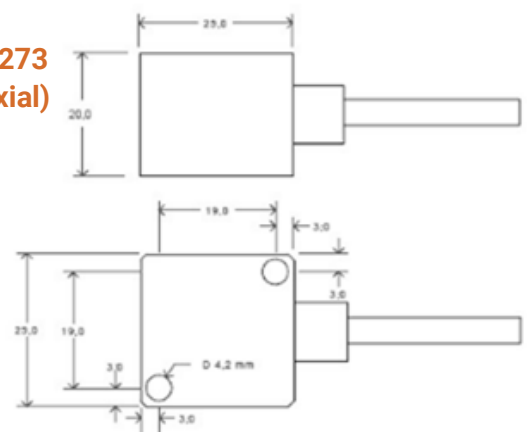

Typical Specification

Dynamic

Measurement Range	°/s	±75	±150	±300	±900
Scale Factor (sensitivity)	mV/°/s	13.2	6.6	3.3	1.1
Rate Noise Density	°/s/√Hz	0.018 (typ) 0.025 (max)			
Bandwidth (±3 dB)	Hz	150			
Amplitude Non-Linearity	% FSO	<0.06 (typ) <0.15 (max)			
Bias Stability	°/hr	12			
Angular Random Walk	°/√hr	0.2			

Electrical

Power Supply Voltage	V	5 to 40			
Operating Current Consumption	mA	ASC 271: 6 (13 during start-up) ASC 273: 18 (40 during start-up)			
Offset (bias)	V	1.65 ± 0.08			
Isolation		Case Isolated			

Environmental

Scale Factor Error over Temperature Range	%	±0.5 (typ) ±1.5 (max)			
Offset (bias) Error over Temperature Range	°/s	±1.0 (typ) ±3.0 (max)			
Operating Temperature Range	°C	-40 to +85			
Storage Temperature Range	°C	-40 to +100			
Shock Limit (operating, 1 ms)	g	500			
Shock Limit (survival, 0.1 ms)	g	10000			
Vibration induced Noise	°/s/g ²	0.060 (typ) 0.072 (max)			
Vibration Rectification Error	°/s/g ²	0.001 (typ) 0.003 (max)			
g-Sensitivity	°/s/g	0.080 (typ) 0.200 (max)			
Protection Class		ASC 271: IP 65 ASC 273: IP 67			

Physical

Sensing Element	MEMS Vibrating Ring				
Case Material	Anodized Aluminum				
Connector at Cable End	Optional				
Mounting	Adhesive Screw Holes				
Weight (without cable)	gram	ASC 271: 10 ASC 273: 35			
Cable for uniaxial ASC 271	13 gram per meter AWG 30 Polyurethane (PUR) Diameter 3.0 mm				
Cable for triaxial ASC 273	19 gram per meter AWG 30 Polyurethane (PUR) Diameter 4.5 mm				

Sensor Calibration

Factory Calibration (supplied with the sensor)

Part Number	#14288	#14288	#14288	#14288	#14289	#14289	#14289	#14289	
Number of sensitive Directions	ASC 271: uniaxial				ASC 273: triaxial				
Measurement Range (sensor)	°/s	±75	±150	±300	±900	±75	±150	±300	±900
Applied Frequency (min)	Hz	1	1	1	1	1	1	1	1
Applied Frequency (max)	Hz	100	100	100	100	100	100	100	100
Input Amplitude	°/s	35	75	150	450	35	75	150	450
Reference Frequency for Determination of Scale Factor	Hz	16	16	16	16	16	16	16	16

Calibration according DIN ISO 17025 (order separately)

Part Number	#16174	#16174	#16174	#16174	#16175	#16175	#16175	#16175	
Number of sensitive Directions	ASC 271: uniaxial				ASC 273: triaxial				
Measurement Range (sensor)	°/s	±75	±150	±300	±900	±75	±150	±300	±900
Applied Frequency (min)	Hz	1	1	1	1	1	1	1	1
Applied Frequency (max)	Hz	100	100	100	100	100	100	100	100
Input Amplitude	°/s	35	75	150	450	35	75	150	450
Reference Frequency for Determination of Scale Factor	Hz	16	16	16	16	16	16	16	16

Please note: If any other calibration procedure is required, don't hesitate to contact us. Furthermore, sensors have to be calibrated regularly to ensure accurate and precise results. Our services include both factory calibration and calibration in accordance with DAkkS guidelines. On request we will be glad to remind you of the next scheduled calibration of your sensors.

ASC 271: Cable Code / Pin Configuration (3 Wire System)

Pin	Color Code	Description
1	Supply +	Red Power supply voltage +5 to +40 VDC
2	Supply -	Black Power GND
3	Signal	Green Single-ended analog output voltage signal

ASC 273: Cable Code / Pin Configuration (9 Wire System) including separate Power Supply for all Axes

Pin	Color Code	Description
1	Supply +	Red/Violet X-Axis: power supply voltage +5 to +40 VDC
2	Supply -	Black/Violet X-Axis: power GND
3	Signal	Green/Violet X-Axis: single-ended analog output voltage signal
4	Supply +	Red/Grey Y-Axis: power supply voltage +5 to +40 VDC
5	Supply -	Black/Grey Y-Axis: power GND
6	Signal	Green/Grey Y-Axis: single-ended analog output voltage signal
7	Supply +	Red Z-Axis: power supply voltage +5 to +40 VDC
8	Supply -	Black Z-Axis: power GND
9	Signal	Green Z-Axis: single-ended analog output voltage signal

ASC 273: Cable Configuration

9 Wire System - 9L

Separate power supply for all axes, no cable switch



9 Wire System - 9L3

Separate power supply for all axes, including cable switch

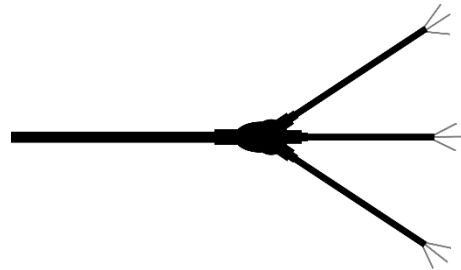

Ordering Information

Series	Model	- Range [g]	- Cable Length [m]	Connector & Pinout
ASC 27	1 (uniaxial)	075	6	A
		150		
		300		
		900		

Example:

ASC 271-075-6A

Series	Model	- Range [g]	- Cable Length [m]	Connector & Pinout	- Cable Configuration
ASC 27	3 (triaxial)	075	6	A	9L
		150			9L3
		300			
		900			

Example:

ASC 273-075-6A-9L

Ordering information are based on standard configurations. All customized versions regarding connector and/or pinout will lead to a corresponding product match code:

- Standard length of the integrated cable is 6 meters. However, different customized cable lengths are possible on request.
- Standard version has no connector at the cable end which is identified by "A" in the product match code. However, it is possible to assemble almost all connector types during production.
- Different cable configurations are only available for the triaxial gyroscope ASC 273.

Industrial Grade Gyroscopes

Safety Precaution for Installing and Operating

This data sheet is a part of the product. Read the data sheet carefully before using the product and keep it available for future operation. Handling, electrical connections, mounting or any other work performed at the sensor must be carried out by authorized experts only. Appropriate safety precautions must be taken to exclude any risk of personal injury and damage to operating equipment as a result of a sensor malfunction.

Handling

The sensor is packaged in a reliable housing to protect the sensing elements and integrated electronic components from the ambient environment. However, poor handling of the product can lead to damages that may not be visible and cause electrical failure or reliability issues. Handle the component with caution:

- Avoid shocks and impacts on the housing, such as dropping the sensor on hard surface
- Never move the sensor by pulling the cable
- Make sure that the sensor is used within the specified environmental conditions
- Transport and store the sensor in its original or similar packaging
- The sensor should be mounted on a stable flat surface with all screws tightened or other mounting options
- Avoid any deformation during mounting the sensor
- Mounting tolerances may have an influence on the measured result

Electrical

ASC's inertial sensors are working with many established data acquisition systems. However, make sure that a proper DAQ is used, for the corresponding operation principle of the sensor. Furthermore, suitable precautions shall be employed during all phases of shipment, handling and operating:

- Active sensor pins are susceptible to damage due to electrostatic discharge (ESD)
- Make sure that the sensor is used within the specified electrical conditions
- Check all electrical connections prior to initial setup of the sensor
- Completely shield the sensor and connecting cable
- Do not perform any electrical modifications at the sensor
- Do not perform any adaptations on the wiring or connectors while the device under power
- Never plug or unplug the electrical connection while the sensor is under power
- When a certain pin is not used during operation, make sure that the pin is insulated

Quality

- We have a quality management system according to ISO 9001:2015.
- The Deutsche Akkreditierungsstelle GmbH (DAkkS) has awarded to our calibration laboratory the DIN EN ISO/IEC 17025:2018 accreditation for calibrations and has confirmed our competence to perform calibrations in the field of mechanical acceleration measurements. The registration number of the certificate is **D-K-18110-01-00**.
- All ASC products are **CE**-compliant.

Made in Germany



analyzing



monitoring



testing



measuring