

EM3-CT Series

Three Phase Multifunction Energy Meter



DIN RAIL SMART METER FOR SINGLE AND THREE PHASE ELECTRICAL SYSTEMS

User Manual v4.4

1. Introduction

This document provides operating, maintenance and installation instructions. This unit measures and displays the characteristics of single phase two wires(1p2w), three phase three wires(3p3w) and three phase four wires(3p4w) networks. The measuring parameters include voltage(V), frequency(Hz), current(A), power(kW/Kva/Kvar), import, export and total Energy(kWh/kVarh). The unit can also measure Maximum demand current and power, this is measured over preset periods of up to 60 minutes.

This unit is a 1A or 5A current transformer operated and can be configured to work with a wide range of CTs. Built-in pulse and Modbus or M-Bus outputs. Configuration is password protected.

This unit can be powered from a separate auxiliary (AC or DC) supply. Alternatively it can be powered from the monitored supply by linking the voltage reference and neutral reference in to terminals 5 and 6 (Please refer to wiring diagram).

1.1 Unit Characteristics

The Unit can measure and display:

- Voltage and THD% (total harmonic distortion) of all phases
- Line frequency
- Currents, current demand and current THD% of all phases
- Power, maximum power demand and power factor
- Active energy imported and exported
- Reactive energy imported and exported

This series includes 3 models:

EM3-CT-Modbus	EM3-CT-Mbus	EM3-CT-Modbus-T2
Multi-parameter measurement	Multi-parameter measurement	Multi-parameter measurement
Single Tariff 1A/5A CT operated	Single Tariff 1A/5A CT operated	Double Tariff 1A/5A CT operated
Rs485 Port Modbus RTU	M-Bus Communication	Rs485 Port Modbus RTU
Bi-directional energy	Bi-directional energy	Bi-directional energy

1.2 Current Transformer Primary Current

EM3-CT Series is CT operated. you will need to set the correct ratio.

As an example: If using 100/5A CT, you will need to insure CT2 (Secondary) is set to 5 and CT rate is 0020. You divide the primary by the secondary to get the CT rate to be entered (100/5=20).

1.3 RS485 Modbus RTU / M-Bus

EM3-CT-Modbus and EM3-CT-Modbus-T2 both meter have a Rs485 port with Modbus RTU protocol. EM3-CT-Mbus has a M-Bus port complying with EN13757-3. Rs485 or M-Bus provide a means of remotely monitoring and controlling the unit. Set-up screens are provided for setting up the communication port.

1.4 Pulse output

Two pulse outputs that pulse measured active and reactive energy. The Pulse 2 constant for active energy is 3200imp/kWh. (Terminals 11 & 12) The pulse width for Pulse 1 can be set from the set-up menu (Terminals 9 & 10).

2. Start Up Screens

	The first screen lights up all display segments and can be used as a display check.
	Software version information
	The interface performs a self-test and indicates the result if the test passes.

*After a short delay, the screen will display active energy measurements.

3. Measurements

The buttons operate as follows:

	Selects the Voltage and Current display screens. In Set-up Mode, this is the "Left" or "Back" button.
	Select the Frequency and Power factor display screens. In Set-up Mode, this is the "Up" button.
	Select the Power display screens. In Set-up Mode, this is the "Down" button.
	Select the Energy display screens. In Set-up mode, this is the "Enter" or "Right" button.

3.1 Voltage and Current

Each successive press of the button selects a new parameter:

	Phase to neutral voltages.
	Current on each phase.
	Phase to neutral voltage THD%.
	Current THD% for each phase.

3.2 Frequency and Power Factor and Demand

Each successive press of the button selects a new range:

	Frequency and Power Factor (total).
	Power Factor of each phase.
	Maximum Power Demand.
	Maximum Current Demand.

3.3 Power

Each successive press of the button select a new range:

	Instantaneous Active Power in kW.
	Instantaneous Reactive Power in kVar.
	Instantaneous Volt-Amps in kVA.
	Total kW, kVarh, kVA.

3.4 Energy Measurements

Each successive press of the button selects a new range:

	Import active energy in kWh.
	Export active energy in kWh.
	Import reactive energy in kVarh.
	Export reactive energy in kVarh.
	Total active energy in kWh.
	Total reactive energy in kVarh.

	T1 active energy in kWh
	T2 active energy in kWh
	T1 reactive energy in kVarh
	T2 reactive energy in kVarh

4. Set Up

To enter set-up mode, press the button for 3 seconds, until the password screen appears.

	Setting up is password-protected so you must enter the correct password (default '1000') before processing.
	If an incorrect password is entered, the display will show: PASS Err

To exit setting-up mode, press repeatedly until the measurement screen is restored.

4.1 Set-up Entry Methods

Some menu items, such as password and CT, require a four-digit number entry while others, such as supply system, require selection from a number of menu options.

4.1.1 Menu Option Selection

1. Use the and buttons to scroll through the different options of the set up menu.
2. Press to confirm your selection
3. If an item flashes, then it can be adjusted by the and buttons.
4. Having selected an option from the current layer, press to confirm your selection. The SET indicator will appear.
5. Having completed a parameter setting, press to return to a higher menu level. The SET indicator will be removed and you will be able to use the and buttons for further menu selection.
6. On completion of all setting-up, press repeatedly until the measurement screen is restored.

4.1.2 Number Entry Procedure

When Setting up the unit, some screens require the entering of a number. In particular, on entry to the setting up section, a password must be entered. Digits are set individually, from left to right. The procedure is as follows:

1. The current digit to be set flashes and is set using the and buttons
2. Press to confirm each digit setting. The SET indicator appears after the last digit has been set.
3. After setting the last digit, press to exit the number setting routine. The SET indicator will be removed.

4.2 Change Password

	Use the and buttons to choose the change password option.
	Press the to enter the change password routine. The new password screen will appear with the first digit flashing.
	Use and to set the first digit and press to confirm your selection. The next digit will flash.
	Repeat the procedure for the remaining three digits.
	After setting the last digit, SET will show.

Press to exit the number setting routine and return to the Set-up menu. SET will be removed

4.3 DIT Demand Integration Time

This sets the period in minutes over which the current and power readings are integrated for maximum demand measurement. The options are: off, 5, 10, 15, 30, 60 minutes.

	From the set-up menu, use and buttons to select the DIT option. The screen will show the currently selected integration time.
	Press to enter the selection routine. The current time interval will flash.
	Use and buttons to select the time required.
	Press to confirm the selection. SET indicator will appear.

Press to exit the DIT selection routine and return to the menu.

Warnings

Important Safety Information is contained in the Maintenance section. Familiarize yourself with this information before attempting installation or other procedures. Symbols used in this document:

- Risk of Danger: These instructions contain important safety information. Read them before starting installation or servicing of the equipment.
- Caution: Risk of Electric Shock

4.4 Supply System

The unit has a default setting of 3Phase 4wire (3P4). Use this section to set the type of electrical system.

	From the set-up menu, use and buttons to select the system option. The screen will show the currently selected power supply.
	Press to enter the selection routine. The current selection will flash.
	Use and buttons to select the required system option: 1P2(W), 3P3(W), 3P4(W).
	Press to confirm the selection. SET indicator will appear.

Press to exit the system selection routine and return to the menu. SET will disappear and you will be returned to the main set-up menu.

4.5 CT

The CT option sets the secondary current (CT2 1A or 5A) of the current transformer (CT) that wires to the meter.

	From the set-up menu, use and buttons to select the CT option.
	Secondary CT setting Press to enter the CT secondary current selection routine.:5A/1A
	Set CT Ratio value Press to enter the CT Ratio setting screen. The range is from 0001 to 9999.

For example, if using a 100/5A current transformer you will enter 0020, as you need to divide the primary by the secondary to get the ratio (CT rate).

* Please note for the MID approved version device, you will only have one opportunity to set the ratio.

4.6 PT

The PT option sets the secondary voltage (PT2 100 to 500V) of the voltage transformer (PT) that may be connected to the meter.

	Use and buttons to select the PT option. The screen will show the voltage PT secondary voltage value. The default value is 400V.
	Secondary PT setting Press to enter the PT secondary voltage selection routine. The range is from 100 to 500V.
	Set PT ratios value Press to enter the PT ratio screen. The range is from 0001 to 9999.

For example, if set the ratio to be 100, it means the primary voltage equals secondary voltage x100.

4.7 Pulse Output

This option allows you to configure the pulse output. The output can be set to provide a pulse for a defined amount of energy active or reactive. Use this section to set up the relay pulse output—Units: kWh, kVAh

	From the set-up menu, use NOI/PFNZ and P buttons to select the Pulse output option.
	Press E to enter the selection routine. The unit symbol will flash.
	Use NOI/PFNZ and P buttons to choose kWh or kVAh.

On completion of the entry procedure, press **E** to confirm the setting and press **V/A ESC** to return to the main set up menu.

4.7.1 Pulse rate

Use this to set the energy represented by each pulse. Rate can be set to 1 pulse per 0.01kWh/0.1kWh/1kWh/10kWh/100kWh.

	(It shows 1 impulse = 10kWh/kVAh)
	From the set-up menu, use NOI/PFNZ and P buttons to select the Pulse Rate option.
	Press E to enter the selection routine. The current setting will flash.
	Use NOI/PFNZ and P buttons to choose pulse rate.

Use **NOI/PFNZ** and **P** buttons to choose pulse rate. On completion of the entry procedure, press **E** to confirm the setting and press **V/A ESC** to return to the main set up menu.

4.7.2 Pulse Duration

The energy monitored can be active or reactive and the pulse width can be selected as 200, 100 or 60ms.

	(It shows pulse width of 200ms)
	From the set-up menu, use NOI/PFNZ and P buttons to select the Pulse width option.
	Press E to enter the selection routine. The current setting will flash.

Use **NOI/PFNZ** and **P** buttons to choose pulse width. On completion of the entry procedure press **E** to confirm the setting and press **V/A ESC** to return to the main set up menu.

4.8 Communication

There is a RS485 port can be used for communication using Modbus RTU protocol. For Modbus RTU, parameters are selected from Front panel.

4.8.1 RS485 Address

	(The range is from 001 to 247)
	From the set-up menu, use NOI/PFNZ and P buttons to select the address ID.
	Press E button to enter the selection routine. The current setting will be flashing.
	Use NOI/PFNZ and P buttons to choose Modbus address (001 to 247).

On completion of the entry procedure, press **E** button to confirm the setting and press **V/A ESC** button to return the main set-up menu.

4.8.2 M-Bus Address

	Primary address: 001 to 250 Use NOI/PFNZ and P buttons to select the address value.
	Press E to enter the selection routine. The current setting will flash.
	Secondary address: 00 00 00 01 to 99 99 99 99

On completion of the entry procedure, press **E** to confirm the setting and press **V/A ESC** to return to the main set up menu.

4.8.3 Baud Rate

	From the set-up menu, use NOI/PFNZ and P buttons to select the Baud Rate option.
	Press E to enter the selection routine. The current setting will flash.
	Use NOI/PFNZ and P buttons to choose Baud rate 2.4k, 4.8k, 9.6k, 19.2k, 38.4k

On completion of the entry procedure, press **E** to confirm the setting and press **V/A ESC** to return to the main set up menu.

4.8.4 Parity

	From the set-up menu, use NOI/PFNZ and P buttons to select the parity option.
	Press E to enter the selection routine. The current setting will flash.
	Use NOI/PFNZ and P buttons to choose parity (EVEN / ODD / NONE (default)).

On completion of the entry procedure, press **E** to confirm the setting and press **V/A ESC** to return to the main set up menu.

4.8.5 Stop bits

	From the set-up menu, use NOI/PFNZ and P buttons to select the stop bit option.
	Press E to enter the selection routine. The current setting will flash.
	Use NOI/PFNZ and P buttons to choose stop bit (2 or 1) Note: Default is 1, and only when the parity is NONE that the stop bit can be changed to 2.

On completion of the entry procedure, press **E** to confirm the setting and press **V/A ESC** to return to the main set up menu.

4.9 Backlit set-up

The meter provides a function to set the blue backlit lasting time(0/5/10/30/60/120 minutes).

Option 0 means the backlit always on here.

	Default:60 If it's setted as 5,the backlit will be off in 5minutes.
	Use NOI/PFNZ and P buttons to choose the time
	Press E to confirm the setting and press V/A ESC to return to the main set up menu.
	From the set-up menu, use NOI/PFNZ and P buttons to select the reset option.

4.10 CLR

The meter provides a function to reset the maximum demand value of current and power.

	Press E to enter the selection routine. The dlT will flash.
--	--

Press **E** to confirm the setting and press **V/A ESC** to return to the main set up menu.

5. Specifications

5.1 Measured Parameters

The unit can monitor and display the following parameters of a single phase two wire(1p2w), three phase three wire(3p3w) or three phase four wire(3p4w) system.

5.1.1 Voltage and Current

- Phase to neutral voltages 100 to 289V a.c. (not for 3p3w supplies).
- Voltages between phases 173 to 500V a.c. (3p supplies only).
- Percentage total voltage harmonic distortion (THD%) for each phase to N (not for 3p3w supplies).
- Percentage voltage THD% between phases (three phase supplies only).
- Current THD% for each phase

5.1.2 Power factor and Frequency and Max. Demand

- Frequency in Hz
- Instantaneous power:
- Power 0 to 3600 MW
- Reactive power 0 to 3600 MVAR
- Volt-amps 0 to 3600 MVA
- Maximum demanded power since last Demand reset
- Power factor
- Maximum neutral demand current, since the last Demand reset (for three phase supplies only)

5.1.3 Energy Measurements

- Import/Export active energy 0 to 9999999.9 kWh
- Import/Export reactive energy 0 to 9999999.9 kVAh
- Total active energy 0 to 9999999.9 kWh
- Total reactive energy 0 to 9999999.9 kVAh

5.2 Measured Inputs

Voltage inputs through 4-way fixed connector with 2.5mm² stranded wire capacity. single phase two wire(1p2w), three phase three wire(3p3w) or three phase four wire(3p4w) unbalanced. Line frequency measured from L1 voltage or L3 voltage.

Three current inputs (six physical terminals) with 2.5mm² stranded wire capacity for connection of external CTs. Nominal rated input current 5A or 1A a.c. Rms.

5.3 Accuracy

- Voltage 0.5% of range maximum
- Current 0.5% of nominal
- Frequency 0.2% of mid-frequency
- Power factor 1% of unity (0.01)
- Active power (W) ±1% of range maximum
- Reactive power (VAR) ±1% of range maximum
- Apparent power (VA) ±1% of range maximum
- Active energy (Wh) Class 1 IEC 62053-21
- Reactive energy (VAh) ±1% of range maximum
- Total harmonic distortion 1% up to 31st harmonic
- Response time to step input 1s, typical, to >99% of final reading, at 50 Hz.

5.4 Auxiliary Supply

Two-way fixed connector with 2.5mm² stranded wire capacity. 85 to 275V a.c. 50/60Hz ±10% or 120V to 380V d.c. ±20%. Consumption < 10W.

5.5 Interfaces for External Monitoring

Three interfaces are provided:

- RS485 communication channel that can be programmed for Modbus RTU protocol
- Relay output indicating real-time measured energy. (configurable)
- Pulse output 3200imp/kWh (not configurable)

The Modbus configuration (baud rate etc.) and the pulse relay output assignments (kWh/kVAh, import/export etc.) are configured through the set-up screens.

5.5.1 Pulse Output

The pulse output can be set to generate pulses to represent kWh or kVAh.

Rate can be set to generate 1 pulse per:

- 0.01 = 10 Wh/kVAh
- 0.1 = 100 Wh/kVAh
- 1 = 1 kWh/kVAh
- 10 = 10 kWh/kVAh
- 100 = 100 kWh/kVAh
- 1000 = 1000 kWh/kVAh

Pulse width 200/100/60 ms.

Relay Rating 240V ac 50mA

5.5.2 RS485 Output for Modbus RTU

For Modbus RTU, the following RS485 communication parameters can be configured from the set-up menu:

- Baud rate 2400, 4800, 9600, 19200, 38400
- Parity none (default) / odd / even
- Stop bits 1 or 2
- RS485 network address nnn – 3-digit number, 1 to 247

Modbus™ Word order Hi/Lo byte order is set automatically to normal or reverse. It cannot be configured from the set-up menu.

5.6 Reference Conditions of Influence Quantities

Influence Quantities are variables that affect measurement errors to a minor degree. Accuracy is verified under nominal value (within the specified tolerance) of these conditions.

- Ambient temperature 23°C ±1°C
- Input frequency 50 or 60Hz ±2%
- Input waveform Sinusoidal (distortion factor < 0.005)
- Auxiliary supply voltage Nominal ±1%
- Auxiliary supply frequency Nominal ±1%
- Auxiliary supply waveform (if AC) Sinusoidal (distortion factor < 0.05)
- Magnetic field of external origin Terrestrial flux

5.7 Environment

- Operating temperature -25°C to +55°C*
- Storage temperature -40°C to +70°C*
- Relative humidity 0 to 95%, non-condensing
- Altitude Up to 3000m
- Warm up time 1 minute
- Vibration 10Hz to 50Hz, IEC 60068-2-6, 2g
- Shock 30g in 3 planes

* Maximum operating and storage temperatures are in the context of typical daily and seasonal variation.

5.8 Mechanics

- DIN rail dimensions 72 x 94.5 mm (WxH) per DIN 43880
- Mounting DIN rail (DIN 43880)
- Sealing Ip51 (indoor)
- Material Self-extinguishing UL94 V-0

5.9 Declaration of Conformity(for the MID approved version meter only)

COMADAN A/S

Declare under our sole responsibility as the manufacturer that the poly phase multifunction electrical energy meter "EM3-CT" Series correspond to the production model described in the EC-type examination certificate and to the requirements of the Directive 2014/32/EU EC type examination certificate number 0120/SGS0327. Identification number of the NB0120

6. Dimensions

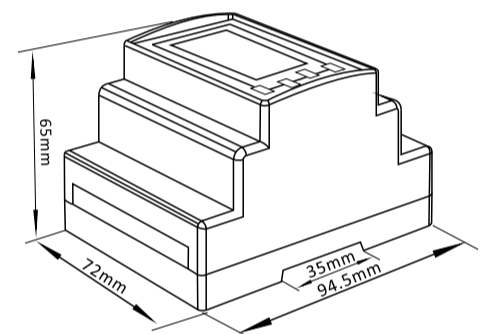

7. Installation

The wiring diagram of EM3-CT series has little difference from different models. please make sure the wiring is correct before turn on power of the meter.

current and Voltage inputs

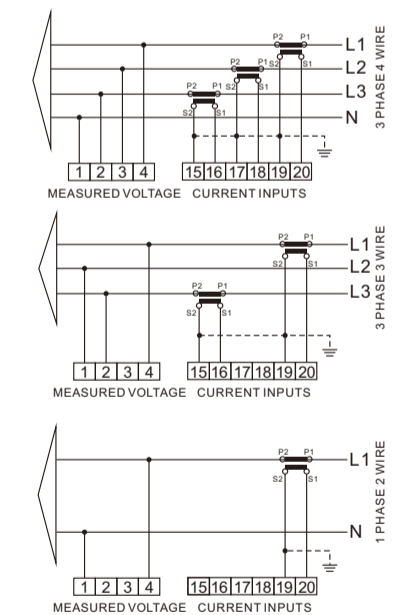

Definitions of other terminals

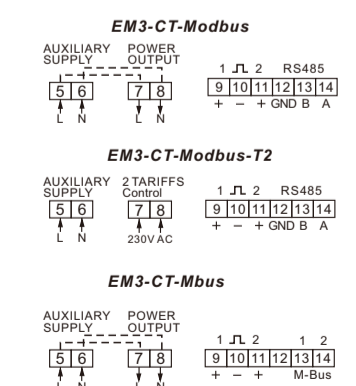

COMADAN A/S

Add: Messingvej 60, DK-8940, Randers SV, Denmark
Tell:+45 8644 7877
Email:sales@comadan.com
Web: www.comadan.com

