

Cascade LWP

Multi-Configurable Optical Probe for Photonic Device Characterization

➤ Overview

The LWP series of lightwave probes enable optical measurements for on-wafer and hybrid photonics devices. It features user-replaceable fiber pigtailed allowing the probe to be optimized for a variety of light delivery and light collection applications including the characterization of topside illuminated photodiodes, Vertical Cavity Surface Emitting Lasers (VCSELs), hybrid transmitters and receivers, and LEDs.

The LWP probe can illuminate and collect optical signals used in the characterization of a variety of photonic devices. When combined with FormFactor's probe stations and RF/DC probes, the LWP probe can provide modulation, spectral, time domain and low-level LIV measurements.

The choice of field-replaceable fiber pigtail depends on the required illumination pattern or collection efficiency. The fiber pigtailed are available as single-mode or multi-mode with either a lensed or cleaved end face. The lensed fiber pigtailed provide high numerical aperture (NA) illumination and collect light with extremely low back-reflection. The lensed single-mode fiber can provide an illumination area as small as 5 μm . The multi-mode pigtailed are well suited for high-efficiency collection of light.



➤ Features / Benefits

Flexibility and ease of use	<ul style="list-style-type: none">• Field-replaceable fibers optimized for a variety of applications• Wafer mapping capability and visual display of key parameters
Accuracy	<ul style="list-style-type: none">• Patented contact protection design ensures fast, accurate, and repeatable measurements at the wafer and substrate level• Minimized electrical parasitics for at-speed testing
Compatibility	<ul style="list-style-type: none">• Standard FC type fiber-optic connector• Compatible with FormFactor probe stations and accessories

Specifications

Fiber Type	Minimum Illumination Diameter	Wavelength	Numeric Aperture	Insertion Loss
Cleaved single-mode (CLV-SM)	25 μm	1300 nm, 1550 nm	0.13	0.5 dB
Cleaved multi-mode (CLV-MM)	100 μm	850 nm – 1550 nm	0.28	0.5 dB
Lensed single-mode (LEN-SM)	5 μm	1300 nm, 1550 nm	NA	0.5 dB
Lensed multi-mode (LEN-MM)	50 μm	850 nm – 1550 nm	NA	0.5 dB

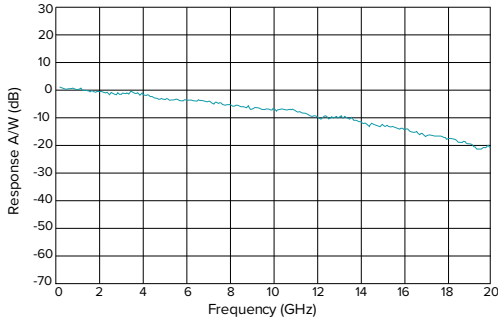

Responsivity measurement of an 80 μm photodiode using the LWP probe and the Agilent Technologies 83420A Lightwave Test Set.

Physical Dimensions

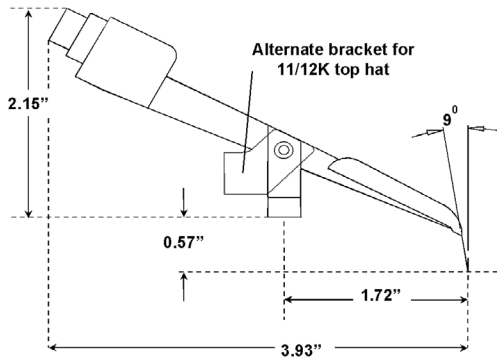

Ordering Information

	Probe* with Fiber		Replacement Fibers	
	Cleaved Fiber	Lensed Fiber	Cleaved Fiber	Lensed Fiber
Single mode	LWP-CLV-SM	LWP-LEN-SM	FT-CLV-SM	FT-LEN-SM
Multi mode	LWP-CLV-MM	LWP-LEN-MM	FT-CLV-MM	FT-LEN-MM

* Probe orders include two eyepiece filters for safe viewing of CDRH Class-1 laser sources for wavelengths of 800 nm -1550 nm. Alternate mounting bracket for use with Summit™ probe stations (AP/M models with MicroChamber®).

© Copyright 2018 FormFactor, Inc. All rights reserved.
FormFactor and the FormFactor logo are trademarks of FormFactor, Inc. All other trademarks are the property of their respective owners.

All information is subject to change without notice.

LWP-DS-0518