



RIFTEK

Sensors & Instruments



MULTISENSOR INNER DIAMETER MEASUREMENT SYSTEM

RF040-65/115 Series

User's manual

Contents

1. Safety precautions.....	3
2. CE compliance.....	3
3. Laser safety.....	3
4. General information.....	3
5. Basic technical data.....	4
6. Example of item designation when ordering.....	4
7. Structure and operational principle.....	4
8. Overall demands for mounting.....	5
9. Cables.....	5
9.1. Power cable.....	5
9.2. Ethernet cable.....	6
10. Network setting.....	6
11. Indended use.....	6
11.1. Preparation for use.....	6
11.1.1. Visual inspection.....	7
11.1.2. Installation and connection.....	7
11.1.3. Switching the system.....	7
11.1.4. Calibration.....	7
11.2. Operating the system.....	7
12. Service software.....	7
12.1. General information.....	7
12.2. System requirements.....	7
12.3. SDK library.....	7
12.4. RF040 Test Program.....	8
12.4.1. Connection.....	8
12.4.2. Calibration.....	8
12.4.3. Measurement.....	9
13. Warranty policy.....	9
14. List of changes.....	9
15. Distributors.....	9

1. Safety precautions

- Use supply voltage and interfaces indicated in the system specifications.
- In connection/disconnection of cables, the system power must be switched off.
- Do not use the system in locations close to powerful light sources.
- The system must be grounded.

2. CE compliance

The system has been developed for use in industry and meets the requirements of the following Directives:

- EU directive 2014/30/EU. Electromagnetic compatibility (EMC).
- EU directive 2011/65/EU, “RoHS” category 9.

3. Laser safety

The sensors make use of c.w. 660 nm wavelength semiconductor lasers. Maximum output power is 1 mW. The system belongs to the 2 laser safety class according to IEC/EN 60825-1:2014. The following warning label is placed on the system body:

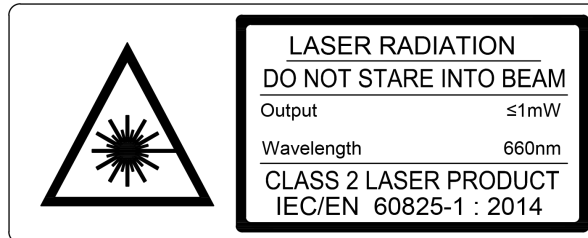

The following safety measures should be taken while operating the system:

- Do not target a laser beam to humans.
- Avoid staring into a laser beam.
- Do not disassemble the system.

4. General information

The system is designed for non-contact measuring of inner diameter of cylindrical and taper pipes, gun barrels. The system is used on the production line as the quality control tool.

5. Basic technical data

Parameter		Value
Diameter measurement range, mm		65...115
Measurement accuracy, μm		± 25
Light source		red semiconductor laser, 660 nm wavelength
Output power, mW		<1
Laser safety class		2 (IEC60825-1)
Output interface		Ethernet
Power supply, V		9...36
Power consumption, W		7
Environmental resistance	Enclosure rating	IP67
	Vibration	20 g / 10...1000 Hz, 6 hours for each of XYZ axes
	Shock	30 g / 6 ms
	Permissible ambient light, lx	30000
	Relative humidity, %	5-95 (no condensation)
	Operating ambient temperature, $^{\circ}\text{C}$	0...+45
	Storage temperature, $^{\circ}\text{C}$	-20...+70
Housing material		aluminum
Weight (without cable), gram		1000

NOTE. Technical characteristics of the system can be changed for a specific task.

6. Example of item designation when ordering

RF040-Dmin/Dmax

Symbol	Description
Dmin	Minimum measurement diameter, mm
Dmax	Maximum measurement diameter, mm

Example: RF040-65/115 – Multisensor Inner Diameter Measurement System RF040, measurement range - 65...115 mm

7. Structure and operational principle

Operation of the system is based on the hole surface coordinates measurement by point laser triangulation sensors.

The system contains 3-6 point laser triangulation sensors located circumferentially in one housing at known fixed angles (see Figure 1).

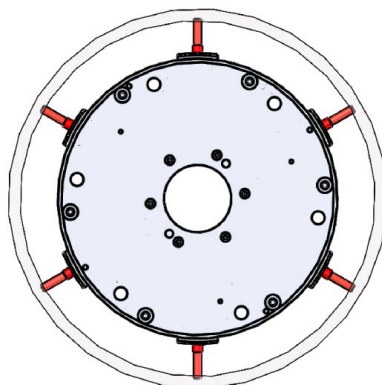

Figure 1. The system with six laser sensors

The system operates as follows.

The measurement system is inserted into the pipe and moved by translation module to the definite position. Laser sensors measure distances to the inner surface. Software calculates inner diameter of the pipe.

Overall and mounting dimensions are shown in Figure 2.

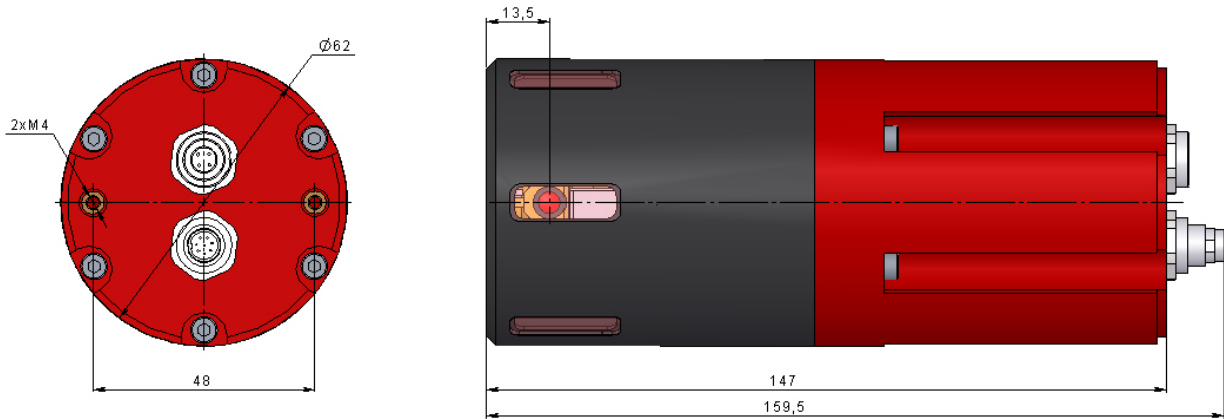

Figure 2. Overall and mounting dimensions

8. Overall demands for mounting

The system is positioned so that the object under control has to be placed within the working range of the system.



ATTENTION!

The system must be grounded – static electricity may cause the failure of electronic components.

9. Cables

9.1. Power cable

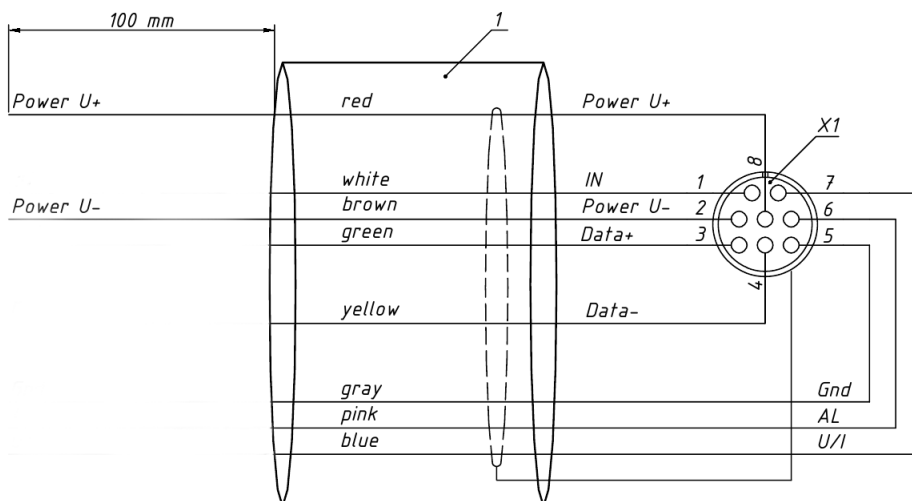

Designations:

X1	Binder 712 99 0426 10 08
1	Cable UNITRONIC LIYCY 8x0.14

Assignment:

Pin number	Assignment	Wire color	Note
8	Power U+	Red	Power supply: 9...36 V Power consumption: 7 W
2	Power U-	Brown	
1	IN	White	
3	Data+	Green	
4	Data-	Yellow	
5	Ground	Gray	
6	AL	Pink	
7	U/I	Blue	

9.2. Ethernet cable

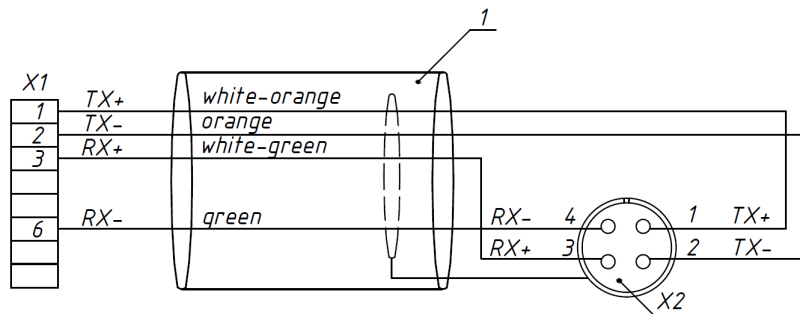
Designations:

X1	RJ-45
X2	Binder 712 99 0409 10 04
1	ETHERNET FD P CAT. 5E 2X2XAWG26/19

Assignment:

Pin number	Assignment	Wire color	Note
1	TX+	White-orange	Transmit data Ethernet +
2	TX-	Orange	Transmit data Ethernet -
3	RX+	White-green	Receive data Ethernet +
4	RX-	Green	Receive data Ethernet -

10. Network setting

All systems are shipped with the following default network configuration: IP address of the system – 192.168.0.3.

Configure your PC's network card in the following address space: 192.168.0.X. Connect system directly to PC or through network switch.

11. Indended use

11.1. Preparation for use

The preparation involves the following steps:

- Visual inspection.
- Installation and connection.
- Switching the system.
- Calibration.

11.1.1. Visual inspection

- Check the system for completeness and absence of damage.
- Check the cables and ground wire.
- Check the condition of output windows and, if necessary, wipe them with a soft cloth.

11.1.2. Installation and connection

- Install the system on a robot or linear translation module (NOTE: as an option, the system can be fixed and the robot sets the object in control position).
- Make electrical connections (see Par. [9](#)).

11.1.3. Switching the system

Feed power to the system – 9...36 V.

11.1.4. Calibration

Calibrate the system according to Par. [12.4.2](#).

The system has to be calibrated only once, there is no need to repeat the calibration process.

11.2. Operating the system

The measurement process is fully automated and operation of the system is reduced to the work with the software.

12. Service software

12.1. General information

The service software is intended for:

- Testing and demonstration of the work of the system.
- Setting parameters.
- Calibration.

The service software includes:

- SDK library.
- RF040 Test Program.

12.2. System requirements

- Operating system Windows 7 and later.
- Microsoft Visual C++ Runtime Redistributable for Windows 64-bit. Shipped with the package (you need to run **vc redistrib_x64.exe**).

12.3. SDK library

SDK contents:

File	Description
rf040.dll	Dynamic-link library.
rf040.h	C header file. Refer to this file to understand the SDK functions. There is the detailed description for each of them.
rf040.lib	LIB file to link DLL to the project.

SDK usage scenario:

Step	Description
1	Call <code>connect()</code> to connect to the system.
2	Call <code>switchSensor(true)</code> to switch on the system.
3	Call <code>calibrate()</code> to run the calibration, or <code>getCalibratedMeasures()</code> to get calibration data.
4	Call <code>getMeasures(result_array)</code> to run the measurement process.
5	Call <code>switchSensor(off)</code> to switch off the system - optional.
6	Call <code>disconnect()</code> to disconnect from the system - optional, called from destructor.

12.4. RF040 Test Program

12.4.1. Connection

When you start the program, it searches for devices connected. If the [network settings](#) of your PC are correct, the program will establish connection with the system.

12.4.2. Calibration

It is necessary to calibrate the system before you start the measurement process. The system has to be calibrated only once, there is no need to repeat the calibration process.

The system is calibrated using the calibration ring, the diameter of which is set programmatically by the "param D0" parameter.

When you see the message *"Place ring #0 and press enter"*, place the calibration ring and press the **Enter** key in order to start the calibration process.

The calibration is performed for 10 positions. So, it's necessary to press the **Enter** key 10 times and to change the position of the calibration ring every time before you press the **Enter** key.

NOTE. The distance from the calibration ring inner surface to the system housing must not be less than 6 mm.

```

x _ Terminal
librf040: Place ring #0 and press enter:
librf040: Press ENTER to measure ring #0 in position #0

librf040: OK: 0.262451 2.27051 4.52576 4.36554 2.15912 0.157166
librf040: Press ENTER to measure ring #0 in position #1

librf040: OK: 1.09253 2.68707 3.94897 3.43628 1.87988 0.726318
librf040: Press ENTER to measure ring #0 in position #2

librf040: Got invalid result (too close to some eye)
librf040: 0 2.41699 4.96063 4.61426 1.96686 0
librf040: Retry? (Y/n):
librf040: OK: 0.382996 2.56958 4.61731 4.14734 1.84631 0.112915
librf040: Press ENTER to measure ring #0 in position #3

librf040: OK: 0.837708 2.72217 4.26178 3.65753 1.80206 0.42572
librf040: Press ENTER to measure ring #0 in position #4

librf040: OK: 1.0849 3.03345 4.3045 3.39355 1.48163 0.387573
librf040: Press ENTER to measure ring #0 in position #5

librf040: OK: 1.02234 2.565 3.96423 3.55072 1.97144 0.674438
librf040: Press ENTER to measure ring #0 in position #6

librf040: OK: 2.15912 3.09448 3.26996 2.40021 1.56097 1.34583
librf040: Press ENTER to measure ring #0 in position #7

librf040: OK: 1.85699 3.74146 4.19464 2.61993 0.857544 0.437927
librf040: Press ENTER to measure ring #0 in position #8

librf040: OK: 1.39008 3.27911 4.22821 3.10669 1.24969 0.430298
librf040: Press ENTER to measure ring #0 in position #9

librf040: OK: 2.04926 3.01208 3.26538 2.48566 1.62659 1.3443
    
```

12.4.3. Measurement

When the system is calibrated, you can start the measurement process.

Press the **Enter** key in order to perform the measurement. The program will show the calculated values:

```

values: 11.015320      12.460327      13.856506      13.667297      12.127686      10.820007
Diameter == 89.901      Radiuses:44.9755      44.9614 44.9159 44.9729 44.9671 44.9101
2D Points:
11.0153 0
-10.9911      33.7192
-57.7618      32.8041
-78.0119      -12.6086
-54.0729      -45.1754
-12.2586      -44.5813

```

9

13. Warranty policy

Warranty assurance for the Multisensor Inner Diameter Measurement System RF040-65/115 Series – 24 months from the date of putting in operation; warranty shelf-life – 12 months.

14. List of changes

Date	Version	Description
15.09.2017	1.0.0	Starting document.