

# MANUAL

HighTECH Line | PROTECTION TECHNOLOGY  
MADE SIMPLE

MRL1 | LOCK-OUT RELAY



**LOCK-OUT RELAY**

Original document

English

Revision: C

**SEG Electronics reserves the right to update any portion of this publication at any time.  
Information provided by SEG Electronics is believed to be correct and reliable.  
However, no responsibility is assumed by SEG Electronics unless otherwise expressly undertaken.**

**© SEG Electronics 1994–2020. All rights reserved.**

## Contents

<b>1. Summary and Applikation</b> .....	<b>4</b>
<b>2. Characteristics and Features</b> .....	<b>5</b>
<b>3. Function</b> .....	<b>6</b>
3.1 Status indicator.....	6
3.2 Resetting .....	6
3.3 <RESET> Push Button .....	7
3.4 Coding Plugs .....	8
<b>4. Testing the relay and commissioning</b> .....	<b>9</b>
4.1 Connecting the auxiliary voltage .....	9
4.2 Testing the tripping circuits .....	9
4.3 Testing the AUTO-RESET function .....	9
4.4 Testing the external RESET input.....	10
<b>5. Terminal block</b> .....	<b>11</b>
<b>6. Technical Data</b> .....	<b>13</b>
6.1 System Data and Test Specifications .....	14
<b>7. Order form</b> .....	<b>15</b>

# 1. Summary and Applikation

---

The MRL1 of the HIGH TECH LINE is generally used as a common lockout relay, e.g. when the number of the available tripping contacts of the protection relay is too low or when the maximum switching capacity of the relay contacts is exceeded while the tripping coil of the circuit breaker is actuated.

## 2. Characteristics and Features

- high switching capacity of the relay contacts
- fulfills the requirements, acc. to BS 142 and IEC 255
- manual, electrical or automatic reset
- low resistive and high resistive design
- tripping time  $\leq 10$  ms

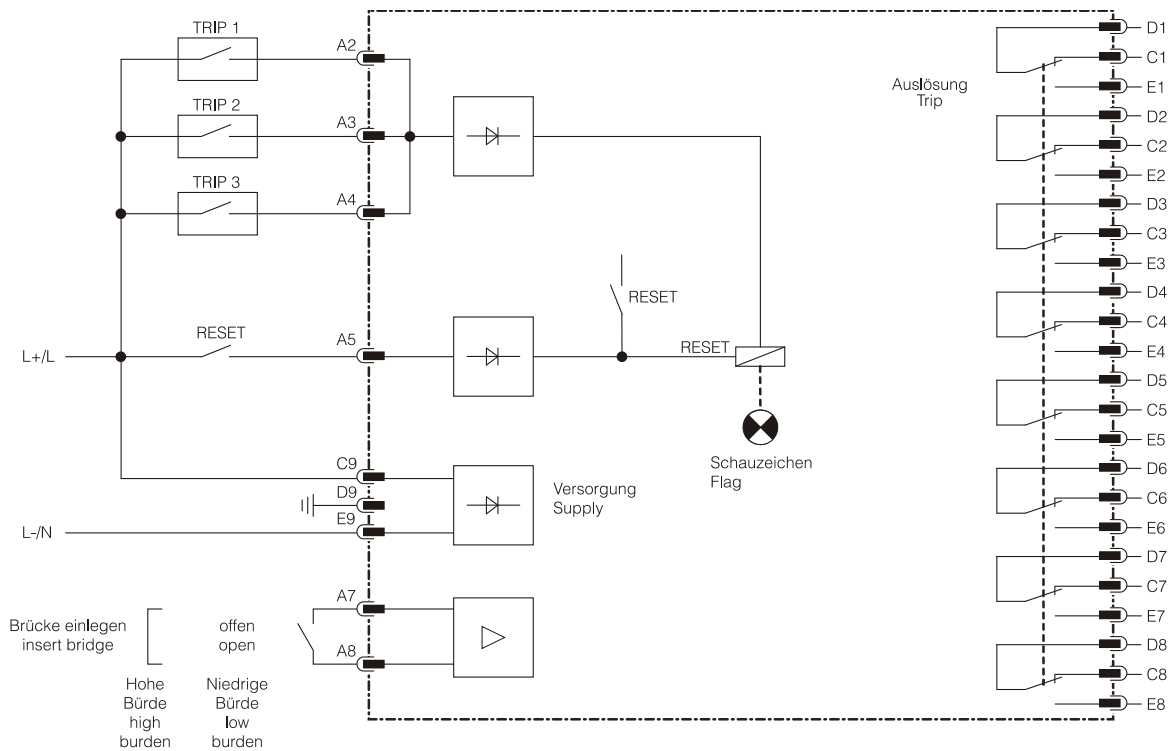

Figure 2.1: Connection diagram MRL1

## 3. Function

The input signals (trip contacts of the protection relays) are led to terminals A2 - A4 of the MRL1. In case of tripping, the output relay switches the 8 change-over contacts over.

The MRL1 can be operated in two different operational modes.

MRL1 with a high burden (mode HB).

Malfunctions can be caused by induced currents at long-distance lines. The MRL1 is provided with a high burden to prevent such malfunctions. By connecting terminals A7 and A8 the burden can be activated. The power consumption of the inputs is then 150W. This high burden is deactivated by the MRL1 at a tripping event. The residual holding power is 3W\* minimum at rated voltage.

MRL1 with a low burden (mode LB).

This operational mode is used where no interference effect on lines is to be expected. Terminals A7 and A8 must not be bridged. The power consumption of the inputs is then 50W. This low burden is deactivated by the MRL1 at a tripping event. The residual holding power is 3W minimum at rated voltage.

About 40 - 60 ms after pick-up of the relay, the input current is interrupted independently of the burden. This delay makes operation of other relays connected in series possible before the trip circuit is disconnected.

\*Depending on the respective rated voltage (see Technical Data).

**Note:**

After a trip action, terminals A2/A3/A4 may only have voltage applied for approx. 10 min.

### 3.1 Status indicator

The status indicator shows whether the MRL1 has tripped. Red means tripping. A dark display means not tripped.

The MRL1 must be reset after every tripping action. There are three possible ways of resetting the protection relay.

### 3.2 Resetting

**RESET key**

The Reset key permits resetting of the output relay and the indicator if the trip signal at terminals A2/A3/A4 has been switched off.

**External RESET**

The output relay and the indicator can be set back by way of the input terminals A5/E9 by applying the supply voltage, after the trip signal at terminals A2/A3/A4 has been switched off.

**Automatic RESET**

Once the trip signals at terminals A2/A3/A4 have been switched off, the output relays and the indicators are set back with delay action. The function is activated by the coding plug located behind the front plate (refer to Chapter 3.4).

### 3.3 <RESET> Push Button

The <RESET> push button is used for acknowledging and resetting the tripping relays after tripping when coding was done accordingly (see para. 3.2).

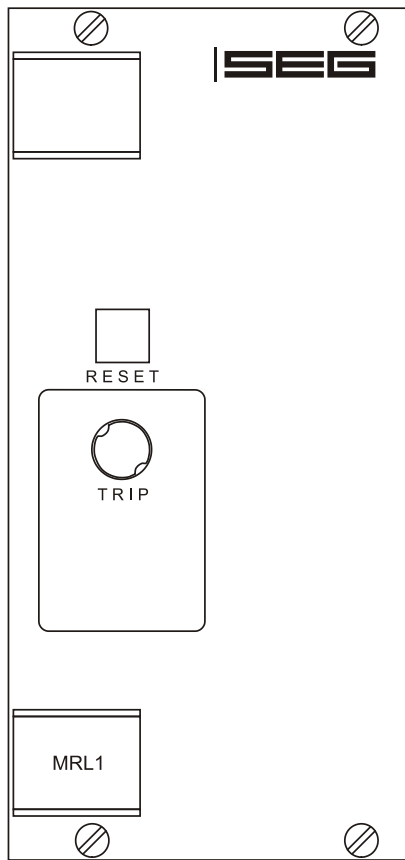

Figure 3.1: Front plate

### 3.4 Coding Plugs

A coding plug for presetting the resetting behavior of the output relay is on the button behind the front plate.

When the coding plugs are plugged in the output relays and the indicator are automatically reset when the tripping command at inputs A2, A3 and A4 is removed.

When the coding plugs are not plugged in the output relays have to be reset manually by actuating the reset push button.

(Factory setting)

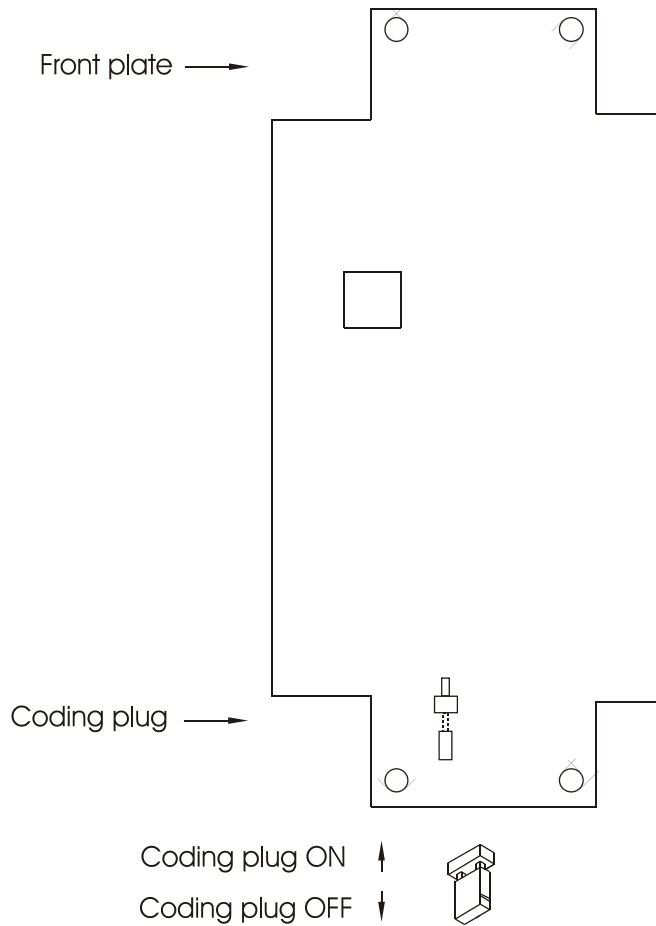

Figure 3.2: Coding plugs



## 4. Testing the relay and commissioning

---

The following testing instructions serve for testing the functions of the device and for commissioning it. In order to prevent destruction of the device and to ensure correct functioning, the following points must be adhered to:

The rated aux. voltage of the device must be the same as the existing local auxiliary voltage. All control and measuring circuits as well as the output relays must be connected correctly.

### 4.1 Connecting the auxiliary voltage

**Please note!**

Before the device is connected to the auxiliary voltage it must be ensured that the aux. voltage is the same as that stated on the type plate of the device.

### 4.2 Testing the tripping circuits

The MRL1 must be connected as shown in the test circuit diagram.  
Remove the coding plug for the automatic reset function. Switch supply voltage on.

Depending on the application, the device can be tested with high or low burden. By actuating switch S1 or S2 or S3, the output relay is energized and the indicator shows red, i.e. tripped. If key S1 or S2 or S3 is re-leased, the MRL1 remains in the tripped position. It is only when the reset key on the front plate is actuated that the output relay is released and the indicator display is dark, i.e. not tripped.

In case of supply voltage failure, the momentary state of the device does not change.

### 4.3 Testing the AUTO-RESET function

If the coding plug Auto-Reset, which is located behind the front plate, is set (refer to Chapter 3.4), the MRL1 automatically returns to the starting position after key S1 or S2 or S3 has been released.

### 4.4 Testing the external RESET input

The coding plug for automatic reset must not be plugged in. Actuate key S1 or S2 or S3. The MRL1 moves back into starting position.

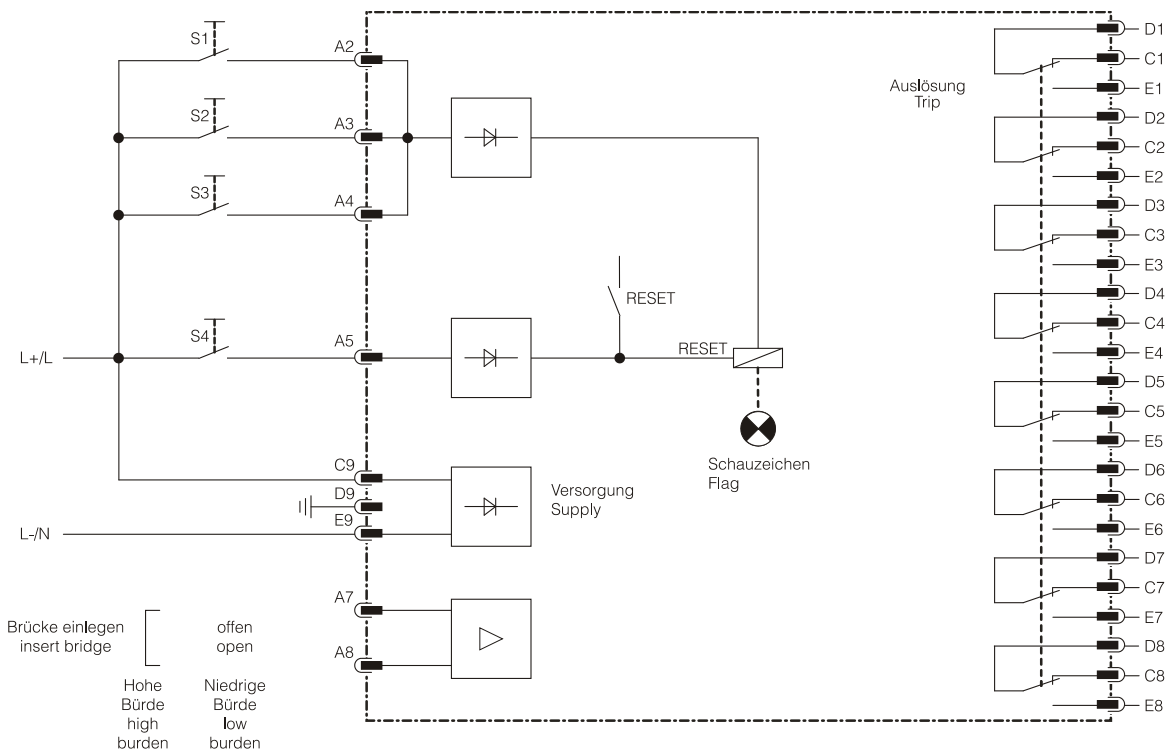

Figure 4.1: Test circuit MRL1

## 5. Terminal block

The plug-in module MRL1 has a very compact base with plug connectors and screw-type connectors:

- 8 screw -type terminals (connection plug row A) for voltage inputs
- 27 poles tab terminals for relay outputs, supply volt-age etc. (terminal connectors series C, D and E, max. 10 A current carrying capacity).

Connection with tabs 6.3 mm x 0.8 mm for cable up to max. 1.5 mm<sup>2</sup> or with tabs 2.8 mm x 0.8 mm for cable up to max. 1 mm<sup>2</sup>.

By using 2.8 x 0.8 mm tabs a bridge connection between different poles is possible.

Screw terminals are provided for easy wiring (daisy chain) of the RS485 interface.

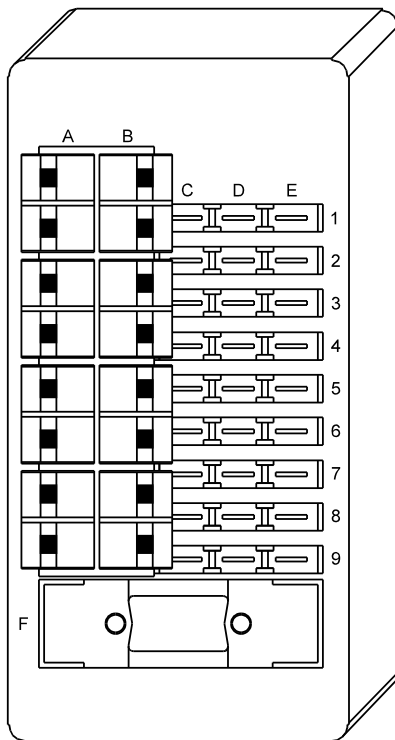

Figure 5.1: Terminal block

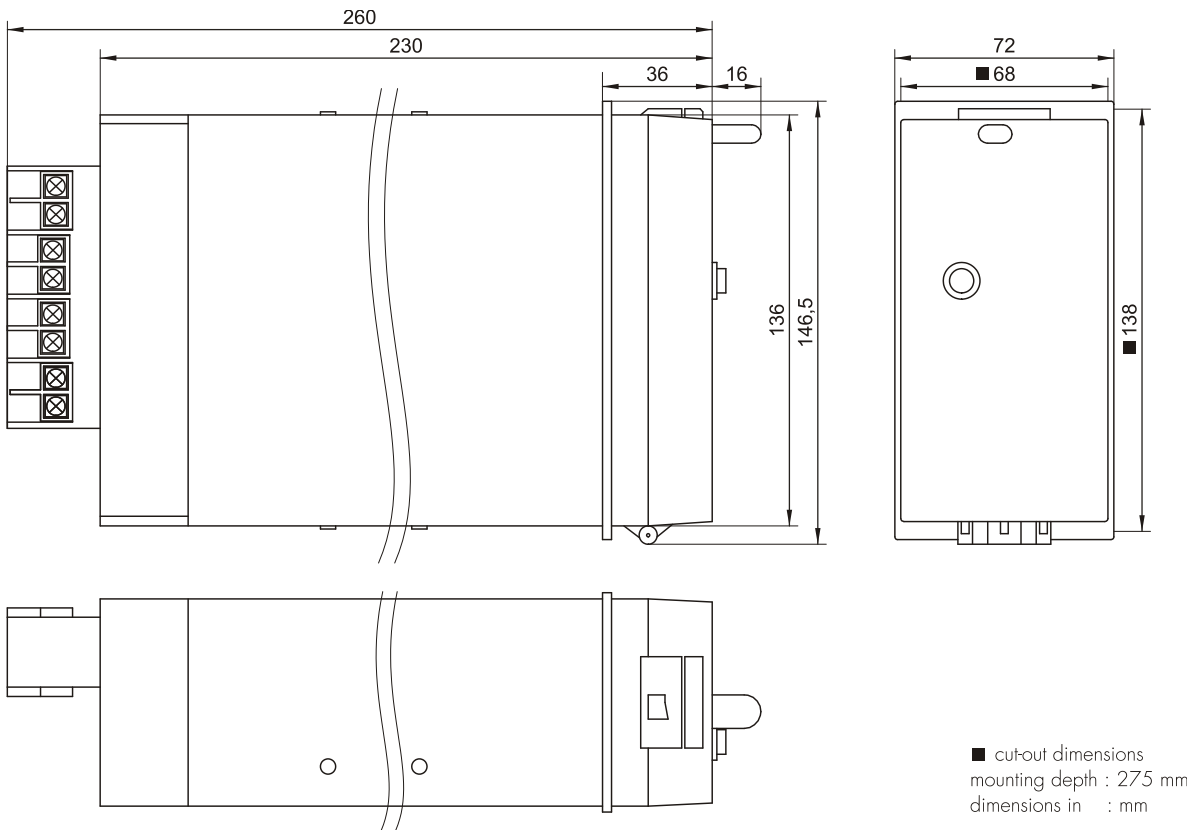

Figure 5.2: Dimensional drawing

**Please observe!**

A distance of 50 mm is necessary when the units are mounted one below the other for the front cover to be easily opened. The front cover can be opened downwards.

## 6. Technical Data

### Supply voltage:

Range	24 V DC	18 – 32 V
	48 V DC	30 – 60 V
	60 V DC	40 – 80 V
	110 V DC	66 V – 150 V
	220 V DC	150 V – 300 V
	Permissible residual ripple:	6 % to IEC 255-6

### Output Relay

Output contacts 8 changeover contacts

Breaking capacity AC: 2650 VA/max. 400 V = 10 A

Breaking capacity DC:

Ohmic:	24 V/5A
	110 V/0.35 A
	300 V/0.20 A
Inductive (L/R < 40 ms):	24 V/1 A
	110 V/0.2 A
	300 V/0.10 A

### Measuring inputs

Response time: 7 - 10 ms

Making capacity

(Terminals A2; A3; A4

Operating mode HB: 150 W

Operating mode LB: 50 W

Minimum operating current\*\*

Operating mode HB*:	24 V $\geq$ 4.7 A
	48 V $\geq$ 2.1 A
	60 V $\geq$ 1.7 A
	110 V $\geq$ 0.83 A
	220 V $\geq$ 0.48 A
	24 V $\geq$ 1.6 A
Operating mode LB*:	48 V $\geq$ 0.68 A
	60 V $\geq$ 0.56 A
	110 V $\geq$ 0.28 A
	220 V $\geq$ 0.16 A

Cyclic duration factor of burden

Min.:  $\geq$  40 ms

Max.:  $\leq$  200 ms

Power consumption  
after switch off burden:

24 V	3.8 W
48 V	3.8 W
60 V	4.4 W
110 V	11.9 W
220 V	16.1 W

Max. cyclic duration factor:  
Terminals A2; A3; A4 10 min.

\* at rated voltage

\*\* at min. acc. supply voltage

## 6.1 System Data and Test Specifications

Design standards:	
Generic standard:	EN 50082-2, EN 50081-1
Product standard:	EN 60255-6, BS142
Specified ambient service temperature limits in operation:	-10°C to +55°C
at storage:	-25°C to +70°C
Moisture-carrying capacity class F as per DIN 40040 and per DIN IEC 68, part 2-3:	rel. humidity <95 % at 40°C for 56 days
Insulation test voltage, inputs and outputs between themselves and to the relay frame as per EN 60255-6, IEC 255-5:	2.5 kV (eff.) / 50 Hz.; 1 min.
Impulse test voltage, inputs and outputs between themselves and to the relay frame as per EN 60255-6, IEC 255-5:	5 kV; 1.2/50 µs, 0.5 J
High frequency interference test voltage, inputs and outputs between themselves and to the relay frame as per EN 60255-6, IEC 255-22-1:	2.5 kV/1 MHz
Electrical discharge (ESD) test as per EN 61000-4-2, IEC 255-22-2:	8 kV air discharge, 6 kV contact discharge
Electrical fast transient (Burst) test as per EN 61000-4-4, IEC 255-22-4: 4 kV / 2.5 kHz, 15 ms	
Radiated electromagnetic field disturbance test as per ENV 50140, IEC 255-22-3:	electric field strength: 10 V/m
Guided radiated electromagnetic field disturbance test as per ENV 50141:	electric field strength: 10 V
Surge immunity test as per EN 61000-4-5:	4 kV
Radio interference suppression test as per EN 55011:	limit value class B
Radio interference radiation test as per EN 55011:	limit value class B

## Mechanical tests:

Shock class 1 acc. to DIN IEC 255-21-2  
 Vibration class 1 acc. to DIN IEC 255-21-1

## Degree of protection (EN60529):

Front panel IP40 by enclosure of the relay case and front plate (relay version D)

Front panel with mounting frame incl. seal  
 ("Harsh Environment Kit for High Tech  
 Line Series", separately available  
 accessory, item number "HTLHEK")

IP54 by enclosure of the relay case and front plate (relay version D)

Rear side terminals

IP 20

Vibration test:

0.5 g, 10 - 300 Hz.

Technical data subject to change without notice !

## 7. Order form

Auslöse- und Hilfsrelais		MRL1-		
Nennspannung (DC)	24 V	Arbeitsbereich 18 – 32 V	<b>24</b>	
	48 V	Arbeitsbereich 30 – 60 V	<b>48</b>	
	110 V	Arbeitsbereich 66 – 150 V	<b>110</b>	
	220 V	Arbeitsbereich 150 – 300 V	<b>220</b>	
Bauform (12TE):	19"- Einschub			<b>A</b>
	Türeinbau			<b>D</b>