

Product info sheet

Humidistat

with Polyga®- humidity measuring element **HG80**
 with one or two changeover contacts **HG80-2**
 with inner rotary knob **HG80i/-2i**
 or set point protection **HG80vs**

Application

The humidistat type HG80 is used as an on-off controller to control the relative air humidity in air ducts of air conditioning units and climatic cabinets, and to control air humidifying and dehumidifying. Other areas of use are storage of foodstuffs and luxury foods, cooling rooms for fruit and vegetables, greenhouses for gardening use, the textile industry, the paper and printing industry, film industry and hospitals.

The humidistat HG80 can be used almost anywhere that air humidity has to be regulated or monitored.

Description of the Humidistat

The humidity measuring element, produced by Galltec under the name Polyga®, consists of several synthetic fabric bands each with 90 individual fibres with a diameter of 3µm. A special process gives the fibre hygroscopic properties. The measuring element absorbs and desorbs humidity. The swelling effect, which is predominantly in a lengthways direction, is carried via a suitable lever system to a microswitch with an extremely small switching path. The measuring element reacts quickly and precisely to the change in air humidity. By adjusting the setpoint value control knob, the lever system is engaged so that when the set air humidity is reached the microswitch is activated.

In the case of the humidistat type HG80-2, a second microswitch is positioned parallel to the first microswitch. After the housing cover has been removed, the second set value can be finely adjusted at the microswitch lever using a screwdriver. The switch point of the second microswitch is connected to the switch point of the first microswitch. The switch distance (neutral zone) can be set from 0% rel. humidity to +15% rel. humidity.

The fan shaped measuring element is protected by a perforated sensor tube and is exposed to the housing. The humidistats are designed for pressureless systems. The mounting position should be chosen such that condensed water cannot get into the interior of the housing. The preferred mounting position is with the „sensor vertically downwards“ or „sensor horizontal“ (see diagram on the reverse). In the mounting positions described above, a blanking plate in the sensor tube with a 0.8mm diameter hole will prevent water getting in.

Notes on voltage

The measurement location of the humidity controller should be selected such that there is no build-up of condensate on or in the device. This applies particularly for operation with a voltage higher than 48V. If the voltage is higher, there is a risk of voltage arcing in the event of water condensation on the microswitch or connecting terminals which might destroy the controller. In the case of voltage below 48V, the humidity controller can be used up to 100%rh.

Technical Data

scale range 30...100%rh
 measuring accuracy
 for measuring range > 50%rh ±3.5%rh
 for measuring range < 50%rh ±4%rh
 range of operation 35...95%rh
 measuring medium air, pressureless, non-aggressive
 switching difference (microswitch) ref. to 50%rh
 approx. 4%rh
 switching distance between the microswitches
 for HG80-2 0...+15%rh
 max. voltage 250 V AC

Please observe the notes on voltage.

breaking capacity of the changeover contact
 ohmic load (cos φ=1) 15A AC 230V
 inductive load (cos φ=0,7) 2A AC 230V
 direct voltage 0.25A DC 230V
 breaking capacity, minimum load 100mA, 125V AC
 contact material silver
 allowable storage temperature -30...+60°C
 allowable operating temperature 0...60°C
 medium temp. coefficient -0.2%/K relative to 20°C and 50%rh
 adjustment at average air pressure 430 m NN
 allowable air speed 8m/sec
 with gauze protection (order no. 20.014) 15m/sec
 with PTFE filter (order no. 23.063) 15 m/sec
 time constant T₆₃ at v=2m/sec 120 sec
 sensor length, material 220mm, high-grade steel
 fixing slots in the housing base for duct mounting
 (ord. no. 20.009) console for wall mounting
 mounting position sensor vertically downwards or horizontally
 connecting terminals for conductor cross sections 1.5mm²
 cable connection via twist nipple M20x1.5

applied directives / standards

low-voltage directive 2014/35/EU
 EMC directive 2014/30/EU
 DIN EN 60730-1:2012-10
 DIN EN 60730-2-13:2008-09

housing ABS light grey
 type of protection (external rotary knob) IP 54
 type of protection (inner rotary knob HG80i, HG802i) IP64
 measuring element
 Polyga®-measuring element, water resistant, washable
 weight approx. 0.7 kg

Dimensions diagram

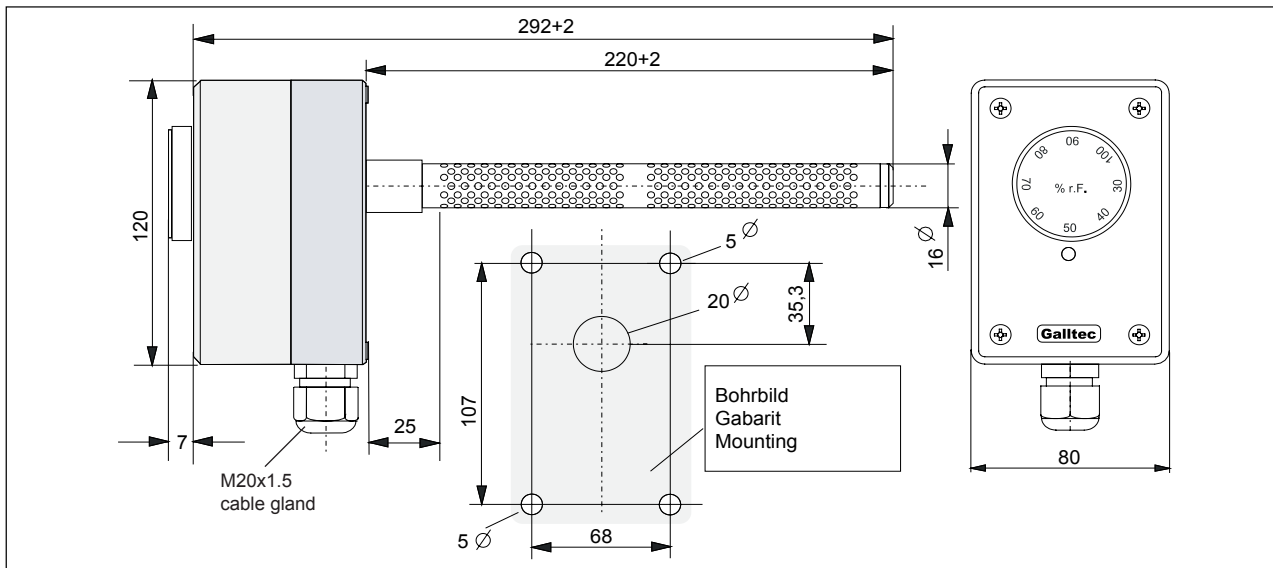

Connection diagram

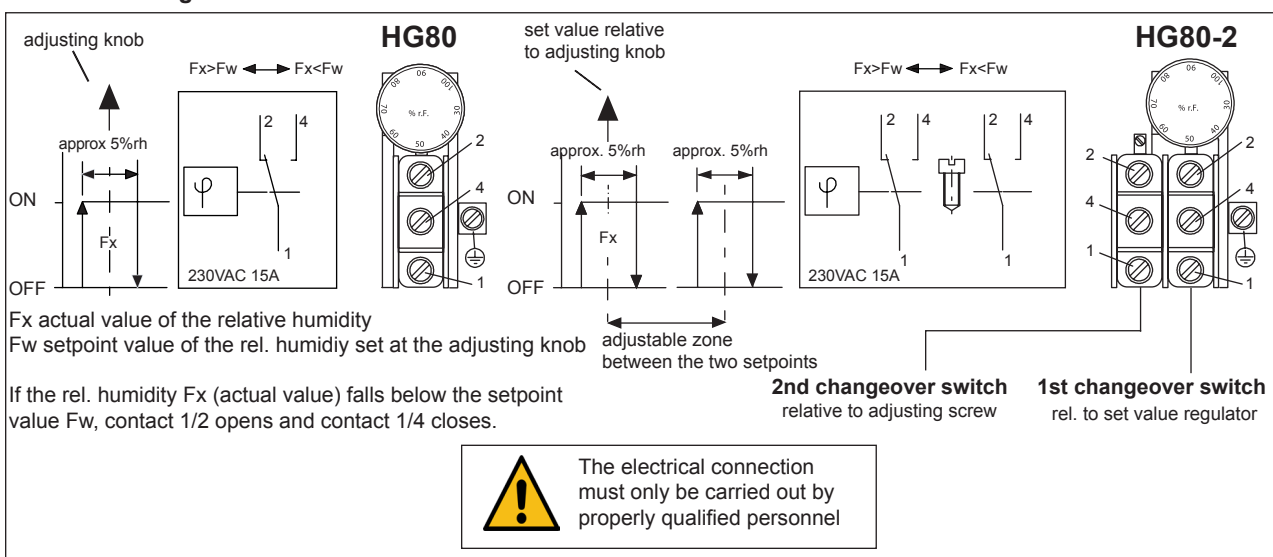

Adjusting the 2nd setpoint value

The humidistats HG80-2(i) are set by the factory such that the 2nd setpoint value is 6% rel. humidity higher than the 1st setpoint value.

The neutral zone (distance between the 1st and 2nd setpoint value) can be adjusted after removing the housing cover using a screwdriver. If turned to the left, the 2nd setpoint value goes up (from +0%rh to +15%rh relative to the 1st setpoint value).

The neutral zone can be read using the rotary knob.

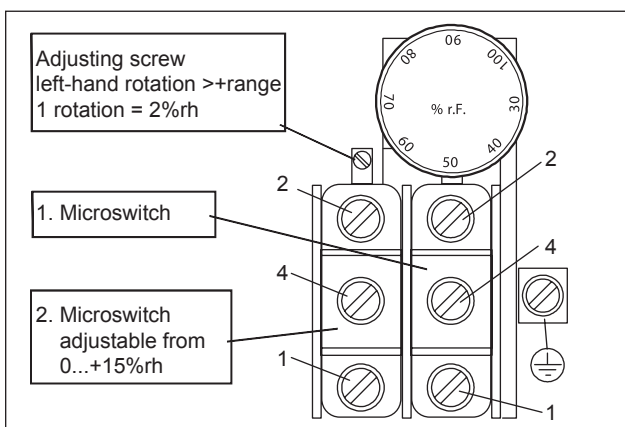

Accessories - Dimensions

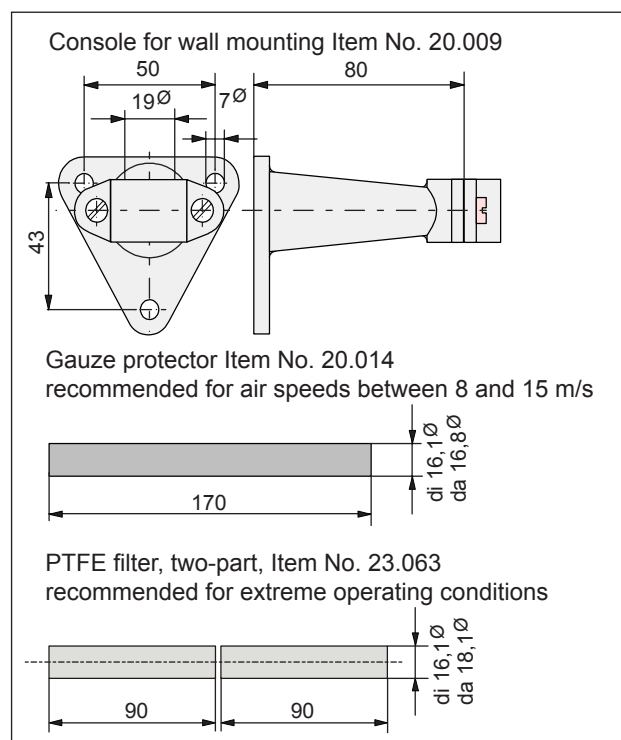

Operating instructions for channel humidistat HG80 and HG80-2

Mounting

- The humidistats must not come into direct contact with water (e.g. splashed water when cleaning the climatic chamber etc.)
- The mounting location should be chosen so that a representative measurement of the air humidity can be guaranteed, i.e. the humidity readings at the mounting location should correspond to those in the room as far as possible.
- The humidistat should be exposed to the flow of air.

Operating information:

Note that, with restrictions in the upper range of operation, the possible tolerances (measurement accuracy, switching difference and temperature coefficient) should be observed when adjusting the switch point.

Preferred mounting positions

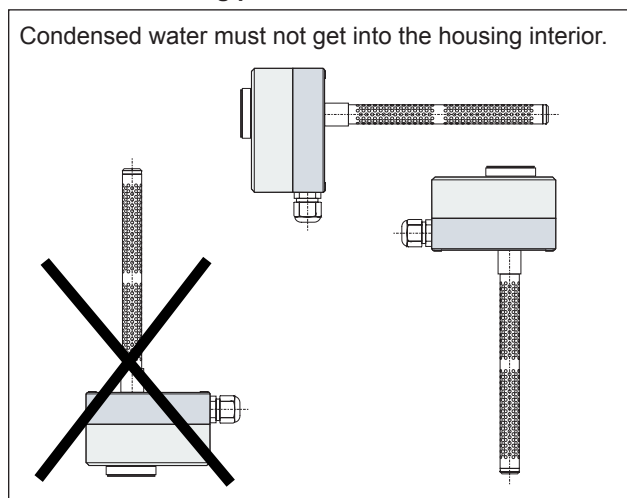

Exterior mounting

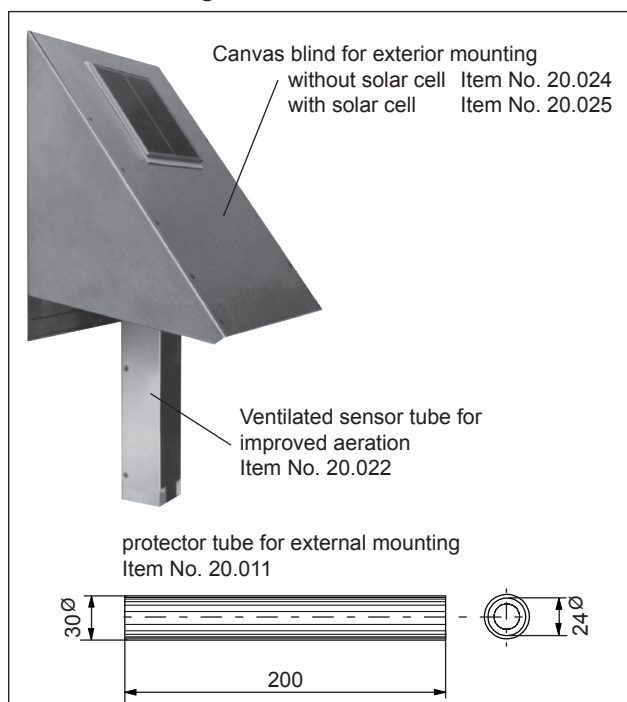

NOTE

Contact with the inner parts of the humidistat nullifies the warranty.

Calibration

Equipment with Galltec humidistats is correctly set by the factory at a room temperature of 23°C and 50% rel. humidity, relative to the average air pressure of 430m NN.

If, however, subsequent adjustment should be necessary, the following procedure should be observed.

- Ensure that the ambient humidity and the ambient temperature are constant.
- If possible, use a psychrometer for checking (no checking equipment with capacitive sensors).
- Leave the equipment to be checked for at least 1 hour in a constant checking climate.
- The adjuster screw is at the end of the sensor - fixed with screw securing lacquer. After removing the lacquer, the adjuster screw can be moved. A right-hand rotation means that the measured value goes down, and with a left-hand rotation the measured value goes up. After calibration, the adjuster screw should again be secured.

Important. The water absorption capacity of the air is influenced, amongst other things, by the temperature. This is a physical law (which can be seen from the hx diagram of Mollier). The higher the air temperature, the greater the volume of water vapour that can be absorbed up to saturation point (100%rh). If a hygrometer is now calibrated at fluctuating air temperature, there is an irregular, non-homogeneous measured medium and there are automatically calibration errors. The table below shows the influence of the air temperature on air humidity. If, for example, calibration occurs at an air temperature of 20 °C and 50%rh, and at a temperature fluctuation of just ±1 °K, then there will be a humidity fluctuation in the measured medium (air) of ±3.2%rh.

	10°C	20°C	30°C	50°C
10%rh	+/-0,7%rh	+/-0,6%rh	+/-0,6%rh	+/-0,5%rh
50%rh	+/-3,5%rh	+/-3,2%rh	+/-3,0%rh	+/-2,6%rh
90%rh	+/-6,3%rh	+/-5,7%rh	+/-5,4%rh	+/-4,6%rh

Accessories

Order no.	Description
20.009	wall console of plastic, for mounting sensors Ø 20 mm with mounting sleeve 00.502 also suitable for sensor tubes Ø 15 mm
20.008	fixing flange for duct mounting of HG80 and FG80 <i>optional attachment for a quicker removal of the sensor</i>
23.063	PTFE filter, two-part, <i>recommended for extreme operating conditions</i>
20.014	protective tube made of gauze <i>recommended for air speeds between 8 and 15 m/s</i>

Maintenance instructions

for humidity measuring equipment with Polyga®humidity measuring element.

Impact of dirt

The measuring element is maintenance-free in pure ambient air. Depending on their type and concentration, aggressive media containing solvents can cause incorrect readings or cause the humidistat to fail. Substances deposited on the measuring element (e. g. resin aerosols, paint aerosols, smoke deposits etc.) are harmful as they eventually form a water-repellent film. The water-resistant property of the Galltec measuring elements allows cleaning to be carried out in water. Solvents cannot be used for this purpose. A light-duty detergent is recommended, but any residue should always be washed out thoroughly.

A special process ensures that Galltec sensors have good long-term stability. Regeneration is not necessary, but is also not harmful. The water-repellent property of the Galltec® humidity measuring element allows cleaning to be carried out in water. An important benefit when the sensors are used in extreme atmospheres.

Cleaning instruction

for humidity sensors, humidistats in channel design as well as all shaft equipment, FG80..., TFG80..., HG80, HG80-2.

The humidity measuring equipment is designed with a perforated sensor tube. The humidity and temperature measuring elements are in the interior of the sensor tube. The humidity measuring element is arranged axially and the temperature measuring element is seated sideways at the top or bottom between the perforation holes.

Measuring equipment with Pt100 glass measuring resistors can be immersed in water. Other temperature sensors, in particular semi-conductor sensors or customer-specific temperature sensors should not come into contact with water. Enquire if in doubt.

The measuring elements are designed for use in pressureless air (gases). The measurement accuracy depends on the degree of pollution of the element. The humidity measuring element, in particular, loses its hygroscopic properties if the surface is covered with grease, soot, smoke deposits, paint, resinous substances etc. By cleaning the elements, their function can be reproduced, but only if no damage is caused by acids, alkaline solutions or other aggressive substances.

Cleaning process

1. Disconnect the device from the power supply!

2. Dip the sensor tube into a receptacle containing clean water (20°C) and, with a gentle rotating motion, disperse the dirt deposits. If the dirt contains grease deposits, it is recommended that a mild detergent be added to the water.

Do not brush or treat with any other cleaning utensils. Only the sensor tube should be immersed - not the housing.

The sensor tube is open to the housing interior (0.8mm hole)

3. As mild detergents are known to contain chemical substances, rinse carefully after cleaning. Cleaning residue will impair the measured result.

4. Air drying. Where a measuring element is moistened with water, the device indicates 100% relative humidity. If necessary, it is possible to carry out sensitive recalibration at the adjusting spindle at the end of the sensor. This should only be done where there are large deviations. Slight movement of the adjusting spindle of a wet element causes the measured value in the dry area to be badly out. Here, there is an intensifying effect of the linearisation (factor 6). Indications of 98..100% relative humidity at the wet element are adequate.

The accuracy in the dry area must be determined under normal climatic conditions.

The measuring element must not be dried using warm or hot air (hair dryer).

Cleaning should be carried out for no longer than some seconds.

Installation advises

On installation ensure that there is sufficient overcurrent protection (e. g. fuse). Also a separation device (e. g. plug or switch) has to be installed.

Further details informationen you will find in „HUMIDITY SENSOR IN ACCORDANCE WITH THE ABSORPTION PRINCIPLE“