



DYNAMIC LINE

SERVO MOTORS

EN



CONTENTS

PAGE

System description	4
Dynamic Line DL3	6
Planetary gears, Motor- and Encoder cables	8
Dynamic Line DL2	11
Geared servo motors TA	14
Adresses	15

SYSTEM OVERVIEW

Automation with Drive

Drive is movement, dynamics, precision, endurance, continuity and much more.

Whether managing formulations, an optimized operator interface or the controlled movement of axes – it all requires a clear overview combined with logic and is based essentially on the selection of the right technology.

The integrated KEB system offers the best basis for high performance and economics in the application as well as excellent efficiency in the practical implementation.

KEB provides the right solutions!

SOFTWARE



HMI



CONTROL

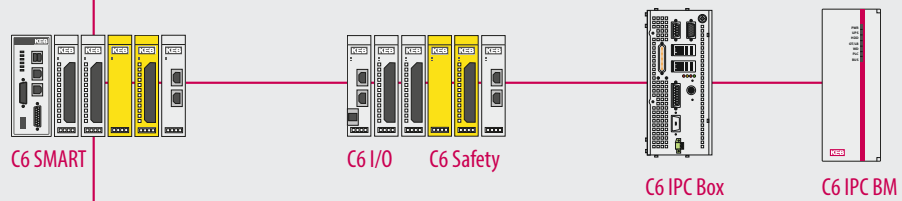

DRIVES

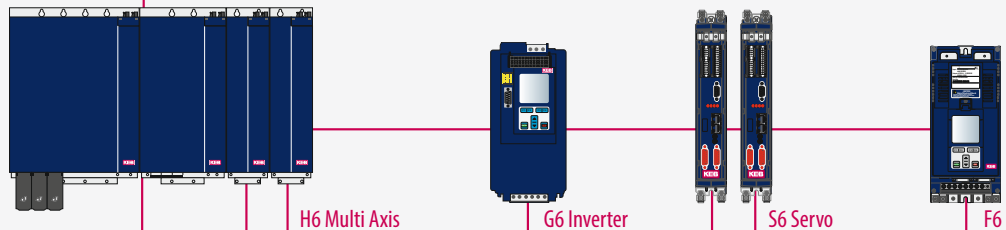

MOTORS

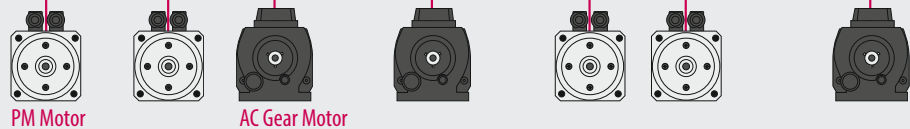

SERVO MOTORS IN THE COMPLETE SYSTEM

OPTIMALLY COORDINATED FEATURES – THE KEY TO SUCCESS

From the user interface to the rotating movement – it is our goal to make sure: we provide all the tasks you require from a single supplier. KEB drive controllers have proven themselves in the market for many years. Now we have expanded our range to provide an all-in-one package. The core control function is provided with IPC based control technology, along with software tools, a flexible range for visualisation, and remote maintenance.

Optimum rotating movement is provided by the servo motors, which are available in three series, each with specific benefits. With energy efficiency ratings significantly above IE4 (three-phase asynchronous motors) there is a strong argument in favour of synchronous drive systems. Real time process control is also possible in combination with the COMBIVERT Drive Controller.

The package is complimented with pre-fabricated motor and encoder cables. This allows easy installation, fast start-up and safe operation. Select the right motor for your optimum drive solution from a portfolio that is tailored to meet your specific requirements.



DYNAMIC LINE DL 3 *economical, durable, powerful*



DYNAMIC LINE DL 2 *for special requirements*

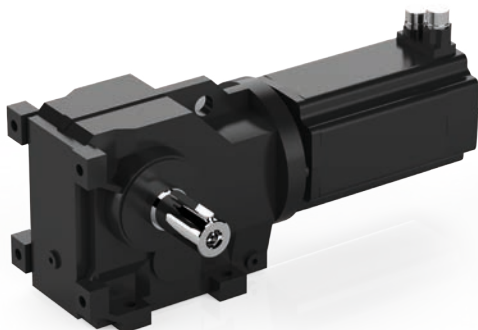

TA SERIES *optimized for the geared motor solution*

O_SMH	0.2 - 0.5
A_SMH	0.5 - 1.2
B_SMH	1.38 - 3.22
C_SMH	2.45 - 5.65
D_SMH	4.9 - 11.4
E_SMH	12.8 - 29.0
F_SMH	31,8 - 72,6

Stall torque in Nm

DYNAMIC LINE DL 3

With seven physical design sizes and three alternative lengths, this new series covers application areas from the infeed axis to the main drive. A high degree of density gives excellent peak torques in compact dimensions, whilst built-in modularity offers a flexible solution for the widest verity of tasks.

The broad speed range provides the basis for minimal variation and universal use. Dynamic Line DL 3 series motors create an excellent base for high-performance machines and systems, capable of handling dynamic applications and high loads



GENERAL SPEED-TORQUE CHARACTERISTIC

DEFINITION

T_{do}	Stall torque ($n=0$)
T_{max}	max. torque
T_{dN}	Rated torque
n_N	Rated speed
n_{max}	max. speed
U_{DC}	DC link voltage

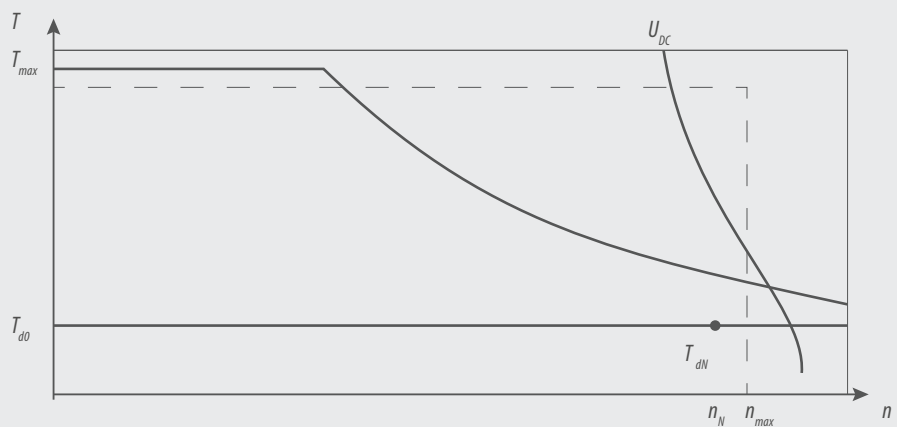

DYNAMIC LINE DL 3

MOTOR	U _n [V]	T _{dN} [Nm]	T _{d0} [Nm]	T _{max} [Nm]	n _N [rpm]	J _L [kgcm ²]	A [mm]	B □ [mm]	C (without brake) [mm]	C (with brake) [mm]	D _{k6} ∅ [mm]	L [mm]	N _{j6} ∅ [mm]	P ∅ [mm]	T _{Brake} [Nm]
01SMH		0.18	0.2	0.68		0.029			97	129					
02SMH	230	0.33	0.38	1.37	8,000	0.048	65.4	40	117	149	8	22,5	30	46	0.6
03SMH		0.45	0.52	2.04		0.067			137	169					
A1SMH		0.5	0.5	2.69		0.134			111.5	146					
A2SMH		0.7	0.8	4.18	8,000	0.253	82.5	58	133.5	168	9	20	40	63	2.0
A3SMH		1.0	1.2	6.36		0.373			155.5	190					
B1SMH		1.33	1.38	6.07		0.462			129	168					2.0
B2SMH		2.2	2.37	11.6	6,000	0.842	96.5	72	154	194	14	30	60	75	3.5
B3SMH		2.7	3.22	17.71		1.22			180	229					
C1SMH		2.31	2.45	9.14	6,000	1.08			132	179.5					
C2SMH		3.7	4.1	18.9	5,000	1.98	128.5	87	162	209.5	19	40	80	100	9.0
C3SMH	400	4.9	5.65	29.25	5,000	2.87			192	239.5					
D1SMH		4.4	4.9	17.76	5,000	2.23			136.5	183.5					9.0
D2SMH		6.9	8.2	35.34	4,000	4.06	145.5	104	169.5	216.5	24	50	95	115	13.0
D3SMH		8.35	11.4	53.13	4,000	5.88			202.5	251.5					
E1SMH		11.0	12.8	37.08		13.4			176	228					20.0
E2SMH		15.2	21.1	74.16	3,000	22.3	183.5	142	216	268	32	58	130	165	30.0
E3SMH		13.2	29.0	110.8		34.9			256	315					
F1SMH		19.5	31.8	79.81	3,000	49.6			212	284.5					
F2SMH		38.2	54.8	172.5	2,000	92.3	256	194	269	341.5	38	80	180	215	70.0
F3SMH		38.8	72.6	275.3	2,000	134.9			326	398.5					

Features:

right angle plug, shaft without keyway,
KTY-Sensor, protection IP 54

Options:

permanent magnet brake,
shaft with keyway

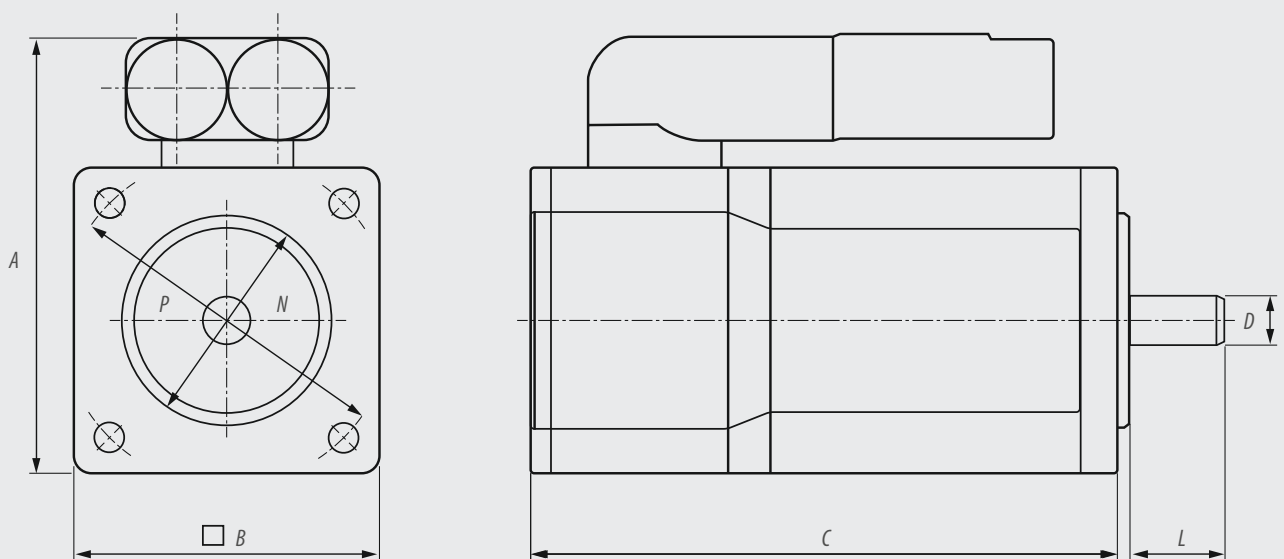

ENCODER SYSTEMS

Resolver resolution 12 bit/revolution (SAFETY READY)
 Hiperface Singleturn - 17 bit/revolution Multiturn - 12 bit/revolution – 17 bit revolution

Prepared for the operation with: **COMBIVERT S6 COMBIVERT F6 COMBIVERT H6**

GEAR SIZE	T_{2N} [Nm]	T_{2max} [Nm]	n_{max} [rpm]	i	backlash arc _{min}	C Ø [mm]	D_{k6} Ø [mm]	N_{j6} Ø [mm]	P Ø [mm]	DL3-Motors
1	5 ... 15	8 ... 24	5,000	5 ... 40	15	50	12	35	44	A
2	15 ... 33	24 ... 53	4,500		10	70	16	52	62	A B C
3	38 ... 90	61 ... 144	4,000		7	90	22	68	80	B C D E
4	95 ... 195	152 ... 312	3,000		7	120	32	90	108	C D E
5	210 ... 460	336 ... 736	2,800		8	155	40	120	140	D E

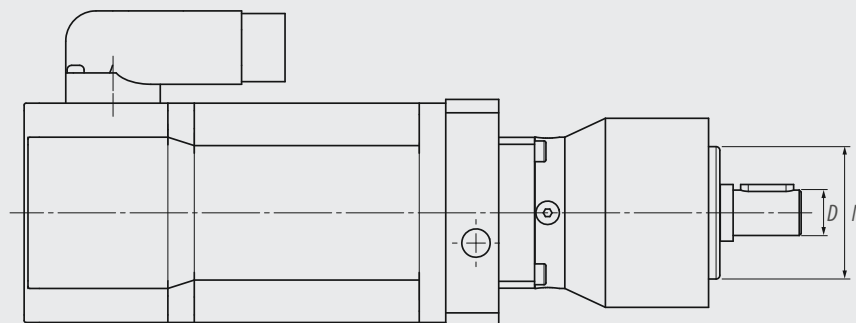
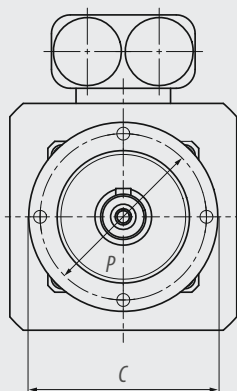

PLANETARY GEARS SGPP BUNDLED WITH DYNAMIC LINE 3:

- Low backlash
- High torque
- High efficiency (97%)
- Ratio $i=5$ up to 40
- Low noise
- Lifetime lubrication



INDUSTRY SEGMENTS

- Machine tools
- Metal forming
- Packaging technology
- Food technology
- Wood working systems
- General automation devices

APPLICATION EXAMPLES

- Revolving tables
- Tool changer
- Roboter and handling devices
- Linear positioning
- Conveyor drives
- Winder

ENCODER CABLES

MOTOR DL3	ENCODER	DRIVE CONTROLLER	PART-NO	AVAILABLE LENGTH [m]
A ... F SMH	Resolver	S6 / F6	00S6L50-0xxx	1 ... 30 / 35 ... 50
		H6	00H6L50-0xxx	2.5 / 5 / 7.5 / 10 / 15 ... 50
	Hiperface SKS / SKM	S6 / F6	00S6L55-0xxx	1 ... 30 / 35 ... 50
		H6	00H6L55-0xxx	2.5 / 5 / 7.5 / 10 / 15 ... 50
MOTOR DL2 / TA	ENCODER	DRIVE CONTROLLER	PART-NO	AVAILABLE LENGTH [m]
__ SM5 __ SMT	Resolver	S6 / F6	00S6L50-1xxx	1 ... 30 / 35 ... 50
		H6	00H6L50-1xxx	2.5 / 5 / 7.5 / 10 / 15 ... 50
		F5	00F50C1-1xxx	2.5 / 5 / 7.5 / 10 / 15 ... 30
	BISS	S6 / F6	00S6L51-2xxx	1 ... 30 / 35 ... 50
		H6	00H6L51-2xxx	2.5 / 5 / 7.5 / 10 / 15 ... 50
		F5	00F50C1-Vxxx	2.5 / 5 / 7.5 / 10 / 15 ... 30
Hiperface SKS / SKM	S6 / F6	00S6L55-1xxx	1 ... 30 / 35 ... 50	
	H6	00H6L55-1xxx	2.5 / 5 / 7.5 / 10 / 15 ... 50	

MOTOR CABLES

MOTOR DL3	DRIVE CONTROLLER	PART-NO	AVAILABLE LENGTH [m]
0, A, B SMH	S6 / F6	00H6L10-0xxx	1 ... 30 / 35 ... 50
C ... F SMH		H6	
MOTOR DL2 / TA			
A ... F SM5	F5		
A ... F SMT			
TA 1 ... 5			

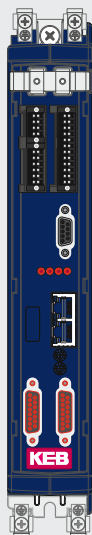

S6

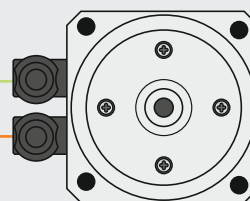

PM MOTOR

FOR THE SPECIAL REQUIREMENTS

A_SM5	0.47 – 1.14	
B_SM5	0.92 – 2.6	
C_SM5	3.9 – 8.5	
D_SM5	8.2 – 18.4	
E_SM5	23.5 – 48.0	Stall torque in Nm



DYNAMIC LINE DL 2

This series offers the latest motor technology in five physical design sizes. They have been configured for tasks with a high system resolution, short designs and small build volumes, and are particularly suitable for difficult mechanical conditions such as vibration, installation, location or temperature.

With pre-fabricated cables and an electronic name plate (BISS) the start-up process and potential for error during installation is minimized. The result is a high degree of availability and maximum serviceability.

GENERAL SPEED-TORQUE CHARACTERISTIC

DEFINITION

T_{d0}	Stall torque ($n=0$)
T_{max}	max. torque
T_{dN}	Rated torque
n_N	Rated speed
n_{max}	max. speed
U_{DC}	DC link voltage

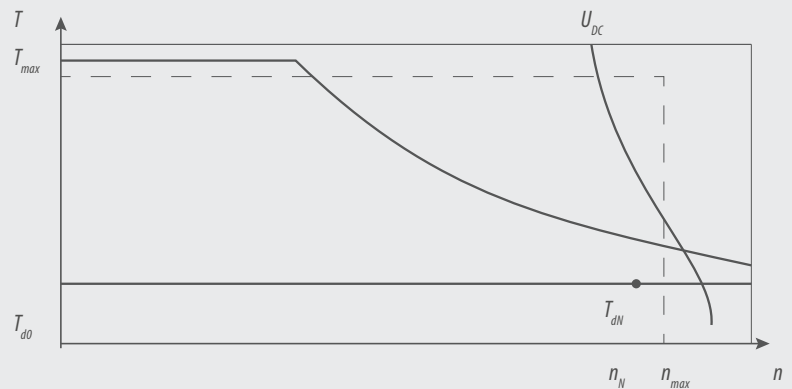

MOTOR	T_{dN}	T_{d0}	T_{MAX}	N_N	J_L	A	B	C (without brake)		additive	L	D_{K6}	N_{J6}	P	T_{BRAKE}
	[Nm]	[Nm]	[Nm]	[rpm]	[kgcm ²]	[mm]	□ [mm]	resolver	BISS	Brake	[mm]	∅ [mm]	∅ [mm]	∅ [mm]	[Nm]
A1SM5	0.43	0.47	2.1		0.13			121	156	25					
A2SM5	0.62	0.66	2.9		0.18			133	168	25					
A3SM5	0.8	0.87	3.8	6,000	0.23	99	55	145	180	25	20	9	40	63	2.0
A4SM5	1.05	1.14	5.0		0.34			170	205	25					
B1SM5	0.9 / 0.87 / 0.76	0.92	2.7	3,000 /	0.30			132	174	42					
B2SM5	1.83 / 1.75 / 1.5	1.8	5.4	4,000 /	0.56	117	75	158	200	42	30	14	80	100	4.5
B3SM5	2.6 / 2.5 / 2.3	2.6	7.8	6,000	0.79			184	226	42					
C1SM5	3.8 / 3.5 / 3.1	3.9	12		2.7			178	220	42					
C2SM5	5.5 / 4.8 / 4.2	5.7	17.5	2,000 /	3.7			206	248	42	40	19	95	115	10
C3SM5	6.9 / 6.4 / 5.7	7.1	22	3,000 /	4.7	137	102	234	276	42					
C4SM5	8.3 / 7.6 / 6.8	8.5	26	4,000	6.0			262	304	42					
D1SM5	8.0 / 7.6 / 6.8	8.2	25		7.9			203	245	42					
D2SM5	11.5 / 11.0 / 9.5	11.6	36	1,500 /	11.2			233	275	42	50	24	130	165	22
D3SM5	15.0 / 14.0 / 11.9	15.3	47	2,000 /	14.4	169	140	263	305	42					
D4SM5	18.0 / 16.9 / 13.7	18.4	57	3,000	19.5			293	335	42					
E1SM5	23 / 19 / 14	23.5	37.08	1,000 /	57			266	293	34					
E2SM5	34 / 28 / 19	35.0	74.16	2,000 /	79	256.5	195	294	321	34	58	32	180	215	60
E3SM5	47 / 40 / 27	48.0	110.8	3,000	102			322	349	34					

ENCODER SYSTEMS

Resolver resolution 12 bit/revolution

BISS Singleturn - 19 bit/revolution Multiturn -12 bit/revolution – 19 bit revolution

Features:

right angle plug, shaft without keyway,
PTC-Sensor, protection IP 54

Options:

permanent magnet brake, shaft with keyway,
protection IP65 - shaft exit, with forced cooling

Prepared for the operation with:

COMBIVERT F5 COMBIVERT S6 COMBIVERT F6 COMBIVERT H6

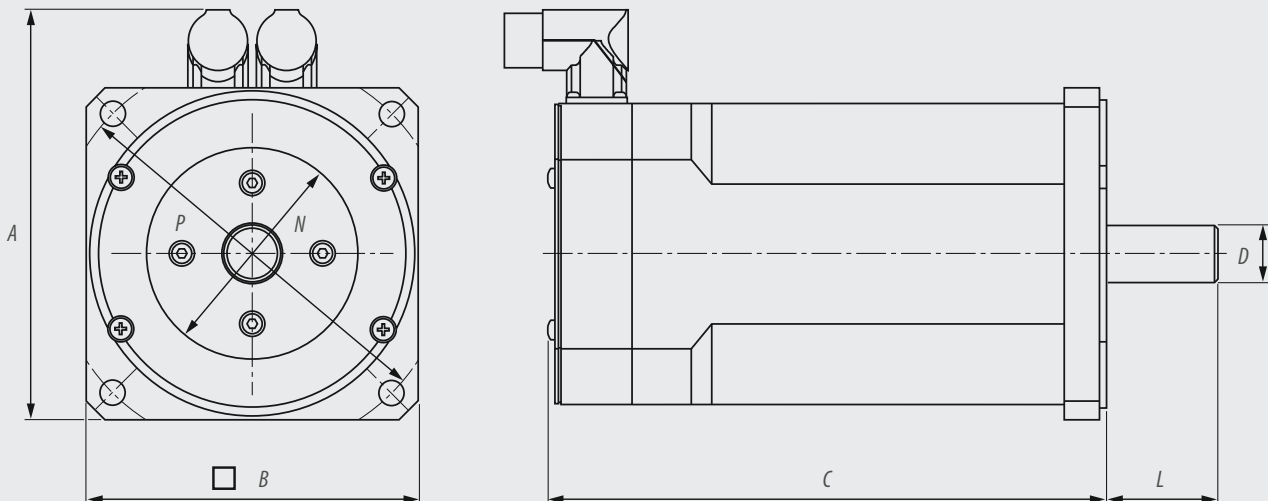

OPTIMISED FOR MODULAR GEARBOX

HELICAL GEAR G

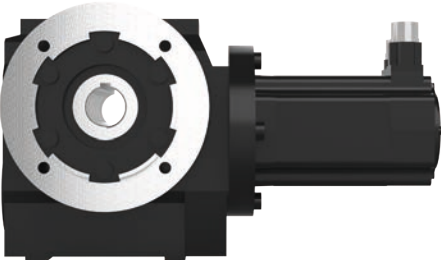

HELICAL WORM GEAR S

PLANETARY GEAR (P)



HELICAL BEVEL GEAR K

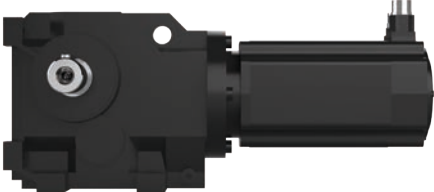

SHAFT MOUNTED HELICAL GEAR F

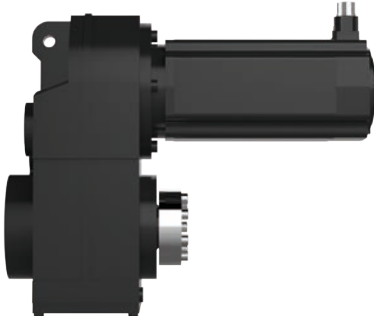

TA 1_ **0.5 - 0.9**

TA 2_ **1.3 - 3.1**

TA 3_ **2.9 - 6.4**

TA 4_ **6.9 - 11.7**

TA 5_ **11.5 - 30.0**

TA 6_ **34.5 - 90.0**

Stall torque in Nm

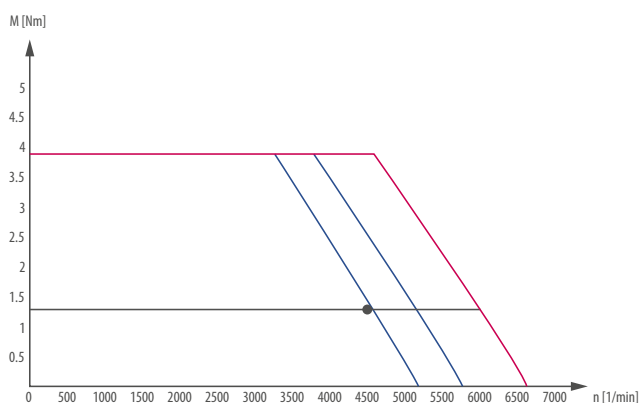
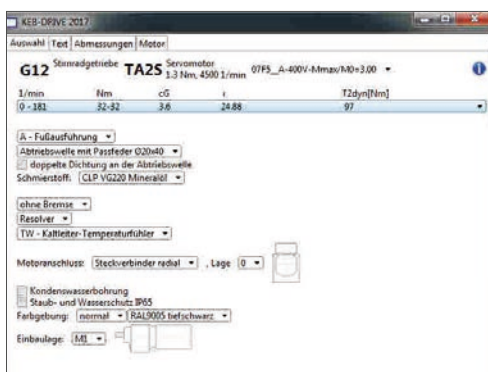

TA SERIES

Servo technology in combination with an industrial gear box module gives rise to a variety of servo geared motor types:

Spur, shaft-mounted helical, helical worm, helical bevel and planetary gear.

The direct input into the gearhead reduces the work that would otherwise be required with a conventional connection coupler, increasing efficiency and service life in a particularly compact design.

As a flexible solution from the gearhead module, the servo gear motor offers high overall efficiency and excellent dynamics, as well as reduced backlash option (on request). The series TA offers properties such as lifetime lubrication, universal installation positions and robust mechanics.

KEB DRIVE

is our perfect software tool for geared motor selections, based on a combination of continuous torque and peak current dependent on the nominal torque. It also provides technical data sheets, 2D and 3D engineering files as well as the ability to allocate a matching controller.

TYPE TA

MOTOR	T_N [Nm]	T_0 [Nm]	T_{MAX} [Nm]	N_N [rpm]	J_L [kgcm ²]	A [mm]	B □ [mm]	C [mm]				D_{K6} ∅[mm]	L [mm]	N_{J6} ∅[mm]	P ∅[mm]	GEAR (available)				
								resolver	brake + resolver	absolute encoder	brake + absolute encoder					G	F	S	K	P
TA 1S	0.49 / 0.48	0.5	1.5	4,500 /	0.136	104.5	58	134	169	161	196	9	20	40	63	■	-	■	■	■
TA 1M	0.89 / 0.88	0.9	2.7	6,000	0.2			164	199	191	226									
TA 2S	1.29 / 1.28	1.3	3.9	4,500 / 6,000	0.391	117.5	75	153	178	180	205	11	23	60	75	■	-	■	■	■
TA 2M	2.2 / 2	2.4	7.2		0.66			193	218	220	245									
TA 2L	2.8	3.1	9.3		0.927			233	258	260	285									
TA 3S	2.6 / 2.45 / 2.25	2.9	8.7	3,000 /	1.13	132.5	90	166	216	193	243	14	30	80	100	■	■	■	■	■
TA 3M	4.2 / 3.8 / 3.4	4.8	14.4	4,500 /	1.95			216	266	243	293									
TA 3L	5.3 / 4.2 / 3.9	6.4	19.2	6,000	2.76	266	316	293	343											
TA 41	6.6 / 6.3 / 5.7	6.9	20.7	2,000 /	5.65	160	116	241	276	261	296	19	40	110	130	■	■	■	■	■
TA 42	8.6 / 8.1 / 7.1	9.2	27.6	3,000 /	8.15			276	311	296	331									
TA 43	10.8 / 10.1 / 8.6	11.7	35.1	4,500	10.65	311	346	331	366											
TA 51	10.8 / 10.2 / 9	11.5	34.5	2,000 / 3,000 / 4,500	14.9	188	145	273	308	293	328	24	50	130	165	■	■	■	■	-
TA 52	14.7 / 13.5 / 11.3	16.1	48.3		21.53			188	308	343	328					363				
TA 53	17.7 / 16.1 / 10.4	20	60		28.15			188	343	378	363					398				
TA 53F	27 / 24 / 15.5	30	60		28.15			194.5	473	528	473					528				
TA 61	31.5 / 30 / 26	34.5	103.5	1,500 / 2,000 / 3,000	77.71	188	188	367	407	387	427	32	58	180	215	■	■	■	■	-
TA 62	44 / 41 / 33	50	150		113.7			252	445	485	465					505				
TA 63	55 / 50 / 37	64	192		149.7			252	515	555	535					575				
TA 63F	82 / 75 / 55	90	192		149.7			257	690	730	690					730				

ENCODER SYSTEMS

Resolver resolution 12 bit/revolution
 BISS Singleturn - 9 bit/revolution
 Hiperface Singleturn - 17 bit/revolution

Multiturn - 12 bit/revolution – 19 bit revolution
 Multiturn - 12 bit/revolution – 17 bit revolution

Features:
 straight plug, shaft with keyway,
 PTC-Sensor, protection IP 54

Options:
 permanent magnet brake, right angle plug,
 KTY-Sensor Protection Ip65

Prepared for the operation with

COMBIVERT F5 **COMBIVERT S6** **COMBIVERT F6** **COMBIVERT H6**

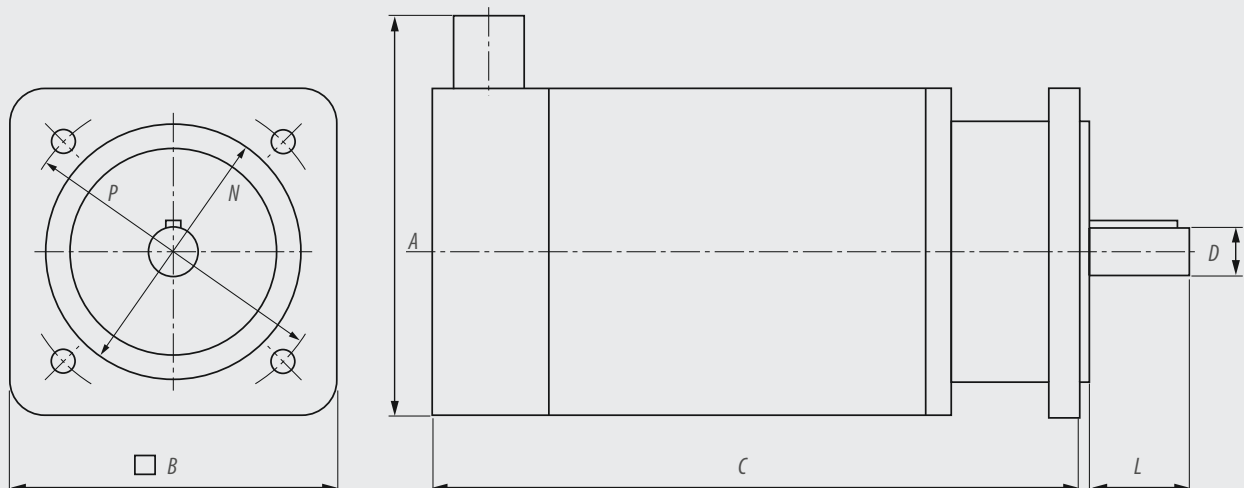

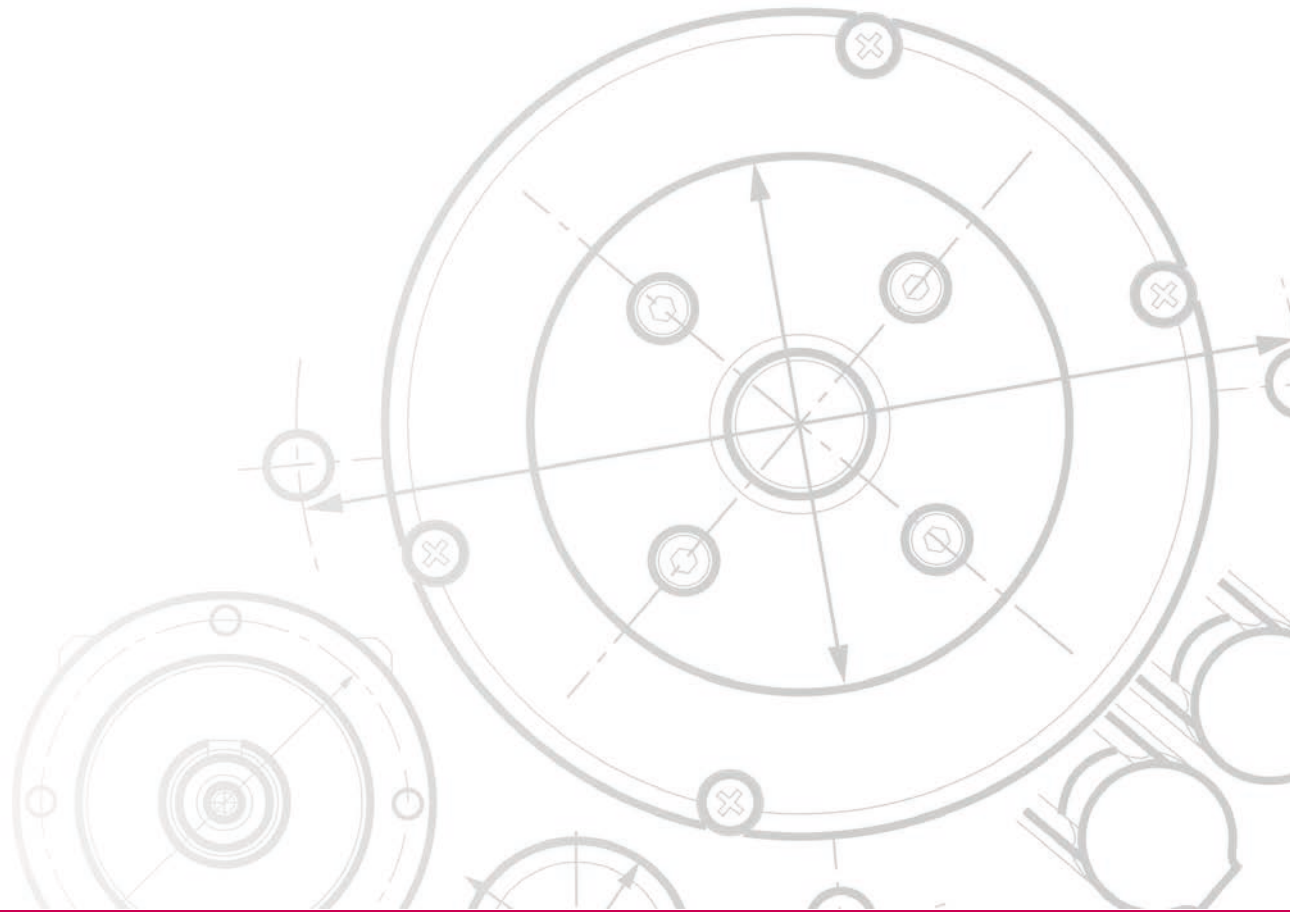

Automation with Drive