

Lumiglas luminaire Lumistar ME in stainless steel

- **Sturdy, attractive stainless steel shape, protected by registered design**
- **For use with screwed sight glass fittings**
Ideal for combined sight and light glass ports, suitable for circular screwed sight glass fittings to DIN 11851 or similar, sizes DN 65 to DN 125
- **Application:**
Designed for illuminating inside visual flow indicators, pipelines, laboratory mixers, as well as the interiors of vessels, tanks, agitators, stirrers and other normally closed containers **in non explosive operating areas.**
Suitable for use in food processing industries.
- **Protection:**
When correctly fitted, dust and splash water protected, IP65 to EN 60 529/DIN VDE 0470 part 1
- **Operating conditions:**
Independent of vessel pressure/vacuum; max. permissible ambient temperature at cable gland: 80°C
- **Electrical data:**
Operating voltage: 24 V (12 V available as alternative)
Lamp: 2-pin halogen lamp, 20 W or 50 W, depending on model
- **Lamp holder:** 2-pin socket
- **Transformer:** Available as a special accessory
- **Integral switch:**
An integrated push button switch is standard on all luminaires.
- **Please note:**
The luminaire should not be connected to the power supply until the mechanical installation is complete.
- **Electrical connection:**
The Lumiglas Luminaire Lumistar ME in stainless steel is factory-fitted with a 3-metre cable tail which is temperature-resistant up to 90°C (Lapptherm 105). All internal wiring is complete and ready for use.
- **Installing a different/new cable:**
 - Select a connecting cable that is suitable for the operating conditions.
 - The cable diameter should be the same as the cable gland.
 - Remove the reflector.
 - Insulate the cable ends.
 - Insert the cable through the cable gland into the lamp chamber and wire to the terminals or push-on blades (leading the protective earth along the housing wall).
 - Tighten the cable gland.
 - Re-install the reflector.
 - It is easier to carry out the connection process if the filament lamp is removed first. The user then has more space, and damage to the lamp is avoided.
- **Mechanical installation:**
 - Loosen the slotted cover nut of the screwed sight glass fitting.
 - Lead the slotted cover nut over the connecting cable and lamp housing.

CE

also available
in LED-technology

3755.192 b
Data Sheet 06.02.02



Lumiglas luminaire Lumistar ME in stainless steel

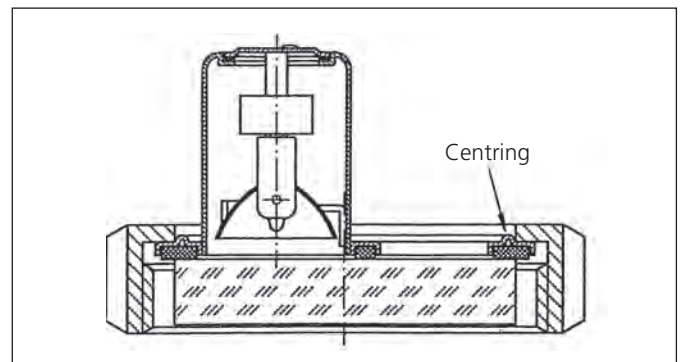

- Ensure that the sight glass is correctly positioned in the fitting.
- Focus the luminaire, making sure to align the centring feature on the slotted cover nut (see drawing).
- Screw the slotted cover nut tight against the welding adapter with the luminaire fitted.

• Changing the lamp:

- Caution! Before opening the luminaire, check that it is not too hot!
- Disconnect the luminaire from the power supply.
- Tip: By loosening the cable gland slightly it is easier to work on the luminaire as the internal wiring has more space.
- Open the cover and pull it out together with the installed lamp holder and the defective filament lamp.
- Remove the defective filament lamp.
- Using a protective cloth to hold the new filament lamp, insert it carefully into the 2-pin socket and push it into place.
- Replace the cover with lamp holder and new filament lamp, check that the cables are in the correct position before screwing on the cover.
- Tighten the cable gland whenever the lamp has been replaced. Reconnect the power supply.

• Dimensions and connection data for Lumiglas luminaire Lumistar ME in stainless steel

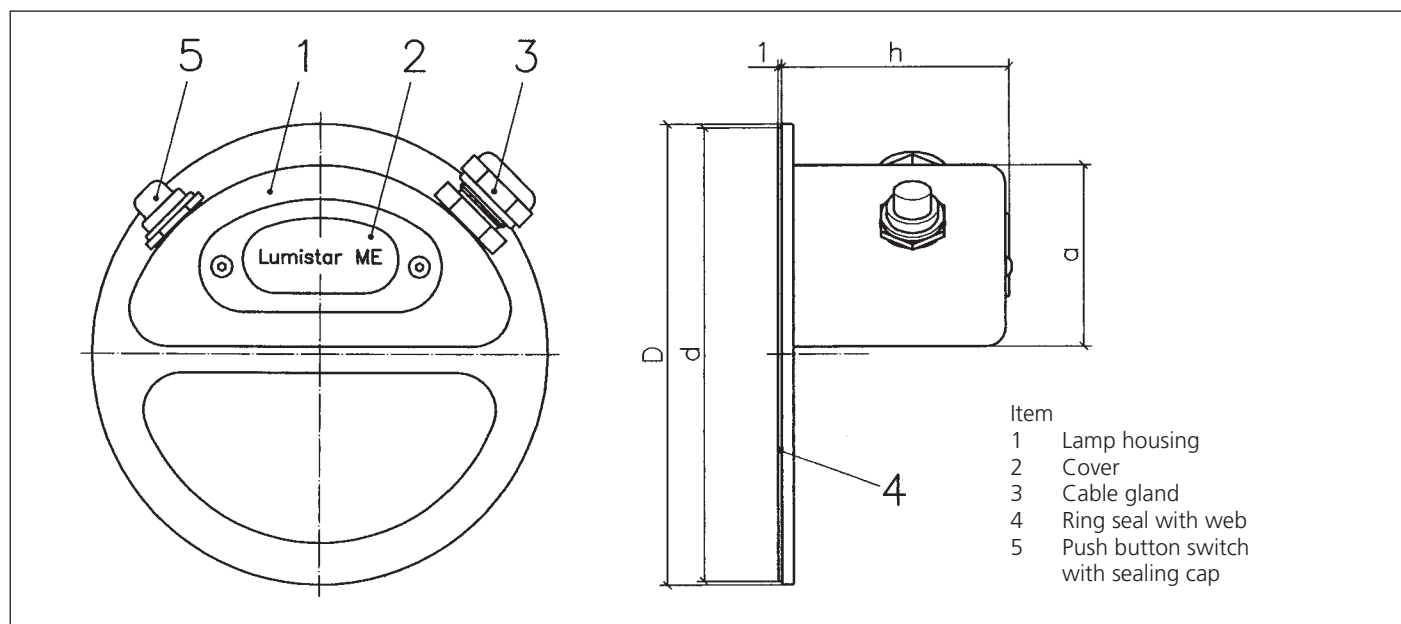

• Components, materials and assembly:

- Luminaire made of 1.4301 stainless steel
- Optimally suited for the pharmaceutical, food processing industries, etc.
- Lamp cover (2) is fitted with resilient flat seal and screws into the luminaire housing (1) (terminal box)
- Push button switch (5) with separate sealing cap is a standard feature for short-term operation
- Electrical cable connection through cable gland (3) to internal terminals 2.5 mm²
- Supply cable: 3 m cable tail is works-fitted and internally wired ready for use, Lapptherm 105 up to 90°C

size		1	2	3	4
Lumiglas luminaire	type	ME 65	ME 80	ME 100	ME 125
compatible with screwed sight glass fittings to DIN 11851 or similar	DN	65	80	100	125
operating voltage	V	24	24	24	24
wattage	W	20	20	50	50
dimensions	D	89	102	122	152
	d	86	99	119	149
	a	35	35	48	48
	h	45	45	60	60
weight approx. (with connecting cable, without packaging)	kg	0.320	0.340	0.440	0.460
part no.		3544.121.00	3544.122.00	3544.123.00	3544.124.00

- **Combination with Lumiglas sight glass wiper SW I:** The Lumiglas luminaire Lumistar ME 125 in stainless steel can be combined with the Lumiglas sight glass wiper SW I.

- **Ordering data:** e. g. Lumiglas luminaire stainless steel Lumistar ME 100 / 24 V-50 W, part no. 3544.123.00

• Important, please note when ordering!

If the Lumiglas luminaire Lumistar ME in stainless steel is to be mounted on an already installed screw-type sight glass fitting, a specially adapted slotted cover nut should be ordered at the same time, or any existing one must be mechanically adapted. If necessary, please consult your Lumiglas sales contact! (See also hole diameter 'd' acc. to DIN 11851).

All dimensions in mm unless stated otherwise. Subject to change without prior notice.