

CM-95-250



Permanent-magnet machine for direct drive of applications with highest speed demands.

- Special mechanical rotor construction for highest stresses
- Stator winding and core configuration for optimal efficiency despite highest rotational speeds
- Low heat generation in stator and rotor
- High-speed ball bearings with permanent lubrication
- Ideal in combination with converter CC-230-3500
- Customized adaptations available



Specifications motor

Pole-pair number	1
Rated speed	250,000 rpm
Rated power	2,500 W
Rated torque	95 mNm
Weight	1 kg
Temperature measurement	Pt100
Axial moment of inertia (rotor)	$9.38 \cdot 10^{-7} \text{ kg m}^2$
Cable length (3 x motor phases and PT100)	2 m

Operation range

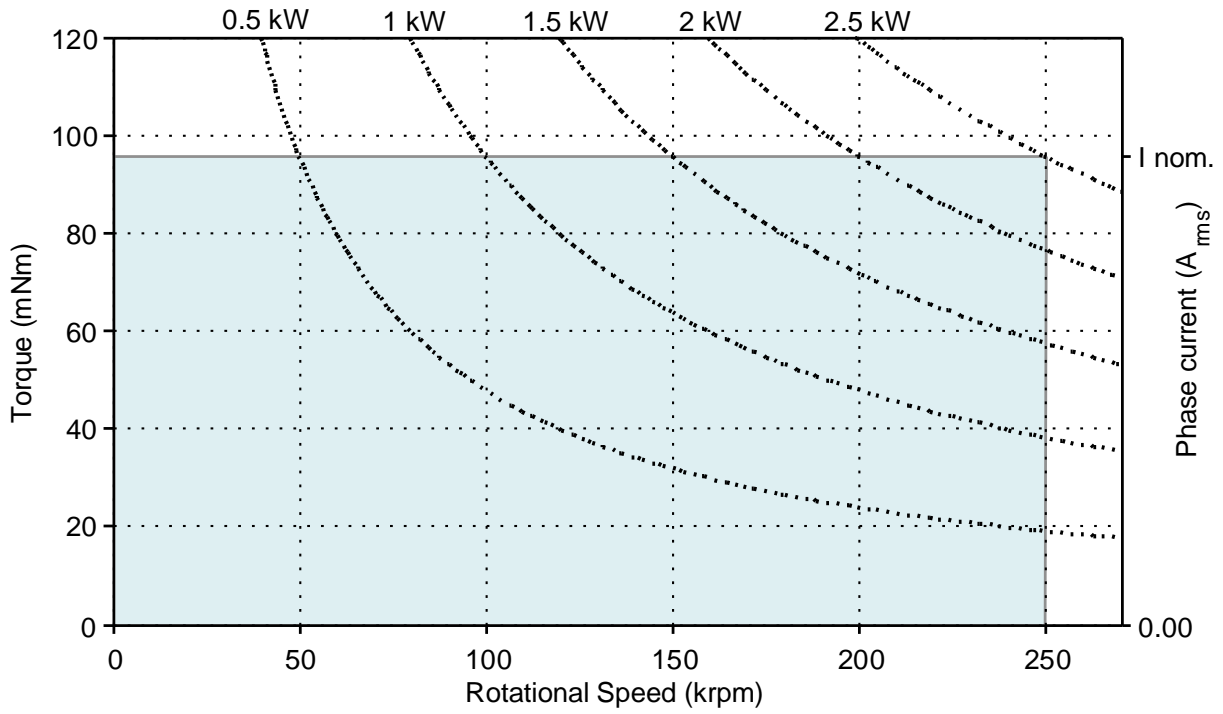

Drawing (in mm)

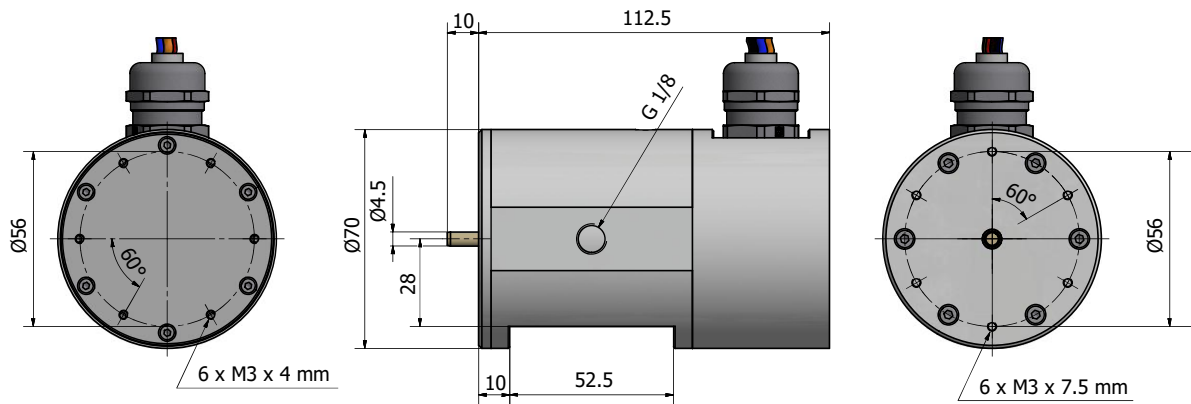

Order codes: CM-95-250.Rxxx.Bxx.Fxx.Cxx

Rotor type Rxxx	
RM00	Without boring/thread (standard)
RM03	With M3 thread (right hand)
RD03	With 3 mm boring
RC99	Other bore diameter/threads on request

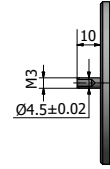

Bearing options Bxx	
B00	Standard ball bearing
B01	Vacuum ball bearing
B99	Custom ball bearings

Front flange Fxx	
F00	Standard flange, rotor dismountable only without front load attached
F01	Half-shell flanges, rotor dismountable with front load attached
F99	Custom related flange

Cooling flange Cxx	
C00	Cooling flange with radial G1/8" inlet/outlet, flexible orientation
C99	Other cooling flanges

Optional services for customized adaptations	
▪ Thermal design	▪ Rotordynamic design
▪ Balancing	▪ Mechanical design