

Series 800 Smartstat

Electronic Temperature Switch & Transmitter

Data sheet : S800T/2012

The Series 800 Smartstat is a microprocessor controlled temperature switch, transmitter and indicator, which enables several instruments to be replaced with a single device.

- RANGES FROM -40°C TO 400°C
- 24VDC SUPPLY, 4-20mA LOOP POWERED
- HIGH ACCURACY AND REPEATABILITY
- STANDARD ELECTRICAL AND I.S. CERTIFIED VERSIONS AVAILABLE
- REDUCE COSTS

There are some temperature switching applications that are very demanding due to the need for :-

1. Very high (or low) temperatures.
2. High accuracy and repeatability.
3. Very large (or small) switching differentials.

These requirements may exceed the capabilities of conventional mechanical temperature switches, the Smartstat was designed to overcome these problems.

The Smartstat is available with temperature ranges from -40°C to 400°C, providing a typical accuracy of 0.5% and repeatability of 0.1%.

Two independent single-pole, double-throw (SPDT) relays are fitted in the Smartstat, the operating points of which can be set anywhere within the range. The switching differential can be set from 0.1% to 100.0% of range without loss of accuracy.

SUBSTANTIAL COST SAVINGS

Replacing a transmitter, switches and a gauge with a single Smartstat reduces equipment costs. Additionally there are reductions in documentation, installation time/fittings/cabling, and calibration/maintenance costs.

MICROPROCESSOR CONTROL

Additional benefits of the Smartstat include -

- Pushbutton calibration of set points and transmitter range enables calibration on site without tools.
- Programmable switching delays - the switching on or off (or both) of the relays may be delayed from 0.5 seconds to 15 minutes. This is particularly useful for preventing unwanted switching due to temperature transients.
- Display of maximum and minimum temperatures recorded by the Smartstat.
- Display of transmitter output in mA.

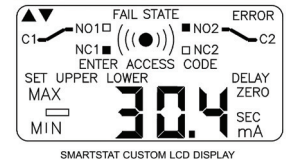

Series 800 Temperature Range Codes

Range Code	Temperature Range °C	Maximum Temperature °C	4-20 mA	
			Min. Span	Max. Span
881T	-20 to +30°C	500°C	10°C	50°C
882T	0 to 50°C	500°C	10°C	50°C
883T	-40 to +60°C	500°C	20°C	100°C
884T	-20 to +80°C	500°C	20°C	100°C
885T	0 to 100°C	500°C	20°C	100°C
886T	0 to 200°C	500°C	40°C	200°C
887T	0 to 300°C	500°C	60°C	300°C
888T	0 to 400°C	500°C	80°C	400°C

NOTES ON RANGE TABLE:

1. The RTD element used in the Smartstat can be configured to provide almost any range between -100°C and +400°C, and high temperature elements can be used up to 650°C. If the range you require is not listed above please contact Rototherm Technical Sales.
2. The minimum span setting for the 4-20mA transmission is 20% of the Smartstat range. The maximum setting is 100% of the Smartstat range.

SMARTSTAT OPERATION

The input temperature applied to the Smartstat is converted to a proportional electrical signal by the PT100 IEC751: Class A, platinum-resistance sensor. After amplification this signal inputs directly into the analogue to digital (a/d) port on the microprocessor.

The microprocessor continuously calculates the temperature from the input signal, compares this to the switch setpoints and operates the relays as required. If the temperature rises above the UPPER switch point the relay changes over from normally closed (NC) to normally open (NO), as the temperature falls below the LOWER switch point the relay changes over from NO to NC.

In addition the microprocessor updates the LCD display of the temperature and the status of the relays. The typical response time of the relays to an alarm condition is about 125mSec.

Should the 24Vdc power supply fail (or fall below 12 volts) the relays can be configured to remain in their current position or switch to the NO or NC position. This is the 'Fail State' that is indicated on the LCD.

A separate watchdog timer (WDT) continuously monitors the operation of the microprocessor. In the unlikely event that the processor 'hangs' this is detected by the WDT which re-boots the processor, restoring normal operation within 3 seconds.

Entry of the switching points, the Fail State and switching delays for each relay is carried out using the pushbuttons on the front of the Smartstat. An access code must be entered first to ensure that there are no unauthorised changes.

The temperature settings for each relay are adjustable throughout the range enabling the switching differential to be varied from just one digit, up to 100% of the range. All of the information entered is stored on an EEPROM so that it is retained when the power supply is off.

The pushbuttons on the front of the Smartstat are also used to calibrate the transmitter output. An access code must be entered first to ensure that there are no unauthorised changes. The 'start of range' and 'end of range' can be input and 4-20 mA or 20-4 mA selected. If the transmitter output is not required it can be disabled, resulting in a constant supply current of 3.5mA to the Smartstat.

The maximum and minimum temperatures applied to the Smartstat can be displayed by pressing the MAX or MIN pushbuttons. These values can be reset to the current temperature by holding down the appropriate pushbutton for 15 seconds.

The relays are optional on the Smartstat and can be obtained at a later date and easily fitted by the customer.

Series 800 Smartstat Specifications & Coding

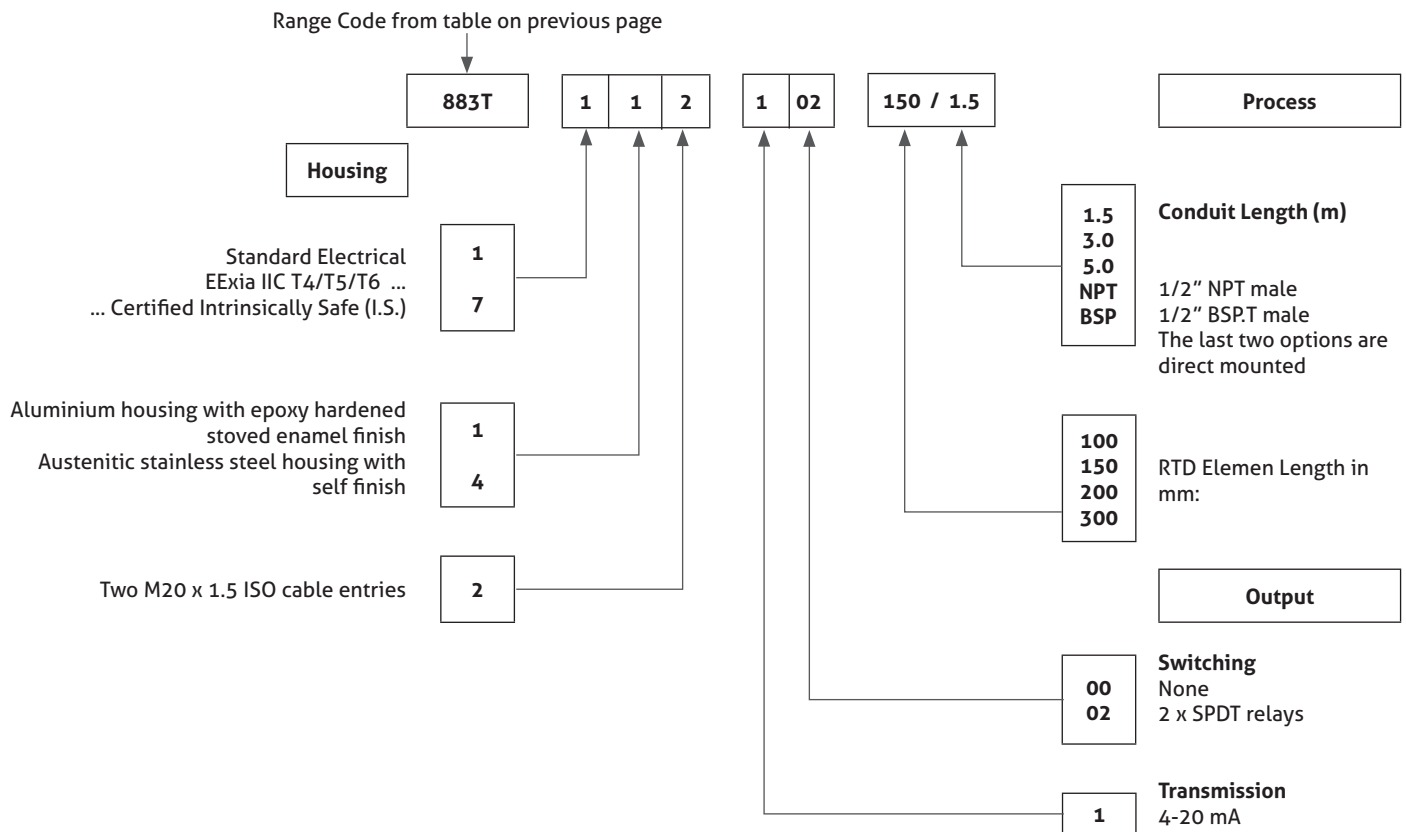

NOTES:

1. Dust and weatherproof ratings are IP65 to BS EN 60529 (IEC60529).
2. Almost any probe and conduit lengths can be provided. If the option you require is not listed above please contact Rototherm Technical Sales. Please note that the minimum probe length that can be provided is 50mm and the maximum conduit length for an I.S. (Intrinsically Safe) Smartstat is 10 metres.
3. All probes are 6mm diameter.
4. The probe and conduit are manufactured in stainless steel.
5. Smartstat temperature switches use a four-wire, class 'A' RTD element that provides an accuracy of:
 - 0.3°C at 0°C
 - 0.8°C at 100°C
 - 1.3°C at 200°C
 - 2.3°C at 400°C

THERMOWELLS

Rototherm can supply 316 stainless steel screwed bar stock thermowells suitable for the 6mm probes fitted on Smartstat temperature switches.

They are available with different thread options including 1/2" NPT male and 1/2" BSPT male, and different insertion lengths to suit the process requirements.

Thermowells are also available for the direct-mounted Smartstat temperature switch. These have a 3/4" NPT male connection for process mounting and a 1/2" NPT female connection for the Smartstat.

Series 800 Smartstat Technical Specifications

STANDARD ELECTRICAL SMARTSTATS:

Power Supply

24Vdc @ 3.5mA without 4 - 20mA transmission.
24Vdc @ 22mA with 4 - 20mA transmission.
Maximum supply voltage 30Vdc.

Switching

Relays have multi-layered contacts making them suitable for switching from 100mVdc 100µA to 30Vdc 3A or 250Vac 4A.
Minimum switching life 10⁵ operations.

I.S. CERTIFIED SMARTSTATS:

EEx ia IIC T4/T5/T6 EN50 014, EN50 020 & EN50 284.
T4 = 80°C, T5 = 55°C, T6 = 40°C.
Certificate No: Baseefa 03ATEX0504X.

Power Supply

24Vdc @ 3.5mA without 4 - 20mA transmission.
24Vdc @ 22mA with 4 - 20mA transmission.
24Vdc supply via any 28V 300ohm I.S. source certified by Baseefa or any EEC approved certification body to EEx ia IIC.
For Smartstat supply C=0, L=0.
Suitable barriers include MTL702+, MTL3041, MTL5041 etc.

Switching

Each relay must be connected to a separate (or the same) I.S. source certified by Baseefa or any EEC approved certification body to EEx ia IIC whose output does not exceed 28Vdc.

U_{max} IN = 28Vdc, I_{max} IN=3.33A. For relay outputs C=0, L=0.
Suitable barriers include MTL707+, MTL2210B, MTL5016 etc.

ALL SMARTSTATS:

Ambient temperature range: -20°C to +85°C (I.S. may be lower).

Accuracy

Linearity Error: +/- 0.2% typical.
Temperature hysteresis: +/- 0.1% max.

CE

This product satisfies the requirements of the Electromagnetic Compatibility Directive 89/336/EEC and amendments by compliance with standards EN50081-2 : 1993 and EN50082-2:1995. This product also complies with standard EN60947-5-1:1997 in addition to the standards listed for hazardous area certification.

TYPICAL 800 SERIES DIMENSIONED OUTLINES

